

NARROW SPOT IR THERMOMETER

800002

Instruction Manual

SPER
SCIENTIFIC

Environmental Measurement Instruments

TABLE OF CONTENTS

Features	2
Front Panel Description	3
Measurement Procedures	4
How to Hold the Probe when Measuring	5
Emissivity.....	6
Calculating & Adjusting Emissivity	7
Factors Affecting Measurement.....	8
Battery Replacement.....	10
Specifications	11
Warranty	12

FEATURES

- Very useful for measuring the surface temperature of small and narrow spot targets, such as IC, transistors, coils, and transformers
- 0.1°C and F minimum resolution
- Emissivity adjustment from 0.10 to 0.95
- Removable probe, easy operation, and remote measurement
- Large LCD display
- Minimum and maximum recordings with recall
- Data hold function

FRONT PANEL DESCRIPTION

1. Display
2. Data **HOLD** Button
3. °C/°F Scale Selection Button
4. Memory **RECORD** Button
5. Memory **RECALL** Button
6. **POWER** Switch
7. **1° / 0.1°** Resolution Selection Switch
8. Battery Compartment Cover
9. IR Probe Socket
10. Emissivity Adjustment VR
11. IR Probe Main Body
12. IR Probe Sensing Head
13. Meter Input Plug

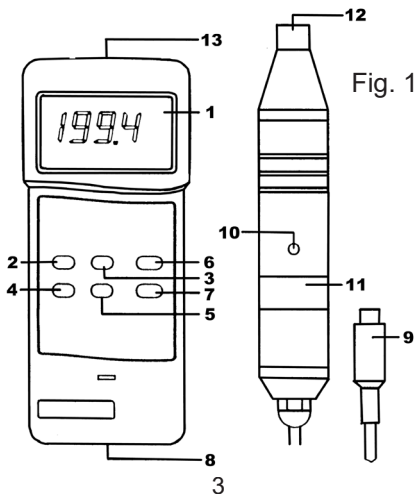

MEASUREMENT PROCEDURE

1. Plug the IR probe plug (Fig.1-9) into the meter input socket (Fig.1-13).
2. Turn meter on using the **POWER** switch (Fig.1-6).
3. Choose scale using the °C/°F button(Fig.1-3). The chosen scale will appear in the lower right of the display.
4. Select the resolution by moving the 1°/0.1° switch (Fig.1-7). Use “1°” for general use.
5. While holding the IR probe main body (Fig.1-11), point the tip of the probe (Fig.1-12) at the object being measured. The meter will display the surface temperature.
 - The ideal distance between the probe and the surface being measured is 10 mm (3/8 inch)
 - The size of the object should be at least 2.5 mm (3/32 inch)

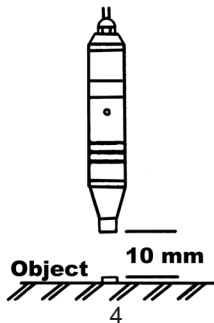

6. Data Hold: During measurement, the “HOLD” button (Fig.1-2) will hold the measure value and the LCD will show “D.H.” in the upper left of display. Pressing the “HOLD” a second time will release the data hold function.

7. Data Record: The recording function displays the minimum and maximum readings. To start, press the “RECORD” button (Fig.1-4). “REC” will show in the lower left of the display. With “REC” on:

- Press “RECALL”. “MAX” will show in the display with the maximum temperature value.
- Press “RECALL” again to change display to show the minimum value. “MIN” will show in the display.
- To exit record mode, press “RECORD”. Display will revert to current reading.

HOW THE PROBE SHOULD BE HELD DURING MEASUREMENT

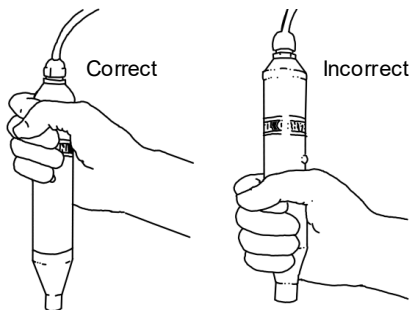

EMISSIVITY

All objects emit invisible energy. The amount of energy is proportional to the object's temperature and its ability to emit energy. This ability to emit energy is called emissivity and based upon the composition of the object and the qualities of the surface. Emissivity values range from 0.10 for a very reflective object to 1.00 for a flat black surface.

The probe of the IR Thermometer senses energy and calculates the temperature based on the amount of IR energy it receives and a factory set emissivity value of 0.95, which will cover 90% of the typical applications. However, if the emissivity value of the measured material is not 0.95, the emissivity value should be adjusted.

CALCULATING AND ADJUSTING EMISSIVITY

To match the correct emissivity with the specific value of the object is important in order to obtain exact temperature. When the emissivity of the object is unknown, calculating the exact value can be difficult and require the use of other devices. However, there are several easy ways of calculating the emissivity value. For example:

Use a digital thermometer and a surface probe to measure the object's temperature as close as possible. Then, while measuring the object with the IR probe, adjust the "Emissivity Adjust VR" (Fig.1-10) with a small flat head screwdriver until the readings match.

- Turning the VR to the left (counter-clockwise) will adjust the emissivity to 0.10 to 0.94.
- Turn the VR all the way to the right to reset the probe to 0.95.

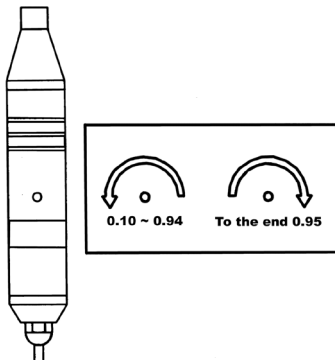

FACTORS AFFECTING MEASUREMENT

1. Measurement Field/Distance:
 - The ideal distance between the probe and the surface being measured is 10 mm (3/8 inch)
 - The size of the object should be at least 2.5 mm (3/32 inch)
2. Positioning: For the most accurate reading, the probe should be held as perpendicular to the object as possible. This is especially important when the difference between the ambient temperature and the object temperature are significantly different.
3. Disturbance: Objects having low emissivity or objects having a low temperature yet high emissivity emit little infrared energy. Measurement of these objects is adversely effected by powerful infrared energy radiated from nearby objects having high emissivity or high temperature. For example, when measuring objects in sunlight, erratic measurements are caused as strong radiated energy from the sun is reflected on the surface of the object which enters the sensor.

4. Incorrect Emissivity: This can cause incorrect readings. If you believe that this is happening, adjust the emissivity (refer to page 6).
5. Coating: If the object surface is covered with frost, ice, or other material, clean it to expose the true surface.
6. Reflectance: If the surface is highly reflective, apply masking tape or apply flat black paint, or another means to flatten reflectivity.

BATTERY REPLACEMENT

“LBT” will appear in the upper left of the display when the battery outputs less than 6.5 to 7.5 v. You should replace the battery as soon as possible. However, measurements made for several hours will still be within specs after the low battery indicator appears. As the battery depletes, the readings will become inaccurate.

1. To replace the battery, remove the “Battery Cover” (Fig.1-8) on the rear of the instrument by careful prying with a flat head screw driver.
2. Remove the battery and replace it with a new 9v battery.
3. Replace the cover.

SPECIFICATIONS

Accuracy	10°C to 150°C-2% of reading or 2°C, whichever is greater*
Resolution	1°C 10 to 150°C
	1°F 50 to 302°F
	0.1°C 10.0 to 110.0°C
	0.1°F 50.0 to 230.0°F
Emissivity Setting	0.10 to 0.95 with a factory preset of 0.95
Temperature Sensor	Thermocouple pie
Measurement Wavelength Region	6 to 12 micrometers
Distance Factor	D/S: Approx. 10:1 D=Distance, S=Size of spot
Sampling Time	Approx. 1 second
Operating Temperature	0 to 50°C (32 to 122°F)
Operating Humidity	Less than 80% RH
Power Supply	9v Battery (included)
Power Current	Approx. DC 4.8 mA
Dimension of Meter	180 x 72 x 32 mm (7.1 x 2.8 x 1.3 inch)
Dimension of Probe	31.5 mm diameter cylinder x 170 mm (1.25" dia. X 6.75")
Weight	385g/13.5 oz.
Display	13 mm (0.5 inch) digit LCD

WARRANTY

Sper Scientific warrants this product against defects in materials and workmanship for a period of **five (5) years** from the date of purchase, and agrees to repair or replace any defective unit without charge. If your model has since been discontinued, an equivalent Sper Scientific product will be substituted if available. This warranty does not cover probes, batteries, battery leakage, or damage resulting from accident, tampering, misuse, or abuse of the product. Opening the meter to expose its electronics will void the warranty. To obtain warranty service, ship the unit postage prepaid to:

SPER SCIENTIFIC LTD.
8281 E. Evans Rd., Suite 103
Scottsdale, AZ 85260

The defective unit must be accompanied by a description of the problem and your return address. Register your product online at www.sperwarranty.com within 10 days of purchase.