

Drägermedical

A Dräger and Siemens Company

Operator's Instruction Manual

Part Number: 4117102-005

Rev: —

Fabius GS Software Version 1.3n

Date: 12 September 2003

© 2003 Draeger Medical, Inc.

Fabius GS[®]

Warning: For a full understanding of the performance of this anesthesia machine, the user should carefully read this manual before operating.

Chapter 1. Introduction

Contents	1
Overview	3
Operator's Responsibility	3
Intended Use	4
Safety Features	4
Copyright, Trademark, and Limitation of Liability	4
Symbol Definition	5
Abbreviations	8
General Warnings and Cautions	9

Chapter 2. Configurations and Components

Contents	11
Typical Fabius GS Configuration	13
Components	13

Chapter 3. Operating Concept

Contents	15
Overview	17
Standard Function Controls	17
Cross-Functional Controls and Displays	18
Monitoring	20
Ventilation	24
Fresh Gas Control	33
Fresh Gas Flow Monitoring Resolutions	34
APL Valve	35

Chapter 4. Preparation

Contents	37
Activating the Battery	39
Gas Supply	39
Medical Gas Pipeline Supply of O ₂ , N ₂ O, and AIR	39
Cylinders with Pin-index Mounting	40
Electrical Supply	41
Attaching Manual (Ambu) Ventilation Bag	41
Preparing the Ventilator	42
Ventilator Safety Features	42
Attaching the CO ₂ Absorber onto the Compact Breathing System	43
Attaching the Inspiratory Valve	43
Attaching the Expiratory Valve	43
Attaching the Adjustable Pressure Limiting (APL) Valve	44
Inserting the Flow Sensor	44
Attaching the Waste Gas Outlet Port	44
Connecting the Compact Breathing System	45
Connecting the Breathing Hoses	46
Inserting A New O ₂ Sensor Capsule	46
Connecting the O ₂ Sensor	47
Connecting the Pressure Sensor	47
Connecting the Breathing Pressure Gauge	48
Connecting the APL Bypass and Peep/PMAX Hoses	48

Contents

Connecting the Flow Sensor	49
Installing Anesthetic Gas Scavenging Hose to the Compact Breathing System	49
Scavenger System for Fabius GS	50
Additional Equipment	50
Daily and Preuse Checkout Form	50

Chapter 5. Operation and Shut-down

Contents	51
Operation	53
Preparation for Transport or Storage	60

Chapter 6. Monitoring

Contents	63
Overview	65
Alarms	65
Oxygen Monitoring	66
Respiratory Volume Monitoring	72
Breathing Pressure Monitoring	77

Chapter 7. Setup Window (Used During Operation)

Contents	83
Overview	85
Setup Window Access	85
Auto Set	86
Calibrate O2 Sensor	86
Activate Des Comp	87
Access Alarm Log	88
Access Alarm Volume	88
Window Deactivation	88

Chapter 8. Standby Mode Functions

Contents	89
Overview	91
Standby Screen	91
Standby Setup Screen	95

Chapter 9. Routine Maintenance and Cleaning

Contents	105
Routine Maintenance	107
Disassembling	107
Disinfecting/Cleaning/Autoclaving	109
Maintenance Intervals	111
Checking Readiness for Operation	111

Chapter 10. Troubleshooting

Contents	113
----------------	-----

Chapter 11. Components

Contents	117
Front View	119
Compact Breathing System (Top View)	120
Rear View (3-Gas Supply Connections)	121

Chapter 12. Technical Data

Contents	123
Technical Data	125
Diagrams	132

Appendix. Daily and Preuse Checkout Form

Introduction

Contents

Overview	3
Recommendations	3
Not for Use in Areas of Explosion Hazard	3
Safe Connection with Other Electrical Equipment	3
Operator’s Responsibility	3
Intended Use	4
Safety Features	4
Copyright, Trademark, and Limitation of Liability	4
Copyright	4
Trademark Notices	4
Limitation of Liability	4
Symbol Definition	5
Abbreviations	8
General Warnings and Cautions	9

Overview

Caution: For your safety and that of your patients, strictly follow this instruction manual.

Any use of the Fabius GS® requires full understanding and strict observation of these instructions. The unit is only to be used for purposes specified here.

Recommendations

Because of the sophisticated nature of Draeger Medical anesthesia equipment and its critical importance in the operating room setting, it is highly recommended that only appropriately trained and experienced professionals, using authentic Draeger Medical spare parts, be permitted to service and maintain this equipment. Please contact DrägerService at (800) 543-5047 or (215) 721-5402 for service of this equipment.

Draeger Medical also recommends that its anesthesia equipment be serviced at six-month intervals. Periodic Manufacturer's Certification Agreements are available for equipment manufactured by Draeger Medical. For further information concerning these agreements, contact DrägerService at (800) 543-5047 or (215) 721-5402.

Not for Use in Areas of Explosion Hazard

The Fabius GS is neither approved nor certified for use in areas where combustible or explosive gas mixtures are likely to occur. To avoid explosion hazards, flammable anaesthetic agents such as ether and cyclopropane or other flammable substances must not be used in this machine. Only anaesthetic agents that comply with the requirements on non-flammable anaesthetic agents in the IEC Standard, Particular requirements for the safety of anaesthetic machine, are suitable for use in this machine.

Safe Connection with Other Electrical Equipment

Electrical connections to equipment which are not listed in these Instructions for Use should only be made following consultations with the respective manufacturers or an expert and shall be in compliance with national medical device regulations.

Operator's Responsibility

The equipment design, the accompanying literature, and the labeling on the equipment take into consideration that the purchase and use of the equipment are restricted to trained professionals, and that certain inherent characteristics of the equipment

are known to the trained operator. Instructions, warnings, and caution statements are limited, therefore, to the specifics of the Draeger Medical, Inc. design. This publication excludes references to hazards which are obvious to a medical professional, to the consequences of product misuse, and to potentially adverse effects in patients with abnormal conditions. Product modification or misuse can be dangerous. Draeger Medical, Inc. disclaims all liability for the consequences of product alterations or modifications, as well as for the consequences which might result from the combination of Draeger Medical, Inc. products with products supplied by other manufacturers if such a combination is not endorsed by Draeger Medical, Inc.

The operator of the anesthesia system must recognize that the means of monitoring and discovering hazardous conditions are specific to the composition of the system and the various components of the system. It is the operator, and not the various manufacturers or suppliers of components, who has control over the final composition and arrangement of the anesthesia system used in the operating room. Therefore, the responsibility for choosing the appropriate safety monitoring devices rests with the operator and user of the equipment.

The Fabius GS is equipped to monitor breathing circuit pressure, exhaled volume and inspired oxygen, and to sound an alarm when any of these parameters violates a preset limit. The Fabius GS should not be used if any of these monitors are not functioning properly. Draeger Medical, Inc. also recommends that the Fabius GS only be used to deliver anesthesia and/or mechanical ventilation in accordance with the guidelines for patient monitoring published by the American Society of Anesthesiologists. In addition to volume, pressure, and oxygen monitoring, these guidelines require the use of a capnometer to monitor inspired and expired carbon dioxide as well as other patient monitors including continuous electrocardiography, pulse oximetry, and arterial blood pressure monitoring. Anesthetic agent monitoring and temperature monitoring are also strongly recommended. The responsibility for the selection of the best level of patient monitoring belongs solely to the equipment operator. To this extent, the manufacturer, Draeger Medical, Inc., disclaims responsibility for the adequacy of the monitoring package selected for use with the anesthesia system. However, Draeger Medical, Inc. is available for consultation to discuss monitoring options for different applications.

Restriction

Caution: Federal law and regulations in the United States restrict this device to sale by, or on the order of, a physician.

Intended Use

Fabius GS is an inhalation anesthesia machine for use in operating, induction and recovery rooms.

It may be used with O₂, N₂O, and AIR supplied by a medical gas pipeline system or by externally mounted gas cylinders.

Fabius GS is equipped with a compact breathing system, providing fresh gas decoupling, PEEP, and pressure limitation.

The following ventilation options are available:

- Volume Controlled Ventilation
- Pressure Controlled Ventilation
- Manual Ventilation
- Spontaneous Breathing

Fabius GS is equipped with an electrically driven and electronically controlled ventilator and monitors for airway pressure (P), volume (V), and inspiratory oxygen concentration (FiO₂).

As per EN740 (Anesthetic Workstations and their Modules- Particular Requirements), additional monitoring of the concentrations of CO₂ and anesthetic agent is required when the machine is in use.

Do not use readily flammable anesthetic agents such as ether, cyclopropane, etc.

Safety Features

- Monitoring of P, V, FiO₂
- O₂ SUPPLY LOW alarm
- Integrated S-ORC = Sensitive Oxygen Ratio Controller (control device to ensure minimum O₂ concentration of 23 Vol.%).

Per EN740, burns may occur if antistatic or electrically conductive ventilation tubes are used in combination with high-frequency electrical surgery equipment. Therefore, per EN740, these types of breathing tubes are not recommended.

Caution: Do not use Fabius GS in the environment of NMR tomography equipment. Malfunctions may result, thereby endangering the patient.

Caution: Do not use mobile phones within a distance of 10 meters from the machine. Mobile phones can cause malfunctions in electrical medical equipment, thereby endangering the patient and the operator.

Copyright, Trademark, and Limitation of Liability

Copyright

Copyright 2002 by Draeger Medical, Inc. All rights reserved. No part of this publication may be reproduced, transmitted, transcribed, or stored in a retrieval system in any form or by any means, electronic or mechanical, including photocopying and recording, without written permission of Draeger Medical, Inc. The exceptions to this are [“Recommendations for Typical Cleaning and Disinfection After Use” on page 110](#) and [“Daily and Preuse Checkout Form” in Appendix A](#).

Trademark Notices

DrägerService, Fabius GS, and Vitalink are registered trademarks of Draeger Medical, Inc. Fabius and Vapor are registered trademarks of Dräger. All other products or name brands are trademarks of their respective owners.

Limitation of Liability

Draeger Medical, Inc.'s liability, whether arising from or related to the manufacture and sale of the products, their installation, demonstration, sales representation, use, performance, or otherwise, including any liability based upon Draeger Medical, Inc.'s product warranty, is subject to and limited to the exclusive terms of Draeger Medical, Inc.'s limited warranty, whether based upon breach of warranty or any other cause of action whatsoever, regardless of any fault attributable to Draeger Medical, Inc. and regardless of the form of action (including, without limitation, breach of warranty, negligence, strict liability, or otherwise).

Draeger Medical, Inc. shall in no event be liable for any special, incidental, or consequential damages (including loss of profits) whether or not foreseeable and even if Draeger Medical, Inc. has been advised of the possibility of such loss or damage. Draeger Medical, Inc. disclaims any liability arising from a combination of its product with products from another manufacturer if the combination has not been endorsed by Draeger Medical, Inc.. Buyer understands

that the remedies noted in Draeger Medical Inc.'s limited warranty are its sole and exclusive remedies. Furthermore, buyer acknowledges that the consideration for the products, equipment, and parts sold reflects the allocation of risk and the limitations of liability referenced herein.

Symbol Definition

The following symbols appear on the labels on the back of the Fabius GS and are defined below.

Caution: Refer to accompanying documents before operating equipment.



Caution: Risk of electric shock, do not remove cover. Refer servicing to a DrägerService representative.

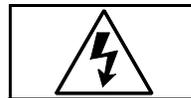

Degree of protection against electric shock: Type B.



Registration Mark



Year Manufactured



The following symbols appear on the shipping container of the Fabius GS.

This end up.

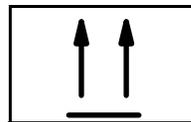

Handle with care.

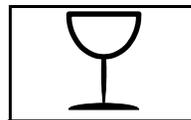

Keep dry.



Minimum and maximum storage temperatures.

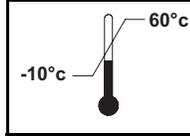

The following symbols are used on other locations of the Fabius GS to provide quick and easy recognition of product functions.

Oxygen Concentration Sensor Port



Breathing Pressure Sensor Port



Breathing Volume Sensor Port



Ventilator Port

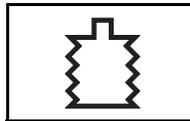

Pipeline, Gauge, Pipeline Inlet

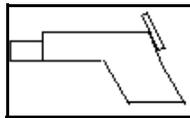

Breathing Bag

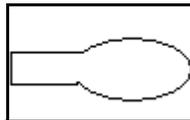

Flowmeter Level Indicator

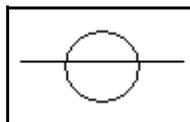

Indicates Direction

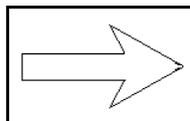

Symbol Definition

Chapter 1 - Introduction

Total Power Applied

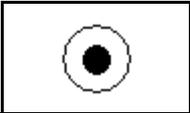

Partial Power Applied

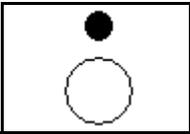

Cylinder Gauge, Remote Cylinder Inlet

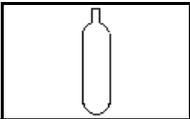

Do Not Oil



The following symbols are used on the Fabius GS monitoring user interface.

Table Top Light

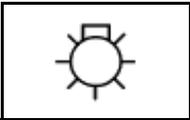

Upper and Lower Alarm Limits

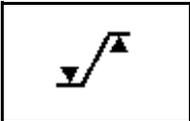

Return to Home Screen



Suppress Alarm Tone for Two Minutes



Standby Mode



Available Operating Capacity of UPS

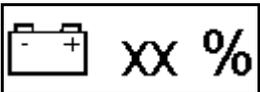

Close Menu, Back to Previous Menu

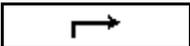

Part Number: 4117102-005 Rev: —

Upper Alarm Limit	
Lower Alarm Limit	
Mains Applied/Mains Power	
Alarm Off	
Setup Screen	

Abbreviations

Abbreviation	Meaning
FLOW	Expiratory flow
FiO ₂	Inspiratory O ₂ concentration
MAN	Manual ventilation
MEAN	Mean (airway) pressure
N ₂ O	Nitrous Oxide
O ₂	Oxygen
PAW	Airway pressure
PEAK	Peak (airway) pressure
PEEP	Positive end-expiratory pressure
PLAT	Plateau airway pressure
Pmax	Maximum (airway) pressure setting
SPONT	Spontaneous breathing
TI : TE	Ratio of inspiratory to expiratory time
Tip : Ti	Ratio of inspiratory pause time to inspiratory time
UPS	Uninterruptible power supply
VAC	Vacuum (e.g., for secretion aspiration)
VT	Tidal volume

General Warnings and Cautions

The following list of warnings and cautions apply to general operation and maintenance of the Fabius GS. Warnings and cautions about installing and operating specific parts appear with those topics.

- Warning statements give important information that, if ignored, could lead directly to a patient's or operator's injury.
- Caution statements give important information that, if ignored, could lead directly to equipment damage and, indirectly, to a patient's injury.

Warning: Any person involved with the setup, operation, or maintenance of the Fabius GS anesthesia system must be thoroughly familiar with this instruction manual.

Warning: This anesthesia system will not respond automatically to certain changes in patient condition, operator error, or failure of components. The system is designed to be operated under the constant surveillance and control of a qualified operator.

Warning: No third-party components shall be attached to the anesthesia machine, ventilator, or breathing system (except for certain approved exceptions). For more information, contact your local Authorized Service Organization or DrägerService at:
 DrägerService
 Draeger Medical, Inc.
 3122 Commerce Drive
 Telford, PA 18969
 Tel: (215) 721-5402
 (800) 543-5047
 Fax: (215) 721-5784

Warning: Each institution and user has a duty to independently assess, based on its, his, or her unique circumstances, what components to include in an anesthesia system. However, Draeger Medical, in the interest of patient safety, strongly recommends the use of an oxygen analyzer, pressure monitor, volume monitor, and end-tidal CO2 monitor in the breathing circuit at all times.

Warning: When moving the anesthesia machine, remove all monitors and equipment from the top shelf and use only the machine handles or push/pull bars. The anesthesia machine should only be moved by people who are physically capable of handling its weight. Draeger Medical recommends that two people move the anesthesia machine to aid in maneuverability. Exercise special care so that the machine does not tip when moving up or down inclines, around corners, and across thresholds (for example, in door frames and elevators). Do not attempt to pull the machine over any hoses, cords, or other obstacles on the floor.

Warning: Apply the caster brakes when the anesthesia machine is in use.

Caution: Although the Fabius GS is designed to minimize the effects of ambient radio-frequency interference, machine functions may be adversely affected by the operation of electrosurgical equipment or short wave or microwave diathermy equipment in the vicinity.

Caution: Communications with external equipment may be temporarily affected by electromagnetic interference due to the use of electrosurgical equipment.

Caution: Do not place more than 40 pounds on top of the Fabius GS monitor housing.

Caution: Never allow the battery to completely discharge. If the battery does discharge completely, recharge immediately.

Caution: Front GCX rails have a maximum accessories weight load of 5 lb./2.3 kg, extended out at 3 in./7.6 cm from the rail, at any position on the rail.

Fabius GS Back Left Side Accessory Option

Caution: Possible Tip Over Hazard If Mounting Accessories Exceed Approved Limits.

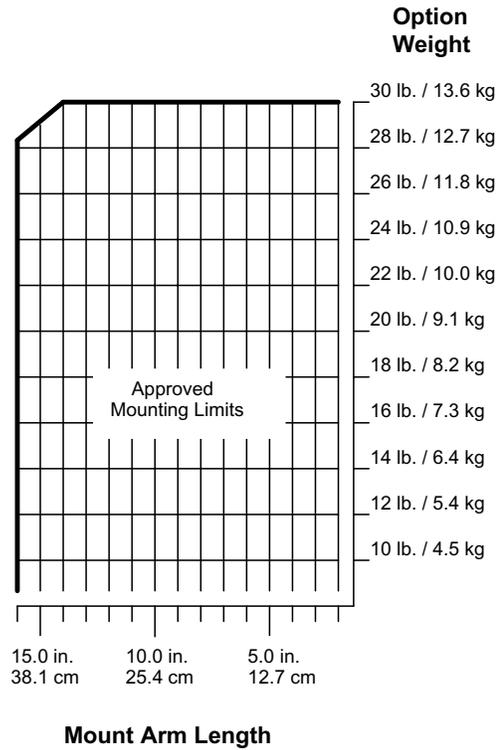

Fabius GS Back Right Side Accessory Option

Caution: Possible Tip Over Hazard If Mounting Accessories Exceed Approved Limits.

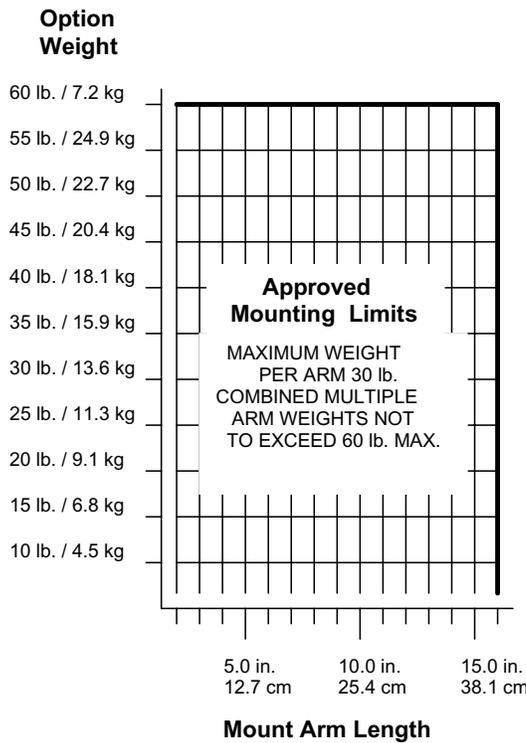

Part Number: 4117102-005 Rev: —

Configurations and Components

Contents

Typical Fabius GS Configuration	13
Components	13
Vaporizers (Optional)	13
Dräger Vapor [®] Interlock System (Optional)	13
Selectatec ^{™*} (Optional)	14

Typical Fabius GS Configuration

The Fabius GS Inhalation Anesthesia Machine is a modular system consisting of a basic gas-delivery module with a variety of components and configuration designs to meet the requirements of various anesthesia delivery applications.

- 2-gas version (O₂ and Air)
- 3-gas version (O₂, N₂O, and Air)
- pin index cylinder yokes and pressure gauges

Components

Vaporizers (Optional)

The Dräger Vapor[®] anesthetic agent vaporizers (1 in Figure 2) are used to enrich the fresh gas with a precisely metered quantity of vapor from the liquid anesthetic agent being used, i.e. Isoflurane, Halothane, Enflurane, or Sevoflurane.

When using a third-party Desflurane vaporizer:

220 V Mains	Devapor*
110 V Mains	D-Tec*

* Devapor and D-Tec are available through your local Desflurane representative.

Dräger Vapor[®] Interlock System (Optional)

The Fabius GS is configured for two vaporizers. An interlock system is used to ensure only one vaporizer can be used at a time.

Note that the selector lever (1 in Figure 3) is shown in the center position. This ensures that both vaporizers are in the locked position. Also, this is the recommended position for the selector lever when moving the Fabius GS.

Moving the selector lever away from the desired vaporizer allows that vaporizer to be utilized and the other to be locked out of use.

Figure 1. Fabius GS Anesthesia Machine



Figure 2. Dräger Vapor System

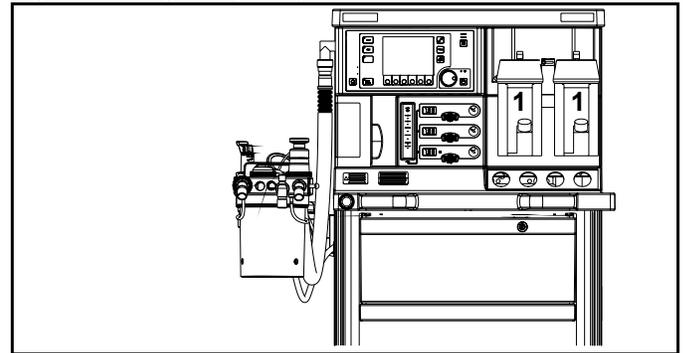
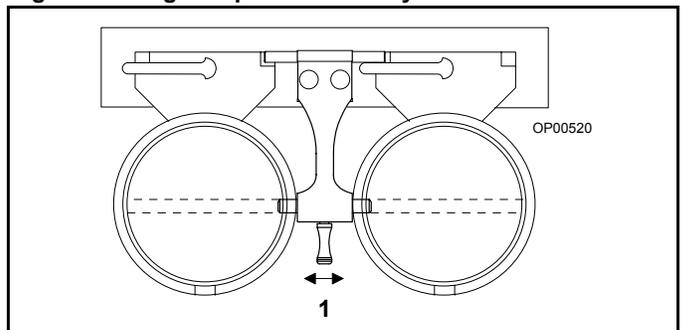

Figure 3. Dräger Vapor Interlock System



Selectatec™* (Optional)

The interlock system for the Selectatec is built into the vaporizers. When a vaporizer is selected for use, the interlocking index pins will protrude from the sides of the vaporizer thereby not allowing the neighboring vaporizer to be opened. For more specific information on the Selectatec, refer to the Selectatec Vaporizer's instruction manual.

*Selectatec™ is a registered trademark of Datex-Ohmeda.

Operating Concept

Contents

Overview	17
Standard Function Controls	17
Home Key	17
Mains Power Applied LED	17
Selecting and Confirming	17
Tabletop Light Key	17
Cross-Functional Controls and Displays	18
Key LED Indicators	18
Setup Key	18
Status Bar	19
Monitoring	20
Monitoring Controls	20
Monitoring Windows	21
Selecting/Setting Monitoring Functions	22
Ventilation	24
Ventilation Controls	24
Ventilator Compliance Compensation	24
Ventilation Screens	25
Changing Ventilation Modes	28
Selecting/Setting Ventilation Parameters	32
Fresh Gas Control	33
Fresh Gas Flow Monitoring Resolutions	34
Standard Resolution	34
High Resolution	34
APL Valve	35

Part Number: 4117102-005 Rev: —

Overview

This chapter provides an overview of the user interface, which enables you to set and view monitoring, ventilation, and status information using the respective screens, windows, keys, soft keys, and the rotary knob. See “Monitoring” on page 63 for more information.

Standard Function Controls

Home Key

The Home key (1 in Figure 4) displays the main screen (the screen in Figure 4) from anywhere in the system.

Mains Power Applied LED

The Mains Power Applied LED (2 in Figure 4), when illuminated, indicates that the machine is connected to a Mains power source.

Selecting and Confirming

The rotary knob (3 in Figure 4) is used to select and confirm functions by:

- Turning (Select)
 - Turning the rotary knob
 - moves the cursor over the system operating parameters or
 - changes the value of a parameter that has been confirmed for adjustment.

Note: This function is indicated in the examples and instructions of this manual by “select.”

- Pressing (Confirm)
 - Pressing the rotary knob either
 - confirms the system operating parameter to be adjusted or
 - confirms the change to the selected operating parameter.

Note: This function is indicated in the examples and instructions of this manual by “confirm.”

Tabletop Light Key

The Tabletop Light key (4 in Figure 4) turns on the tabletop light.

Figure 4. Ventilation Monitor Screen and System Controls

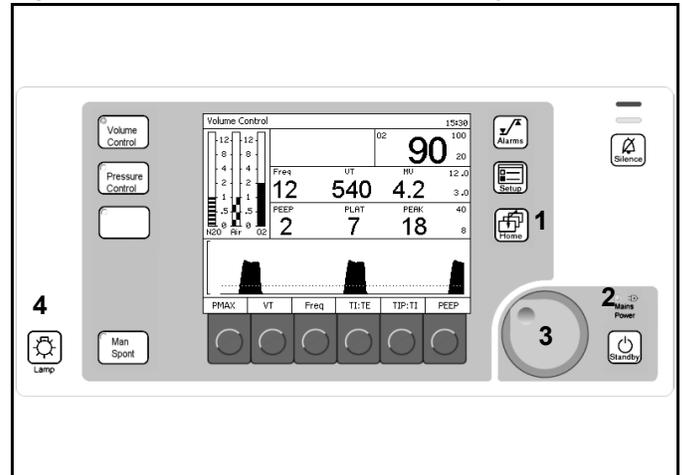

Cross-Functional Controls and Displays

Cross-functional controls and displays are used for both monitoring and ventilation functions.

Key LED Indicators

LED indicators (1 in Figure 5) within keys (Volume Control, Pressure Control, Man/Spont, Alarm Silence, and Standby) illuminate when that mode or function is selected and operating.

Figure 5. Ventilation Monitor Screen and System Controls

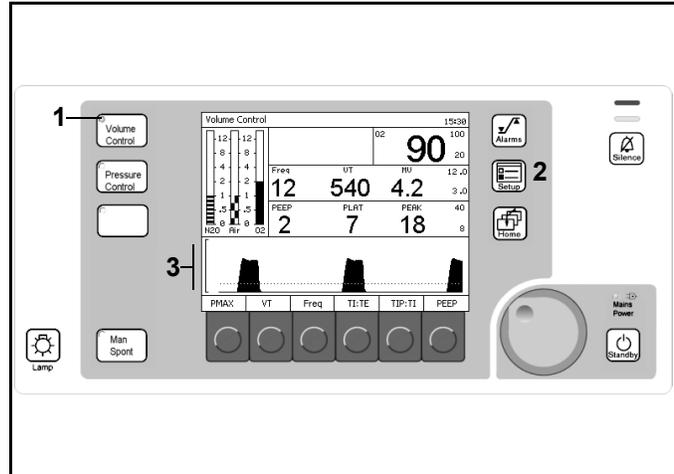

Setup Key

The Setup key is 2 in Figure 5.

Pressed During A Ventilation Mode

The Setup window (1 in Figure 6) replaces the Waveform area (3 in Figure 5).

The Setup window enables you to

- perform ventilation functions and
- view and change monitoring settings.

Figure 6. Setup Window

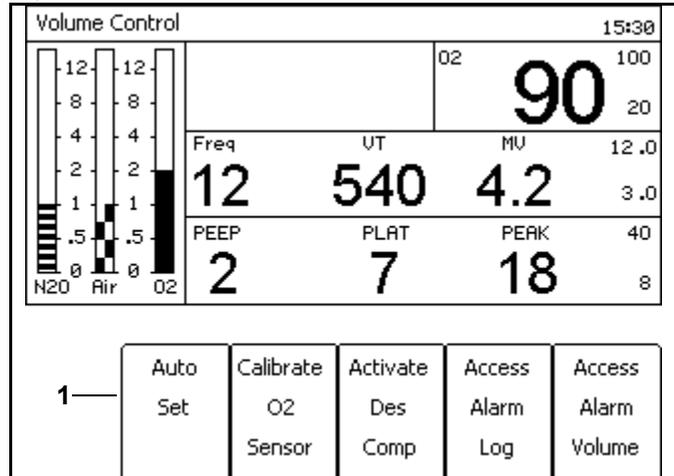
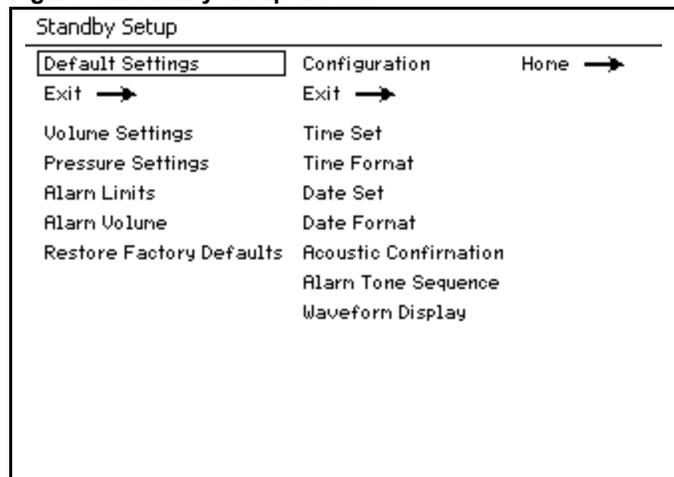

Figure 7. Standby Setup Screen



Pressed During Standby Mode

The Standby Setup screen (Figure 7) appears. The Standby Setup screen enables you to define site defaults and configuration.

Monitoring

Monitoring Controls

LED Indicators

LED lamps (1 in Figure 9) in the upper right corner of the control panel indicate the degree of urgency of currently active alarms.

- Warning — Red Blinking
- Caution — Yellow Blinking
- Advisory — Yellow Continuous

Silence Alarms Key

The Silence Alarms key (2 in Figure 9) silences all active alarm tones for 2 minutes. It resets the silence time for two minutes each time the key is pressed.

Alarm Limit Key

The Alarm Limit key (3 in Figure 9) displays the Alarm Limits window (1 in Figure 10), which appears in the same location on all mode screens.

Setup Key

The Setup key (4 in Figure 9) is a cross-functional control. See “Setup Key” on page 18.

Figure 9. Ventilation Monitor Screen and System Controls

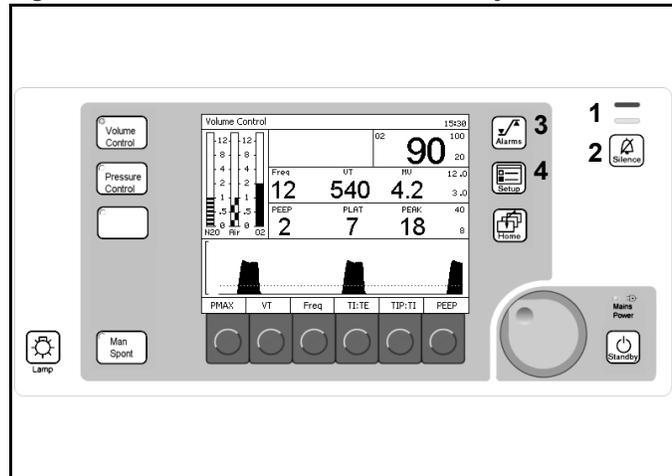
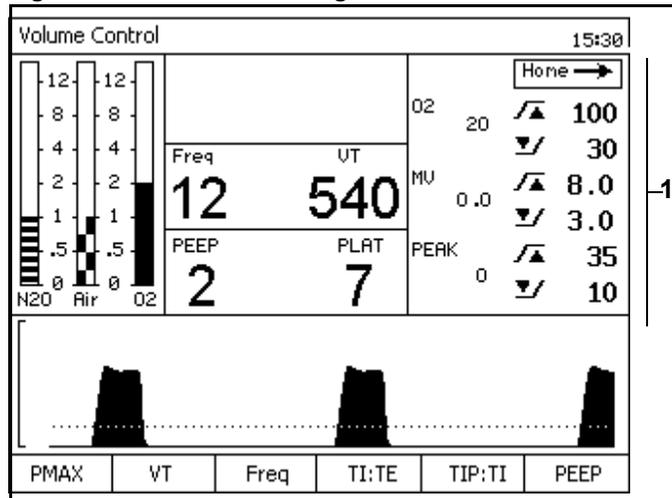

Figure 10. Alarm Limit Configure Window



Monitoring Windows

The following numbers in boldface refer to Figure 11.

Alarm Window

The Alarm window (1) displays up to four of the highest priority alarms.

Oxygen Monitor Window

The Oxygen Monitor window (2) displays the inspiratory oxygen concentration in units of percent (%). It also displays the oxygen alarm limits in the far-right section of this window.

Respiratory Volume Monitor Window

The Respiratory Volume Monitor window (3) displays the patient's frequency (breaths per minute) or respiratory rate, tidal volume, minute volume, the minute volume high alarm limit, and the minute volume low alarm limit.

Breathing Pressure Monitor Window

The Breathing Pressure Monitor window (4) displays the patient's positive end expiratory pressure (PEEP), mean airway pressure (MEAN) or plateau airway pressure (PLAT), and peak airway pressure (PEAK).

Breathing Pressure Trace Window

The Breathing Pressure Trace window (5) displays a trace, or waveform, of the patient's breathing pressure.

Figure 11. Monitor Screen

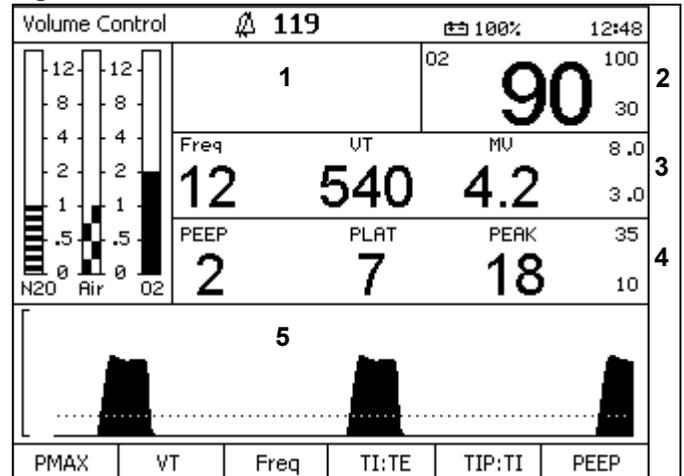

Selecting/Setting Monitoring Functions

The following example describes changing alarm limits on the Standby Setup Screen.

Example

1. Press the Setup key while the Standby Screen (Figure 12) is active. The Standby Setup screen (Figure 13) replaces the Standby Screen.
2. The rotary knob enables you to select the "Default Settings" or "Configuration" label. Select and confirm the "Default Settings" label.

The Default Settings column is selected (Figure 14).

Note: Selecting and confirming the return arrow (1 in Figure 13) will deactivate the Standby Setup screen and activate the Standby screen (Figure 12).

Note: Selecting and confirming the return arrow (1 in Figure 14) will deselect the Default Settings column and reselect the Default Settings label as in Figure 13.

Figure 12. Standby Screen

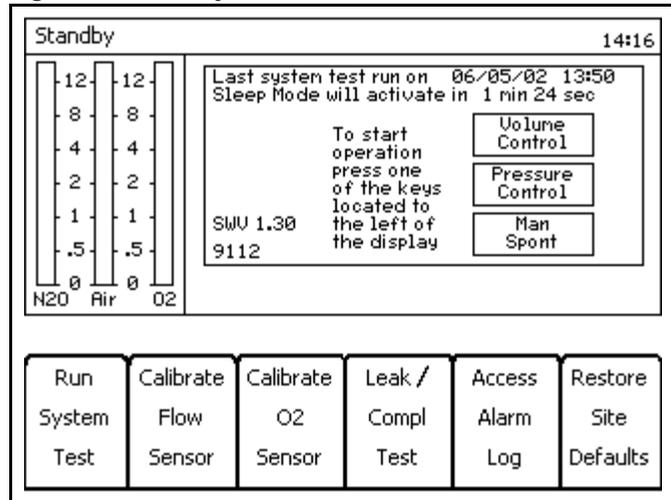

Figure 13. Standby Setup Screen

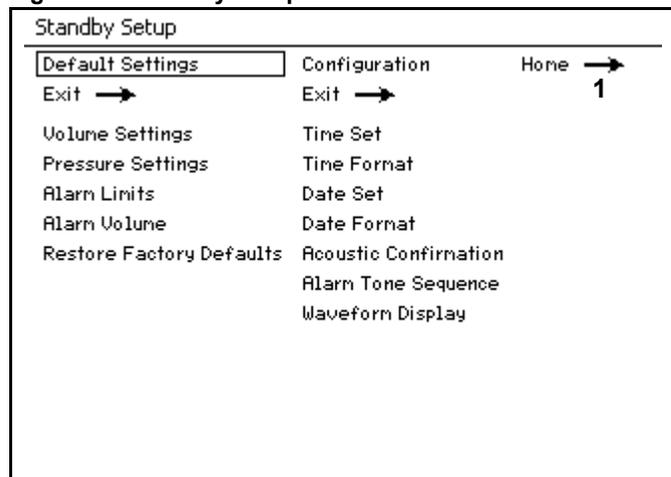
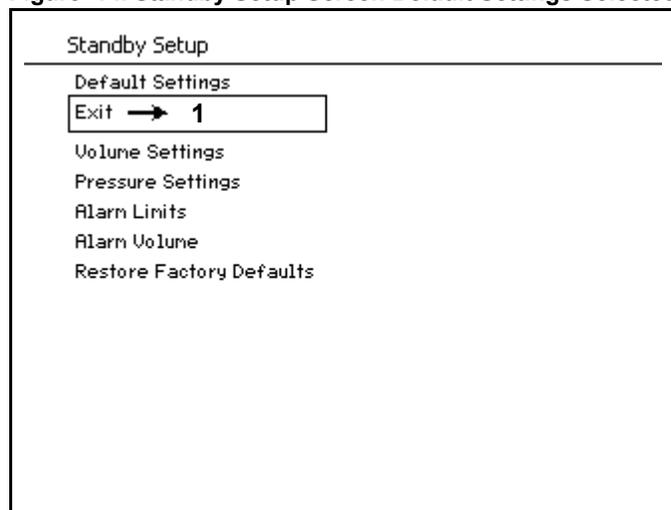
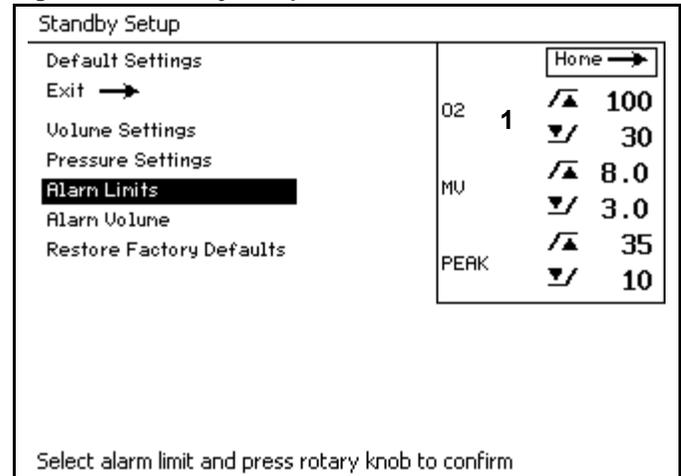

Figure 14. Standby Setup Screen Default Settings Selected



3. Select and confirm the "Alarm Limits" label.
The Default Alarm Limits window appears (1 in Figure 15).

Figure 15. Standby Setup Screen Default Alarm Limits



4. Select the alarm limit value that needs to change (Figure 16).

Figure 16. Standby Setup Screen Default Alarm Limits Select

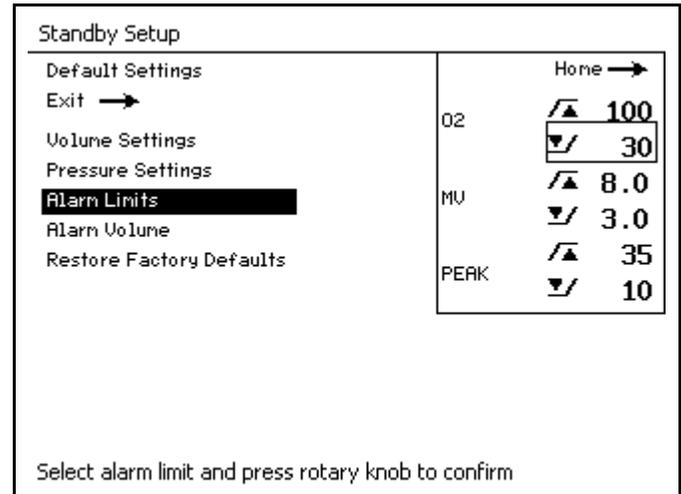

5. Confirm the alarm limit value and select a new value for the alarm limit (ex., in Figure 17, the value was changed from 30 to 25).
6. Confirm the new value for the alarm limit.
The new alarm limit value is saved and the cursor moves over the return arrow.

Figure 17. Standby Setup Screen Default Alarm Limits Confirm

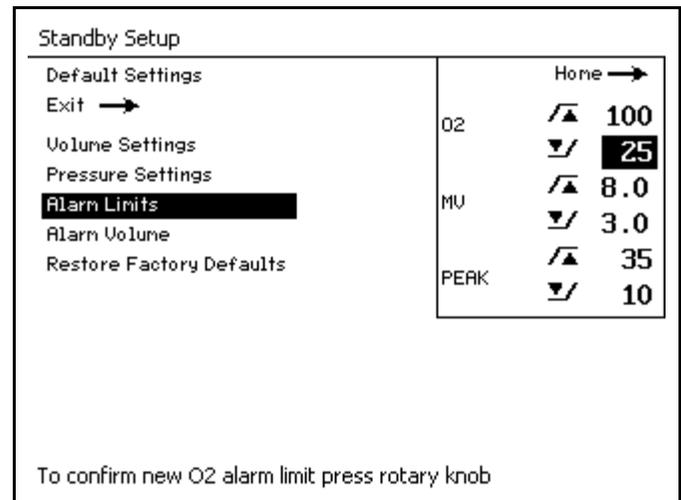

Ventilation

Ventilation Controls

The following numbers in boldface refer to [Figure 18](#).

Ventilation Mode Keys

Ventilation modes are selected by pressing one of the ventilation mode keys (**1**, **2**, **3**) and are confirmed by pressing the rotary knob. If the selection is not confirmed, the ventilation mode will not change.

Standby Key

The Standby key (**5**) switches the ventilator to standby mode.

Monitoring and alarms are turned off and the ventilator stops.

Setup Key

The Setup key (**4**) is a cross-functional control. See “[Setup Key](#)” on page 18.

Soft Keys

Soft keys (**6**) select ventilation parameters and functions.

Ventilator Compliance Compensation

Ventilator compliance compensation is continuously applied during Volume Control so that the tidal volume delivered to the patient corresponds to the Vt setting. Ventilator compliance is determined during the leak and compliance test performed from the Standby mode. To have compliance compensation work accurately, it is important that the patient hoses used during the leak/compliance test match the type of hoses used during the procedure.

Note: When the ventilator settings for Volume Control cause the ventilator to operate at its limits of performance, it is not possible for the Fabius GS to apply compliance compensation. If the ventilator’s performance limit is reached, it is not possible to increment the Vt setting via the Volume Control Settings window.

Figure 18. Ventilation Monitor Screen and System Controls

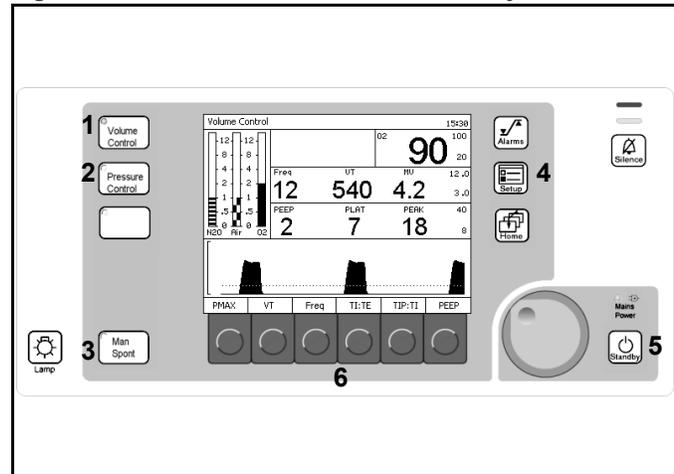

Ventilation Screens

Soft Key Labels

The following numbers in boldface refer to [Figure 19](#).

Each soft key (1) is associated with a ventilation parameter (2) that is associated with a specific ventilation mode (3).

Figure 19. Ventilation Monitor Screen and System Controls

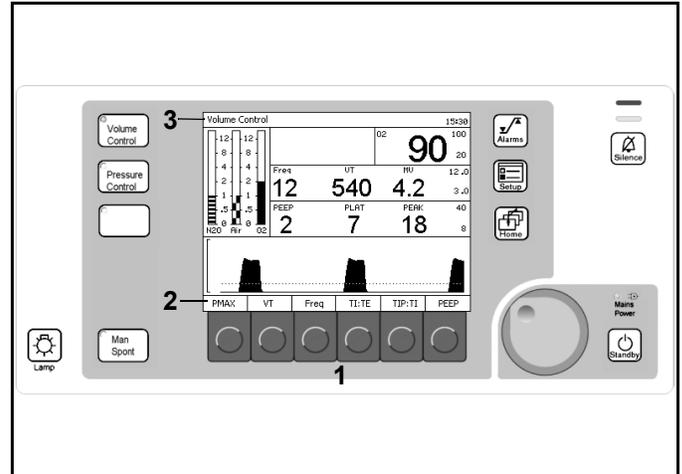

Volume Control Mode

The following soft key labels appear from left to right along the bottom of the Volume Control screen. See [Figure 20](#).

- **PMAX** (maximum ventilation pressure).
The range for PMAX is 15 to 70 cmH₂O.
The factory default value is 40 cmH₂O.
- **VT** (tidal volume).
The range for VT is 20 mL to 1400 mL.
The factory default value is 600 mL.
- **Freq** (ventilation frequency).
The range for Frequency is 4 bpm to 60 bpm.
The factory default value is 12 bpm.
- **Ti:Te** (time ratio between inspiration time and expiration time phases).
The range for Ti:Te is 4:1 to 1:4.
The factory default value is 1:2.
- **TiP:Ti** (relative inspiratory pause).
The range for TiP:Ti is 0% to 50%.
The factory default value is 10%.
- **PEEP** (positive end expiratory pressure).
The range for PEEP is 0 to 20 cmH₂O.
The factory default value is 0 cmH₂O.

Figure 20. Volume Control Ventilation Screen

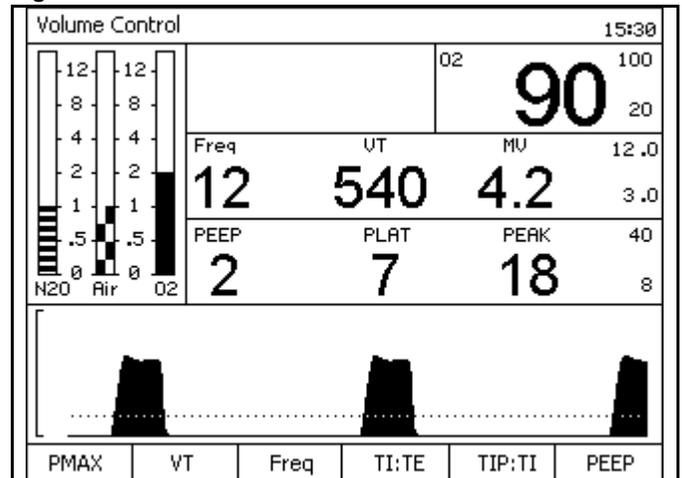

Pressure Control Mode

The following soft key labels appear from left to right along the bottom of the Pressure Control screen.

See [Figure 21](#).

- **PINSP** (inspiratory pressure setting).
The range for PINSP is 5 to 60 cmH₂O.
The factory default value is 15.
- **Freq** (ventilation frequency).
The range for Frequency is 4 bpm to 60 bpm.
The factory default value is 12 bpm.
- **TI:TE** (time ratio between inspiration and expiration phases).
The range for TI:TE is 4:1 to 1:4.
The factory default value is 1:2.
- **Insp Flow** (rate at which the piston travels upward to create the target pressure).
The range for Insp Flow is 10 L/min to 75 L/min.
The factory default value is 30 L/min.
- **PEEP** (positive end expiratory pressure).
The range for Peep is 0 to 20 cmH₂O.
The factory default value is 0 cmH₂O.

Figure 21. Pressure Control Ventilation Screen

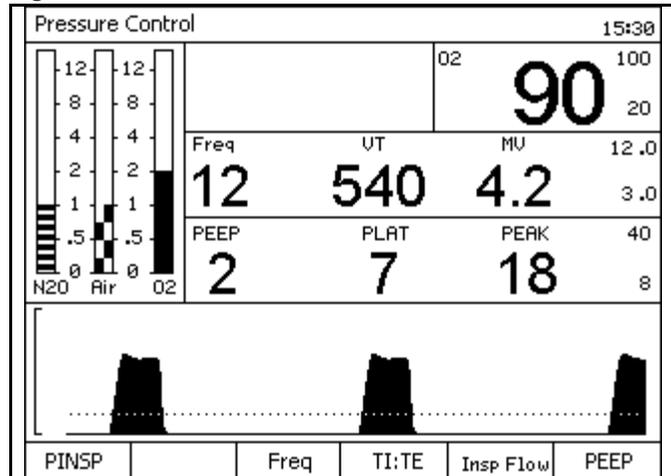

ManSpont Mode

The "Apnea Pressure" and "Volume Alarms" labels appear to the left of their ON/OFF label on the bottom of the ManSpont screen. See [Figure 22](#). Pressing the ON/OFF soft key turns the applicable alarm(s) "ON" or "OFF."

Figure 22. ManSpont Ventilation Screen

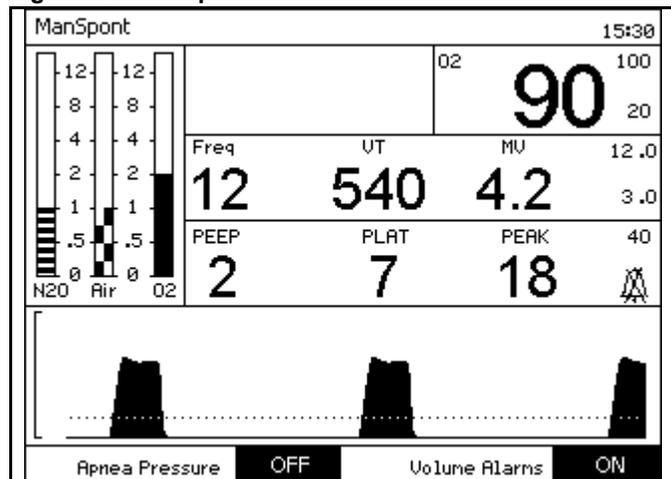

Ventilation

Chapter 3 - Operating Concept

Standby Mode

The following soft key labels appear from left to right along the bottom of the Standby screen.

See [Figure 23](#).

- Run System Test
- Calibrate Flow Sensor
- Calibrate O2 Sensor
- Leak / Compl Test
- Access Alarm Log
- Restore Site Defaults

See [“Standby Screen” on page 91](#) for details.

Flow Meter Monitor Window

The Flow Meter Monitor window is a graphical display of the flow rates of O₂, Air, and N₂O (L/min) (1 in [Figure 24](#)).

Note: On some non-U.S. units of the Fabius GS, the O₂ and N₂O virtual flow tubes have changed positions.

Figure 23. Standby Screen

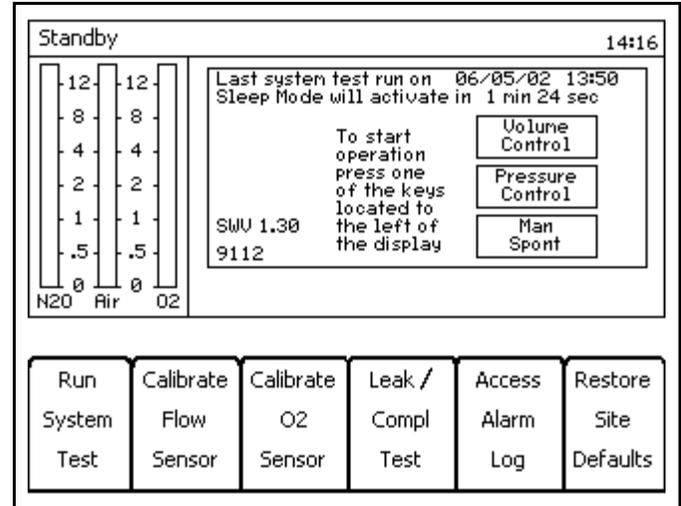
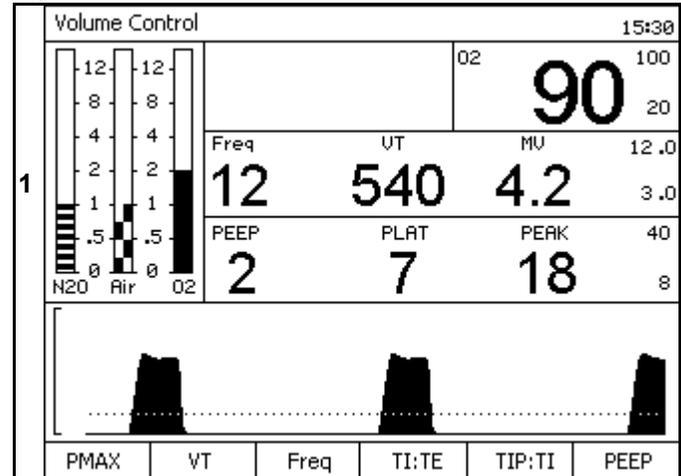

Figure 24. Flow Meter Monitor Window



Changing Ventilation Modes

Volume Control and Pressure Control

The following example describes changing

- from the present ventilation mode “Volume” (1 in Figure 25)
- to the desired ventilation mode “Pressure” (2 in Figure 25) with the desired ventilation settings (3 in Figure 25).

1. Press the Pressure Control key.

The LED associated with this key starts blinking (4 in Figure 25). It remains blinking until the selected mode of operation is confirmed.

A message appears (5 in Figure 25) that provides instructions to confirm the mode change.

The Waveform window is replaced by the Ventilator Settings window (6 in Figure 25) (Volume and Pressure modes only).

2. If the ventilation settings are correct, confirm the mode change.
3. If the ventilation settings are not correct, for each parameter that needs to change, press the corresponding soft key, select the correct value, and confirm the change.
4. When the parameter changes are completed, confirm the ventilation mode change.

After the mode change is confirmed, the Pressure Control key LED switches from blinking to constantly on, the ventilator switches to the selected operating mode, and the waveform is restored after a short delay.

Figure 25. Ventilator Mode Change Confirmation

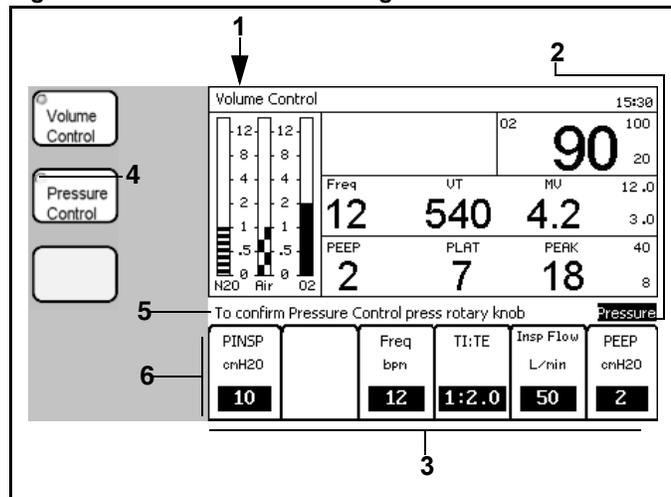

Ventilator Setting Selection

The ventilator settings for the new mode of operation are automatically derived from the settings and performance of the last confirmed automatic ventilation mode. Settings affected in the new mode will be highlighted (1 in Figure 26).

The settings for **Freq.**, **TI : TE**, and **PEEP** are taken directly from the settings used in the former mode.

When changing from Volume Control to Pressure Control, **Pinsp** is set to the Plateau pressure developed in Volume Control.

When changing from Volume Control to Pressure Control, the suggested value for **Insp. Flow** is either the last used value or the site default value.

When changing from Pressure Control to Volume Control, **VT** is set by dividing the last minute volume by the respiratory rate.

When changing from Pressure Control to Volume Control, the suggested value for **TIP : TI** is either the last used value or the site default value.

When changing from Pressure Control to Volume Control, **P_{MAX}** is set 10 cmH₂O higher than the plateau pressure developed during Pressure Control.

Figure 26. Ventilator Mode Change Settings

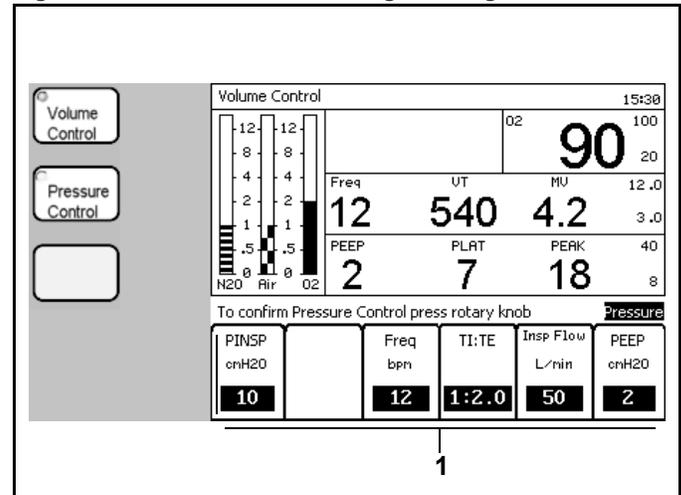

ManSpont

ManSpont (Manual/Spontaneous) is a non-automatic mode of ventilation. However, the ventilation monitor and alarms are still operational. In ManSpont mode, the ventilator piston is moved to its top-most position to minimize system compliance. Manual ventilation (with APL valve pressure limit) can be delivered with the APL valve switch in the MAN position. Spontaneous ventilation (APL valve wide-open) can occur with the APL valve in the SPONT position.

The following examples describe changing

- from the present ventilation mode “Volume” (1 in Figure 27)
- to the desired ventilation mode “ManSpont” (1 in Figure 28).

Spontaneous Breathing

1. Press the ManSpont key.

The LED associated with this key starts blinking (2 in Figure 27). It remains blinking until the selected mode of operation is confirmed.

The Waveform window is replaced by the ManSpont window (3 in Figure 27).

A message appears (4 in Figure 27) that provides instructions to confirm the mode change.

2. Confirm the mode change. The ManSpont screen is activated (Figure 28).

After the mode change is confirmed, the ManSpont key LED switches from blinking to constantly on and the waveform is restored after a short delay.

3. Set the toggle on the APL valve (1 in Figure 29) to the SPONT position.

4. Set the appropriate fresh gas flow.

Note: The ManSpont screen enables you to turn the Apnea Pressure alarm and Volume alarms ON or OFF.

Figure 27. Ventilator Mode Change to Man Spont

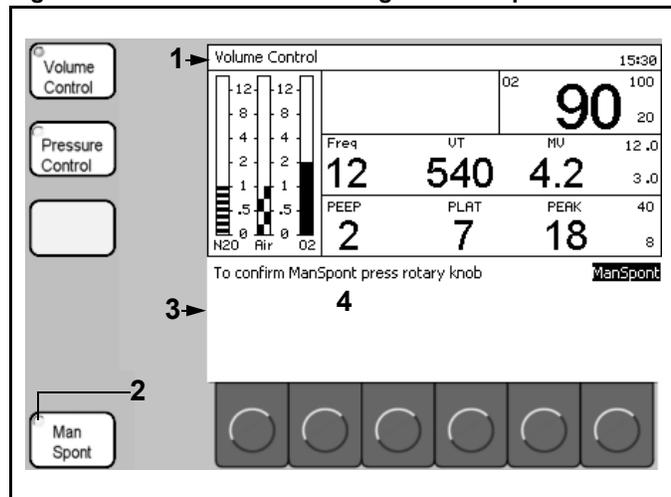

Figure 28. ManSpont Ventilation Screen

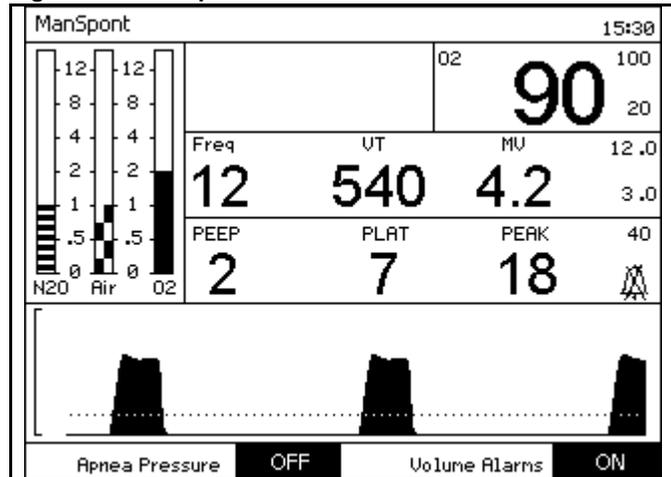

Figure 29. APL Valve



Manual Ventilation

Note: In ManSpont mode, the apnea volume timer countdown for caution alarms changes from 15 seconds to 30 seconds, and for warning alarms from 30 seconds to 60 seconds.

1. Press the ManSpont key.

The LED associated with this key starts blinking (1 in Figure 30). It remains blinking until the selected mode of operation is confirmed.

The Waveform window is replaced by the ManSpont window (2 in Figure 30).

A message appears (3 in Figure 30) that provides instructions to confirm the mode change.

2. Confirm the mode change. The ManSpont screen is activated (Figure 31).

After the mode change is confirmed, the ManSpont key LED switches from blinking to constantly on and the waveform is restored after a short delay.

Note: The ManSpont screen enables you to turn the Apnea Pressure alarm and Volume alarms ON or OFF.

3. Set the toggle on the APL valve (1 in Figure 32) to the MAN position.
4. Adjust the pressure limiting valve to set the appropriate value for the maximum ventilation pressure.
5. Press the O₂ flush button, as required, to inflate the bag.
6. Set the fresh gas flow.
7. Start manual ventilation.

Figure 30. Ventilator Mode Change to Man Spont

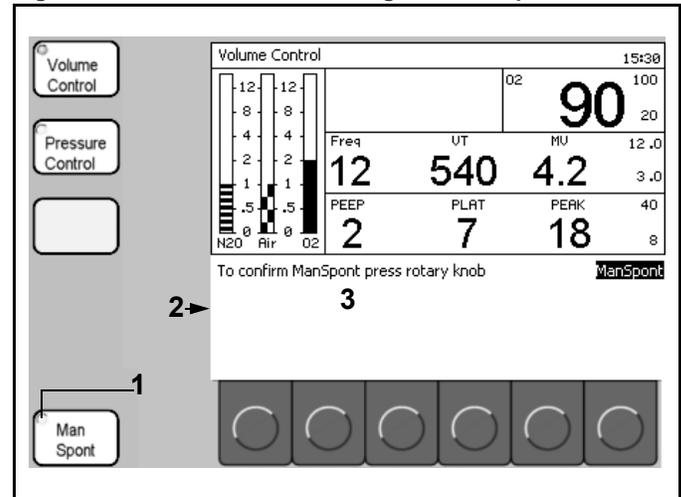

Figure 31. ManSpont Ventilation Screen

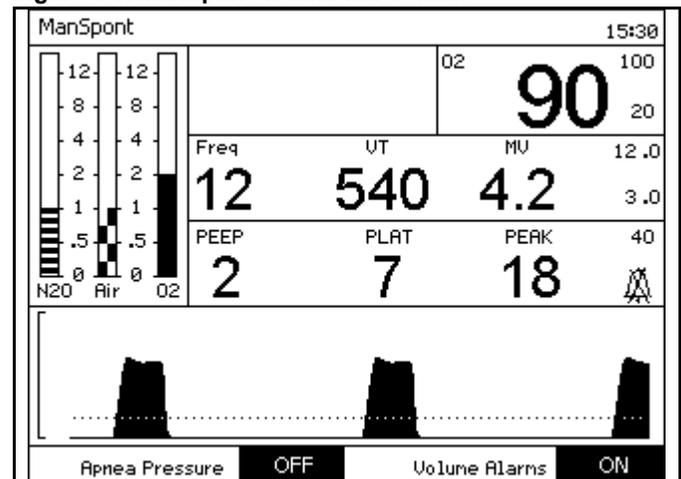

Figure 32. APL Valve



Selecting/Setting Ventilation Parameters

- In **Volume Control mode**, press the Volume Control key. The Volume Control Ventilation Settings window (1 in Figure 33) replaces the Waveform window.
- In **Pressure Control mode**, press the Pressure Control key. The Pressure Control Ventilation Settings Window (1 in Figure 34) replaces the Waveform window.

Figure 33. Volume Ventilator Settings Window

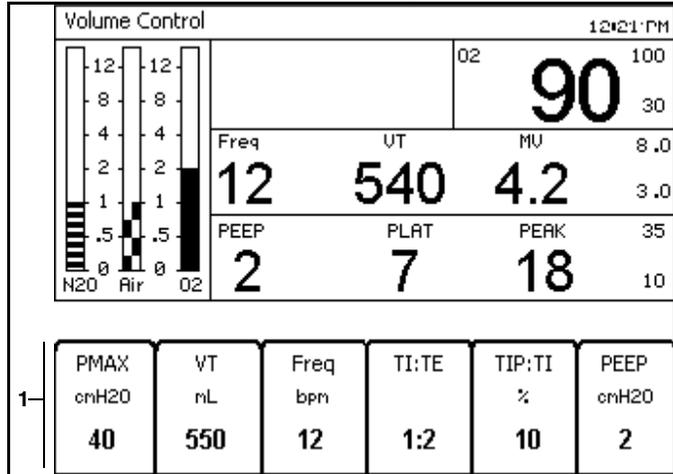

The following example continues in **Volume Control mode**.

- Press the VT (tidal volume) soft key. The Ventilator Settings window appears with the VT parameter label highlighted (1 in Figure 35).
- Select a new VT parameter setting.
- Confirm the new VT parameter setting.

Figure 34. Pressure Control Ventilator Settings Window

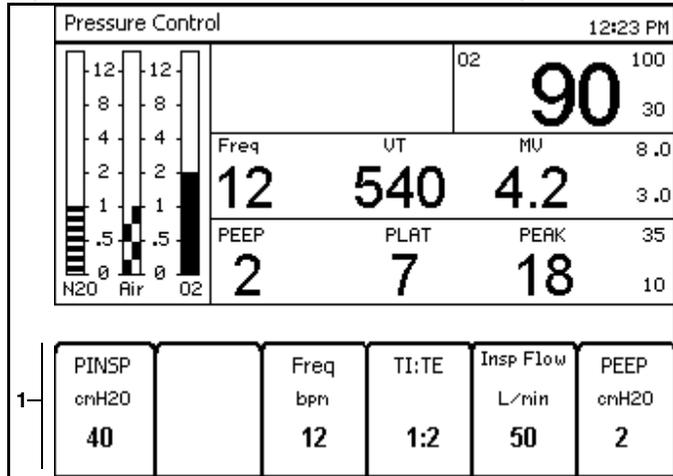

Note: Once the Ventilator Settings window is activated, it will return to the Waveform window if 15 seconds pass and neither the rotary knob nor a soft key is pressed.

If the Home key is pressed, the Ventilator Settings window will return to the Waveform window.

In either case, the ventilation parameter will remain as it was before it was activated in the Ventilator Settings window.

Figure 35. Volume Control Ventilator Label Selected

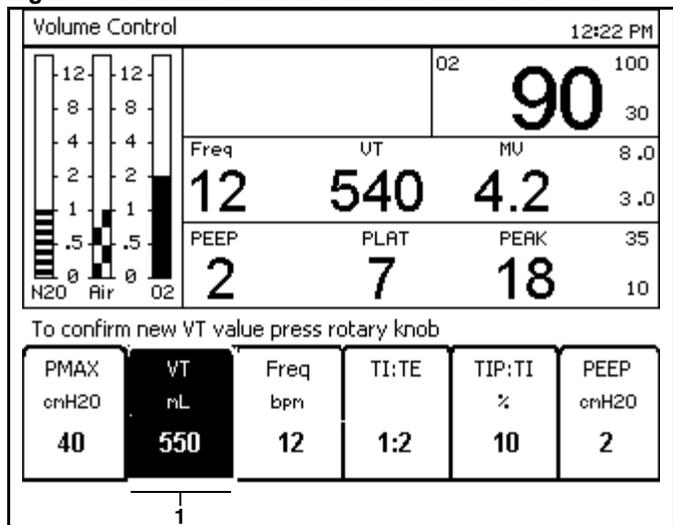

Fresh Gas Control

The following numbers in boldface refer to [Figure 36](#). Flow is increased when the **flow control knobs** (N₂O (1), AIR (2), O₂ (3)) are turned counterclockwise.

The **total flow meter** (4) displays the flow measurement of all of the applied gases combined.

Note: The total flow meter is calibrated for a 50/50 mixture of N₂O and O₂. The accuracy of the flow meter may degrade with other gas mixtures. (See the Technical Data section for specifications.)

The total flow meter serves two purposes. The total flow meter provides a reference of the **total** fresh gas applied to the breathing circuit. (Flow rate measurements for each individual gas; N₂O, Air, and O₂; are provided by their respective electronic flow indicator.)

Should a fault develop in the electronic flow sensing, digital display, or power circuitry, the total flow meter is still functional. The measurement will indicate the total flow rate prior to the fault condition.

To adjust the fresh gas ratios while under the fault condition, shut off all flows (O₂ may be left on), and then restore each gas flow individually. For example, start with 2 L/min O₂. The total flow meter will read 2 L/min.

If 1 L/min of N₂O is needed, open the N₂O flow control knob until the total flow meter reads 3 L/min - 2 L/min O₂ plus 1 L/min N₂O.

The **electronic fresh gas flow indicators** (N₂O (5), AIR (6), O₂ (7)) display the flow measurement of each gas.

Note: The electronic fresh gas flow meters are altitude corrected.

The **central supply pressure indicators** (N₂O (8), AIR (9), O₂ (10)) display the pressure measurement of each gas entering the Fabius GS from the facility's pipeline.

The **cylinder gauges** (O₂ (11), Air (12)) display the pressure measurement of each gas entering the Fabius GS from cylinders.

The **O₂ Low Supply Pressure Alarm LED** (13) flashes when the O₂ supply is below the factory set minimum pressure, nominally 20 psi (1.4 bar).

Figure 36. Flowmeter and Pressure Gauge Assembly

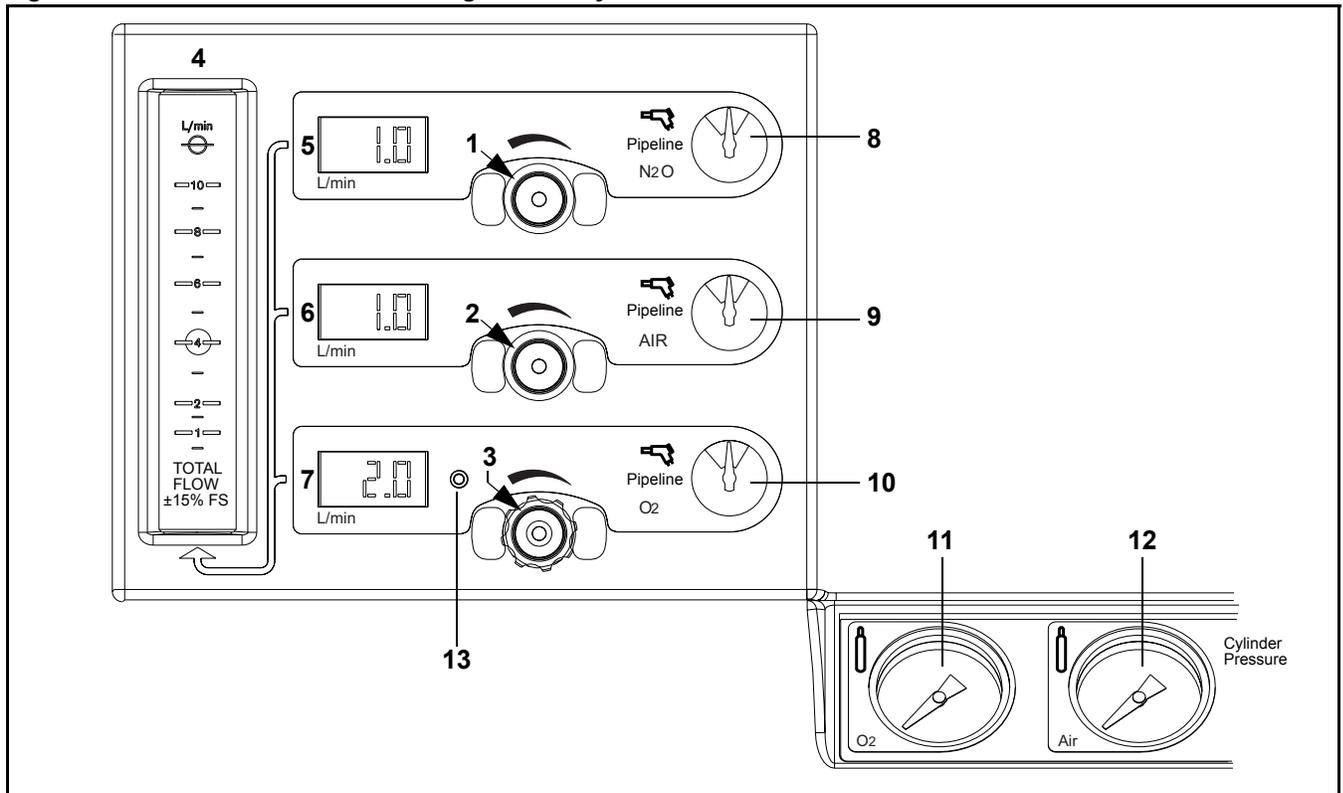

Fresh Gas Flow Monitoring Resolutions

The Fabius GS can be configured by your Local Authorized Service Organization to display fresh gas flow rates either in a standard resolution mode or in a high resolution mode.

Standard Resolution

If standard resolution is configured (Figure 37), the numeric displays (LEDs) for the fresh gas flow rates support 100 ml/min. increments (format xx.x l/min.) and the flow meters on the monitor screen indicate a range of 0 to 12 l/min.

High Resolution

If high resolution is configured (Figure 38), the numeric displays (LEDs) for the fresh gas flow rates support 10 ml/min. increments (format x.xx l/min.) and the flow meters on the monitor screen indicate a range of 0 to 10 l/min. with an emphasis on resolution at the lower end of the scale.

High-resolution data is displayed when all individual gas flows are below 9.99 l/min.

Switching to standard resolution occurs when the highest flow rate is greater than 9.99 l/min.

Switching to high resolution occurs when the highest flow rate drops below 9.00 l/min.

Figure 37. Standard Resolution Fresh Gas Flow Monitoring

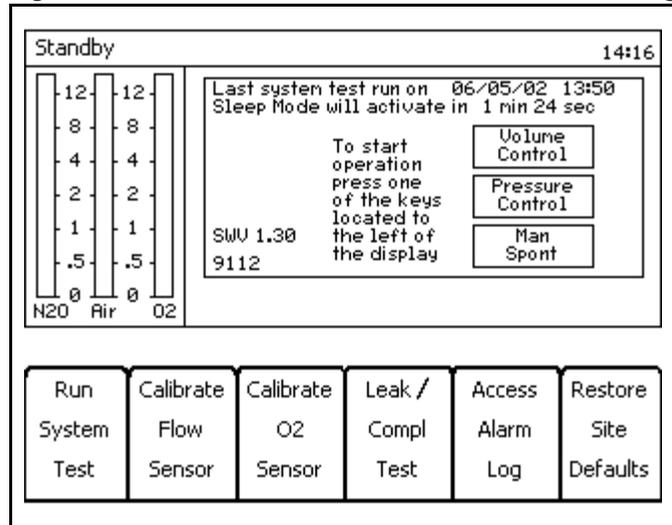
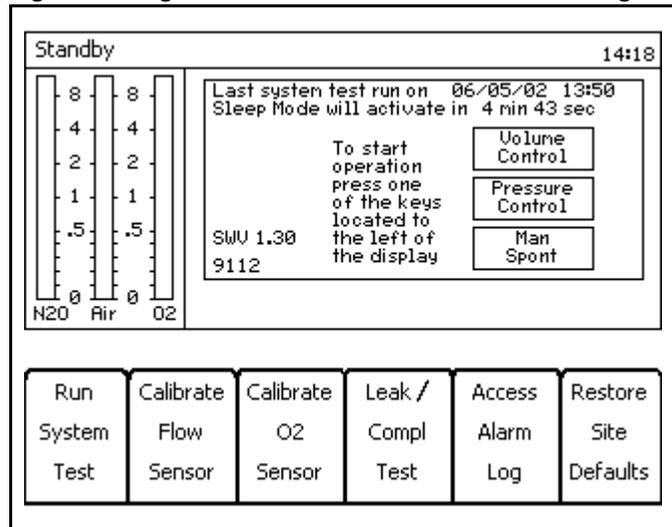

Figure 38. High Resolution Fresh Gas Flow Monitoring



APL Valve

The following numbers in boldface refer to **Figure 39**.

The APL valve (**1**) has two functions. It limits the maximum pressure during manual ventilation. It also exhausts excess gas into the scavenger system during manual and spontaneous ventilation.

The APL valve is connected to the patient airway through the ventilator. It functions only when the ventilator is in ManSpont mode or ventilator override condition.

The APL valve has a toggle switch (**2**) for selecting between manual and spontaneous modes of ventilation.

When the side of the switch marked MAN is up, the APL valve sets maximum pressure for manual ventilation. When the side marked SPONT is up, pressure is released for spontaneous ventilation. Depressing the switch while in the MAN position will also temporarily relieve pressure.

Maximum pressure adjustment is made by rotating the APL valve adjustment (**3**) when the toggle switch is in the MAN position to set peak airway pressure. The adjustment housing is labelled to indicate pressure settings. Rotating the adjustment counterclockwise reduces the peak inspiratory pressure and the pressure at which gas is released to the scavenging system. Rotating the adjustment clockwise increases the peak inspiratory pressure and the pressure at which gas is released to the scavenging system.

During spontaneous ventilation, resistance to patient exhalation is automatically eliminated by toggling to the SPONT position, which eliminates the need to re-adjust backpressure.

Figure 39. APL Valve

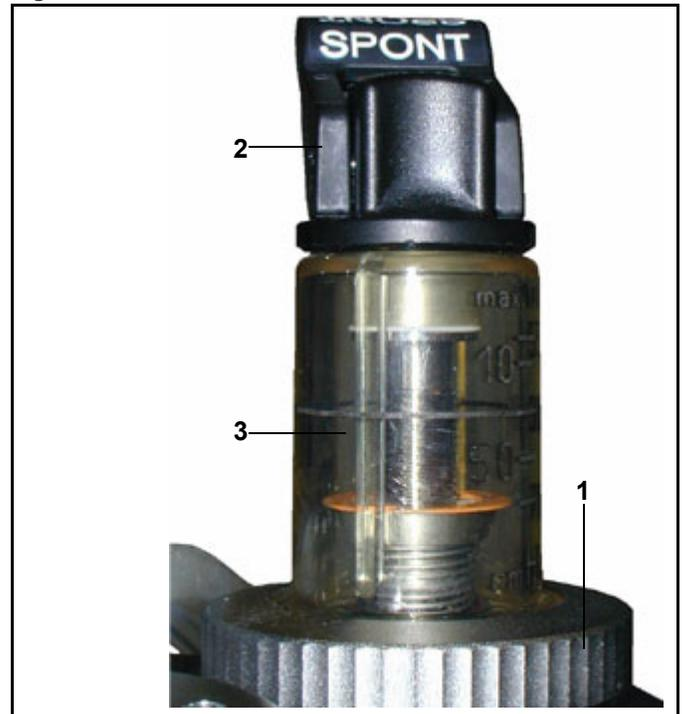

Preparation

Contents

Activating the Battery	39
Gas Supply	39
Medical Gas Pipeline Supply of O ₂ , N ₂ O, and AIR	39
Cylinders with Pin-index Mounting	40
Electrical Supply	41
Attaching Manual (Ambu) Ventilation Bag	41
Preparing the Ventilator	42
Ventilator Safety Features	42
Attaching the CO ₂ Absorber onto the Compact Breathing System	43
Attaching the Inspiratory Valve	43
Attaching the Expiratory Valve	43
Attaching the Adjustable Pressure Limiting (APL) Valve	44
Inserting the Flow Sensor	44
Attaching the Waste Gas Outlet Port	44
Connecting the Compact Breathing System	45
Connecting the Breathing Hoses	46
Inserting A New O ₂ Sensor Capsule	46
Connecting the O ₂ Sensor	47
Connecting the Pressure Sensor	47
Connecting the Breathing Pressure Gauge	48
Connecting the APL Bypass and Peep/PMAX Hoses	48
Connecting the Flow Sensor	49
Installing Anesthetic Gas Scavenging Hose to the Compact Breathing System	49
Scavenger System for Fabius GS	50
Daily and Preuse Checkout Form	50

Note: Complete the Periodic Manufacturer's Service procedure (SP00225) after you set up the Fabius GS anaesthesia machine.

Activating the Battery

The Fabius GS anesthesia machine is shipped with the battery fuse disconnected in order to prevent discharge during shipment and storage prior to installation.

1. Remove the battery fuse from the top drawer of the Fabius GS.
2. Remove the battery fuse from its packaging.
3. Insert the battery fuse into the battery fuse holder (1 in [Figure 40](#)) (turn the fuse 1/4-turn clockwise until it is snug).

Figure 40. Battery Fuse

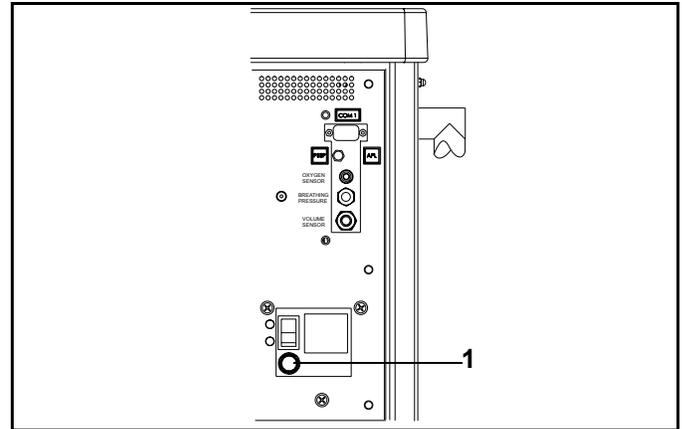

Gas Supply

Note: Medical gases must be dry and free from dust and oil.

The central gas supply gas connections are shown in [Figure 41](#).

Figure 41. 3-Gas Supply Connections

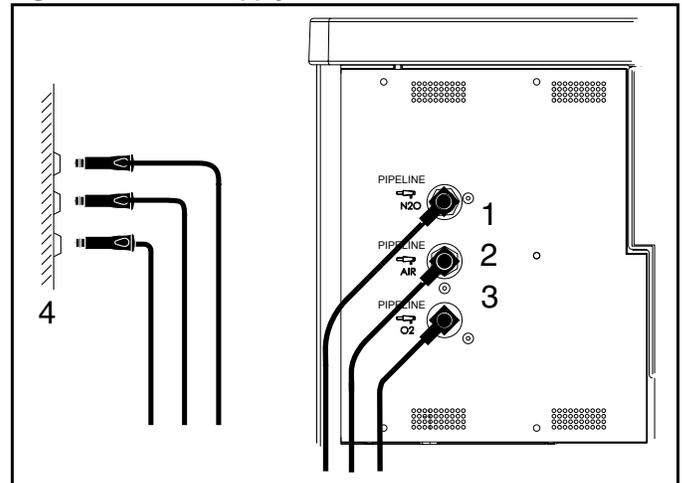

Medical Gas Pipeline Supply of O₂, N₂O, and AIR

Warning: Carefully check hoses each time you connect a machine to a wall or ceiling outlet to ensure that both ends of the hose are indexed for the same gas. Pipeline delivery hoses used between wall outlets and anesthesia machines have caused accidents when, during assembly, an oxygen fitting was placed on one end of the hose and a nitrous oxide fitting on the other end.

The following numbers in boldface refer to [Figure 41](#).

1. Connect the N₂O hose (**1**) to the connector on the Fabius GS and to the wall terminal unit (**4**) of the medical gas pipeline system.
2. Connect the AIR hose (**2**) to the connector on the Fabius GS and to the wall terminal unit (**4**) of the medical gas pipeline system.
3. Connect the O₂ hose (**3**) to the connector on the Fabius GS and to the wall terminal unit (**4**) of the medical gas pipeline system.

Cylinders with Pin-index Mounting

Warning: When attaching a cylinder, ensure that only one washer is installed between the cylinder and the yoke gas inlet. The use of multiple washers will inhibit the pin-index safety system. Be sure to verify the presence of the index pins each time a cylinder is installed. Never attempt to override the pin-index safety system.

Caution: Do not oil or grease the O₂ cylinder valves and O₂ pressure regulator. There is a risk of explosion.

If cylinder valves are leaky or difficult to open or close, they must be repaired in accordance with the manufacturer's specifications.

Even if the gas supply is connected to a medical gas pipeline, the cylinders should remain on the device in reserve.

The following numbers in boldface refer to [Figure 42](#).

To connect a gas cylinder (**1**) to its yoke:

1. Remove the old washer (**2**) and install a new washer on the seat of the yoke gas inlet connection.
2. Verify that the two index pins (**3**) below the gas inlet (**4**) are present.
3. Insert the head (**5**) of the gas cylinder into the yoke from below. Ensure that the gas outlet and indexing holes on the cylinder head align with the gas inlet and index pins of the yoke assembly (**6**).
4. Engage the indexing holes with the index pins.
5. Turn the yoke handle (**7**) clockwise against the cylinder head, so that the point of the yoke handle bolt is aligned with the indent on the back of the cylinder head.
6. Verify that the washer is in place, the index pins are engaged, and the cylinder hangs vertically.
7. Tighten the yoke firmly.
When required, the cylinder valve (**8**) is opened using the cylinder wrench (**9**) that is provided.
8. When a cylinder is removed, place the yoke plug (**10**) in the yoke assembly and tighten.

Figure 42. Pin Index Cylinder Mounting

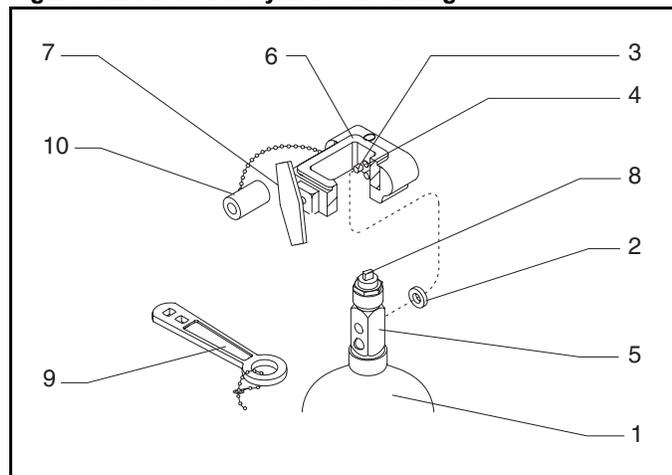

Cylinders attached to the hanger yokes must contain gas at the recommended pressures outlined in [Table 1](#). (Indicated pressures are of E-size cylinders at 70° F, or 21° C.) Cylinders measuring less than the minimum recommended pressure (PSI - MIN) should be replaced with new, full cylinders.

Table 1. Recommended Cylinder Gas Pressures

GAS	PSI/bar - FULL (typical full load)	PSI/bar - MIN
Air	1900/131	1000/69
Nitrous Oxide	745/51	600/42
Oxygen	1900/131	1000/69

Electrical Supply

Fabius GS can be operated at mains voltages from 100 V to 240 V.

Push power plug into supply mains socket.

Switch on the machine. The system power switch (1 in [Figure 43](#)) is on the rear of the machine.

Figure 43. Power Switch

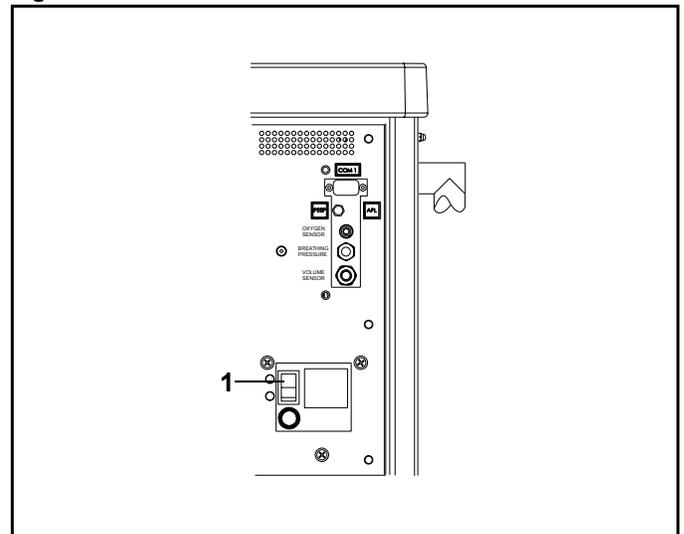

Attaching Manual (Ambu) Ventilation Bag

Hang the fully prepared and tested bag on the rail at the right (1).

Figure 44. Manual (Ambu) Ventilation Bag

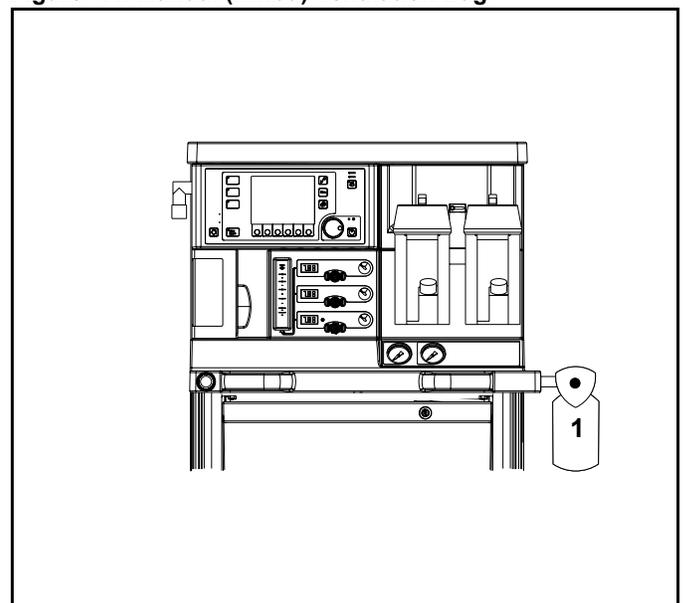

Preparing the Ventilator

Use only disinfected/sterilized components.

The following numbers in boldface refer to [Figure 45](#).

1. Swing out the ventilator door (1).
2. Unlatch the three clasps (2) to remove the cover (3).
3. Insert the diaphragm (4).
4. Fit the cover (3) and lock the three clasps.
5. Connect the ventilator chamber pressure sensor line (5) to the ventilator chamber pressure sensor line port (6).
6. Swing the ventilator unit (1) back into position.

Figure 45. Ventilator Assembly

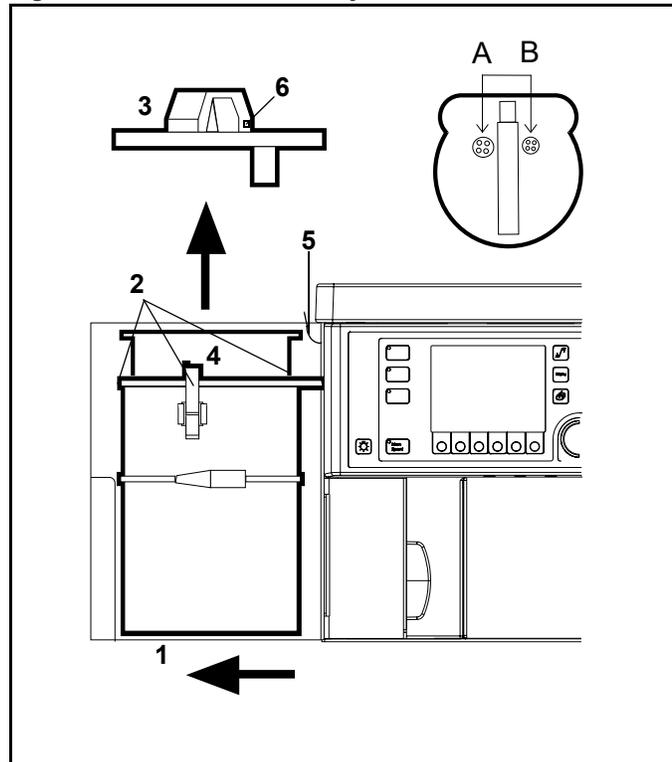

Ventilator Safety Features

- High pressure safety relief valve (A)
- Negative pressure safety relief valve (B)
- Ventilator chamber pressure sensor

Caution: Fabius GS anesthesia machines that were shipped with a SW version 1.1x or 1.20 have a 3-cmH₂O negative pressure relief valve in the ventilator cover. These ventilator covers must not be used with machines equipped with software version 1.30 or higher. Machines with software version 1.30 or higher require a ventilator cover with an 8-cmH₂O negative pressure relief valve. These ventilator covers have a smaller locating pin. The two covers are not interchangeable. Using an incorrect ventilator cover on a Fabius GS could cause a ventilator malfunction. (All units with SW version 1.1x or 1.20 can be upgraded to SW version 1.30.)

Attaching the CO₂ Absorber onto the Compact Breathing System

1. Remove the absorber canister (see [“Replacing CO₂ Absorbent”](#) on page 56 for more information).
2. Fill the absorber with fresh CO₂ absorbent to the fill line. Dräger Medical, Inc. recommends the use of Dräger sorb 800 Plus.
3. Ensure that no CO₂ absorbent dust/particles have been deposited between the gaskets and the sealing surfaces. Such dust and particles can cause leaks in the system.
4. Tighten the absorber by turning it to the right into the compact breathing system.

Figure 46. CO₂ Absorber

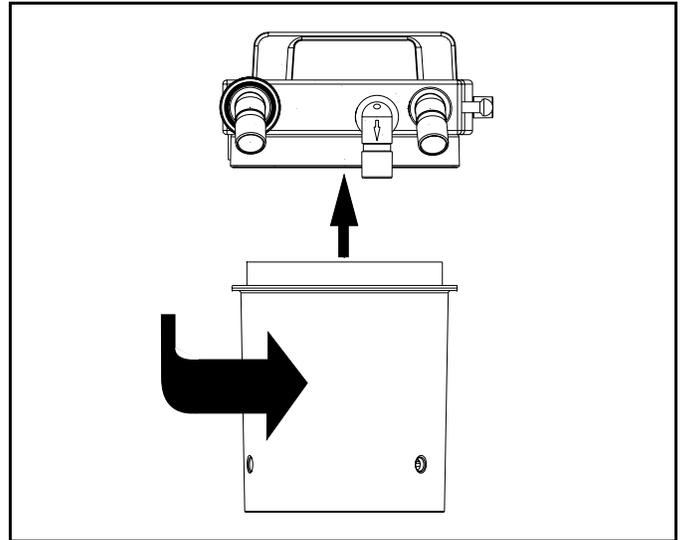

Attaching the Inspiratory Valve

The following numbers in boldface refer to [Figure 47](#).

1. Place the valve disc (**3**) in the valve seat.
2. Place the gasket (**4**) on top of the valve disc.
3. Fit the inspection cap (with port) (**5**).
4. Tighten the retaining nut (**6**) securely.

Figure 47. Inspiratory/Expiratory Valves

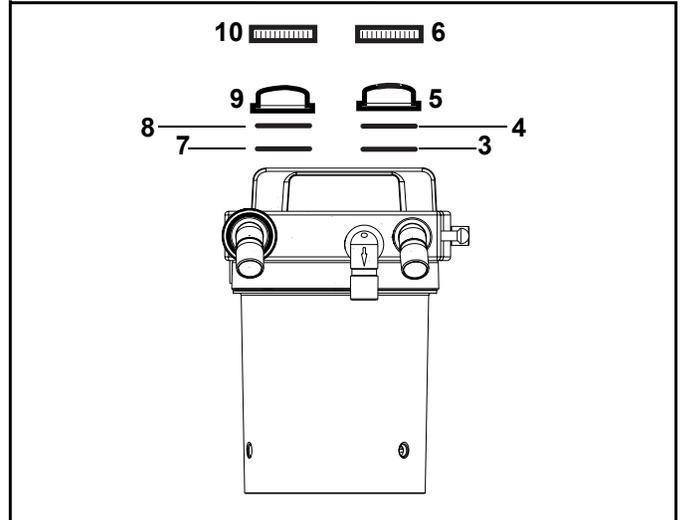

Attaching the Expiratory Valve

The following numbers in boldface refer to [Figure 47](#).

1. Place the valve disc (**7**) in the valve seat.
2. Place the gasket (**8**) on top of the valve disc.
3. Fit the inspection cap (**9**).
4. Tighten the retaining nut (**10**) securely.

Attaching the Adjustable Pressure Limiting (APL) Valve

Tighten the pressure-limiting valve (**9** in [Figure 48](#)) securely into place with the retaining nut.

Figure 48. APL Valve

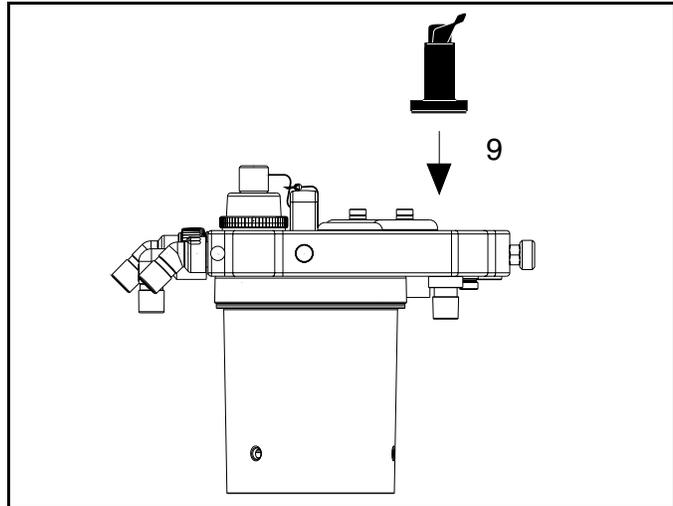

Inserting the Flow Sensor

The following numbers in boldface refer to [Figure 49](#).

1. Unscrew and remove the expiration port (**1**).
2. Insert the flow sensor (**2**).
3. Reinstall the expiration port (**1**).

Attaching the Waste Gas Outlet Port

Screw the waste gas port into the compact breathing system from underneath (**3** in [Figure 49](#)).

Figure 49. Flow Sensor Assembly

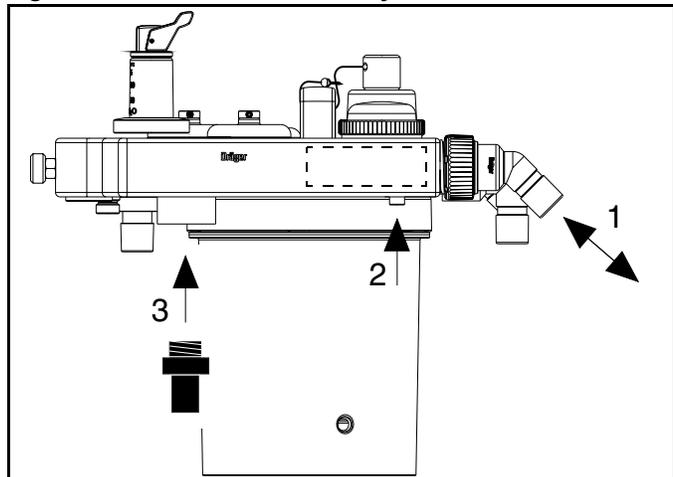

Connecting the Compact Breathing System

The following numbers in boldface refer to [Figure 50](#) and [Figure 51](#).

Caution: The sealing rings on the threaded and conical connectors (**5** and **6**) must be undamaged and clean.

Caution: Only hand-tighten the threaded connectors. Do not use tools.

1. Pull and hold plunger (**1**) out to its full extension on the compact breathing system.
2. Fit the compact breathing system onto the compact breathing system mount (**2**).
3. Release the plunger (**1**) and rotate the compact breathing system until the plunger locks into position.
4. Screw the fresh gas hose from the Fabius GS (**3**) to the compact breathing system (**4**).
5. Screw the ventilation hose to the ventilator (**5**) and attach it to the conical connector ventilator port on the compact breathing system (**6**).

Figure 50. Compact Breathing System Installation

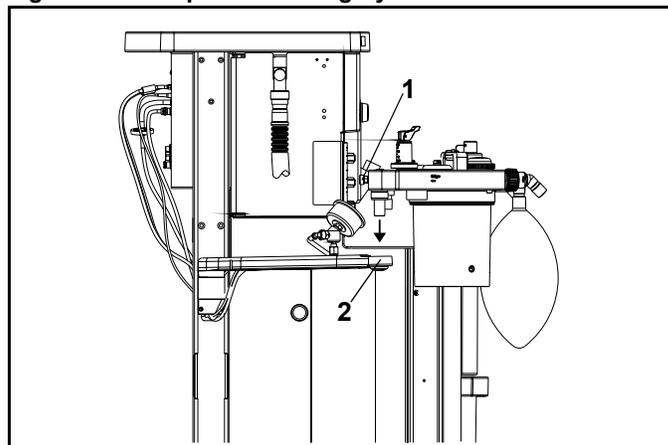
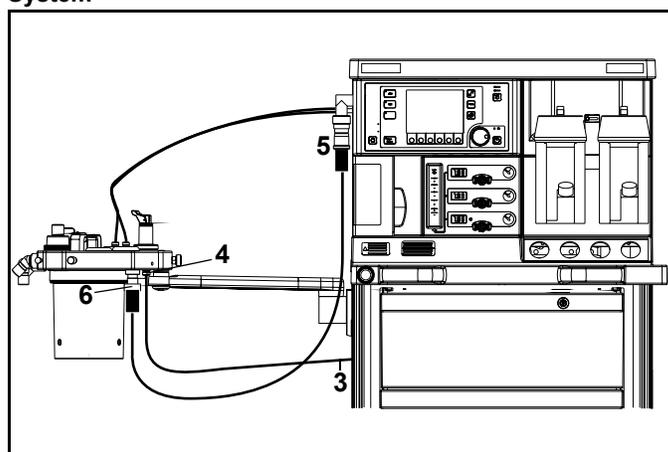

Figure 51. Hose Connections for Compact Breathing System



Connecting the Breathing Hoses

Note: Take care not to damage the breathing hoses.

When connecting and disconnecting, always hold the breathing hoses by the end sleeve, not by the spiral reinforcement (Figure 52). Otherwise, the spiral reinforcement may be torn loose.

Breathing hoses with a damaged spiral reinforcement can kink or become occluded.

Before each use, check the breathing hoses for damage.

Figure 52. Breathing Hose Handling Caution

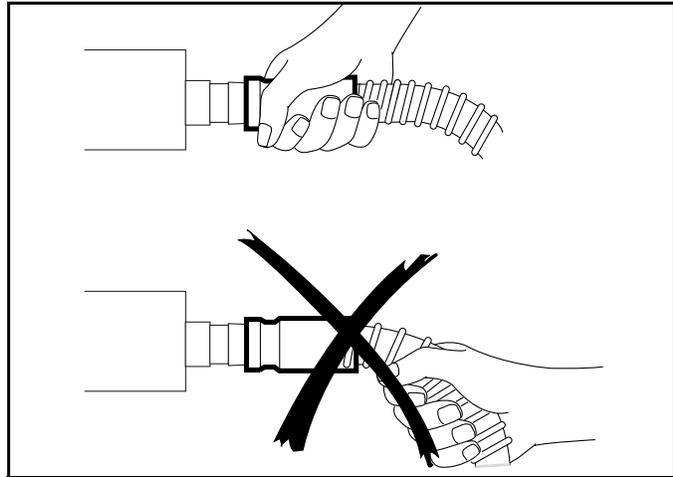

The following numbers in boldface refer to Figure 53.

1. Push patient breathing hoses (1) onto both the inspiratory and expiratory connectors or onto the microbial filters.
2. Connect both patient breathing hoses to the Y-piece (2).
3. Connect the bag (3) to the elbow port on the compact breathing system.

Figure 53. Installing Breathing Hoses

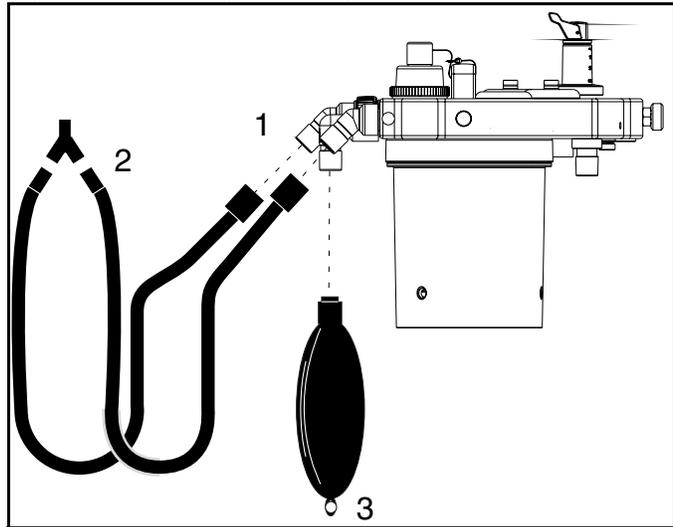

Inserting A New O₂ Sensor Capsule

Inserting a new O₂ sensor capsule:

The following numbers in boldface refer to Figure 54.

1. Unscrew the cap (1) from the sensor housing.
2. Remove the new sensor capsule from its packaging, or use a disinfected sensor capsule.
3. Insert the capsule (2) in the housing, with the ring-shaped conductors against the contacts in the housing.
4. Screw the cap (1) on firmly by hand.

Figure 54. O₂ Sensor Capsule Assembly

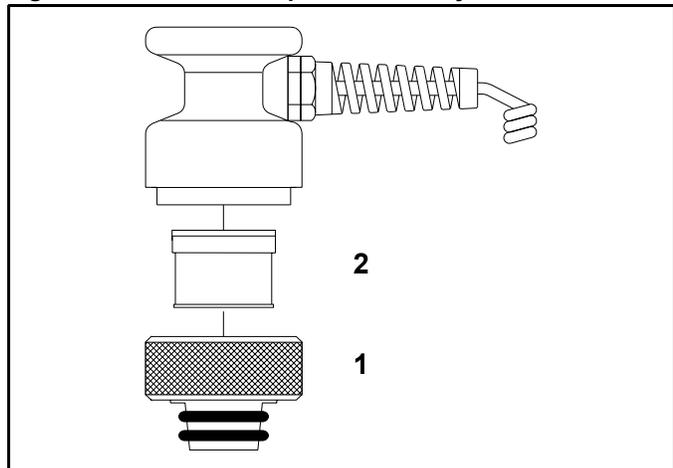

Connecting the O₂ Sensor

The following numbers in boldface refer to [Figure 55](#).

Push the O₂ sensor into the port opening of the inspiratory port dome (1), and plug the connector into the connector panel.

Figure 55. Connecting the O₂ Sensor Capsule

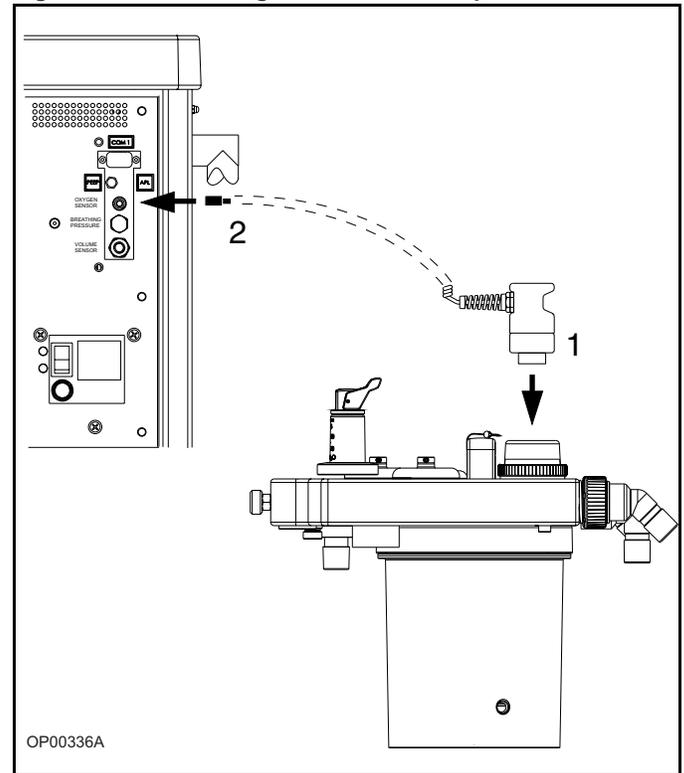

Connecting the Pressure Sensor

The following numbers in boldface refer to [Figure 56](#).

Press the pressure measuring line hose onto the hose barb (1) until it engages.

Caution: Do not squeeze the pressure measuring line hose when pressing it onto the hose barb.

Connect the pressure measuring line hose to the bacterial filter (2) and plug it firmly onto the port on the connector panel.

Figure 56. Pressure Sensor Connections

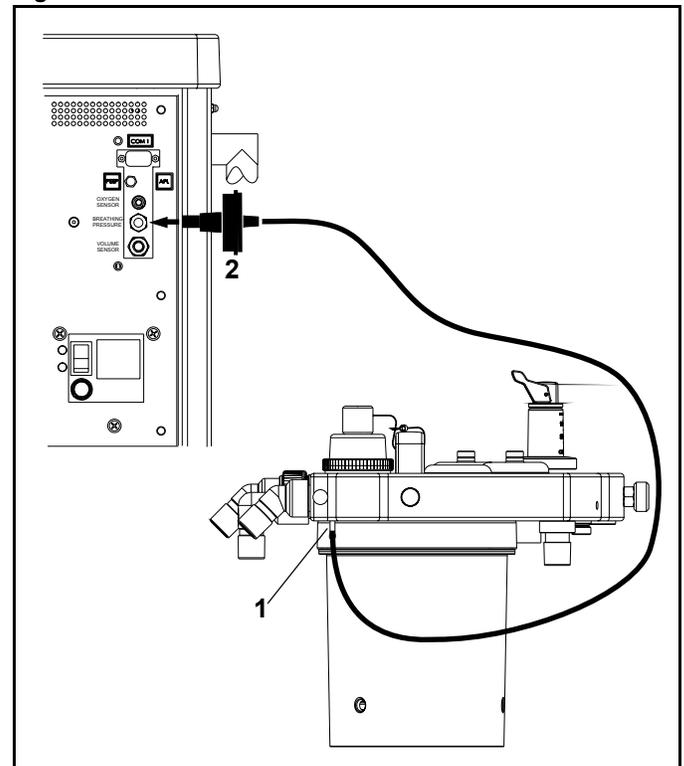

Connecting the Breathing Pressure Gauge

1. Connect the pressure gauge (1) to the compact breathing system mount (2) and secure with the retaining screw (3) and lockwasher (4).

Push the pressure measuring line hose onto the hose barb (5), the breathing pressure gauge port (6), and onto the port on the connector panel (7).

Figure 57. Breathing Pressure Gauge

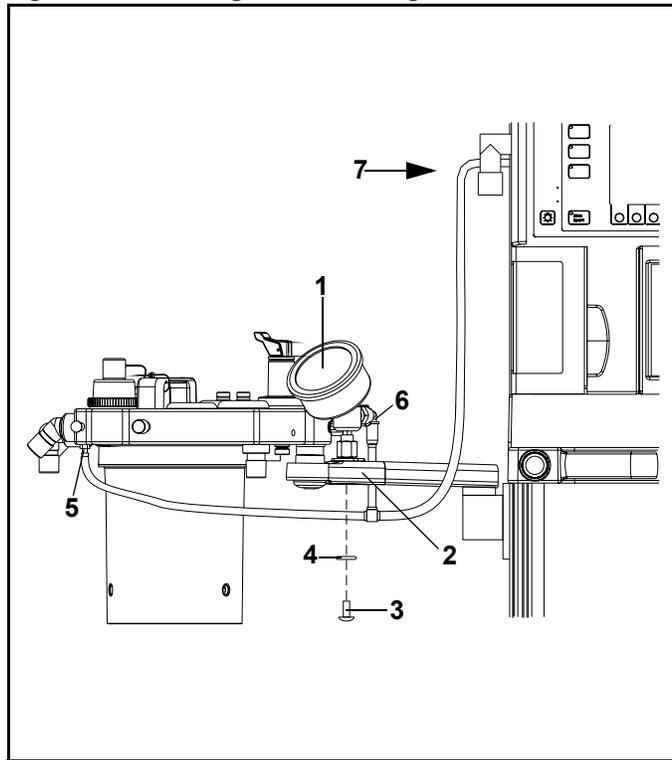

Connecting the APL Bypass and Peep/P_{MAX} Hoses

The following numbers in boldface refer to [Figure 58](#).

1. Plug the control hose to the connection port on the PEEP/P_{MAX} valve (1) and to the connection port marked "PEEP" on the connection panel (2).
2. Plug the control hose to the connection port on the APL Bypass valve (3) and to the connection port marked "APL" on the connection panel (4).

Note: The control hoses are connected together near the end of each hose. The APL bypass hose is larger than the PEEP/P_{MAX} hose.

Figure 58. APL Bypass and Peep Hose Connections

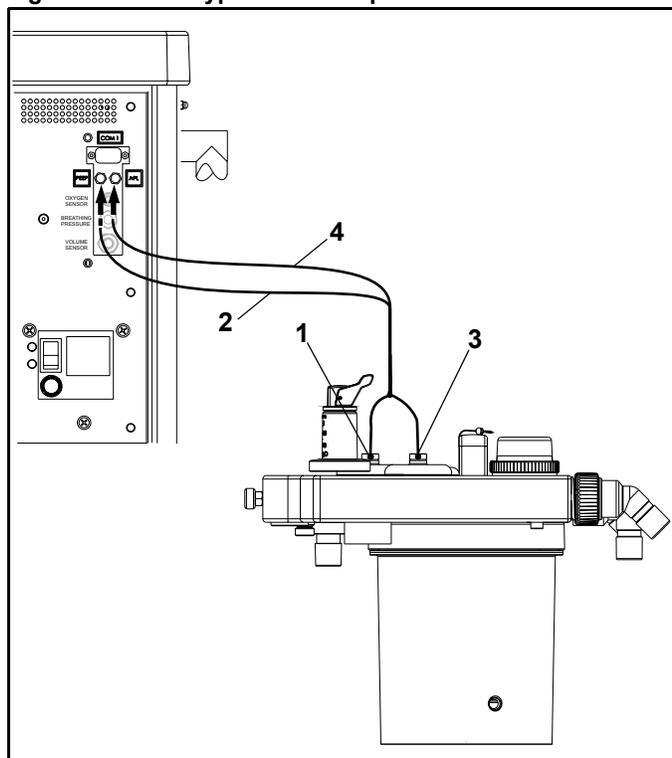

Connecting the Flow Sensor

Push the cable onto the connection port on the flow sensor (1).

Figure 59. Connecting the Flow Sensor

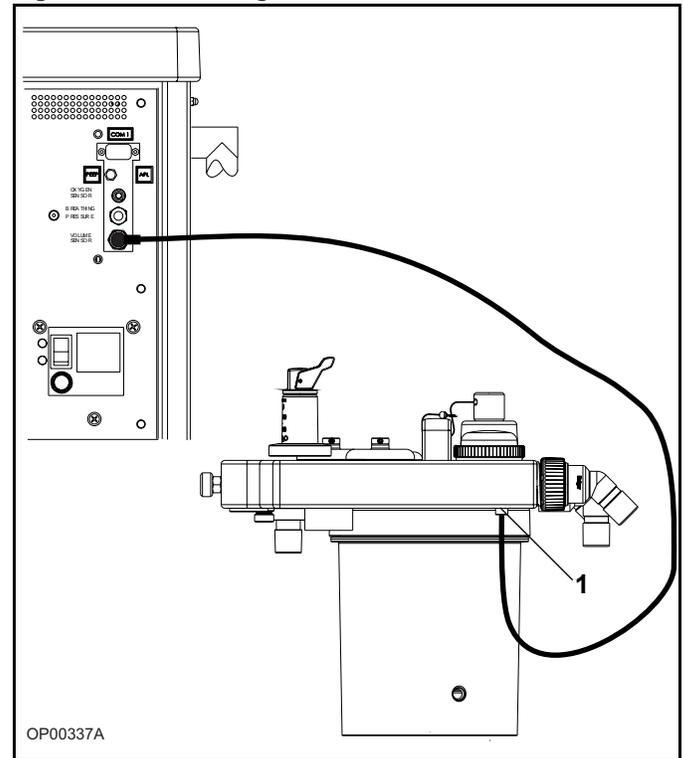

Installing Anesthetic Gas Scavenging Hose to the Compact Breathing System

Connect the transfer hose to the waste gas port of the Compact Breathing System and to the anesthetic gas scavenging line or an anesthetic agent filter.

A second transfer hose is required for the Semi-open compact breathing system.

Figure 60. Installing the Scavenger Transfer Hose

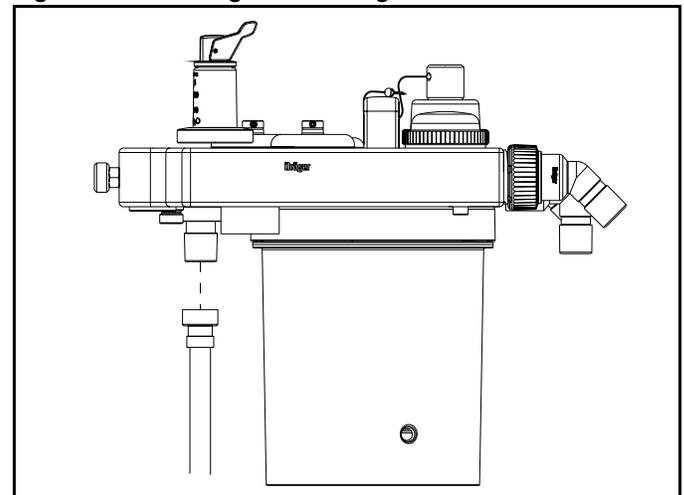

Scavenger System for Fabius GS

Caution: Do not use anesthetic gas scavenging system in combination with extracorporeal oxygenator.

The following numbers in boldface refer to [Figure 61](#).

Output connection (**1**) from the scavenger system to the hospital waste gas removal system.

Connection to scavenger system (**2**) from Fabius GS breathing system.

Flow indicator (**3**). During use, the flow indicator must be between the upper and lower marks on the tube.

Flow adjustment valve (**4**).

Note: Activate hospital vacuum system before using scavenger system.

For more detailed information on the scavenger system, refer to the separate specific Instructions for Use.

For detailed information regarding mounting the scavenger system to the Fabius GS anesthesia workstation, refer to specific instructions provided with the scavenger kit.

Additional Equipment

Prepare additional equipment as specified in the specific Instructions for Use.

Caution: If monitors and other equipment are placed on top of Fabius GS, the risk of tipping over the unit is increased, especially when rolling over thresholds etc.

Remove all monitors and other equipment from the top of the Fabius GS before moving the unit.

Daily and Preuse Checkout Form

Complete the “[Daily and Preuse Checkout Form](#)” in Appendix A.

Figure 61. AGS Scavenger

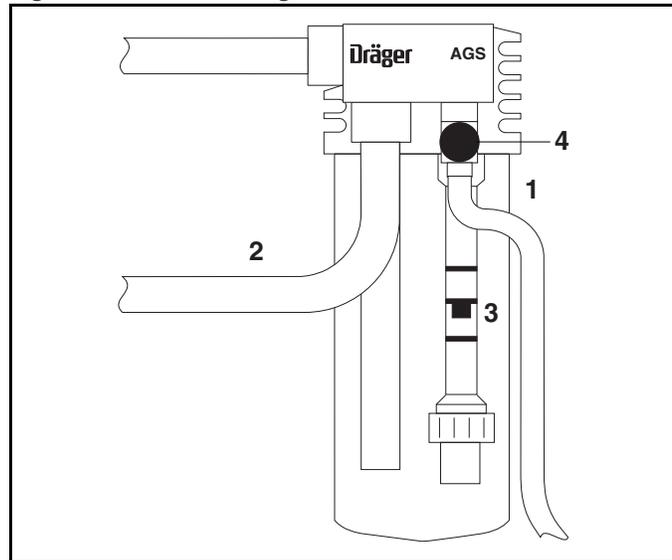

Operation and Shut-down

Contents

Operation	53
Power-Up Screen	53
Power-Up Standby Screen	54
Ventilation Monitor Screen	54
Setting the Vapor	54
O2 Flush	55
Minimum Flow of Anesthesia	55
Nitrogen Wash-out (When Required)	55
Replacing CO2 Absorbent	56
Power Failure Backup	57
Ventilator Fail State	58
Overriding the Ventilator	59
Preparation for Transport or Storage	60
Switch Off the Anesthetic Agent Vaporizer	60
Switching Off the Ventilator	61
Remove the O2 Sensor	61
Switch Off System Power	61
Disconnect the Central Gas Supply	62

Part Number: 4117102-005 Rev: —

Operation

Power-Up Screen

When the SYSTEM POWER switch is turned to the ON position, the Fabius GS performs extensive self-tests on its internal hardware. As these diagnostics are performed, each test and its result appear on the screen. The result, Pass or Fail, indicates the status of the tested component. See [Figure 62](#).

Self-Diagnostic Conclusions

At the end of the self-diagnostics, one of three possible conclusions to the self-tests is posted on the screen ([Figure 62](#)).

FUNCTIONAL

Every component of the monitoring system is in satisfactory operational order. After a brief delay, the Standby screen appears.

CONDITIONALLY FUNCTIONAL

A noncritical fault was detected. The Fabius GS may be used, but call your local Authorized Service Organization or DrägerService (see [“Daily and Preuse Checkout Form”](#) for DrägerService contact information).

Press the rotary knob to continue operation.

NON-FUNCTIONAL

A serious fault was detected and operation of the monitor and ventilator is inhibited. Do not use the machine. Immediately call your local Authorized Service Organization or DrägerService to correct the problem.

Figure 62. Power-Up Screen

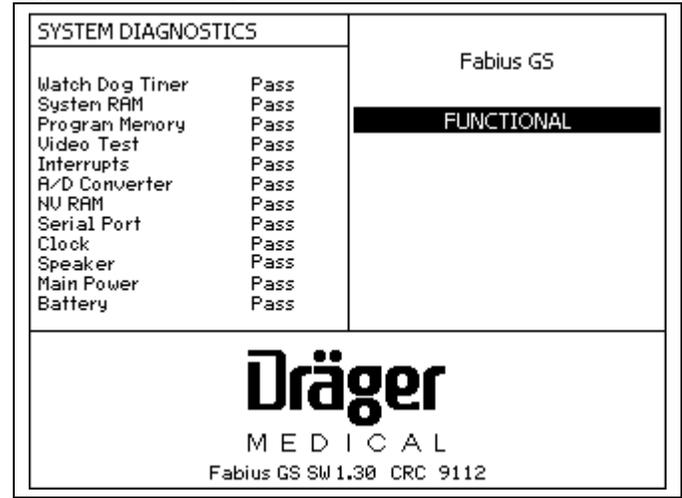

Power-Up Standby Screen

Following a successful power-up, the Standby screen appears (Figure 63) and provides instructions on starting the operation of the Fabius GS.

Figure 63. Power-Up Standby Screen

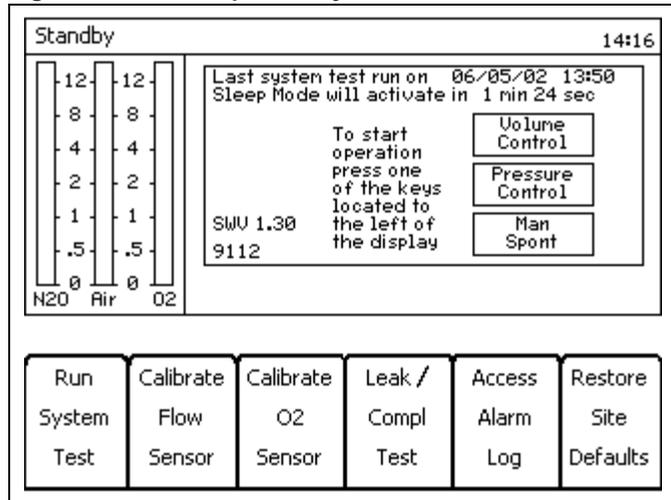

Ventilation Monitor Screen

When the Fabius GS is in use, monitoring information is displayed on the Ventilation Monitor screen.

See "Operating Concept" on page 15 for an explanation of the Ventilation Monitor screen controls and windows.

Figure 64. Ventilation Monitor Screen and System Controls

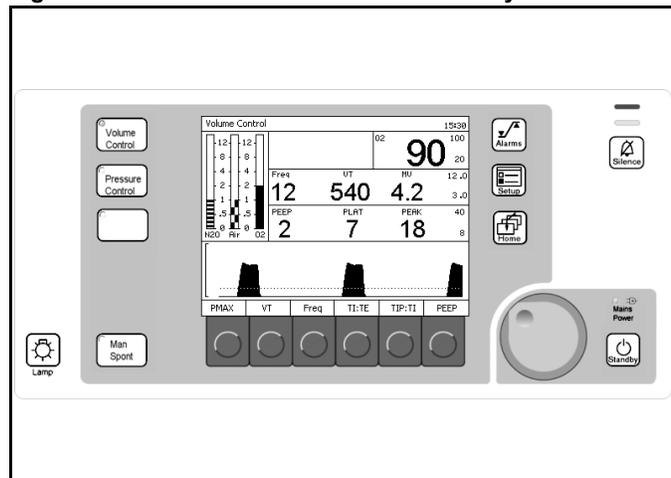

Setting the Vapor

The following numbers in boldface refer to Figure 65.

1. Ensure that the vaporizer is properly seated.
2. Lock the unused Vapor by sliding the lever (1) as far as it will go in the direction of the unused Vapor (in this example, the left hand Vapor is locked).
3. On the Vapor to be used, press and hold down the 0 button (2) and turn the handwheel (3) counter-clockwise to the desired anesthetic agent concentration.
4. Regularly check the filling level on the sight glass. When reaching the minimum mark, fill the Vapor with anesthetic agent.
5. Please refer to the specific Instructions for Use for Dräger Vapor.

Figure 65. Setting the Vapor

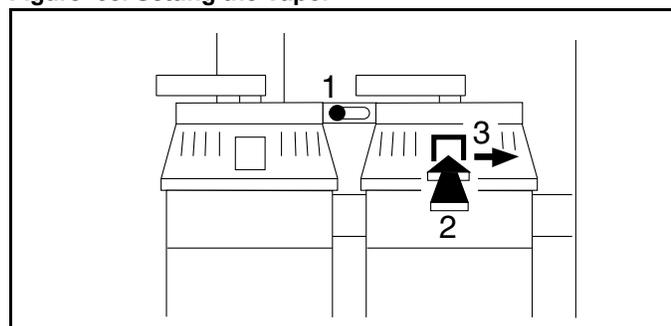

O₂ Flush

1. Press the O₂ Flush button (1 in Figure 66). Additional O₂ flows into the compact breathing system. The flow control elements and the anesthetic agent vaporizer (Vapor) are bypassed.

Note: In Man. Spont. mode, pressure may rise rapidly up to the setting of the APL valve.

Minimum Flow of Anesthesia

When long-term flow of anesthesia is below 0.5 L/min, increased humidity in the ventilator hose is a natural occurrence. Disconnect the ventilator hose from the compact breathing system and clean before and after long term procedures. Use water traps in the expiratory hose. Empty water traps if their water level exceeds the maximum water level limit.

Nitrogen Wash-out (When Required)

During anesthesia induction, air containing about 79% nitrogen (N₂) remains in the compact breathing system (and in the patient's lungs). If the unit will be used for a low-flow anesthesia case, press the O₂ Flush to remove this N₂.

Figure 66. O₂ Flush Button

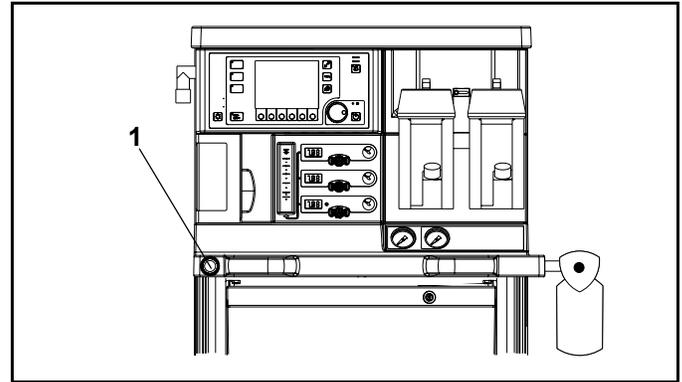

Replacing CO₂ Absorbent

The CO₂ absorbent in the compact breathing system should be replaced when two-thirds of the CO₂ absorbent has changed color. Draeger Medical recommends the use of Dräger sorb 800 Plus. The color change indicates that the CO₂ absorbent can no longer absorb CO₂ (Dräger sorb 800 Plus changes from white to violet).

Do not flush CO₂ absorbent for long periods with dry gas because the CO₂ absorbent will dry out.

When the moisture content falls below a specified minimum level, the following undesirable reactions can occur, regardless of the type of CO₂ absorbent and the anesthetic agent used, e.g. Halothane, Enflurane, Isoflurane, Sevoflurane or Desflurane:

- reduced CO₂ absorption,
- formation of CO,
- absorption and/or decomposition of the inhalation anesthetic agent,
- increased heat generation in the absorber, leading to higher breathing gas temperatures.

These reactions can result in danger to the patient in the form of CO intoxication, insufficient depth of anesthesia and airway burns.

Note: Please refer to the specific Instructions for Use for “Dräger sorb 800 Plus”.

Draeger Medical recommends that absorbent be changed, regardless of color, if the anesthesia machine has been idle for 48 hours or more. Further, Draeger Medical recommends that it be changed at the beginning of the work week.

Warning: Absorbent is caustic and is a strong irritant to the eyes, skin, and respiratory tract. When replacing the absorbent, take care not to spill its caustic contents.

1. Empty the expired CO₂ absorbent from the absorber into an appropriate refuse container.
2. Fill the absorber with fresh CO₂ absorbent.
3. Ensure that no CO₂ absorbent dust/particles have been deposited between the gaskets and sealing surfaces. Such dust and particles can cause leaks in the system.

Dräger recommends the use of Dräger sorb 800 Plus.

Figure 67. Replacing the Absorber Canister

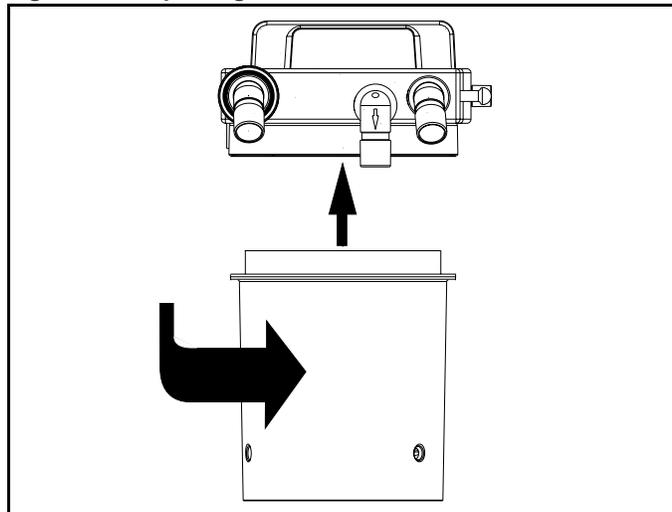

Power Failure Backup

In case of power failure:

- the machine will continue without interruption,
- the "POWER FAIL" caution message will be displayed in the Alarm window,
- the battery symbol () will appear in the status bar,
- and the Mains Power Applied LED turns off.
- At 20% of reserve power, the Advisory message "BATTERY LOW!" is displayed in the alarm window.
- At 10% of reserve power, the Caution message "BATTERY LOW!!" is displayed in the alarm window.

Warning: When the Caution message "BATTERY LOW!!" is displayed in the alarm window, less than nine minutes remain until the electronics shut down. The electronics will remain shut down until AC is restored.

Caution: Never allow the battery to completely discharge. If the battery does discharge completely, recharge immediately.

If the power failure extends beyond the life of the battery or in the event of a power supply failure, the pneumatic functions (APL valve, breathing pressure gauge, S-ORC, cylinder and pipeline gauges, total flow meter, vaporizers, and fresh gas flow control) of the Fabius GS remain functional. Manual or spontaneous ventilation can be maintained.

Ventilator Fail State

If the Fabius GS does not recover from a VENTILATOR FAIL condition,

1. Switch to ManSpont mode by pressing the ManSpont key and confirming the mode change by pressing the rotary knob.
2. Set the APL valve to MAN position.
3. Adjust the APL pressure limit for the desired inspiratory plateau pressure.
4. Press the O2 flush button on the Fabius GS as required to sufficiently inflate the breathing bag.
5. Manually ventilate the patient by squeezing the breathing bag.

Note: In the ventilator fail situation, the ventilator piston assembly position may not be locked. As a result, airway pressure may initially push the piston back to its limit stop, increasing the volume of the breathing bag. It may be necessary to press the O2 flush button again to reinflate the breathing bag.

Overriding the Ventilator

In the unlikely event of a fault in which the ventilator does not recover, and the user cannot switch to manual ventilation mode through the use of the ManSpont key and rotary knob, manual ventilation is still possible.

1. Locate the system power switch on the rear panel.
2. Toggle the system power switch to “off” (Figure 68) and then
3. Toggle the system power switch back to “on” (Figure 69).

The ventilator now performs as in ManSpont mode.

4. Set the APL valve to MAN position.
5. Adjust the APL pressure limit for the desired inspiratory plateau pressure.
6. Press the O2 flush button on the Fabius GS as required to sufficiently inflate the breathing bag.
7. Manually ventilate the patient by squeezing the breathing bag.

Note: After toggling the main power switch, the Fabius GS will perform its diagnostic tests. During the diagnostic tests, manual ventilation is possible. If the diagnostic tests result in “FUNCTIONAL”, the Fabius GS will automatically switch to ManSpont mode if fresh gas flow is detected. Fabius GS respiratory monitoring is available. If the diagnostic tests result in NON-FUNCTIONAL, Manual ventilation is still possible but Fabius GS respiratory monitoring is not available.

Note: In ventilator override situation the ventilator piston assembly position may not be locked, as in ManSpont mode. As a result, airway pressure may initially push the piston back to its limit stop, increasing the volume of the breathing bag. It may be necessary to press the O2 flush button again to reinflate the breathing bag.

8. Contact your local Authorized Service Organization before using the ventilator.

Figure 68. Toggle Power Switch to Off Label

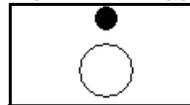
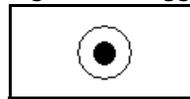

Figure 69. Toggle Power Switch to On Label



Preparation for Transport or Storage

Warning: When moving the anesthesia machine, remove all monitors and equipment from the top shelf, remove the absorber system, and use only the machine handles to push or pull the unit. The anesthesia machine should only be moved by people who are physically capable of handling its weight. Draeger Medical recommends that two people move the anesthesia machine to aid in maneuverability. Exercise special care so that the machine does not tip when moving up or down inclines, around corners, and across thresholds (for example, in door frames and elevators). Do not attempt to pull the machine over any hoses, cords, or other obstacles on the floor.

Switch Off the Anesthetic Agent Vaporizer

(Dräger Vapor)

Turn the handwheel (1 in [Figure 70](#)) to 0 until the button engages.

Figure 70. Closing the Vaporizer

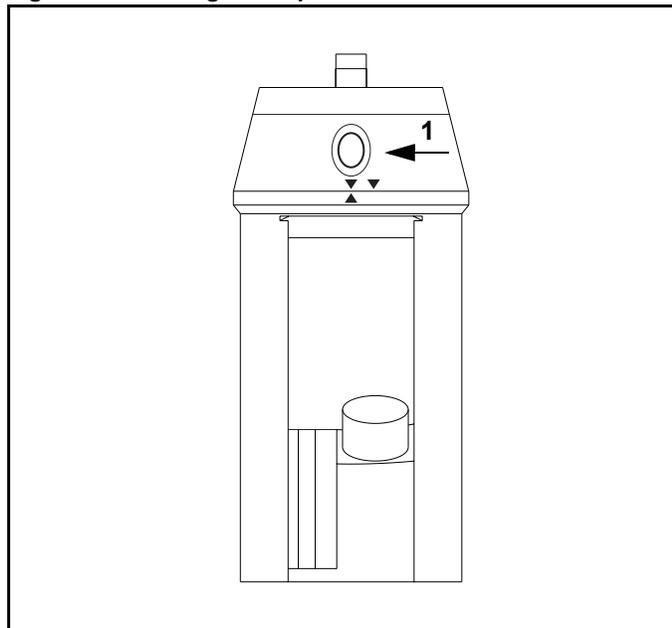

Switching Off the Ventilator

The following numbers in boldface refer to Figure 71.

1. Switch the anesthesia ventilator to standby by pressing the Standby button (1).
2. Confirm by pressing the rotary knob (2). Fabius GS is now in standby mode.

Figure 71. Turning off the Ventilator

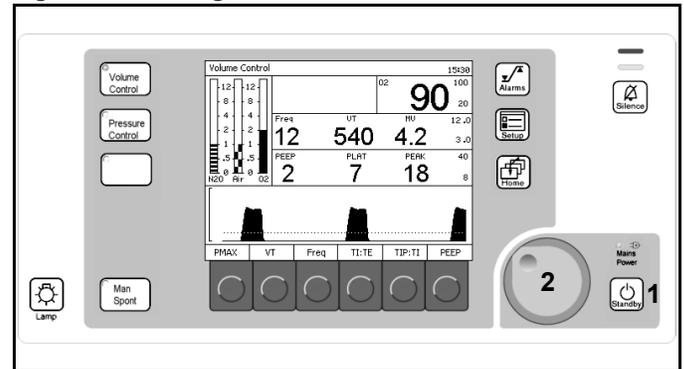

Remove the O₂ Sensor

Remove the O₂ sensor from the inspiratory valve and leave exposed to air. This precaution prolongs the service life of the O₂ sensor.

Switch Off System Power

Switch off the unit using the switch at the back (1) and disconnect the power plug.

Figure 72. Control Unit On/Off Switch

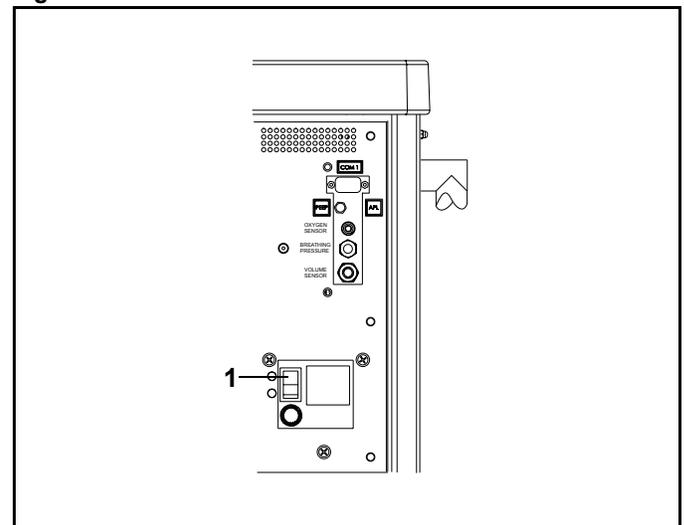

Disconnect the Central Gas Supply

1. Remove all plug-in couplings from the wall terminal units.
2. Close gas cylinders.
3. Press the O2 Flush to depressurize the entire system.

Figure 73. Central Gas Supply

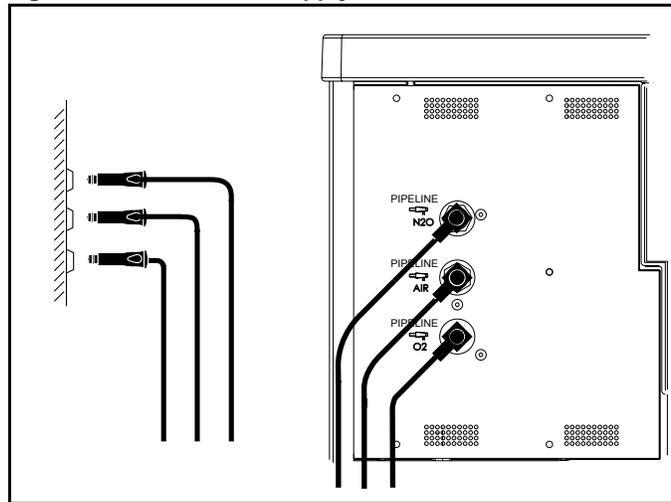

Monitoring

Contents

Overview	65
Alarms	65
Alarm Limits Key	65
Alarm Tones	65
Alarm Text Display Convention	65
Oxygen Monitoring	66
Oxygen Monitoring Overview	66
Oxygen Monitor Window	66
Oxygen Monitor Controls	67
Setting Oxygen Alarm Limits	67
Calibrating the Oxygen Sensor	68
Oxygen Alarm Messages	70
Oxygen Monitoring Problem Resolution	71
Respiratory Volume Monitoring	72
Respiratory Volume Monitoring Overview	72
Respiratory Volume Monitor Display	73
Respiratory Volume Monitor Controls	74
Setting the Minute Volume Alarm Limits	74
Respiratory Volume Alarm Messages	75
Respiratory Volume Monitoring Problem Resolution	76
Breathing Pressure Monitoring	77
Breathing Pressure Monitoring Displays	77
Breathing Pressure Monitor Controls	78
Setting the Pressure and Threshold Alarm Limits	78
Breathing Pressure Alarm Messages	79
Problem Resolution	81

Overview

This chapter describes functions that are specific to oxygen monitoring, respiratory volume monitoring, and breathing pressure monitoring. For information on general monitoring functions, see “Operating Concept” on page 15.

Alarms

Setting Alarm Limits

The Alarm Limits key enables you to set alarm limits for the present procedure.

To set the default alarm limits that take effect at power-up, see “Setting Alarm Limit Defaults” on page 98.

Alarm Limits Key

The Alarm Limits key is shown at 1 in Figure 74.

Displays the Alarm Limits window (1 in Figure 75).

Use the select and confirm process outlined in “Selecting/Setting Monitoring Functions” on page 22 to change the alarm limits on the Alarm Limits window.

Alarm LED Indicators

The Alarm LED indicators are shown at 2 in Figure 74. See “LED Indicators” on page 20 for details.

Alarm Tones

The alarm tones provide an audible alert to the message displays. Each message is assigned a tone or sequence of tones to indicate its degree of urgency.

- Warning (continuous)
- Caution (every 30 seconds)
- Advisory (single signal or no tone for selected advisories only)

Alarm Text Display Convention

- Warnings are followed by three exclamation marks (!!!).
- Cautions are followed by two exclamation marks (!!).
- Advisories are followed by one exclamation mark (!).

Figure 74. Ventilation Monitor Screen and System Controls

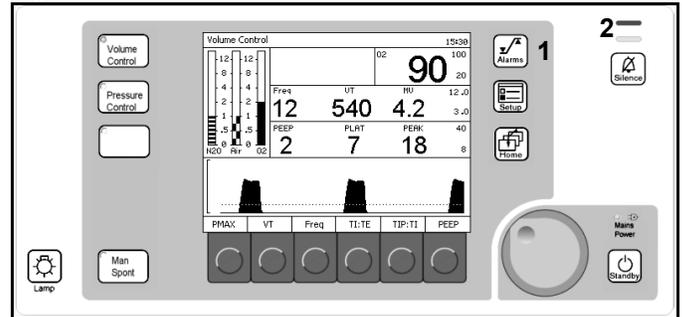
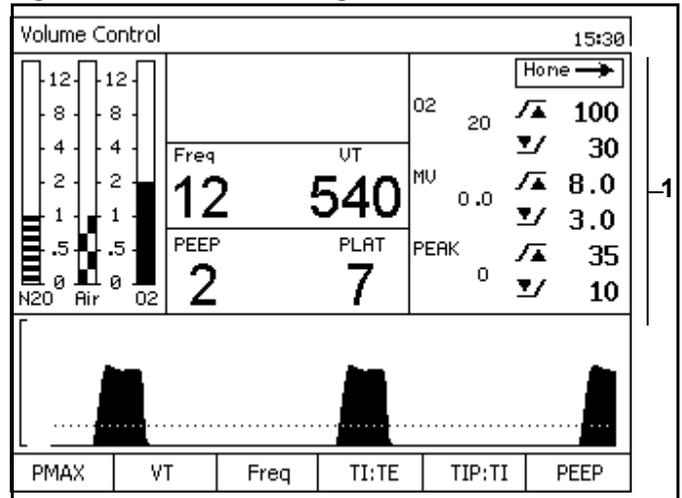

Figure 75. Alarm Limit Configure Menu Window



Oxygen Monitoring

Oxygen Monitoring Overview

Inspiratory oxygen concentration is measured with a dual galvanic cell sensor, which is attached to the inspiratory valve dome. The sensor contains two independent electrochemical cells, or sensor halves. When the sensor is exposed to oxygen, an electrochemical reaction occurs within each cell. The oxygen monitor measures the current produced in each cell, computes an average for the two cells, and translates the average into an oxygen concentration measurement.

Caution: Never remove an oxygen sensor from its housing, except to replace it. If a sensor is removed from its housing, you must do the following before continuing normal operations:

- Reinstall the sensor in the housing.
- Calibrate the sensor.

Note: When the machine is not in use, remove the oxygen sensor assembly from the inspiratory valve dome, and insert the valve dome plug into the dome.

Oxygen Monitor Window

The following numbers in boldface refer to [Figure 76](#).

- **1** - the numerical value for inspiratory oxygen concentration in units of percent (%) between 10% and 100%
- **2** - the high oxygen concentration alarm limit
- **3** - the low oxygen concentration alarm limit

Figure 76. Oxygen Monitor Window

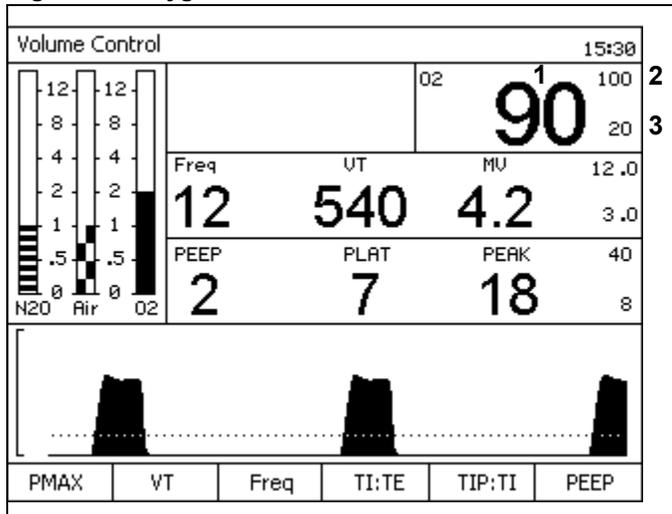

Oxygen Monitor Controls

The following numbers in boldface refer to [Figure 77](#).

You use the Alarm Limits key (1), Setup key (2), and rotary knob (3) to set oxygen concentration alarm limits and calibrate the oxygen sensor.

Figure 77. Monitor Controls

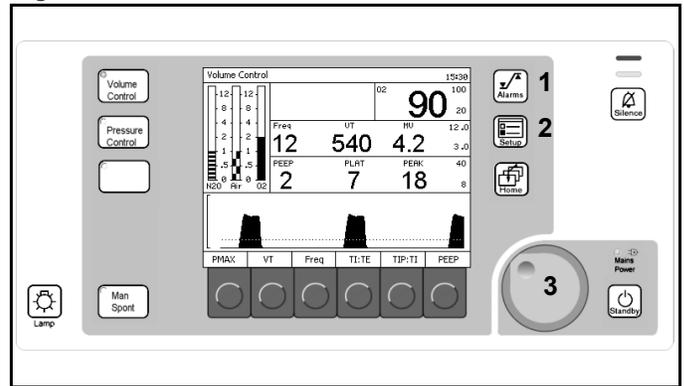

Setting Oxygen Alarm Limits

At power-up, the oxygen high and low alarm limits are automatically set to their default settings (See [“Default Settings” on page 95](#) for more information). You can adjust these limits within specified ranges.

Oxygen Alarm Limits

Oxygen High Limit

The Oxygen High Alarm Limit range is from 19% to 100%. The Oxygen High Limit can not be set less than or equal to the Oxygen Low Limit. **The factory default for Oxygen High Limit is 100%.**

Oxygen Low Limit

The Oxygen Low Alarm Limit range is from 18% to 99%. The Oxygen Low Alarm Limit can not be set equal to or greater than the Oxygen High Limit. **The factory default value for Oxygen Low Limit is 20%.**

Procedure

See [“Alarms” on page 65](#) to change the high or low alarm limit.

Calibrating the Oxygen Sensor

To calibrate the oxygen sensor correctly, make sure it is exposed only to room air during the entire calibration period. The oxygen sensor should be calibrated as part of the daily preoperative setup of the anesthesia equipment.

1. Press the Setup key (1 in [Figure 78](#)).

The Setup screen appears ([Figure 79](#)).

2. Press the soft key under the Calibrate O2 Sensor soft key label (1 in [Figure 79](#)).

The Calibrate O2 Sensor Instruction window replaces the Setup screen soft key labels window ([Figure 80](#)).

After the instructions are followed and the rotary knob is pressed, the present O₂ value is replaced by “CAL” (1 in [Figure 81](#)).

Upon successful completion of the calibration, the O₂ concentration measurement is restored.

If, at the end of the calibration period, the O2 SENSOR FAIL! Advisory message appears in the Alarm window, the calibration was not successful.

An unsuccessful calibration can be caused by several conditions as described in [Table 2 on page 69](#).

Figure 78. Ventilation Monitor Screen and System Controls

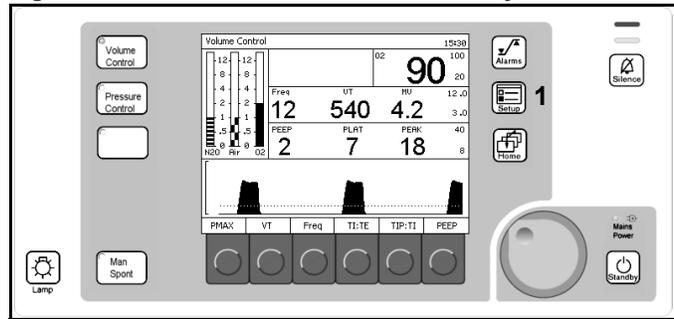

Figure 79. Setup Window

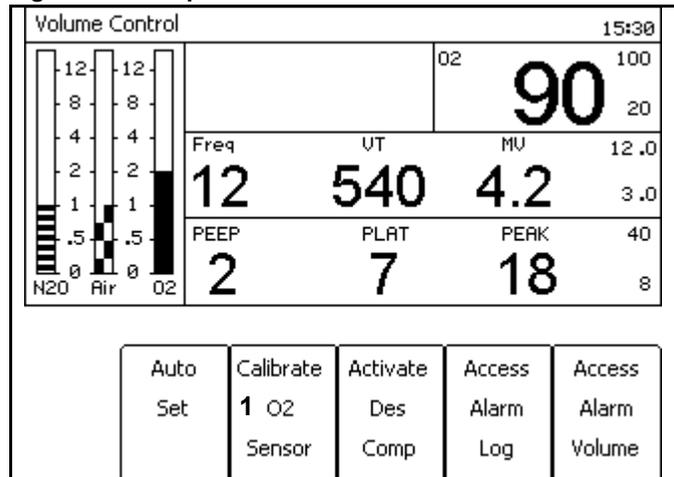

Figure 80. Calibrate O₂ Sensor Instruction Screen

1. Remove O2 sensor and expose to room air for 2 minutes
2. To start O2 Calibration press rotary knob
3. Observe Calibration status in O2 data window
4. Reinsert O2 Sensor after successful Calibration

Figure 81. Calibrate O₂ Sensor in Progress Bar

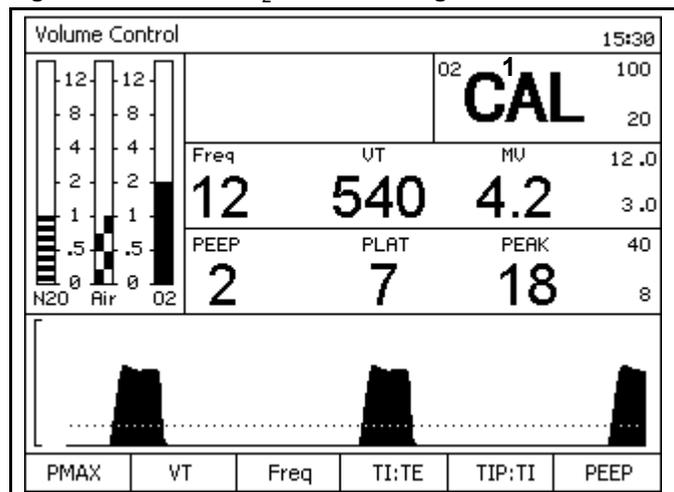

Table 2. Unsuccessful Calibration - Causes and Solutions

Cause	Solution
Sensor was exposed to an excessively lean or excessively rich oxygen calibration mixture.	Make sure that the sensor is exposed to room air for the entire calibration period.
Sensor was exposed to a constantly changing calibration mixture.	Make sure that the sensor is exposed to room air for the entire calibration period.
Sensor did not receive the proper waiting period.	If the sensor capsule was removed from the sensor assembly, a waiting period equal to the time that the capsule spent outside the sensor assembly is necessary prior to calibration. New sensors require a 15-minute waiting period.
Sensor is exhausted.	If the oxygen sensor has decayed beyond its useful service life (see the "Specifications" section of the manual), replace the exhausted sensor with a new sensor and allow the proper waiting period.
Sensor is disconnected.	When the sensor is disconnected or if there is no cell in the housing, the display area is blank, and the message O2 SENSOR FAIL! appears in the Alarm window. If this happens, ensure that the sensor is correctly assembled and recalibrate the oxygen sensor.

Consequences

If the oxygen sensor is improperly calibrated, it can cause inaccurate measurements. When a calibration gas mixture is excessively rich or lean in oxygen, the Fabius GS will not complete an attempted calibration; however, if the calibration gas is rich or lean but is within certain limits, the Fabius GS will complete the calibration. As a result, when displaying sensor measurements, the Fabius GS displays an oxygen percentage either higher or lower than the actual oxygen percentage. Therefore, make sure that the sensor is exposed only to room air during the entire calibration period.

Figure 82 illustrates the relationship between the calibration mixture and the accuracy of oxygen measurement.

A = Displayed O₂ Percentage

B = Actual O₂ Percentage

- 1** = At calibration, sensor exposed to < 21% O₂. Thus, displayed % O₂ will be **higher** than actual O₂.
- 2** = **Correct** calibration of room air (21% O₂) for entire calibration period. Displayed % O₂ = actual % O₂.
- 3** = At calibration, sensor exposed to > 21% O₂. Thus, displayed % O₂ will be **lower** than actual % O₂.

Figure 82. Measurement Error Due to Incorrect Calibration

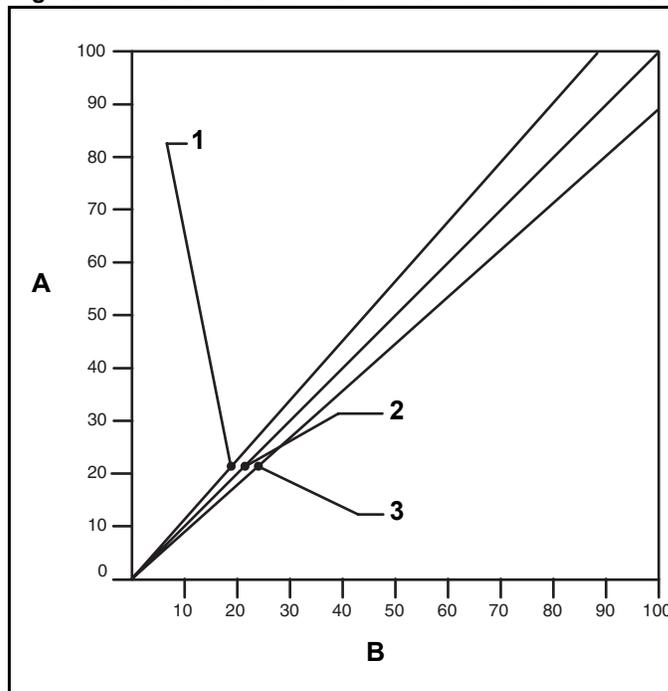

Part Number: 4117102-005 Rev: —

Oxygen Alarm Messages

The following list contains all warning, caution, and advisory alarms associated with oxygen monitoring.

INSP O2 LOW (Warning)

The Warning message INSP O2 LOW!!! appears in the Alarm window and an alarm sounds if the measured inspiratory oxygen concentration falls below the low alarm limit.

O2 SUPPLY LOW (Warning)

The Warning message O2 SUPPLY LOW!!! appears in the Alarm window and an alarm sounds if the oxygen supply drops too low to properly pressurize the fresh gas circuit (below about 20 psi (1.4 bar)).

The red LED indicator in the O₂ area will flash until the O₂ supply is restored.

Under normal operating conditions, the O2 supply channel is pressurized sufficiently to prevent this alarm from occurring. If the O2 supply pressure fails and O2 is not being used by the Fabius GS, the circuit will remain pressurized and the O2 SUPPLY LOW alarm will not annunciate immediately. If pressure is reduced in this circuit by the use of O2, O2 flush, etc., the alarm will annunciate when the internal supply pressure drops below 20 psi (1.4 bar), nominal.

INSP O2 HIGH (Caution)

If the measured inspiratory oxygen concentration exceeds the high alarm limit, the Caution message INSP O2 HIGH!! appears in the Alarm window, and an intermittent audible alarm sounds.

O2 SENSOR FAIL (Advisory)

The Advisory message O2 SENSOR FAIL! appears in the Alarm window when any of the following instances occur:

- O2 sensor has not been correctly calibrated.
- O2 sensor replaced and/or not calibrated.
- O2 sensor used up.
- O2 sensor disconnected.
- Faulty sensor cable.

O2 SENSOR CAL DUE (Advisory)

More than 18 hours have passed since the last sensor calibration.

Oxygen Monitoring Problem Resolution

Table 3. Oxygen Monitoring Problem Resolution

PROBLEM	POSSIBLE CAUSE	REMEDY
Alarm Message O2 SENSOR FAIL! appears in Alarm window.	Sensor needs calibration (Display area remains blank when a reading is expected.)	Perform proper calibration. Remove sensor assembly from breathing circuit. Make sure sensor is exposed to room air only. Calibrate the sensor.
	Hardware malfunction.	Contact your local Authorized Service Organization or DrägerService.
	Faulty sensor housing and cable.	Replace housing/cable assembly.
	Sensor cord is disconnected.	Insert sensor cord connector into the interface panel.
Pressing the Calibrate O2 Sensor soft key does not initiate calibration.	Sensor is disconnected.	Insert sensor cord connector into the interface panel.
	Sensor cord is damaged.	Replace housing/cord assembly.
Pressing Calibrate O2 Sensor soft key initiates calibration, but Oxygen Monitor window is blank at end of calibration period.	Sensor is exposed to incorrect oxygen concentration.	Expose sensor to room air for 21% calibration.
	Sensor exposed to constantly changing calibration mixture.	
	Sensor capsule was removed from housing for a prolonged period.	Allow a waiting period equal to duration of capsule removal.
	New capsule not given proper waiting period.	Allow 15 minute waiting period.
	Exhausted or faulty sensor capsule.	Replace sensor capsule.

Respiratory Volume Monitoring

Respiratory Volume Monitoring Overview

Respiratory volume is measured using thermal anemometry. The flow sensor output is converted into meaningful readings for minute volume, tidal volume, and respiratory rate displays.

Caution: Although the Fabius GS is designed to minimize the effects of ambient radio-frequency interference, the functioning of the respiratory volume monitor may be adversely affected by the operation of electrosurgical equipment or short wave or microwave diathermy equipment in the vicinity.

Note: Sudden, irregular expiratory flow may cause erratic tidal volume and respiratory rate displays. To avoid such erroneous measurements, defer reading the display until a full minute has elapsed after the irregular flow has stopped.

Respiratory Volume Monitor Display

Information about the patient's respiratory volume is presented in the Respiratory Volume Monitor window in the middle of the monitor display as shown in [Figure 83](#). From left to right, measured values are shown for breathing frequency (1), tidal volume (2), and minute volume (3). At the extreme right, in small type, is the minute volume high alarm limit (4) and the minute volume low alarm limit (5).

The following numbers in boldface refer to [Figure 83](#).

- **Frequency (Freq) (1)**
Shows the number of breaths during the previous minute of respiration.
Readings appear after two breaths.
The numeric data is displayed in units of Breaths Per Minute (bpm).
The display range is from 2 bpm to 99 bpm.
- **Tidal Volume Measurement (VT) (2)**
Displays the expired volume for each breath.
If the monitor does not detect a valid breath within 30 seconds in an automatic ventilation mode or within 60 seconds in ManSpont mode, the display area goes blank.
The numeric data is displayed in units of milliliters (mL).
The display range is from 0 mL to 1500 mL.
- **Minute Volume Measurement (MV) (3)**
Continuously displays the volume of exhaled gas accumulated during the previous minute of respiration.
The numeric data is displayed in units of liters/minute (L/min).
The display range is from 0.1 L/min to 99.0 L/min.
- **Minute Volume Alarm High Limit (4)**
Indicates the volume above which an alarm condition occurs.
The numeric data is displayed in units of liters/minute (L/min).
- **Minute Volume Alarm Low Limit (5)**
Indicates the volume below which an alarm condition occurs.
The numeric data is displayed in units of liters/minute (L/min).

Figure 83. Monitor Display

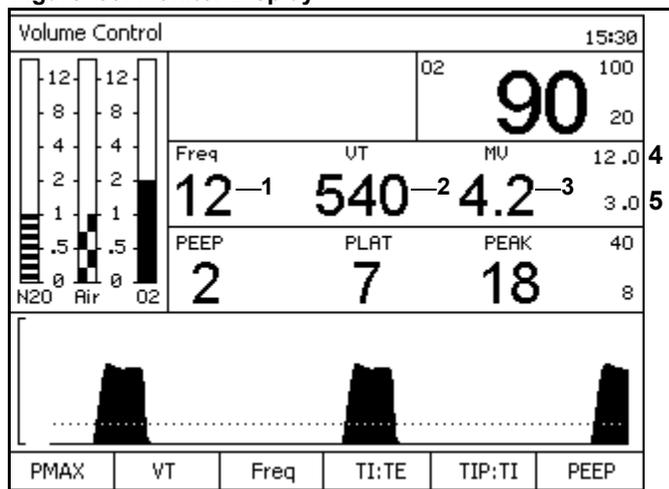

Respiratory Volume Monitor Controls

The following numbers in boldface refer to [Figure 84](#).

You can use the Alarm Limits key (**1**), the Standby key (**2**), and the rotary knob (**3**) to set the high and low respiratory volume alarm limits.

While the ventilator is on, apnea volume alarms are generated at 15 seconds (Caution) and 30 seconds (Warning) if the respiratory volume monitor does not sense a valid breath. While the ventilator is off and the system is in ManSpont mode, these alarms are generated at 30 seconds (Caution) and 60 seconds (Warning).

The Fabius GS's volume alarms are automatically enabled when the ventilator is switched from Standby to a ventilation mode.

Setting the Minute Volume Alarm Limits

If the minute volume falls below the minute volume low alarm limit or above the minute volume high limit, an alarm condition occurs.

Minute Volume High Limit

The Minute Volume High Limit range is from 0.1 L/min. to 20.0 L/min.

Factory default value: 12.0 L/min.

Minute Volume Low Limit

The Minute Volume Low Limit range is from 0.0 L/min. to 19.9 L/min.

Factory default value: 3.0 L/min.

Procedure

See [“Alarms” on page 65](#) to change the low alarm limit.

Figure 84. Respiratory Volume Monitor Controls

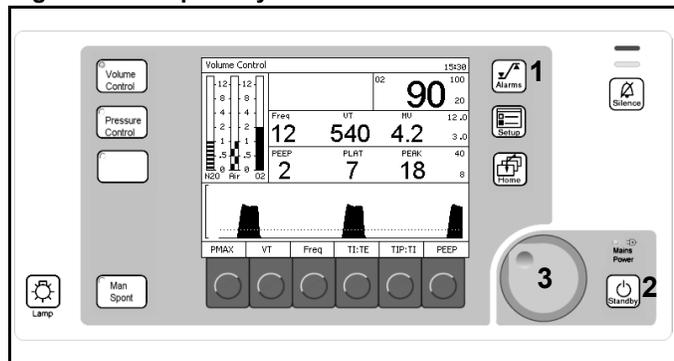

Respiratory Volume Alarm Messages

The following list contains all warning, caution, and advisory alarms associated with respiratory volume monitoring.

APNEA VOLUME (Warning/Caution)

The Fabius GS continuously monitors the expiratory flow in the patient breathing system. By processing the expiratory flow pattern, the monitor can determine whether a valid breath has occurred. A valid breath has a tidal volume of 20 mL or greater.

When the ventilator is on:

- If 15 seconds pass and a valid breath is not detected, the Caution message APNEA VOLUME!! appears in the Alarm window, and an intermittent audible alarm sounds.
- If an additional 15 seconds pass (30 seconds total) and a valid breath is not detected, the Caution message APNEA VOLUME!! is upgraded to a Warning in the Alarm window, and a continuously repeating audible alarm sounds.

During apneic conditions, the respiratory volume measurements disappear after 30 seconds. When a valid breath is detected, alarm annunciation ceases and a tidal volume measurement appears in the display window.

When the system is in ManSpont Mode:

- The Caution condition does not occur until 30 seconds have elapsed without a valid breath.
- The Warning condition does not occur until 60 seconds have elapsed without a valid breath.

During apneic conditions, the respiratory volume measurements disappear after 60 seconds. When a valid breath is detected, alarm annunciation ceases and a tidal volume measurement appears in the display window.

EXP PORT LEAKAGE (Caution)

Expiratory volume during inspiration is greater than 15 mL.

MINUTE VOLUME HIGH (Caution)

Whenever the Fabius GS measures a minute volume higher than the high minute volume alarm limit, the Caution message MINUTE VOLUME HIGH!! appears in the Alarm window, and an intermittent audible alarm sounds.

MINUTE VOLUME LOW (Caution)

Whenever the Fabius GS measures a minute volume less than the low minute volume alarm limit, the Caution message MINUTE VOLUME LOW!! appears in the Alarm window, and an intermittent audible alarm sounds.

FLOW SENSOR CAL DUE (Advisory)

The FLOW SENSOR CAL DUE! advisory message appears in the Alarm window if it has been longer than 18 hours since the flow sensor has been calibrated.

FLOW SENSOR FAIL (Advisory)

The FLOW SENSOR FAIL! advisory message appears in the Alarm window if the sensor cable is not properly connected to the interface panel, if there is an internal sensor fault.

VOLUME ALARMS OFF (Advisory)

Volume alarms disabled by the operator when in ManSpont mode.

Respiratory Volume Monitoring Problem Resolution

Table 4. Respiratory Volume Monitoring Problem Resolution

PROBLEM	POSSIBLE CAUSE	REMEDY
Blank display area	Two breaths have not elapsed (for minute volume and respiratory rate) since respiration began.	Wait for two breaths to read display.
	Apnea condition	Correct apnea condition. Ensure sensor is properly connected to the expiratory valve.
Blank display area, FLOW SENSOR FAIL! alarm message in Alarm window	Sensor cable is disconnected.	Reconnect sensor cable to sensor at breathing system.
	Sensor fault	Replace sensor assembly.
Inaccurate data displayed	Flow sensor signal drift	Calibrate the sensor.
	Desflurane compensation setting not consistent with actual agent delivered	Activate or deactivate "Des Comp" as appropriate.
	External agent analyzer providing inaccurate data through the communications port.	Check agent analyzer. Check communications cable. Disconnect analyzer from the Fabius GS and set "Des Comp" appropriately.

Part Number: 4117102-005 Rev: —

Breathing Pressure Monitoring

Breathing Pressure Monitoring Displays

Information about the patient's breathing pressure is presented in the Breathing Pressure Monitor Window (1 in Figure 85) and in the Breathing Pressure Trace Window (2 in Figure 85).

The Breathing Pressure Monitor window contains breathing pressure measurements expressed in units of cmH₂O as well as the pressure high and pressure threshold alarm limits. The measurement units are selected via the Configuration screen (see "Configuration" on page 101).

Note: The Fabius GS can be configured by your Local Authorized Service Organization to display mean pressure (MEAN) instead of plateau pressure (PLAT).

The following numbers in boldface refer to Figure 86.

- **1 - PEEP (Positive End Expiratory Pressure)**
The breathing pressure at the end of exhalation. The numeric data display range is from 0 to 30.
- **2 - PLAT (Plateau) Breathing Pressure**
The breathing pressure at the end of inspiration. The numeric data display range is from 0 to 80.
- **2 - MEAN Breathing Pressure**
The average of all the instantaneous pressure values recorded during each breath. The numeric data display range is from 0 to 50.
- **3 - PEAK Breathing Pressure**
The highest instantaneous pressure value for each breath. The numeric data display range is from 0 to 80.
- **4 - Pressure High Alarm Limit**
- **5 - Pressure Threshold Alarm Limit**
- **6 - Breathing Pressure Trace Window**
This large window displays a breathing pressure trace, or waveform.
- **7 - Breathing Pressure Threshold Limit Line**
- **8 - Breathing Pressure Minimum and Maximum Trace Scale Limits Indicator**

Figure 85. Breathing Pressure Monitoring Displays

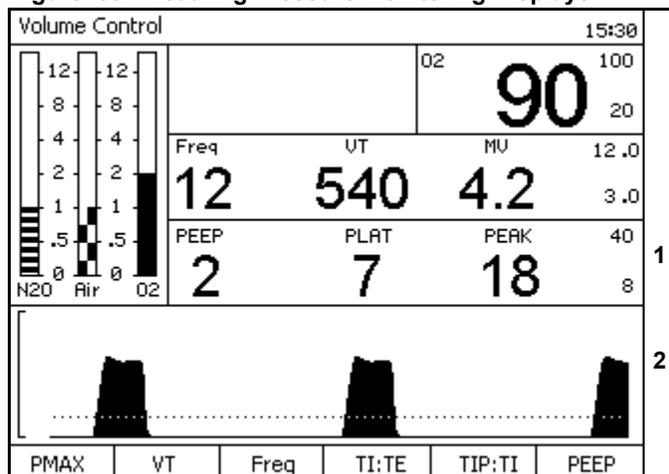
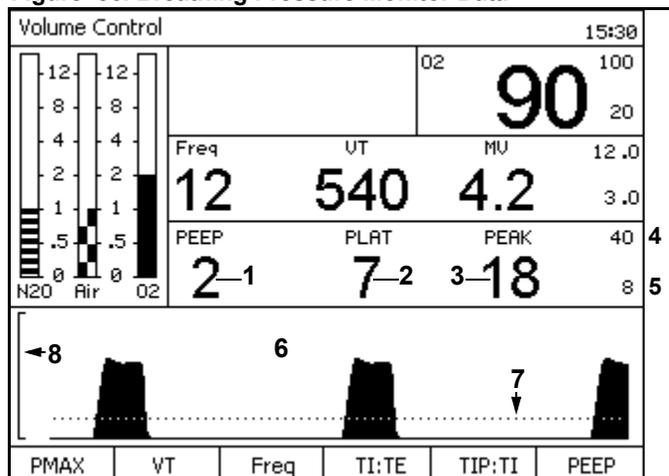

Figure 86. Breathing Pressure Monitor Data



Breathing Pressure Monitor Controls

The following numbers in boldface refer to [Figure 87](#).

The Alarm Limits key (**1**) and the rotary knob (**2**) enable you to set breathing pressure alarm limits.

Figure 87. Breathing Pressure Monitor Controls

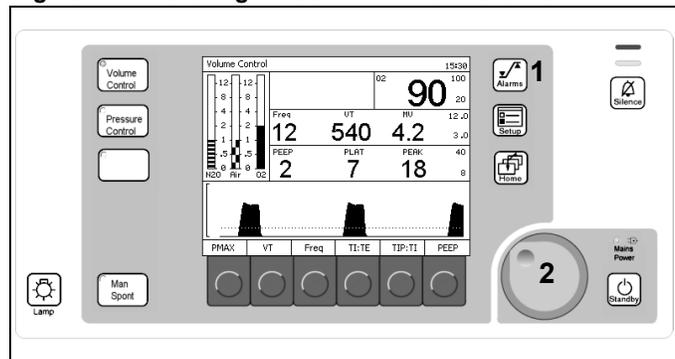

Setting the Pressure and Threshold Alarm Limits

At power-up and when you press the Restore Default Settings key on the Standby screen, the breathing pressure high and pressure threshold alarm limits are automatically set to their default settings. You can adjust these limits within specified ranges.

Pressure Threshold Alarm Limit

The Pressure Threshold Limit range is from 5 to 30 cmH₂O.

Factory default value: 8 cmH₂O.

The pressure threshold alarm limit defines the level below which an apneic alarm condition exists. When the patient's breathing pressure falls below the threshold limit for 15 seconds, a message appears in the Alarm window and an audible alarm sounds.

Note: The pressure threshold alarm limit should be as close as possible to the sensed peak pressure without exceeding it, approximately 6 cmH₂O below the peak pressure.

Procedure

See [“Alarms” on page 65](#) to change the pressure high alarm limit.

Breathing Pressure Alarm Messages

The following list contains all warning, caution and advisory alarms associated with breathing pressure monitoring.

PRES APNEA ALARM OFF

The apnea pressure alarm is disabled.

APNEA PRESSURE (Warning/Caution)

When the ventilator is on:

If the measured breathing pressure does not cross the pressure threshold alarm limit for more than 15 seconds, the Caution message APNEA PRESSURE!! appears in the Alarm window and an intermittent audible alarm sounds.

If the breathing pressure does not cross the pressure threshold for an additional 15 seconds (30 seconds total), the Caution message APNEA PRESSURE!! is upgraded to a Warning in the Alarm window (APNEA PRESSURE!!!), and a continuously repeating audible alarm sounds.

When the system is in ManSpont Mode:

The APNEA PRESSURE alarm is automatically deactivated. The APNEA PRESSURE alarm can be activated. When it is activated in ManSpont mode, the Caution occurs after 30 seconds, and the Warning occurs after 60 seconds.

CONTINUOUS PRESSURE (Warning)

If the measured breathing pressure remains above the pressure threshold alarm limit for more than 15 seconds, the breathing pressure display area is cleared, the Warning message CONTINUOUS PRESSURE!!! appears in the Alarm window, and a continuous audible alarm sounds.

When the measured breathing pressure drops below the pressure threshold alarm limit, alarm annunciation ceases.

AIRWAY PRESSURE HIGH (Warning)

If the measured breathing pressure exceeds the high pressure limit, the Warning message AIRWAY PRESSURE HIGH!!! appears in the Alarm window and a continuously repeating audible alarm sounds.

This alarm condition is cleared when the measured breathing pressure drops below the high pressure alarm limit. However, the alarm message is extended for 10 seconds to allow for a momentary high pressure condition.

PRESSURE NEGATIVE (Warning)

If the measured breathing pressure falls below $-5 \text{ cmH}_2\text{O}$ or mean pressure falls below $-2 \text{ cmH}_2\text{O}$, the Warning message PRESSURE NEGATIVE!!! appears in the Alarm window and a continuously repeating audible alarm sounds.

This alarm condition is cleared when the sensed pressure rises above $-5 \text{ cmH}_2\text{O}$ or above a mean pressure of $-2 \text{ cmH}_2\text{O}$. However, the alarm message is extended for 10 seconds to allow the recognition of a momentary subatmospheric pressure condition.

EXP PRESSURE HIGH (Caution)During Volume or Pressure Ventilation (Caution)

Any time that the monitor measures a PEEP of $4 \text{ cmH}_2\text{O}$ over the PEEP setting, the Caution message EXP PRESSURE HIGH!! appears in the Alarm window and an intermittent audible alarm sounds.

PEEP HIGH (Advisory)During ManSpont Mode (Advisory)

Alarm annunciation occurs when the measured PEEP is greater than $4 \text{ cmH}_2\text{O}$.

INSP PRES NOT REACH (Advisory)

Any time that PINSP pressure is not reached in Pressure mode, the Advisory message INSP PRES NOT REACH! appears in the Alarm window.

PRESSURE SENSOR FAIL (Advisory)

If the Fabius GS detects a faulty sensor, the Advisory message PRESSURE SENSOR FAIL! appears in the Alarm window. If this happens, call your local Authorized Service Organization or DrägerService (see [“Daily and Preuse Checkout Form”](#) for DrägerService contact information).

PRESSURE LIMITING (Advisory)

Any time that the monitor detects pressure greater than or equal to the P_{MAX} setting, Advisory message PRESSURE LIMITING! appears in the Alarm window. This advisory can only occur when the ventilator is in Volume Control mode.

PRES THRESHOLD LOW (Advisory)

The Advisory message PRES THRESHOLD LOW appears in the Alarm window any time the sensed peak pressure exceeds the threshold pressure alarm limit by more than $6 \text{ cmH}_2\text{O}$ at threshold pressure alarm limit settings of $5\text{--}20 \text{ cmH}_2\text{O}$, or by more than

8 cmH₂O at threshold pressure alarm limit settings of 21–29 cmH₂O. Setting the threshold pressure alarm limit at 30 cmH₂O disables the PRES THRESHOLD LOW advisory.

Problem Resolution

Table 5. Breathing Pressure Monitoring Problem Resolution

PROBLEM	POSSIBLE CAUSE	REMEDY
No pressure readout in display area during ventilation	Pilot line not connected.	Make sure pilot line is properly connected.
	Pilot line blocked or kinked.	Make sure that lumen of pilot line is free of obstructions.
Erratic readings	Condensation accumulation in pilot line.	Drain and reconnect pilot line.

Setup Window (Used During Operation)

Contents

- Overview 85
- Setup Window Access 85
- Auto Set 86
- Calibrate O2 Sensor 86
- Activate Des Comp 87
- Access Alarm Log 88
- Access Alarm Volume 88
- Window Deactivation 88

Part Number: 4117102-005 Rev: —

Overview

This chapter describes the monitoring and ventilation functions available in the Setup window, which can be used in Volume Control, Pressure Control, and ManSpont mode.

The Setup window enables you to

- perform ventilation functions and
- view and change monitoring settings for the current operation.

Note: To set default monitoring settings to be used at the power-up of each operation, see “Standby Setup Screen” on page 95.

Setup Window Access

Press the Setup key (1 in Figure 88) while the ventilator is in Volume Control, Pressure Control, or ManSpont ventilation mode.

The Setup window (1 in Figure 89) replaces the Waveform area and the soft key labels (2 and 3 in Figure 88).

Figure 88. Ventilation Monitor Screen and System Controls

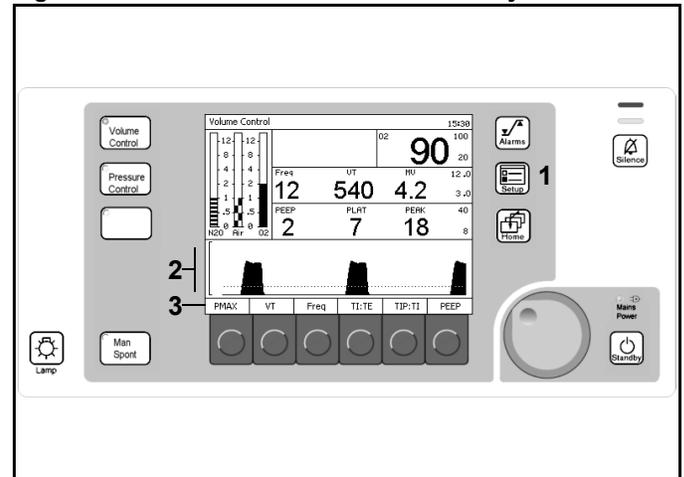
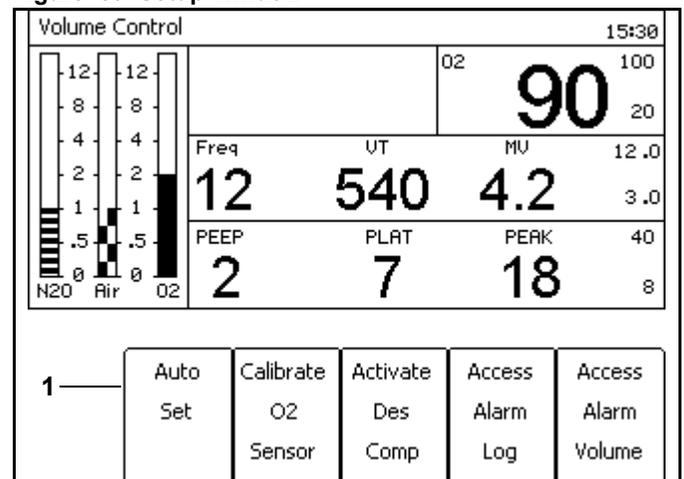

Figure 89. Setup Window



The following soft key labels appear in the Setup window:

- Auto Set
- Calibrate O2 Sensor
- Activate Des Comp
- Access Alarm Log
- Access Alarm Volume

Auto Set

Press the Auto Set soft key.

The breathing pressure threshold is set to 4 cmH₂O below the current Peak pressure data value.

Note: The threshold setting may not be less than 5 cmH₂O or greater than 30 cmH₂O.

Note: In the absence of a current Peak pressure data value, pressing the softkey will have no effect.

Calibrate O₂ Sensor

1. Press the Calibrate O₂ Sensor soft key.

The Calibrate O₂ Sensor Instruction window (Figure 90) replaces the Setup window.

2. Follow the instructions and press the rotary knob.

The present O₂ value is replaced by "CAL" (1 in Figure 91).

Upon completion of the calibration, the O₂ concentration measurement appears.

If the O₂ sensor can not be calibrated, replace the O₂ capsule in the O₂ sensor housing (see "Inserting A New O₂ Sensor Capsule" on page 46).

If the O₂ sensor still can not be calibrated, call your local Authorized Service Organization or DrägerService (see "Daily and Preuse Checkout Form" for DrägerService contact information).

Figure 90. Calibrate O₂ Sensor Instruction Screen

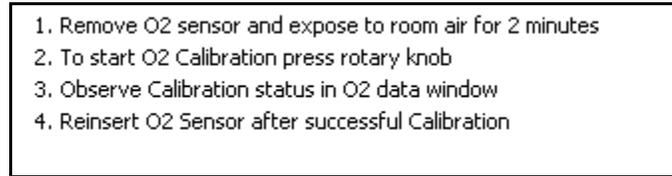
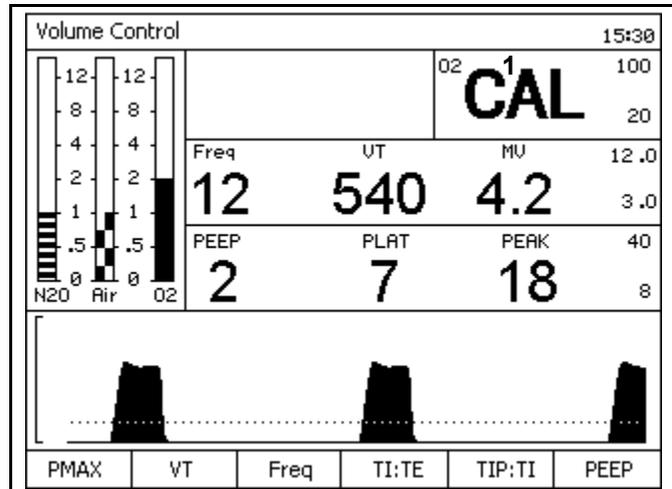

Figure 91. Calibrate O₂ Sensor in Progress Bar



Activate Des Comp

Press the Activate Des Comp soft key.

Desflurane compensation is Activated.

When the Activate Des Comp soft key is pressed, its soft key label changes from “Activate Des Comp” to “Deactivate Des Comp” (1 in Figure 92). “Des ON” appears at the top of the Setup window (2 in Figure 92).

The Desflurane compensation state will not change when you restore site defaults or run system diagnostics.

Note: Desflurane has characteristics that affect the sensitivity of the Fabius GS flow sensor. To help assure that the volume measurements from the monitor are accurate, select "ACTIVATE DES COMP" when Desflurane is used in the breathing circuit. The Fabius GS will automatically compensate for the change in flow measurement characteristics caused by the use of Desflurane.

Caution: Ensure that Desflurane compensation is only activated whenever Desflurane is used. Failure to activate when Desflurane is used will affect measured volume accuracy. Activating when Desflurane is not used will affect measured volume accuracy.

Caution: The Fabius GS will automatically compensate for Desflurane when agent concentration data is available through communication with an external agent analyzer. Inaccurate data from the analyzer may affect measured volume accuracy.

Note: If Desflurane concentration data is communicated to the Fabius GS by an external agent analyzer, the Fabius GS will automatically perform the corresponding flow compensation. In this case, the communicated data always overrides the functionality of the Desflurane compensation softkey.

Figure 92. Setup Des Comp Activated

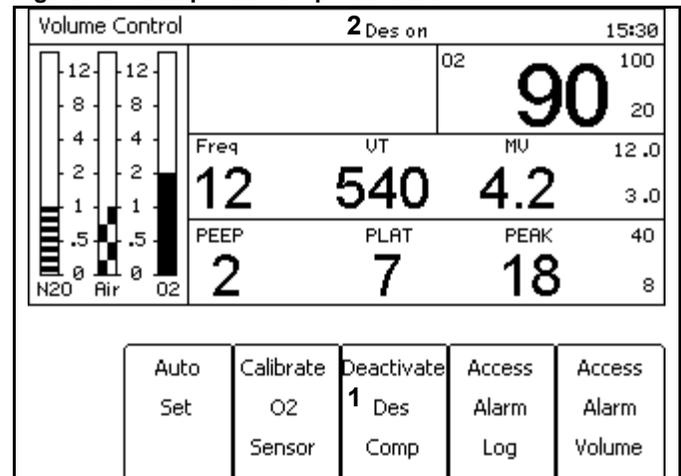

Access Alarm Log

Press the Access Alarm Log soft key.

The alarm log (Figure 93) replaces the Setup window.

Turn the rotary knob to scroll down the list of alarm messages.

Note: If “Clear Alarm Log” is selected and confirmed, all alarm messages in the Alarm Log are deleted.

Figure 93. Setup Alarm Log

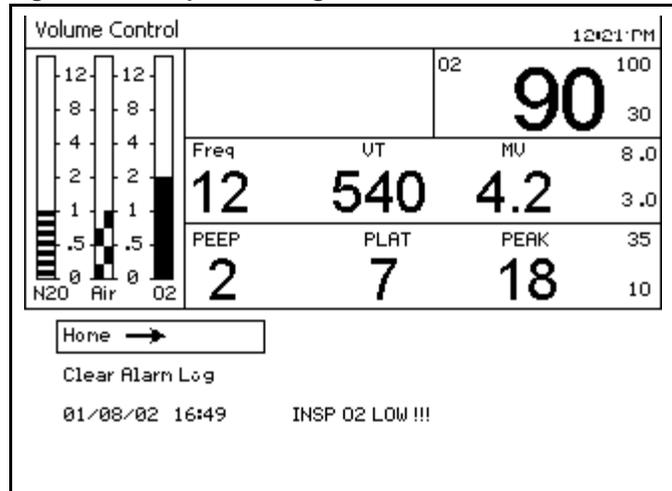

Access Alarm Volume

1. Press the Access Alarm Volume soft key.

The Alarm Volume Setting window (Figure 94) replaces the Setup window.

2. Select and confirm a new alarm volume value.

The new alarm volume value is saved and the Access Alarm Volume Setting window disappears.

Note: The value “1” is the minimum and the value of “10” is the maximum.

Figure 94. Setup Alarm Volume

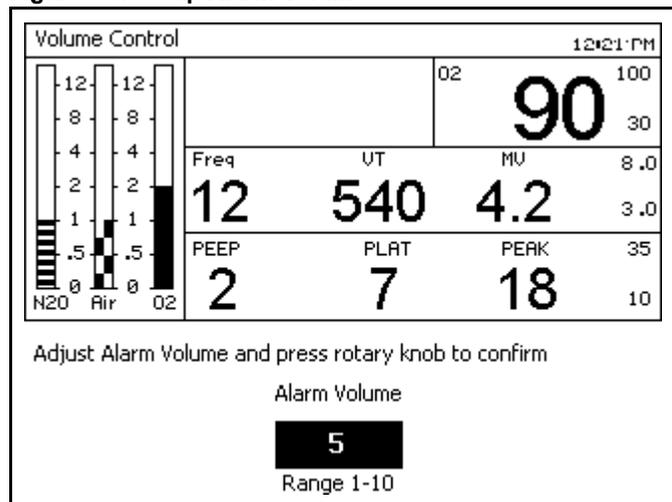

Window Deactivation

Once the Setup window is activated, if no rotary knob activity occurs within 15 seconds, the Setup window is deactivated and the Waveform window is activated. Another way to deactivate the Setup window and activate the Waveform window is to press the Home key.

Standby Mode Functions

Contents

- Overview 91
- Standby Screen 91
 - Access 91
 - Sleep Mode 92
 - Run System Test 92
 - Calibrate Flow Sensor 92
 - Calibrate O2 Sensor 93
 - Leak / Compliance Test 93
 - Access Alarm Log 94
 - Restore Site Defaults 94
- Standby Setup Screen 95
 - Default Settings 95
 - Configuration 101

Part Number: 4117102-005 Rev: —

Overview

This chapter describes the functions that are made available in Standby mode.

Standby Screen

Access

1. Press the Standby key.

The Standby Confirmation Message and Gas Flow Control Valve Shut Off Message window (1 in Figure 95) replaces the Waveform window.

The LED associated with the Standby key starts blinking. It remains blinking until Standby is confirmed by pressing the rotary knob.

Note: If confirmation does not occur within 15 seconds, the Standby Confirmation Message and Gas Flow Control Valve Shut Off Message window are deactivated and the Waveform window is activated. The Ventilator will not be switched to Standby mode.

2. Confirm.

The Standby screen (Figure 96) replaces the previous screen.

After the Standby status is confirmed,

- The Standby key's LED is switched from blinking to constantly on, and the ventilator is switched to Standby mode.
- If fresh gas flow is detected, then the flows were not shut off before activating Standby mode and the "Gas still flowing!" alarm message will appear in the alarm window (Figure 96). Once all gas flow control valves are shut off, the flow detection alarm message disappears (Figure 97).

Figure 95. Standby Confirmation Message and Gas Flow Control Valve Shut Off Message Window

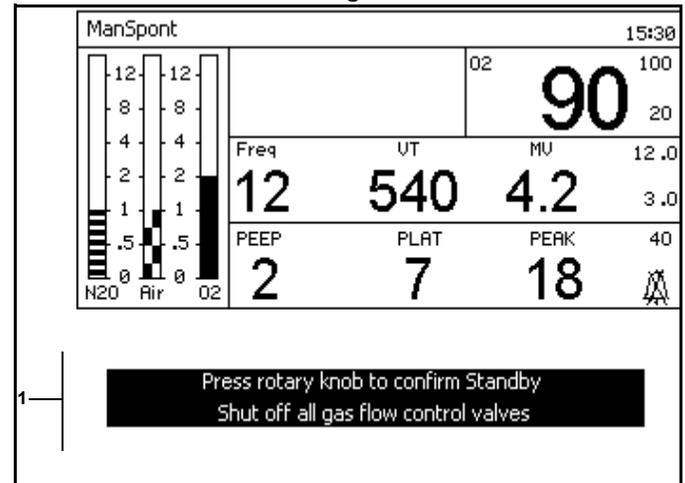

Figure 96. Standby Screen

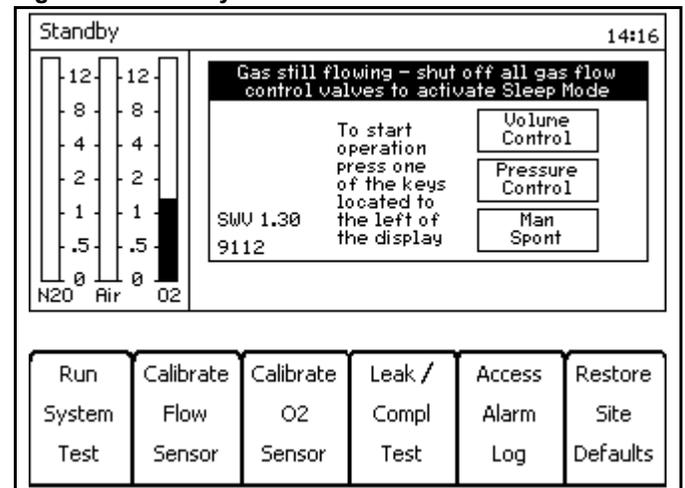
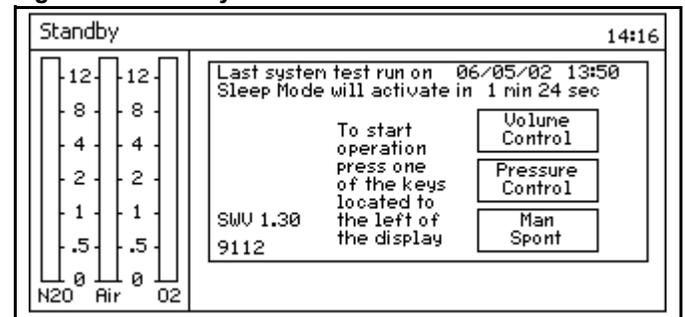

Figure 97. Standby Screen



Sleep Mode

If 5 minutes elapse in Standby mode with no user input, SLEEP mode is activated (Figure 98). The Ventilator monitor screen is replaced by the screen saver. The Screen Saver displays a message that provides instructions on how to activate Standby mode.

Figure 98. Sleep Mode Screen



Run System Test

Press the Run System Test soft key.

The system diagnostics is performed (Figure 99).

After successful completion, the system switches to the Standby screen.

Figure 99. Diagnostics Screen

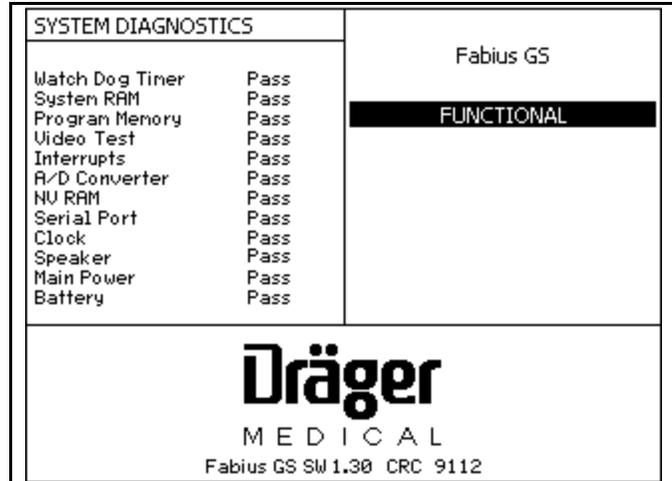

Calibrate Flow Sensor

1. Press the Calibrate Flow Sensor soft key.
The Calibrate Flow Sensor Instruction window replaces the Standby screen soft key labels (Figure 100).

2. Follow the instructions.
The Calibrate Flow Sensor in Progress bar replaces the instruction window (Figure 101).

3. Upon completion of the calibration, the “Flow Sensor Calibration completed” message (Figure 102) or the “Flow Sensor Calibration FAILED” message (Figure 103 on page 92) appears.

Figure 100. Calibrate Flow Sensor Instruction Screen

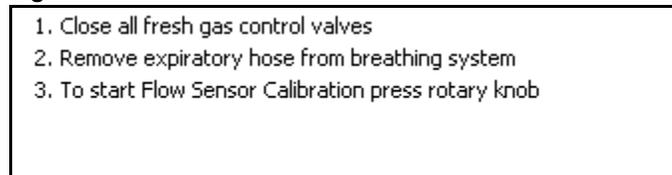

Figure 101. Calibrate Flow Sensor in Progress Bar

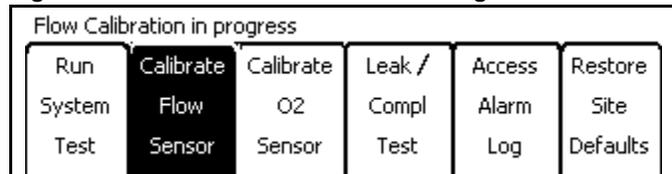

Figure 102. Calibrate Flow Sensor Completed Bar

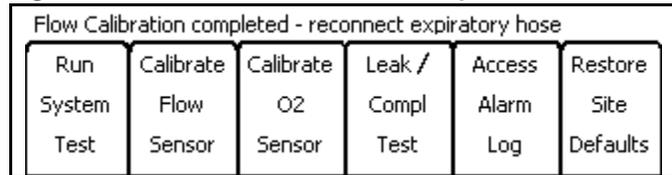
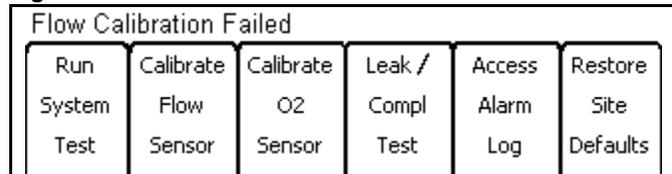

Figure 103. Calibrate Flow Sensor Failed Bar



Flow Sensor Calibration Failed - Troubleshooting

If the Flow sensor can not be calibrated, retry the calibration.

If the Flow sensor still can not be calibrated, call your local Authorized Service Organization or DrägerService (see “Daily and Preuse Checkout Form” for DrägerService contact information).

Calibrate O2 Sensor

1. Press the Calibrate O2 Sensor soft key.
The Calibrate O₂ Sensor Instruction window replaces the Standby screen soft keys (Figure 104).
2. Follow the instructions.
The Calibrate O₂ Sensor in Progress bar replaces the instruction window (Figure 105).
3. Upon completion of the calibration, the “O2 Sensor Calibration completed” message (Figure 106) or the “O2 Sensor Calibration FAILED” message (Figure 107) appears.

O2 Sensor Calibration Failed - Troubleshooting

If the O₂ sensor can not be calibrated, replace the O₂ capsule in the O₂ sensor housing (see “Inserting A New O2 Sensor Capsule” on page 46).

If the O₂ sensor still can not be calibrated, call your local Authorized Service Organization or DrägerService (see “Daily and Preuse Checkout Form” for DrägerService contact information).

Leak / Compliance Test

1. Press the Leak / Compl Test soft key.
The Leak / Compl Test Ventilator Preparation message replaces the Standby screen (Figure 108), followed by the Leak / Compl Test Instruction screen (Figure 109).
2. Follow the instructions on the Leak / Compl Test Instruction screen.
Upon completion of the instructions, the Leak / Compl Test Results screen appears (Figure 110 on page 94).

Figure 104. Calibrate O₂ Sensor Instruction Screen

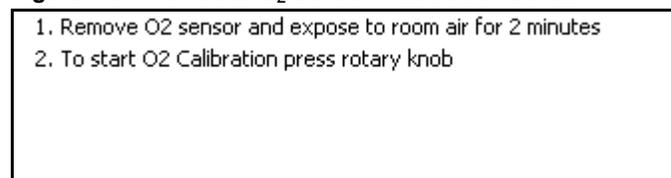

Figure 105. Calibrate O₂ Sensor in Progress Bar

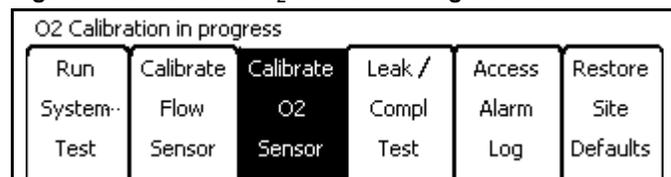

Figure 106. Calibrate O₂ Sensor Completed Bar

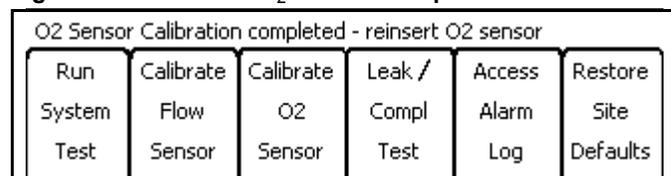

Figure 107. Calibrate O₂ Sensor FAILED Bar

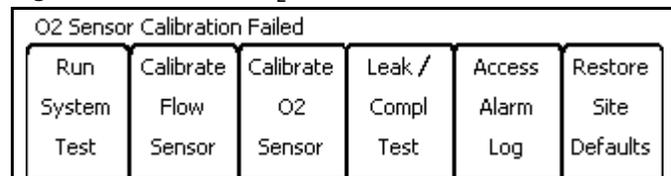

Figure 108. Leak / Compliance Test Vent Prep Message

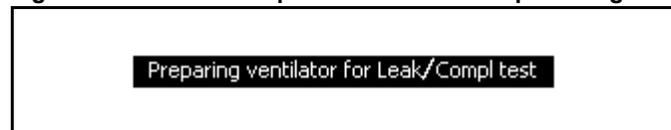
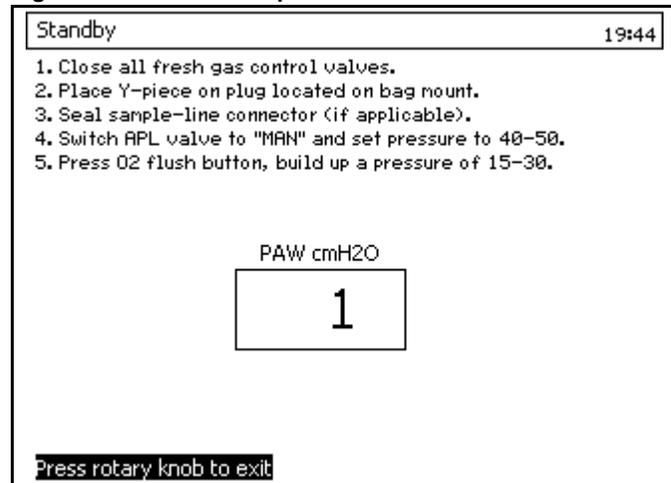
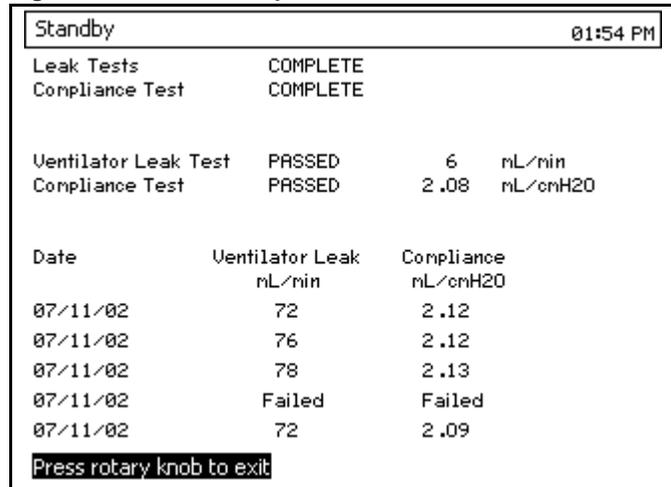

Figure 109. Leak / Compliance Test Instruction Screen



Part Number: 4117102-005 Rev: |

Figure 110. Leak / Compliance Test Results Screen



Access Alarm Log

1. Press the Access Alarm Log soft key.
The Alarm Log appears (Figure 111).
2. Turn the rotary knob to scroll through the Alarm Log.

When the “Clear Alarm Log” is selected and confirmed, all alarms in the Alarm Log are deleted.

Figure 111. Standby Screen Alarm Log

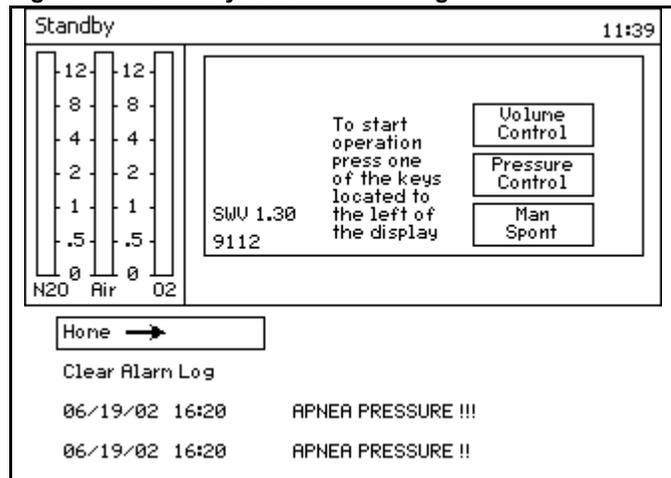

Restore Site Defaults

Press the Restore Site Defaults soft key. The pre-defined site default settings are restored, and the “Default settings restored” message appears (Figure 112).

Site default settings are set in the Standby Setup screen.

Figure 112. Site Defaults Restored Bar

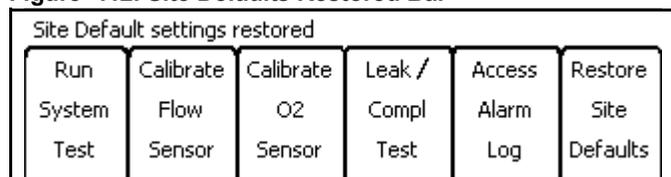

Standby Setup Screen

In Standby mode, press the Setup key.

The Standby Setup screen (Figure 113) replaces the Standby Screen.

The cursor, which appears over “Default Settings,” enables you to select “Default Settings” or “Configuration”.

Figure 113. Standby Setup Screen

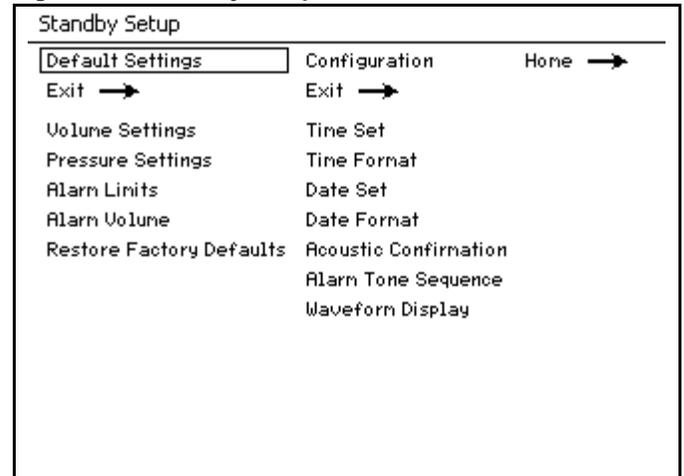

Default Settings

Select and confirm “Default Settings.”

The Default Settings column is selected (Figure 114).

If the return arrow (1 in Figure 114) is selected and confirmed, the Default Settings column is de-selected and “Default Settings” is selected (Figure 113).

The Default Settings Items are:

- Volume settings
- Pressure settings
- Alarm Limits
- Alarm Volume
- Restore Factory Defaults

Figure 114. Standby Setup Screen Default Settings Selected

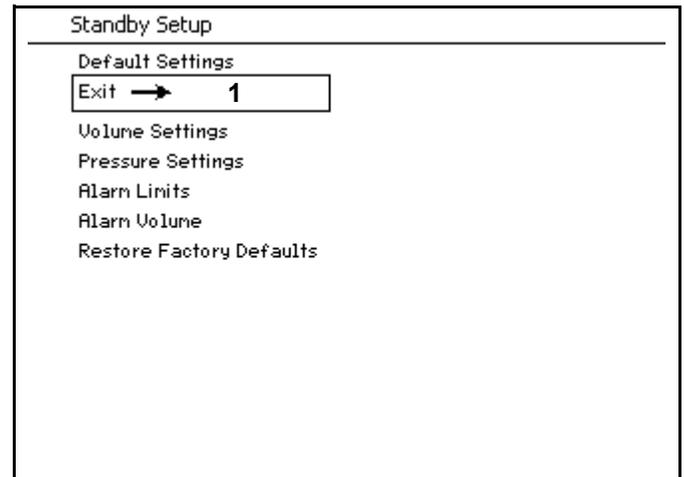

Volume Settings

1. Select and confirm “Volume settings.”
The Default Volume Settings window appears along the bottom of the Standby Setup screen (Figure 115).

Figure 115. Standby Setup Screen Default Volume

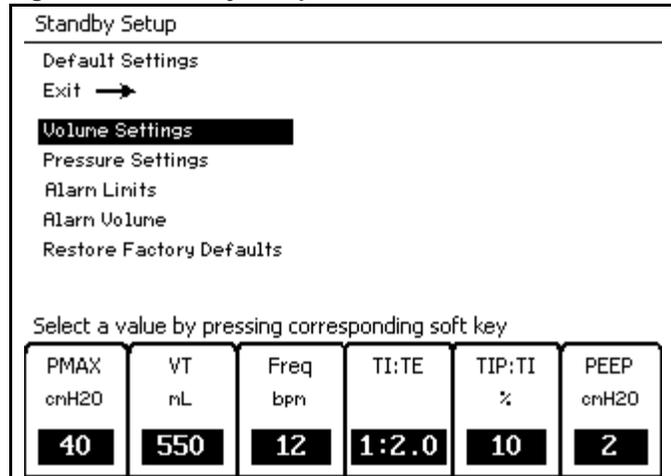

2. Press a soft key (ex., PMAx in Figure 116).
The cursor appears over the setting for the selected soft key.
3. Select and confirm a new setting value (ex., in Figure 116, the setting value was changed from 40 to 50).

Figure 116. Standby Setup Screen Default Volume Change

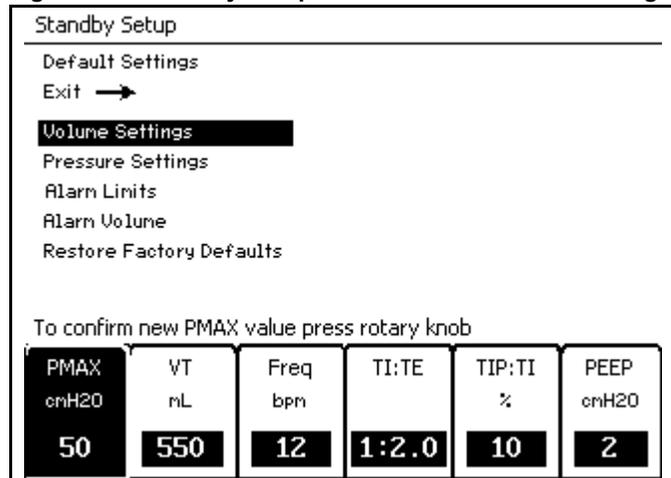

The Standby Setup screen instructs you to confirm the new default setting (Figure 117).

4. Repeat steps 2 and 3 for setting other parameter values.

Figure 117. Standby Setup Screen Default Volume Change Saved

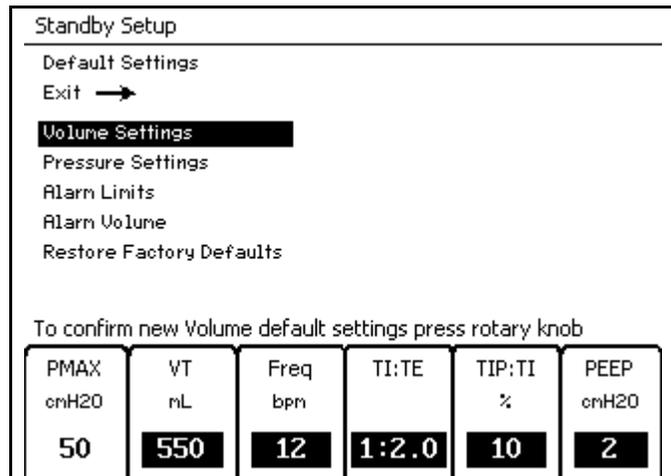

5. Confirm the new default setting.
The Default Volume Ventilator Settings window disappears, and the cursor appears over the return arrow.

Pressure Settings

Use the process example in “Volume Settings” and replace “Volume settings” with “Pressure settings.”

Alarm Limits

1. Select and confirm “Alarm Limits.”
The Default Alarm Limits window appears (Figure 118).

Figure 118. Standby Setup Screen Default Alarm Limits

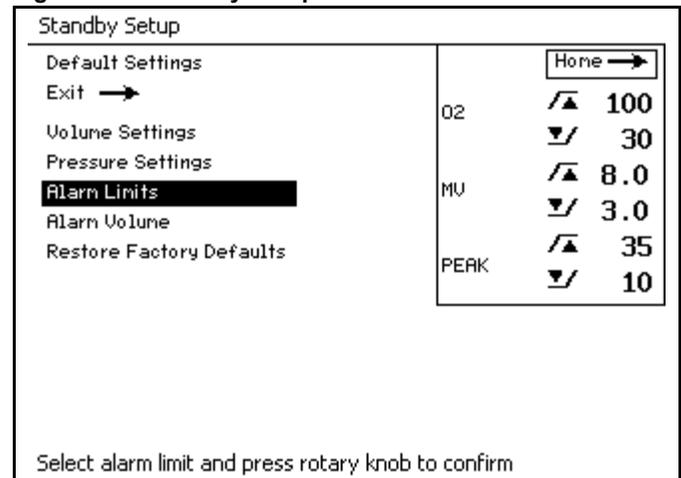

2. Select and confirm the desired alarm limit (Figure 119).

Figure 119. Standby Setup Screen Default Alarm Limits Select

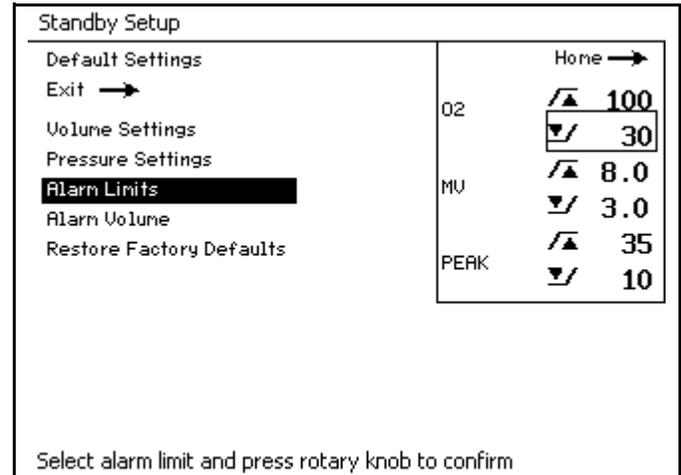

3. Select a new setting value (ex., in Figure 120, the setting value was changed from 30 to 25).
4. Confirm the new setting value.
The new setting is saved and the cursor appears over the return arrow.
5. Repeat steps 2 through 4 for setting other setting values.

Figure 120. Standby Setup Screen Default Alarm Limits Confirm

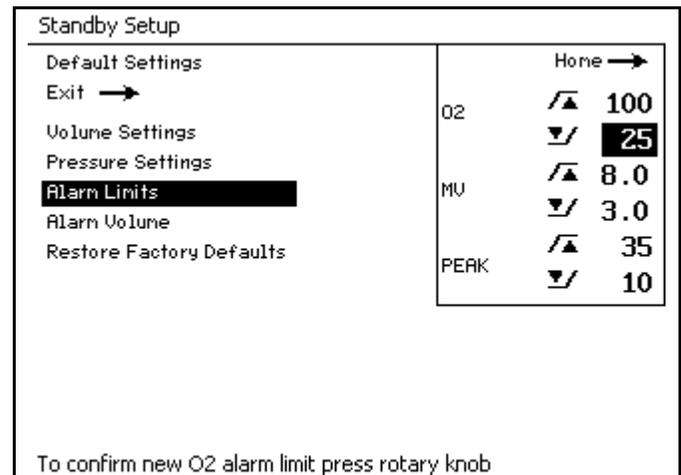

Part Number: 4117102-005 Rev: 1

Setting Alarm Limit Defaults

When the anesthesia machine is started, it uses the default alarm limit values that were established the last time the machine was configured. These values can be viewed and changed in the Alarm Limit window.

The Alarm Limit window is deactivated if the rotary knob is not used within 15 seconds, if the Alarm Limit key is pressed again, or if any other key is pressed.

Alarm Variables

- **Oxygen High Limit** — The Oxygen High Alarm Limit range is from 19% to 100%. It is not possible to set the Oxygen High Limit setting to less than or equal to the Oxygen Low Limit.
The factory default value for Oxygen High Limit is 100%.
- **Oxygen Low Limit** — The Oxygen Low Alarm Limit range is from 18% to 99%. It is not possible to set the Oxygen Low Limit setting to equal to or greater than the Oxygen High Limit.
The factory default value for Oxygen Low Limit is 20%.
- **Minute Volume High Limit** — The Minute Volume High Limit range is from 0.1 L/min. to 20.0 L/min.
The factory default value is 12.0 L/min.
- **Minute Volume Low Limit** — The Minute Volume Low Limit range is from 0.0 L/min. to 19.9 L/min.
The factory default value is 3.0 L/min.
- **Pressure High Limit** — The Pressure High Limit range is from 10 to 70 cmH₂O.
The factory default value is 40 cmH₂O.
- **Apnea Pressure Threshold** — The Apnea Pressure Threshold Limit range is from 5 to 30 cmH₂O.
The factory default value is 8 cmH₂O.

Alarm Volume

1. Select and confirm “Alarm Volume.”
The Default Alarm Volume Setting window appears next to “Alarm Volume” (Figure 121).

2. Select and confirm a new alarm volume value (ex., in Figure 122, the value is changed from “4” to “5”).

The new alarm volume value is saved and the Default Alarm Volume Setting window disappears.

Note: The value “1” is the minimum and the value of “10” is the maximum.

Figure 121. Standby Setup Screen Default Alarm Volume

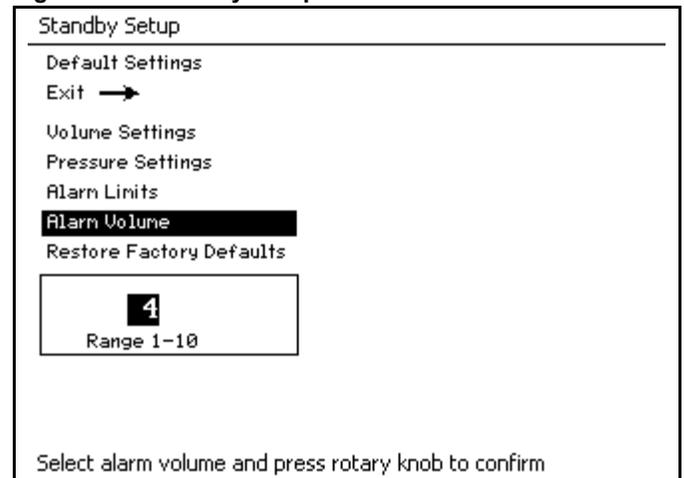
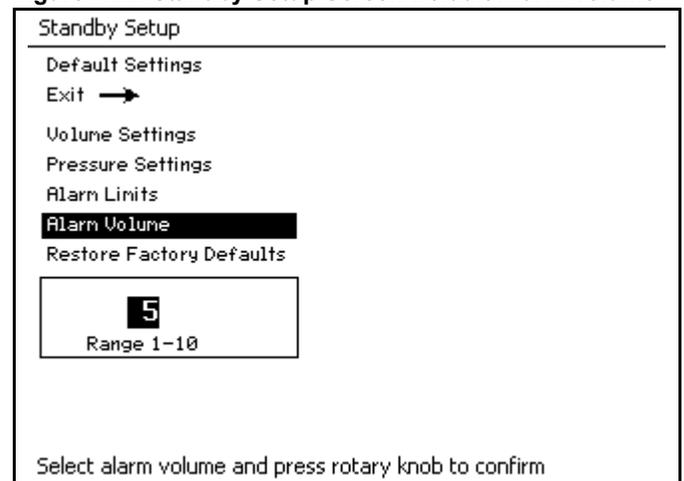

Figure 122. Standby Setup Screen Default Alarm Volume



Restore Factory Defaults

1. Select and confirm “Restore Factory Defaults.”

The Restore Factory Defaults Setting window appears next to “Restore Factory Defaults” (Figure 123).

2. Select and confirm “Yes” or “No.”

When “Yes” is selected and confirmed, the factory defaults are restored and replace the Default Settings.

The factory default settings:Volume Control

- P_{MAX} = 40
- VT = 600
- Freq = 12
- TI : TE = 1:2.0
- TIP : TI = 10
- PEEP = 0

Pressure Control

- P_{INSP} = 15
- Freq = 12
- TI : TE = 1:2.0
- Insp Flow = 30
- PEEP = 0

Alarm Default Settings for O₂

- High = 100
- Low = 20

Alarm Default Settings for MV

- High = 12.0
- Low = 3.0

Alarm Default Settings for Pressure

- High = 40
- Threshold = 8

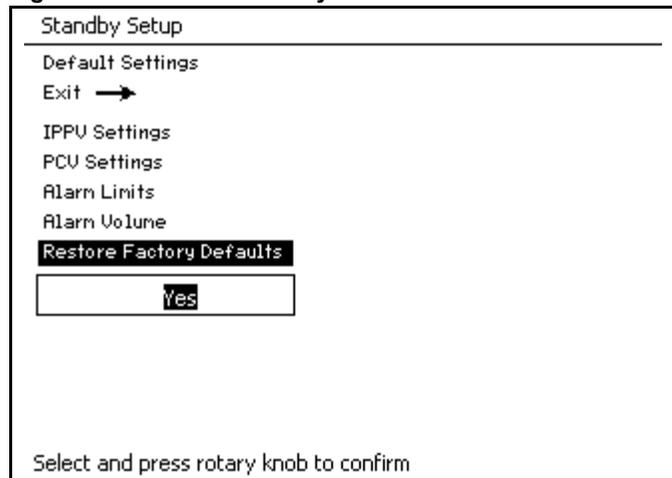
Alarm Audio Volume = 5**Figure 123. Restore Factory Defaults**

Standby Setup Screen

Configuration

Select and confirm “Configuration.”

The Configuration column is selected (Figure 124).

If the return arrow is selected and confirmed, the Configuration column is de-selected and “Configuration” is selected.

The Configuration Items are:

- Time Set
- Time Format
- Date Set
- Date Format
- Acoustic Confirmation
- Alarm Tone Sequence
- Waveform Display

Time Set

1. Select and confirm “Time Set.”

The Time Set window appears to the right of “Time Set” and the cursor appears over the hour field (Figure 125).

2. Select and confirm a new hour time value (ex., in Figure 126, the value is changed from “13” to “20”).

The cursor moves over the minute field (Figure 127).

Chapter 8 - Standby Mode Functions

Figure 124. Standby Setup Screen Configuration Settings Selected

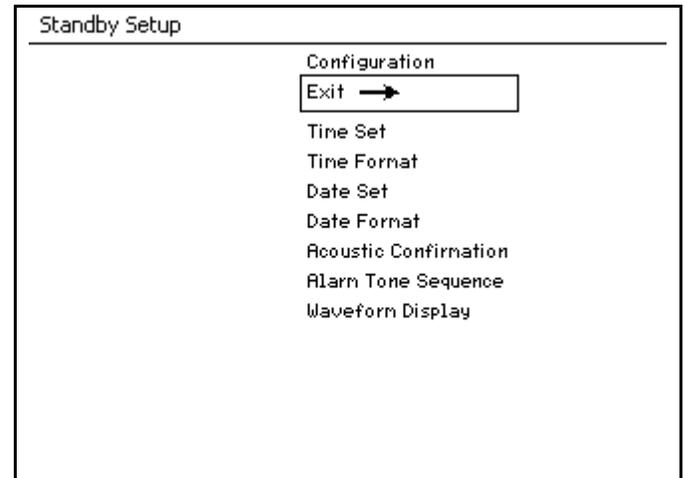

Figure 125. Standby Setup Screen Configure Time Hour Select

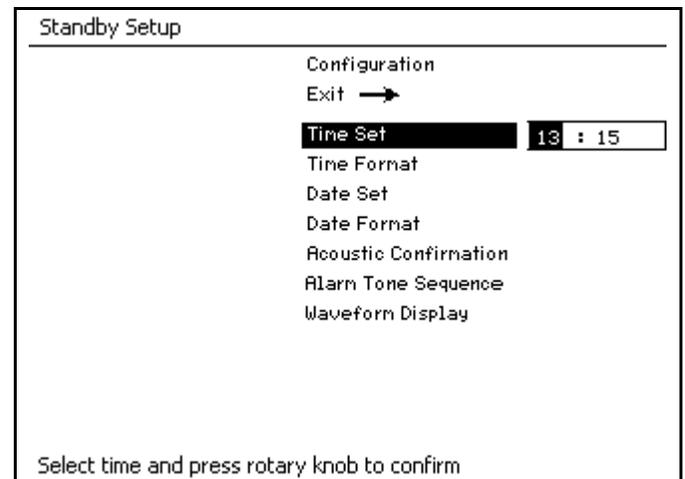
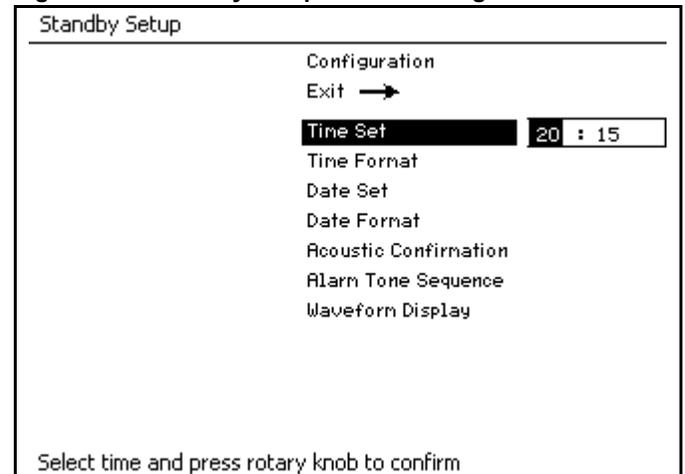

Figure 126. Standby Setup Screen Configure Time Hour



3. Select and confirm a new minute time value (ex., in [Figure 127](#), the value is changed from “15” to “30”).

The new time values are saved, the Time Set window disappears, and the cursor in the Configuration column appears over “Time Set.”

Note: This three-step process also applies to “Date Set” on [page 103](#).

Figure 127. Standby Setup Screen Configure Time Minute

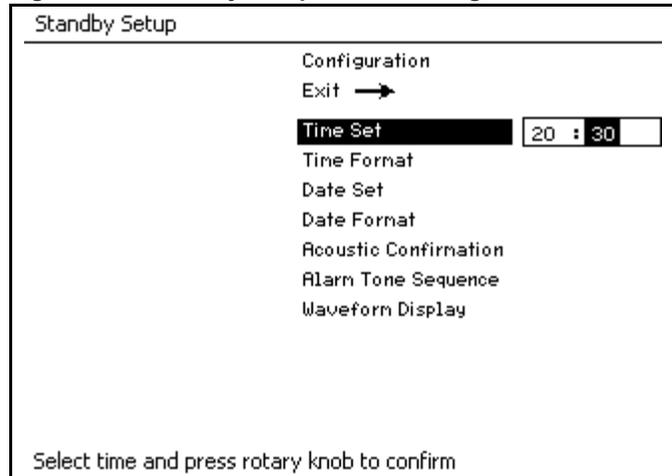

Time Format

1. Select and confirm “Time Format.”

The Time Format window appears to the right of “Time Format” and the cursor appears over the default time format value ([Figure 125](#)).

Figure 128. Standby Setup Screen Configure Time Format

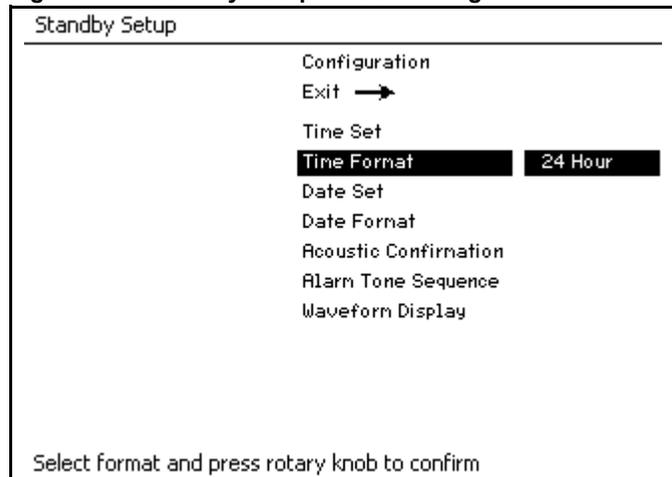

2. Select and confirm a new time format value (ex., in [Figure 126](#), the value is changed from “24:00 Hour” to “AM/PM”).

The new format value is saved, the Time Format window disappears, and the cursor in the Configuration column appears over “Time Format.”

The values that can be selected are “24 Hour” or “AM/PM.”

Note: This two-step process applies to all other items in the Configuration column except for “Time Set” and “Date Set.”

Figure 129. Standby Setup Screen Configure Time Hour

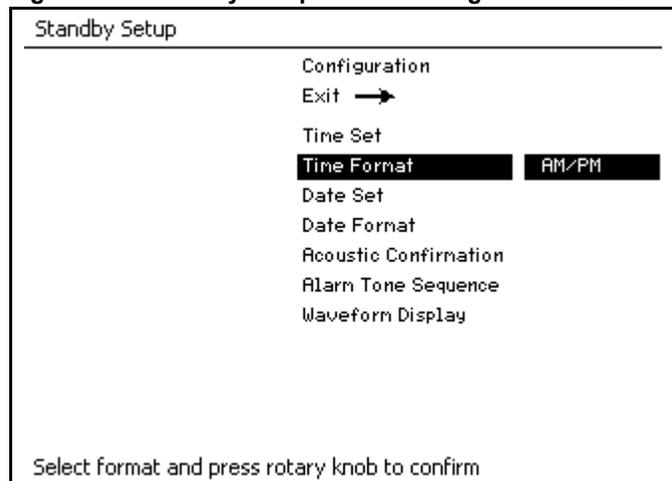

Date Set

The values that can be selected are numerical values applicable to day, month, and two-digit year.

Figure 130. Standby Setup Screen Configure Date Set Select

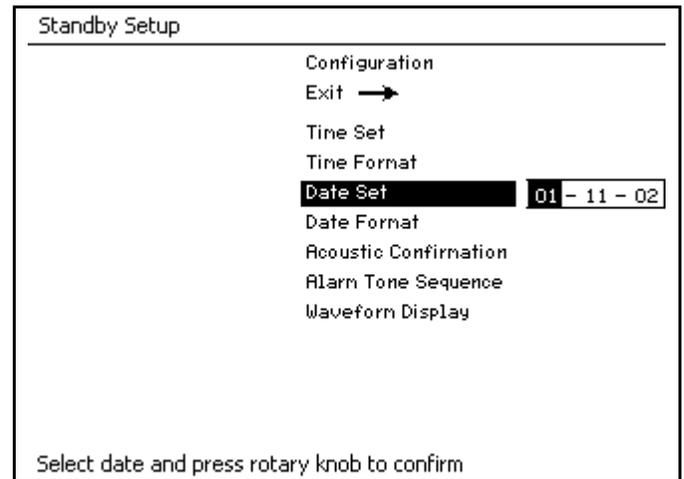

Date Format

The values that can be selected are "MM-DD-YY" or "DD-MM-YY."

Figure 131. Standby Setup Screen Configure Date Format Select

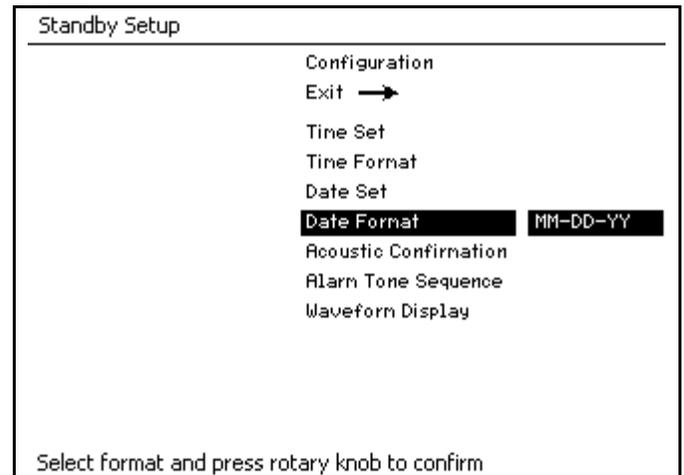

Acoustic Confirmation

The values that can be selected are "On" and "Off."

If "On" is selected, an acoustic confirmation is annunciated every time that the rotary knob is pressed.

Figure 132. Standby Setup Screen Configure Acoustic Confirmation

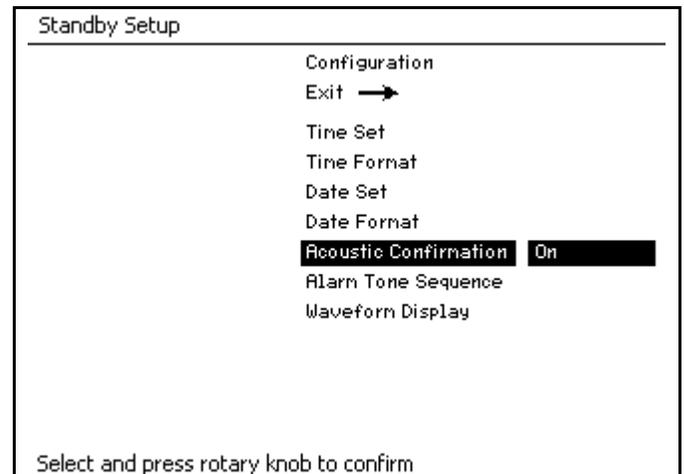

Alarm Tone Sequence

The values that you can select are "Dräger" and "EN 740."

Figure 133. Standby Setup Screen Alarm Tone Sequence Select

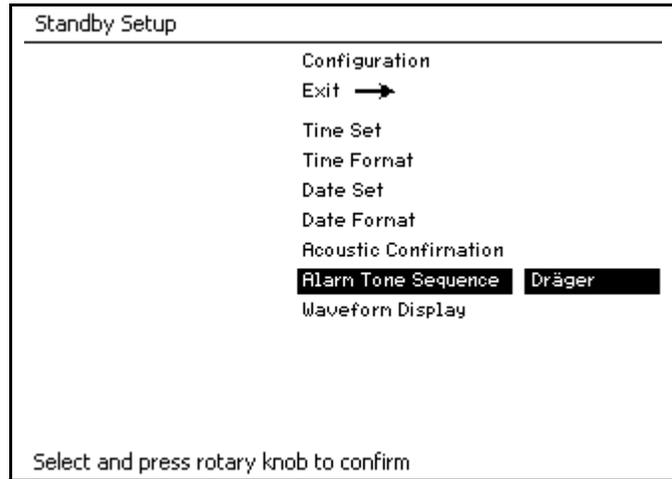

Waveform Display

The values that you can select are "Normal" and "Filled."

If "Normal" is selected, the waveform is not filled with a solid pattern, but appears as a line (1 in Figure 135).

Figure 134. Standby Setup Screen Waveform Display

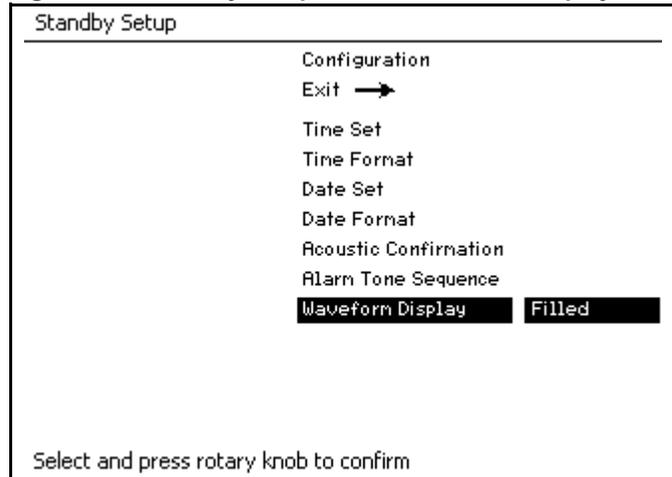
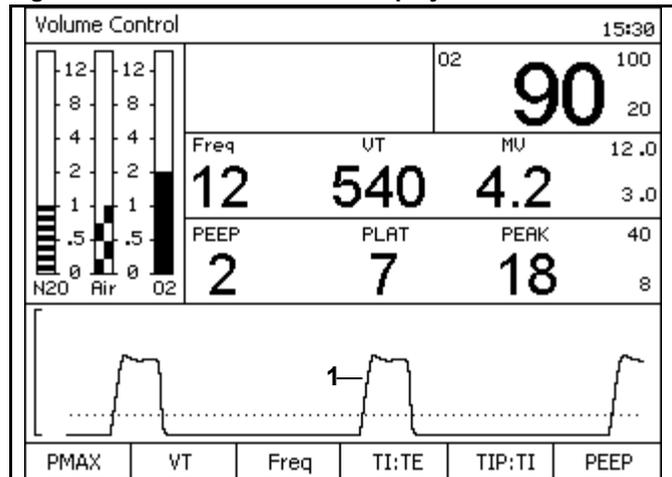

Figure 135. Normal Waveform Display



Routine Maintenance and Cleaning

Contents

Routine Maintenance	107
Disassembling	107
Preparing the Compact Breathing System	107
Dismantling the Inspiratory Valve	107
Dismantling the Expiratory Valve	107
Dismantling the Flow Sensor	107
Dismantling the APL-Valve	107
Dismantling the Absorbent Canister	108
Dismantling Parts of the Ventilator	108
Disinfecting/Cleaning/Autoclaving	109
Recommendations for Typical Cleaning and Disinfection After Use	110
Maintenance Intervals	111
When Required	111
Every 6 Months	111
Annually	111
After 3 Years	111
Checking Readiness for Operation	111

Routine Maintenance

Routine maintenance must be performed regularly to ensure safe and effective operation. Regularly check the condition of the absorbent and the overall condition of the machine, power cord, hoses, and breathing bag.

Disassembling

Preparing the Compact Breathing System

1. Leave the Dräger Vapor(s) on the machine.
2. Remove all breathing hoses.
3. Remove the breathing bag.
4. Remove the ventilation hose.
5. Remove the fresh gas hose from the breathing system.
6. Remove the anesthetic scavenging hose.
7. Detach the APL-bypass and the Peep/Pmax lines from the breathing system and from the side of the machine.
8. Remove the flow sensor cable.
9. Remove the O₂ sensor cable.
10. Remove the compact breathing system.

Dismantling the Inspiratory Valve

1. Unscrew the retaining nut.
2. Remove the inspection cap.
3. Extract the valve disc.

Dismantling the Expiratory Valve

1. Unscrew the retaining nut.
2. Remove the inspection cap.
3. Extract the valve disc.

Dismantling the Flow Sensor

1. Loosen fitting on the expiration port.
2. Extract the flow sensor.

Dismantling the APL-Valve

1. Unscrew the retaining nut.
2. Remove the APL-valve.
3. Unscrew the waste gas outlet port.

Dismantling the Absorbent Canister

1. Turn the absorber counter-clockwise and remove by pulling down.
2. Empty the expired CO₂ absorbent from the absorber into an appropriate refuse container.

Warning: Absorbent is caustic and is a strong irritant to the eyes, skin, and respiratory tract. When replacing the absorbent, take care not to spill its caustic contents.

3. Fill the absorber with fresh CO₂ absorbent.
4. Ensure that no CO₂ absorbent dust/particles have been deposited between the gaskets and sealing surfaces. Such dust and particles can cause leaks in the system.

Dräger recommends the use of Drägerorb 800 Plus.

Dismantling Parts of the Ventilator

The following numbers in boldface refer to [Figure 136](#).

1. Swing out the ventilator door (1).
2. Disconnect the ventilator chamber pressure sensor line (2) from the ventilator chamber pressure sensor line port (3).
3. Unlock the three clasps (4) to remove the cover (5).
4. Remove the diaphragm (6).

Figure 136. Dismantling the Ventilator

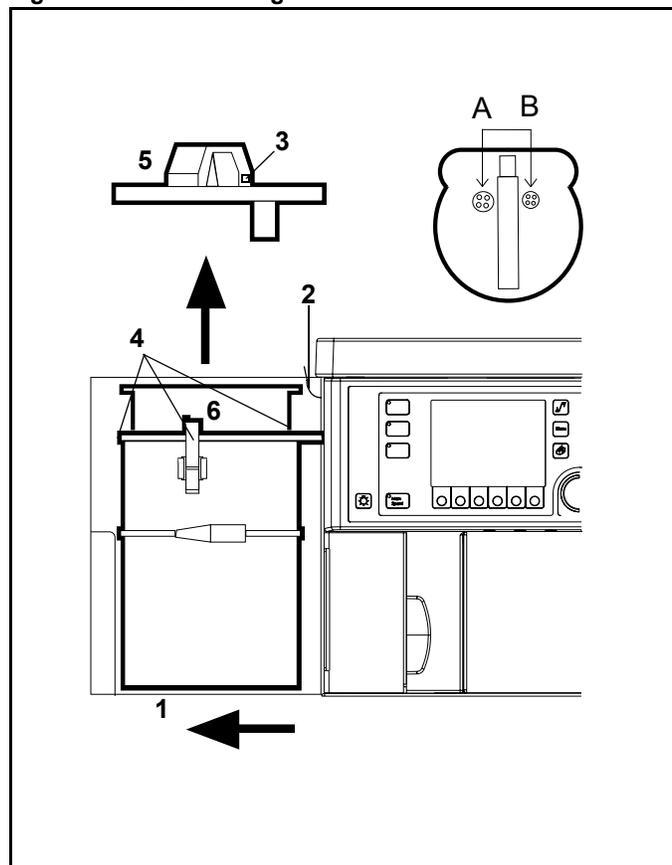

Disinfecting/Cleaning/Autoclaving

Clean and autoclave the Fabius GS Anesthesia Workstation and its parts according to the guidelines below. Follow your institution's policies regarding specific methods and agents for cleaning and sterilization. Determination of the need and frequency of sterilization of any particular component is the responsibility of the user institution.

Autoclaving procedures should be performed according to procedures established by the user institution following the specific instructions provided by the manufacturer of the sterilizing equipment or agent to be used. Such policies, procedures, and instructions should ultimately be consistent with established principles of clinical microbiology and infection control.

Caution: The exterior and certain other components of the anesthesia workstation consist of materials that are sensitive to certain organic solvents sometimes used for cleaning and disinfecting (e.g., phenols, halogen releasing compounds, oxygen releasing compounds, strong organic acids, etc.). Exposure to such substances may cause damage that is not always immediately apparent. Sterilization with ethylene oxide (EtO) or formaldehyde is also not permitted.

To prevent any damage, we recommend that only detergents and disinfectants are used that are compatible with the device, e.g. surface disinfectants on the basis of aldehydes, alcohols, or quarternary ammonium compounds for disinfection.

Ensure that all disinfectants are registered with the U.S. Environmental Protection Agency (or approved by your national authorities) for use as intended. Always follow the instruction labels specifically with respect to prescribed concentrations and the necessary exposure times.

Disinfectants often contain – besides their main active agents – additives that can also damage materials. When in doubt, ask the supplier/manufacturer of the disinfectant/cleaning agent.

Caution: The Fabius GS and its components must not be treated with formaldehyde vapors or ethylene oxide!

Warning: Follow all of your accepted hospital procedures for disinfecting parts contaminated with body fluids (protective clothing, eyewear, etc.).

Recommendations for Typical Cleaning and Disinfection After Use

- A Washing Machine (Wet pasturization at 70° C, 158° F, for 30 minutes after detergent cleaning)
 - B Wiping (Glutaraldehyde-based formulations of 2%; ethyl or isopropyl alcohol at 70% to 90%; sodium hypochlorite (5.2% household bleach) 1:500 dilution (100 ppm free chlorine))
 - C Immersion (Glutaraldehyde-based formulations of 2%)
 - D Autoclaving (Including steam or hot air at 134° C, 273° F). Use your manufacturer's or your facility's recommendations.
 - 1 Per patient
 - 2 Daily
 - 3 Weekly
 - 4 Monthly
- * Front daily, other surfaces weekly

Table 6. Schedules for Fabius GS Anesthesia Workstation

Components Processed	Schedules			
	A	B	C	D
Workstation (outside)		B *		
Vaporizers		B 2		
Power cable, gas supply hoses		B 4		
Breathing bag and hose and Y-piece	A 1	B 1		D 1
Diaphragm	A 1		C 1	D 1
Breathing system	A 1		C 1	D 1
Valve discs	A 1		C 1	D 1
Ventilator hose				D 1
Ventilator cover				D 1
APL-valve				D 1
Exhaust port				D 1
Control lines and cables (outside)		B 3		
Expiratory port	A 1		C 1	D 1
Absorber and insert	A 1		C 1	D 1
Flow sensor (outside)		B 2	C 2	
AGS housing	A 1		C 1	D 1
AGS flow tube (no filter)		B 1		D 1
AGS buffer vol. container	A 1		C 1	D 1
AGS transfer hose	A 1		C 1	D 1

Maintenance Intervals

Clean and disinfect the machine and components before each service (and also when returning for repair).

When Required

- Replace the O₂ sensor when calibration is no longer possible.
- Replace the flow sensor when calibration is no longer possible.
- Replace the pressure-measuring line (silicone rubber hose and sleeve).
- Replace APL-bypass and PEEP and Pmax silicone rubber hoses.
- Replace the ventilator hose if it is discolored or damaged.

Every 6 Months

Inspection and service by trained service personnel. Draeger Medical, Inc. recommends DrägerService.

- Fabius GS
- Breathing systems
- Dräger Vapor
- Sensors
- Ventilator hose

Annually

- Replace the bacterial filter on the pressure-measuring line.
- Replace the diaphragm in the ventilator (patient).
- Replace Vapor O-Rings

After 3 Years

By trained service personnel:

- Replace the lead gel rechargeable battery for the back-up power supply.
- Replace the diaphragm and O-rings of the ventilator (piston).
- Replace breathing system canister assembly and associated seals.

Checking Readiness for Operation

Refer to [“Daily and Preuse Checkout Form”](#) in the Appendix.

Troubleshooting

Contents

Table 8. Alarm Message, Probable Cause, and Remedy 115

Part Number: 4117102-005 Rev: —

Table 7. Alarm Message, Probable Cause, and Remedy

Alarm Message	Probable Cause	Remedy
AIRWAY PRESSURE HIGH	Upper alarm limit for airway pressure has been exceeded, ventilation hose is kinked. Alarm limit has been set too low.	Check hose system on anesthesia machine. Check breathing circuit or alarm limit value.
APNEA FLOW	Breathing/ventilation stops. Leak or disconnect in breathing circuit.	Check ventilator. Check breathing circuit.
APNEA PRESSURE	Inadequate fresh-gas supply. Breathing/ventilation stops. Leak or disconnect in breathing circuit.	Ensure adequate fresh-gas supply. Check ventilator. Check breathing circuit.
BATTERY LOW	AC failure and battery < 20% = Advisory AC failure and battery < 10% = Caution	Restore mains power.
CHECK BATTERY	UPS is not functional.	Replace fuse. Call your local Authorized Service Organization or DrägerService (see “Daily and Preuse Checkout Form” for DrägerService contact information).
CONTINUOUS PRESSURE	Breathing pressure above threshold for more than 15 seconds.	Check breathing circuit. If in ManSpont mode, check fresh gas flow.
EXP PORT LEAKAGE	Expiratory flow of more than 15 mL measured during inspiration.	Check expiratory valve and valve disk. Check tubing of expiration control line. Follow the procedure to calibrate flow sensor. Call your local Authorized Service Organization or DrägerService (see “Daily and Preuse Checkout Form” for DrägerService contact information).
EXP PRESSURE HIGH	Peep is 4 cmH ₂ O above the Peep setting in an automatic ventilation mode.	Check PEEP/PMAX, etc. hoses for kinks.
FLOW SENSOR CAL DUE	More than 18 hours passed since last flow sensor calibration.	Follow the procedure to calibrate flow sensor.
FLOW SENSOR FAIL	Flow sensor has not been calibrated. Sensor faulty.	Follow the procedure to calibrate sensor. Replace sensor and calibrate. Call your local Authorized Service Organization or DrägerService (see “Daily and Preuse Checkout Form” for DrägerService contact information).
FRESH GAS LOW	Inadequate fresh-gas supply. Blocked/kinked hose. Leak or disconnect in breathing circuit.	Ensure adequate fresh-gas supply. Check hoses. Check breathing circuit.
INSP O2 HIGH	Inspiratory O ₂ concentration exceeds the upper alarm limit.	Check flowmeter settings and O ₂ high alarm limit.
INSP O2 LOW	Inspiratory O ₂ concentration is below lower alarm limit.	Check O ₂ supply. Check flowmeter settings and O ₂ low alarm limit.
INSP PRES NOT REACH	Set pressure not achieved while ventilating in Pressure Control mode.	Check ventilator and P _{insp} settings.
MINUTE VOLUME HIGH	Minute volume has exceeded upper alarm limit. Flow sensor has not been calibrated. Sensor faulty.	Calibrate flow sensor. Replace if necessary.

Part Number: 4117102-005 Rev: —

Alarm Message	Probable Cause	Remedy
MINUTE VOLUME LOW	Minute volume has fallen below lower alarm limit. Blocked/kinked hose. Leak in breathing system. Reduced volume due to pressure limitation. Reduced lung compliance. Flow sensor not calibrated or faulty.	Check breathing circuit and alarm limit. Check breathing circuit. Check breathing system. Check Pmax setting on ventilator control panel. Check ventilator settings. Follow the procedure to calibrate flow sensor and replace if necessary.
NO FRESH GAS	Inadequate fresh-gas supply. Fresh-gas control valve closed	Ensure adequate fresh-gas supply. Open fresh-gas control valve.
O2 SENSOR CAL DUE	More than 18 hours passed since last oxygen sensor calibration.	Follow the procedure to calibrate oxygen sensor.
O2 SENSOR FAIL	O2 sensor has not been correctly calibrated. O2 sensor replaced and/or not calibrated. O2 sensor used up. O2 sensor disconnected. Faulty sensor cable.	Follow the procedure to calibrate O2 sensor. Follow the procedure to calibrate O2 sensor. Replace sensor capsule and calibrate. Connect O2 sensor assembly. Replace O2 sensor housing assembly.
O2 SUPPLY LOW	O ₂ supply line has less than minimum pressure permitted (approximately 20 psi).	Check O ₂ supply and cylinder backup.
PEEP HIGH	Peep is higher than 4 cmH ₂ O in ManSpont mode.	Check APL-valve setting and/or fresh gas flow.
POWER FAIL	Mains not connected. Facility power failure.	Connect mains.
PRES APNEA ALARM OFF	Pressure alarms off in ManSpont.	
PRESSURE LIMITING	Measured pressure equals or exceeds Pmax ventilator setting.	Check ventilator and Pmax settings.
PRESSURE NEGATIVE	Measured breathing pressure is less than -5 cmH ₂ O.	Check breathing circuit and ventilator settings.
PRESSURE SENSOR FAIL	Faulty sensor or pressure not calibrated.	Call your local Authorized Service Organization or DrägerService (see "Daily and Preuse Checkout Form" for DrägerService contact information).
PRES THRESHOLD LOW	Ventilation parameters were changed without changing alarm settings. Breathing pressure leak or partial disconnection occurs when the threshold pressure alarm limit is set significantly lower than the peak pressure.	Push the Auto Set soft key and check ventilator settings. Check breathing circuit.
RS232 COM FAIL	External monitor cable disconnected.	Check monitor interface cable.
SPEAKER FAIL	Primary speaker failed.	Call your local Authorized Service Organization or DrägerService (see "Daily and Preuse Checkout Form" for DrägerService contact information).
VENTILATOR FAIL	Ventilator not assembled correctly.	Check diaphragm and close cover. Check PEEP/PMAX line for disconnect or leak. Select Standby Mode and switch back to the previous ventilation mode.
VOLUME ALARMS OFF	Volume alarms turned off by operator in ManSpont mode.	

Components

Contents

Front View 119

Compact Breathing System (Top View) 120

Rear View (3-Gas Supply Connections) 121

Part Number: 4117102-005 Rev: —

Front View

Figure 137. Compact Breathing System and Front of Machine



- 1 O₂ sensor on inspiratory valve
- 2 Inspiratory valve
- 3 Switching lever **MAN** and **SPONT** on pressure limiting valve
- 4 Pressure-limiting valve for manual ventilation (APL valve)
- 5 Airway pressure gauge
- 6 Dräger Vapor anesthetic agent vaporizer
- 7 Oxygen flush
- 8 Total fresh gas flowmeter
- 9 Ventilator
- 10 Ventilator control panel (settings for ventilation parameters and airway monitoring)
- 11 Ventilator hose

Part Number: 4117102-005 Rev: —

Compact Breathing System (Top View)

Figure 138. Compact Breathing System

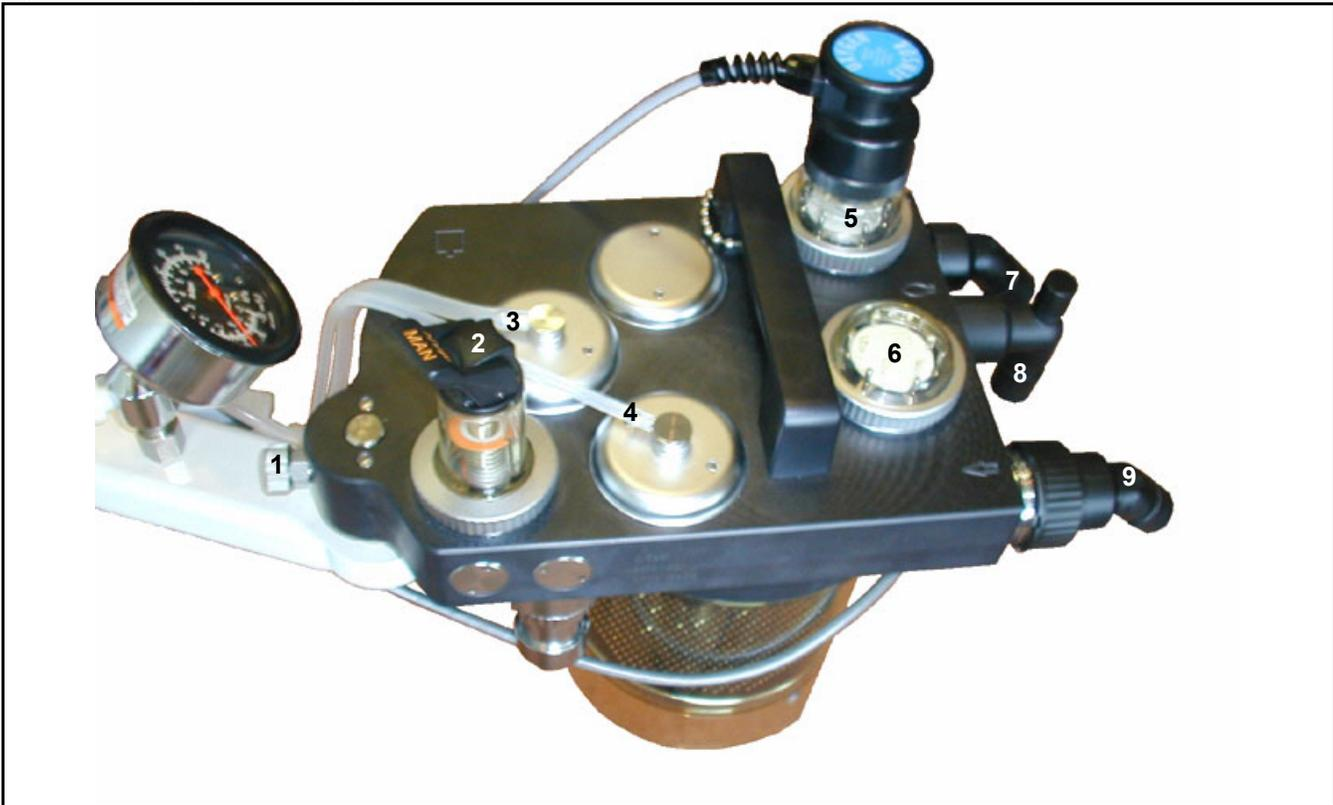

- 1 Plunger
- 2 Switching lever **MAN** and **SPONT** on pressure limiting valve
- 3 APL Bypass valve connection port
- 4 PEEP/PMAX valve connection port
- 5 Inspiratory valve
- 6 Expiratory valve
- 7 Inspiratory port
- 8 Connector for breathing bag
- 9 Expiration port

Rear View (3-Gas Supply Connections)

Figure 139. Compact Breathing System and Back of Machine



- 1 Power cable
- 2 On/off switch
- 3 Fuse
- 4 Connectors for medical gas pipeline supply (central supply)
- 5 Connectors for gas cylinder supply (reserve supply)

Part Number: 4117102-005 Rev: —

Technical Data

Contents

- Technical Data 125
 - Ambient Conditions 125
 - Machine Data 125
 - Fuses 126
 - Electromagnetic Compatibility (EMC) 126
 - Electrical Safety Conformance 126
 - Ventilator 127
 - Anesthesia Gas Supply Module 128
 - Anesthetic Agent Vaporizer Interface 129
 - Breathing System 130
 - Low Oxygen Supply Pressure Alarm 130
 - S-ORC (Sensitive Oxygen Ratio Controller) 131
 - Serial Interface 131
- Diagrams 132

Part Number: 4117102-005 Rev: —

Technical Data

Ambient Conditions

During operation

Temperature	10 to 35 °C
Atmospheric pressure	700 to 1060 cmH ₂ O
Relative humidity	20 to 80%

During storage

Temperature	-10 to 60 °C
Atmospheric pressure	700 to 1060 cmH ₂ O
Relative humidity	10 to 90%

Machine Data

Gas supply from medical gas pipeline system

Pipeline System Pressure Range at Machine Connector	
O ₂ , N ₂ O, Air:	50 to 55 psi (3.4 to 3.8 bar)
	Note: Pipeline system supply pressure variation shall not exceed ± 10%
Gas supply connectors:	NIST or DISS (where required)
Each inlet is fitted with a non-return valve	
Pipeline Pressure Indicator Accuracy	± 3% of full scale from 40 to 120 psi (2.7 to 8 bar)
Piping Pressure Relief (Canada)	≤ 75 psi (520 kPa)

Gas supply from supplementary O₂ and N₂O cylinders (with pin-index connections)

Cylinder Connections	Pin-indexed hanger yokes (CGA V-1-1994)
Cylinder Gas Pressure	O ₂ , AIR 1900 psi (131 bar)
(typical full loads at 70 °F, 21 °C)	N ₂ O 745 psi (51.3 bar)
Cylinder Gauges	Conform to ASME B40.1 Grade B
Cylinder Gauge Range	O ₂ 0 to 3000 psi (206.8 bar)
	N ₂ O 0 to 3000 psi (206.8 bar)
	AIR 0 to 3000 psi (206.8 bar)

Internal Regulator Safety Relief Valve Pressure 70 psi

Equipment Class ⚡ Class 1, Type B, IPX0

Ingress of Fluids IPX0

Dimensions and Weight (Approximate)

Weight:
 Base unit with COSY and without supplementary cylinders and vaporizers 224 lbs. (101.6 kg)
 Dimensions (with COSY)*: (W) 89 cm x (H) 130.8 cm x (D) 84 cm
 Dimensions (without COSY): (W) 69 cm x (H) 130.8 cm x (D) 82 cm
 * **Note:** Width may vary with COSY arm position.

Power supply, Rating Non-configurable 100 – 240 Vac, 50/60 Hz., 2.3 A maximum

Rechargeable batteries

Rating: 24 V; 3.5 Ah
 Type: sealed, gelled lead-acid
 Recharging time: ≤ 16 hours on the mains or full operation time
 Operation time with fully charged batteries: 45 minutes, minimum

Fuses

The following numbers in boldface refer to Figure 140.

Mains fuses:(1)
 For 100-240V supply voltage:
 2x T2.5AL 250V IEC 127/III

Fuses located on circuit board:
 1x T1.6AL 250V IEC 127/III (2)
 1x T4AL 250V IEC 127/III (3)
 1x T2.5AL 250V IEC 127/III (4)

Battery fuse:
 1x T3.15AL 250V IEC 127/III (5)

Figure 140. Fuse Locations

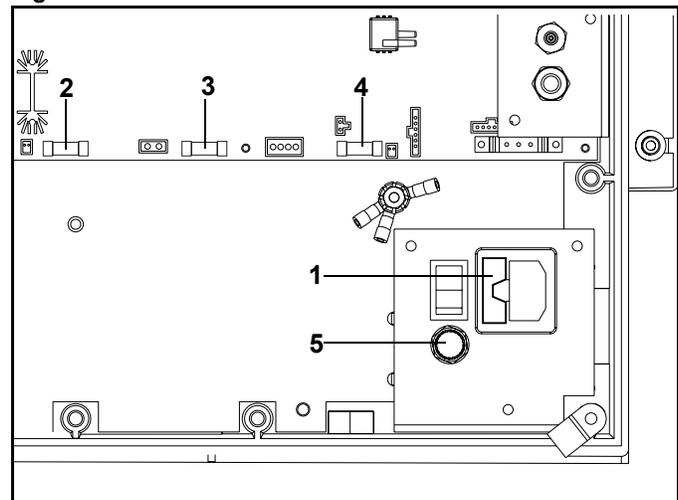

Electromagnetic Compatibility (EMC)

Conforming to EN 60601-1-2 and IEC 601-1-2

The operation of this anesthetic workstation or module may be adversely affected by electromagnetic interference exceeding the levels specified in EN 60601-1-2.

Electrical Safety Conformance

Conforms to:

- UL2601
- IEC 601-1
- CAN/CSA No. 601-1
- IEC 601-2-13

Ventilator

Control Inputs Ranges

Note: P = Pressure Control mode only; V = Volume Control mode only

P _{MAX} (V)	Pressure limiting	15 – 70 cmH ₂ O (1 cmH ₂ O resolution)
V _T (V)	Tidal volume	20 – 1400 mL (10 mL resolution)
f	Breathing frequency	4 – 60 bpm (1 bpm resolution)
T _i /T _e	Inspiration/expiration ratio	4 : 1 to 1 : 4
Tip/Ti (V)	Inspiration pause	0% - 50% (1% resolution)
PEEP	End-expiratory pressure	0 - 20 cmH ₂ O (1 cmH ₂ O resolution)
P _{insp} (P)	Inspiratory pressure	5 - 60 cmH ₂ O (1 cmH ₂ O resolution)
Insp Flow (P)	Inspiratory flow	10 - 75 L/min (1 L/min resolution)

Delivery Accuracy

P _{MAX}	Pressure limiting	± 5 cmH ₂ O of setting
V _T	Tidal volume	± 5% of setting or 20 mL, whichever is greater (discharged to atmosphere, no compliance compensation)
f	Breathing frequency	± 1 bpm of setting
T _i /T _e	Inspiration/expiration ratio	± 5% of setting
Tip/Ti (V)	Inspiration pause	± 25% of setting
PEEP	End-expiratory pressure	± 2 cmH ₂ O* or ± 20% of setting, whichever is greater

High Pressure Safety Relief Valve

75 ± 5 cmH₂O

Negative Pressure Safety Relief Valve (Ambient Air Inlet Valve)

-7.5 to -9 cmH₂O

System Compliance Compensation Measurement

0.2 to 6.0 ml/cmH₂O +/- 0.2 ml/cmH₂O or +/- 10% of actual compliance, whichever is greater

Part Number: 4117102-005 Rev: 1

Anesthesia Gas Supply Module**Fresh Gas Flow Indicators:**

O₂, N₂O, Air: Range and accuracy: 0.0 to 12.0 L/min \pm 10% of reading or 0.12 L/min
(into an ambient atmosphere of 14.7 psi (101.3 kPa) at 20° C).
Resolution: 0.1 L/min.

Fresh Gas Flow Stability:

O₂ and N₂O: \pm 10% of setting with pipeline pressures between 45 - 65 psi
Air \pm 10% of setting with pipeline pressures between 50 - 55 psi
Air flow rate will vary proportionally with supply pressures outside 50 - 55 psi.

Total Fresh Gas Flowmeter:

Range and accuracy: 0 to 10 L/min \pm 10% of full scale at STP,
calibrated with 50% O₂ / 50% N₂O gas mixture
0 to 10 L/min \pm 15% of full scale at STP for all other gas mixtures

Resolution: 0.5 L/min from 0.5 - 2 L/min
1.0 L/min from 2 - 10 L/min

O₂ flush (bypass): at 55 psi (3.8 bar): max. 50 L/min
at 50 psi (3.4 bar): min. 35 L/min

Common Gas Outlet Pressure Limit: 13 psi (0.9 bar), maximum

Anesthetic Agent Vaporizer Interface

Dräger Vapor quick-change plug-in system for up to two anesthetic agent vaporizers.
The connections are automatically closed and sealed when the vaporizer is removed.

Dräger Halothane Vapor
Dräger Enflurane Vapor
Dräger Isoflurane Vapor
Dräger Sevoflurane Vapor
Datex-Ohmeda Devapor/D-Tec for Desflurane

See specific Instructions for Use manuals for technical data of anesthetic agent vaporizers.

Monitoring and Measurement Display		Range	Resolution	Accuracy	Condition
Paw	Airway pressure (numeric)	-20 to 99 cmH ₂ O	1 cmH ₂ O	±4%*	
	Airway pressure (wave)	0 to 99 cmH ₂ O			
Ve	Expiratory minute volume	0 to 99.9 L/ min	0.1 L/ min	±15% [†]	ATPS [‡]
	Expiratory tidal volume	0 to 1500 mL	1 mL	±15% [†] or ±20 mL, whichever is greater	ATPS [‡]
Note: For end-tidal values of Desflurane exceeding 12%, tidal and minute volume accuracies may exceed ±15%					
f	Breathing frequency	2 to 99 bpm	±1 bpm	±1 bpm	
FiO ₂	O ₂ measurement in the main gas flow	10 to 100 vol.%	1 vol.%	±3 vol.%	with reference to ambient pressure during calibration
	Response time	Less than 25 seconds			
	Service life of O ₂ sensor cell	≥ 8 months at 25°C, 50% relative humidity, 50% O ₂ gas mixture (or ≥ 5000% hour O ₂)			

* Max. ± 4% of the measured value or ± 2 cmH₂O, whichever is greater.

[†] At standard test conditions per EN740 Annex DD and fresh gas flow = 2 times Ve.

[‡] ATPS = Ambient Temperature Pressure Saturated Gas

Breathing System

Compact Breathing System			
Volume: 2.8 L + bag Compliance: 0.22 mL/cmH ₂ O* in automatic mode (Volume Control) [§] Absorber volume: 1500 mL			
Resistance of Breathing System			
	5 L/min	30 L/min	60 L/min
Inspiratory Resistance	0.5 cmH ₂ O*	1.3 cmH ₂ O*	2.8 cmH ₂ O*
Expiratory Resistance	0.7 cmH ₂ O*	2.4 cmH ₂ O*	4.8 cmH ₂ O*

[§] Compliance exclusive of patient hoses.
Note: Resistance tests in compliance with EN740-107.4.2.1
* cmH₂O, Dry

Classification **II b**
Conforming to Directive 93/42/EEC Appendix IX

UMDNS Code **10-134**
Universal Medical Device Nomenclature System

Control Inputs Ranges
APL-Valve MAN mode 5 - 70 cmH₂O
 SPONT mode 1.5 cmH₂O

Pressure Required to Open a Wet Unidirectional Valve
Moist: 1.5 cmH₂O
(Tested in accordance with EN740)

Pressure Generated by a Wet Unidirectional Valve
Moist: 3.1 cmH₂O (Tested in accordance with EN740)

Low Oxygen Supply Pressure Alarm

Alarm limit	Warning signal when the pressure drops below 20 ± 4 psi
Alarm signal	High priority alarm (Warning)
LED indicator	The red LED indicator in the O ₂ area of the gas flow control interface will flash until the O ₂ supply is restored.

S-ORC (Sensitive Oxygen Ratio Controller)

S-ORC is a control element which guarantees a minimum O₂ concentration in the fresh gas flow. As from a flow rate of approx. 200 mL/min., the N₂O concentration in the fresh gas can be freely set between 0 and 75%.

During O ₂ shortage	S-ORC limits the N ₂ O concentration in the fresh gas, so that the O ₂ concentration does not drop below 23 vol.%.
N ₂ O metering valve open and O ₂ metering valve closed or O ₂ flow less than 0.2 L/min	S-ORC prevents N ₂ O flow
During N ₂ O failure	O ₂ may still be administered. No alarm.

Serial Interface

Type: RS - 232
 Baud Rates: 4800, 9600, 19.2K
 Parity: Odd, Even, None
 Data Bits: 7 or 8
 Stop Bits: 1 or 2
 Protocol: Vitalink. Medibus

Part Number: 4117102-005 Rev: —

Diagrams

Figure 141. Gas flow diagram (Compact Breathing System)

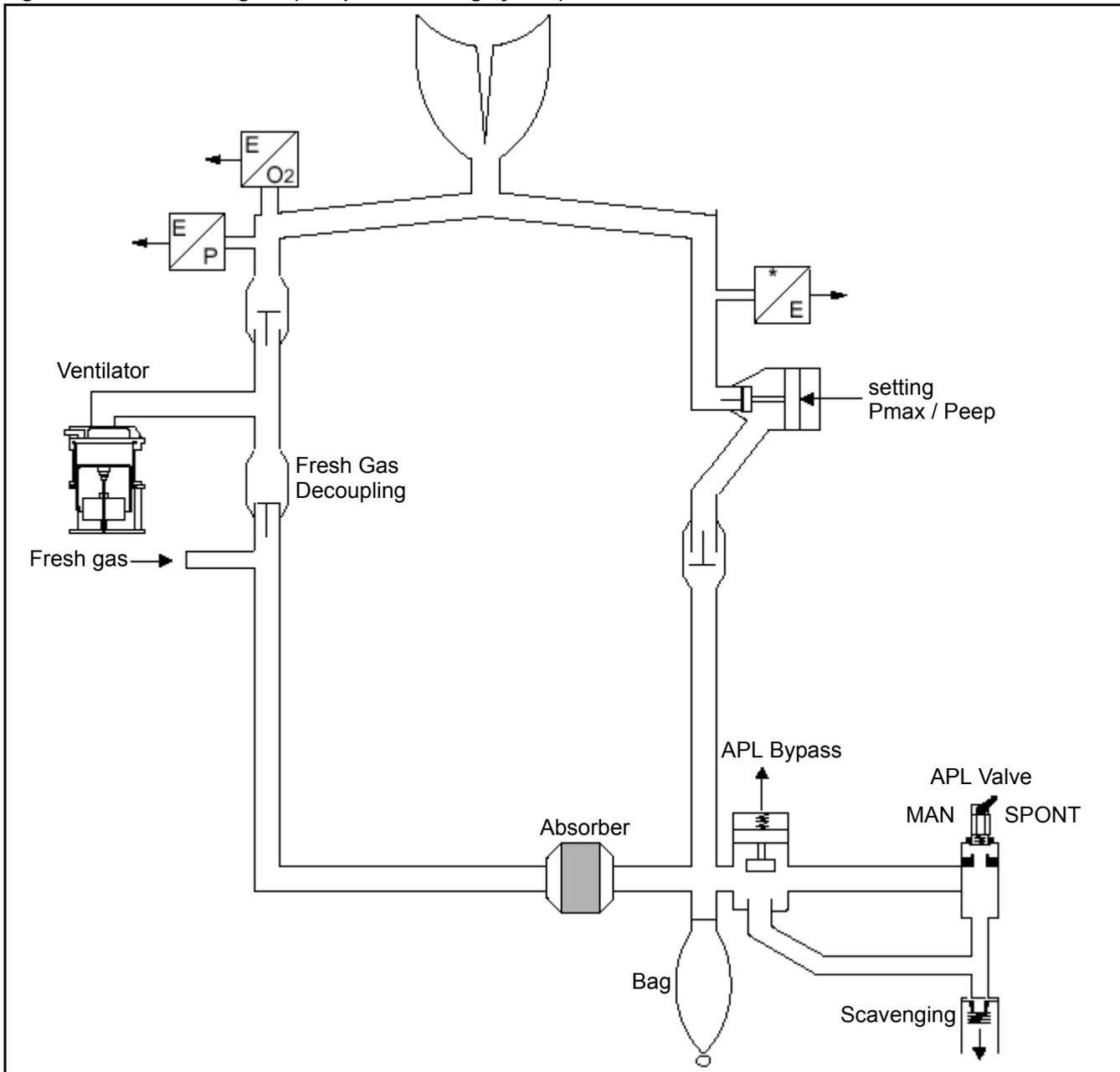

Part Number: 4117102-005 Rev: —

Figure 142. Schematic Diagram of Internal Gas Flow

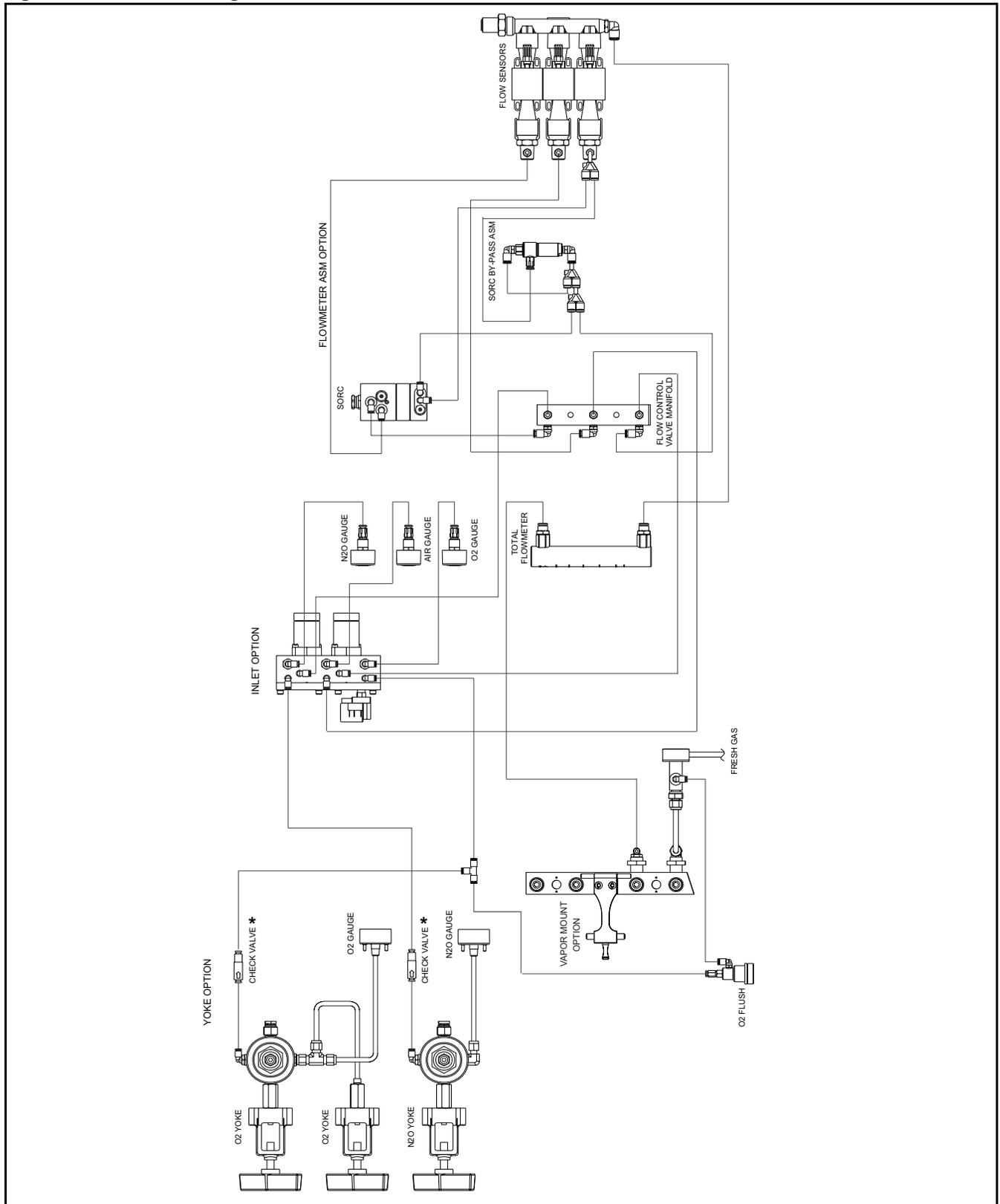

* Note: The check valve is not installed on the Canadian machine.

Part Number: 4117102-005 Rev: —

Daily and Preuse Checkout Form

Before operating the Fabius GS, the following checkout verification form must be completed to ensure that the machine is ready for use. Do not insert any additional components into or modify the anesthesia system after the checkout procedure is started.

This is a recommended procedure. Follow your institution's policies for specific checkout procedures.

Caution: If any check can not be carried out satisfactorily, the machine must not be used.

Call your local Authorized Service Organization or DrägerService at:

DrägerService

Draeger Medical, Inc.

3122 Commerce Drive

Telford, PA 18969

Tel: (215) 721-5402

(800) 543-5047

Fax: (215) 721-5784

Appendix - Daily and Preuse Checkout Form

Please note that this Daily Pre-use check list takes into consideration all possible configurations of the Fabius GS. The clinician need only use those areas that apply to their specific Fabius GS configuration.

All checks must be carried out daily before equipment is used. The person who carries out the checks must be fully conversant with the Instruction for Use. Checks marked with a **P** must be carried out before each patient use. These pages should be removed and copied to establish a daily record of machines checks. Mark each function when checks have been satisfactorily completed.

Fabius GS Serial Number

Pre-conditions

- Inspection intervals for machine and accessories are current
- P** Machine fully assembled and connected
 - Monitors (O₂, P, V, CO₂, anesthetic agent) (when present) switched on and functioning, self test carried out satisfactorily
 - System diagnostics for Fabius GS carried out
- P** Sampling line for gas monitoring (when present) connected to Luer lock on the Y-piece, correct anesthetic agent selected
- P** Desflurane vaporizer (when being used) powered on

Checking Reserve Power

- P** Verify that battery is fully charged. (If the battery does not show full a charge, the battery operation time is not guaranteed to be 45 minutes.)

Checking the Medical Gas Connections

- Visually inspect all gas supplies from the medical gas pipeline system and cylinders to make sure that they connect properly and fit securely.
- Verify that all medical gas pipeline supplies are within acceptable pressure ranges.
- Open reserve gas cylinders (when present).
- O₂ pressure more than 1000 psi (70 bar)
- N₂O pressure greater than 600 psi (43 bar) if present
- Air pressure greater than 1000 psi (70 bar) if present
- Close reserve gas cylinders.

O₂ Flush Function

- Press O₂ flush: A strong flow of gas should be emitted from the patient connection.
- Release O₂ flush button: flow of gas from patient connection stops.

Appendix - Daily and Preuse Checkout Form

Checking the Flow Control/Metering System

- Activate ManSpont mode.
- Fully open the O₂ metering valve. O₂ flow of at least 10 L/min present.
- Fully open the N₂O metering valve. N₂O flow of at least 10 L/min present.
- Turn off the O₂ supply. Remove the O₂ connector and close the O₂ cylinder valve. The O₂ Low Supply Pressure Alarm LED is blinking. N₂O does not flow.
- Restore the O₂ supply: N₂O flow is present.
- Set O₂ metering valve to 1.5 L/min. N₂O flow = 3 L/min to 5 L/min
- Close the O₂ metering valve: No N₂O flow.
- Open the AIR flow control valve. Air flow of at least 10 L/min present.
- Close all metering valves.

Sensor Calibration

- Remove O₂ sensor housing from inspiratory valve dome
- Calibrate O₂ sensor
- Calibrate flow sensor
- Replace O₂ sensor

Checking the Gas Type

- Set the O₂ metering valve to approx. 3 L/min.
- Verify an O₂ concentration indication of approx. 100 vol.%.
- Close O₂ metering valve.

Vapor 19.n, Vapor 2000 (Tec 5)

- P Fastening; Latched down firmly and set vertically
- P Handwheel; In zero position and engaged
- P Filling level between min. and max.
- P Interlock; Locking function OK (when present)
- P Key-indexed filling system; Sealing key or pin inserted and closed tight. (when present) Filler opening locked shut.
- P Quik Fil or Funnel filling system; Locking screw tight (when present)

Desflurane Vaporizer (when present)

- P Fastening; Latched down firmly and set vertically
- P Handwheel; In zero position and engaged
- P Filling level between min. and max.
- P Operational light lit

Selectatec™

- P Fastening; Latched down firmly and set vertically
- P Handwheel; In zero position and engaged
- P Filling level between min. and max.
- P Interlock; Locking function OK (when present)

Checking the Condition of CO₂ Absorbent

- P Color change is no more than half the canister of CO₂ absorbent.

Leak Testing the Fresh Gas Circuit

Test once without the vaporizer and once with each Dräger Vapor with the handwheel set to zero.

- Go to Standby and press the Leak Test soft key. Follow the instructions on the screen.

If the system leaks (i.e. pressure drops):

- Check that all plug-in, push-fit and screw connectors fit tightly.
- Replace any missing or damaged seals. If necessary, call your local Authorized Service Organization or DrägerService.

Inspiratory and Expiratory Valves (Compact Breathing Systems)

Press the ManSpont key and confirm.

Set APL-valve to MAN position and adjust to 30 cmH₂O.

Press O₂ flush.

- P** Breathing bag for manual ventilation fills
- P** Inspiratory and expiratory valve discs move freely when the breathing bag is squeezed and released.

Pressure-Limiting Valve (Compact Breathing System)

- P** Set APL valve to MAN and 30 cmH₂O. Set fresh gas flow to 20 L/min.
- P** Press the ManSpont key and confirm.
- P** When the pressure waveform on the Breathing Pressure Trace window stabilizes (e.g., a flat line), flip the APL-valve to SPONT to release pressure.
- P** Peak pressure display on monitor reads 24 to 36 cmH₂O.

Checking Ventilator Operation

- P** Connect a breathing bag to the Y-piece to act as test lung.
- P** Press the Pressure Control key and confirm.
- P** Check that ventilation measurements are displayed.
- P** Check that the ventilator piston is cycling.
- P** Monitor the operation of the inspiratory and expiratory valve discs.
- P** Check that the breathing bag (test lung) on the Y-piece is ventilating.
- P** Press the Standby key and confirm.

Monitors

The alarm function can be tested by setting alarm limits to levels that are certain to trigger an alarm.

Check the alarm limit settings. The monitor alarm limits are automatically set to a default configuration when the SYSTEM POWER switch is turned on. Check these settings and adjust them if necessary. Alarm limits can be adjusted at the beginning of or during a procedure. Also, make sure that any external monitors (if any) are connected properly.

Test the alarm functions for all monitors. Simulate alarm conditions and check for appropriate alarm signals.

- Test the O₂ monitor and alarm module.
- Test the volume monitor and alarm module.
- Test the pressure monitor and alarm module.
- Press the Standby key and confirm.

Appendix - Daily and Preuse Checkout Form

Additional Monitors (when present)

- Check the CO₂ monitor and alarm module.
- Check the anesthetic agent monitor and alarm module.

Anesthetic Gas Scavenging System

- P** Check the hose connections.
- P** Adjust the flow regulator to place the float between the "Minimum" and "Maximum" marks.
- P** Press and hold the O₂ flush button and verify that airway pressure is < 10 cmH₂O with Y-piece occluded.
- P** Close all flow control valves on the machine, with Y-piece occluded, and verify that airway pressure is > -0.5 cmH₂O .

Manual Ventilation Bag for Emergency Ventilation (when present)

- Check that the bag is functioning correctly by pumping manually.
- When the bag is squeezed, air must audibly and tangibly flow out of the mask cone; when the bag is released, it must rapidly recover its original shape.
- Block off the mask connector (cone) with the ball of your thumb: you should only be able to squeeze the bag a little.

P Before Connecting to Patient

Verify that

- all vaporizers are off (the handwheels are set to zero),
- the APL Valve is set as desired,
- all flowmeters indicate 0,
- the patient suction is level adequate, and
- the breathing system is ready to use (the bag is in place and all hoses are connected properly)

If any check can not be carried out satisfactorily, the machine must not be used.

Daily Checkout Signature

Name

--

Date

--

Preuse Checkout Signature

Name

--

Date

--

Preuse Checkout Signature

Name

--

Date

--

Preuse Checkout Signature

Name

--

Date

--

Appendix - Daily and Preuse Checkout Form

Preuse Checkout Signature

Name

Date

Preuse Checkout Signature

Name

Date

Preuse Checkout Signature

Name

Date

Preuse Checkout Signature

Name

Date

Preuse Checkout Signature

Name

Date

Preuse Checkout Signature

Name

Date

Preuse Checkout Signature

Name

Date

Preuse Checkout Signature

Name

Date

Preuse Checkout Signature

Name

Date

Preuse Checkout Signature

Name

Date

Preuse Checkout Signature

Name

Date

Preuse Checkout Signature

Name

Date

Appendix - Daily and Preuse Checkout Form

Preuse Checkout Signature

Name

Date

Preuse Checkout Signature

Name

Date

Preuse Checkout Signature

Name

Date

Preuse Checkout Signature

Name

Date

Preuse Checkout Signature

Name

Date

Preuse Checkout Signature

Name

Date

Preuse Checkout Signature

Name

Date

Preuse Checkout Signature

Name

Date

Preuse Checkout Signature

Name

Date

Preuse Checkout Signature

Name

Date

Preuse Checkout Signature

Name

Date

Preuse Checkout Signature

Name

Date



Directive 93/42/EEC
Concerning Medical Devices

The CE mark applies to
Fabius GS Anesthesia Machines
equipped with gas color codes
in compliance with EN 1089-3.

Dräger Medical, Inc.
3135 Quarry Road
Telford, PA 18969
USA
(215) 721-5400
(215) 721-9561 (Sales Fax)
(215) 723-5935 (Service Fax)
<http://www.draegermedical.com>

EC Representative:
Dräger Medical AG & Co. KGaA
Germany
Moislinger Allee 53 – 55
D-23542 Lübeck
(451) 882 - 0
FAX(451) 882-2080
<http://www.draeger.com>