

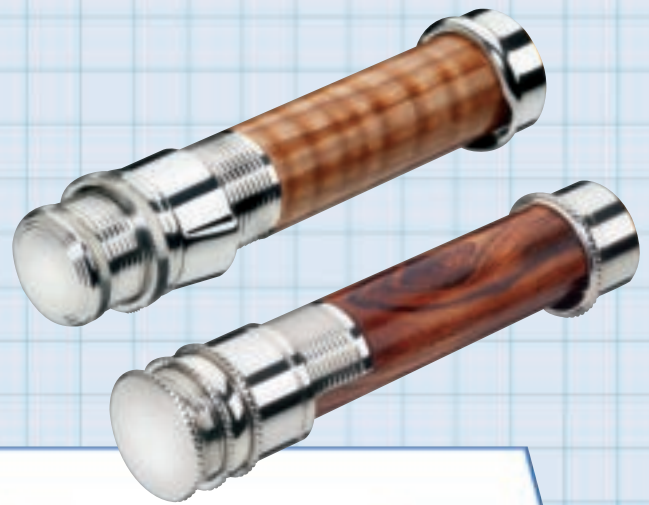

FINE ROD COMPONENTS & CASES



Material: Nickel Silver Finish: Bright Polished Plating: EverBright™		REC COMPONENTS A DIVISION OF EDGEWATER INTERNATIONAL, LLC Drawing No: NSGX-RK	
Drawing No: EJR Part Number: 1015	Approved: AGG Revision Date: 8/12/02	Drawing No: EJR Part Number: 875	Approved: AGG Revision Date: 6/15/00

ROD COMPONENTS

ADVANCED TECHNOLOGY • DESIGN SOLUTIONS • QUALITY • TRADITION • SINCE 1968



Silver Creek, Ketchum, Idaho

Photo A. Gnann



Providing Component and Case Solutions to Rod Manufacturers Worldwide Since 1968

For over 30 years REC has created fishing rod components that are aesthetically beautiful, fit perfectly, function flawlessly, and last a lifetime. Recent technological advancements have enabled us to employ numerically controlled precision manufacturing techniques thus allowing our customers the benefit of hand craftsmanship and close tolerances at a reasonable cost.

At REC, our mission is clear...*design and manufacture the highest quality rod components and rod cases while providing fair value and superior service to our customers worldwide.* REC components are fabricated from the finest raw materials available. Our nickel silver components are now made from our new and exclusive 18% nickel content alloy EverBright™. REC aluminum components are produced from high strength, hardened, aircraft grade alloys anodized to exacting military and industrial standards. Our salt water components are further protected through the use of an anodized hard coat and Teflon® finish providing for superior durability coupled with light weight; a combination unattainable with other metal alloys.

REC wood spacers are handcrafted from a variety of select North American hardwoods, impregnated wood, imported

exotic hardwoods, and highly figured burls. We pay particular attention to the details of our wood spacers by ensuring that the reel foot contour precisely matches the radius of the spacer. Many of our reel seats are provided with mortised wood spacers or slotted barrels which cradle and secure the reel foot from slippage.

REC reel seats and related components are precisely manufactured to fit right the first time and every time. REC played an active role in combination with our industry trade association (AFFTA) to create the standard by which rod component and reel manufacturers now comply. Our components meet this standard so you can be assured that each of our products will fit any reel made in compliance with the AFFTA standard.

With the exception of blanks, REC is capable of supplying everything required to build and case rods. We are dedicated to meet the needs of rod manufacturers, commercial custom builders, distributors, and dealers worldwide by providing creative solutions to the most demanding applications. The REC team stands ready to serve its customers in a prompt, courteous, and professional manner while delivering the highest quality rod components and rod cases.

New Reel Seat Models

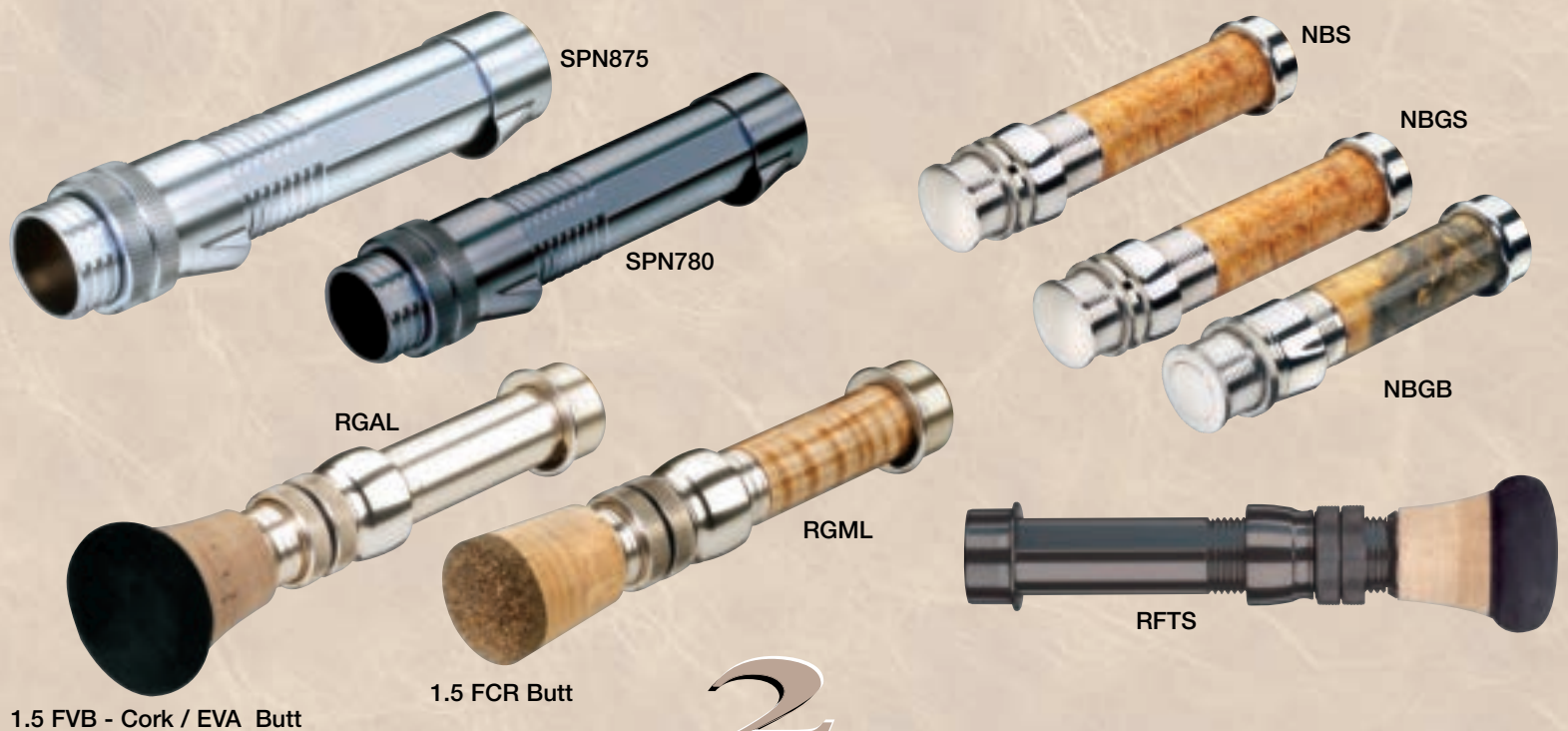

Reel Seats

REC offers both *EverBright* 18% nickel silver and high strength anodized aluminum hardware to complement its full line of reel seats. Nickel silver is noted for its exceptional fit, finish, and aesthetic beauty and is recommended in all applications except salt water where anodized aluminum is more durable. Our aluminum reel seats are offered in four standard anodized colors: Black, Pewter, Champagne, and our new "Nickel Silver" color (select models only). The following information is provided to assist you in selecting the proper reel seat for the application.

MASTER SERIES - NICKEL SILVER

Machined from REC's exclusive EverBright™ Nickel Silver Alloy - Substantially Brighter / Tarnish Resistant, Significantly Harder / Scratch Resistant. Requires less effort to maintain the classic elegance of nickel silver.

For the manufacturer or experienced rod builder we have created a collection of distinctive nickel silver reel seats for any rod weight and application. Rods built with our reel seats and matching components become treasured showpieces and an extremely functional fishing tool that will last a lifetime. Gleaming nickel silver fittings coupled with select hardwood or cork spacers highlight this series. If you desire the finest, plan on building your freshwater rod with these components. Depending on the model, our nickel silver reel seats are provided with decorative knurling in 4 styles: Diagonal, Straight, Diamond, or our signature Rope pattern. All reel seats come standard with impregnated hardwood spacers. Natural hardwood or burl wood is offered as an option. Reel seats may be ordered with or without spacers. See Price List for options.

LOCKING MODELS

NBS *New!*

Lightweight reel seat featuring milled slide band and hood with double knurled nut. Recommended for #2-7 line weight rods. Diameter: 0.655" • Length: 3.450"

NBGB *New!*

Extremely lightweight reel seat featuring uniquely shaped milled slide, milled hood, single knurled nut with trim band. Butt cap features bullseye design. Recommended for #2-7 line weight rods. Diameter: 0.665" • Length: 3.450"

NBGS *New!*

Lightweight reel seat featuring uniquely shaped milled slide, milled hood, single knurled nut with trim band. Butt cap features REC's unique stepped design. Recommended for #2-7 line weight rods. Diameter: 0.665" • Length: 3.450"

NBM

Designed for the high volume rod builder / manufacturer seeking a high quality, light weight nickel silver reel seat at an attractive price. Features include a decorative double knurled nut, milled hood, and formed pocketed slide band. Recommended for #2-7 line weight rods. Diameter: 0.665" • Length: 3.450"

NSU

Uplocking design with skeleton barrel, butt cap, knurled nut (Diamond pattern only), plain slide band, fixed hood / cork check and mortised hardwood spacer. The NSU shares similar features with the very popular NSUS. Recommended for #5-8 line weight rods. Diameter: 0.720" • Length: 3.400"

Reel seats may be ordered with any available wood species. See price list for complete selection.



California Buckeye Burl - Diagonal Knurl



Spalted Maple Burl - Diagonal Knurl



Tiger (Fiddleback) Maple - Diagonal Knurl



Birdseye Maple - Diagonal Knurl



Maple Burl - Diamond Knurl

The South Island, New Zealand

Photo A. Gnann



River Test Native Brown

Photo A. Gnann



NSUS

Our "signature" reel seat and one of our most popular models. Uplocking design with skeleton barrel featuring a trim band, special butt cap, knurled nut, knurled slide band with fine trim lines, knurled fixed hood / cork check, and mortised hardwood spacer.

Recommended for #5-8 line weight rods. Diameter: 0.720" • Length: 3.500"

NSUSL

This smaller version of the NSUS meets the needs of those who wish to incorporate the features of an uplocking reel seat for light and super light rods. The hardware is identical to the NSUS above except that the reel seat is proportionally reduced in size and weight.

Recommended for #2-4 line weight rods. Diameter: 0.645" • Length: 3.400"

NSGX

An uplocking reel seat with the same features as the NSUS but with the addition of a decorative knurled butt cap. Four knurled parts in total.

Recommended for #5-8 line weight rods.

Diameter: 0.720" • Length: 3.500"

NSGXL

The hardware is identical to the NSGX above except that the reel seat is proportionally reduced in size and weight. *Recommended for #2-4 line weight rods.*

Diameter: 0.645" • Length: 3.400"

NSDS

A very popular downlocking reel seat with the same features, trim lines, and detail as the NSUS which share interchangeable parts except the butt cap which is unique to this model. The slide band, nut, cork check, and butt cap are each knurled.

Recommended for #5-8 line weight rods.

Diameter: 0.720" • Length: 3.900"

NSDSL

This smaller version of the NSDS was introduced to meet the needs of those who wish to incorporate the features of a downlocking reel seat for light and super light rods. The hardware is identical to the NSDS above except that the reel seat is proportionally reduced in size and weight. *Recommended for #2-4 line weight rods.*

Diameter: 0.645" • Length: 3.725"

CAP & RING MODELS

CRN "Catskill HLL Style"

Our most popular cap & ring model incorporating a double knurled "wedding ring" slide band, knurled butt cap, and knurled cork check. This model is favored by split cane and lightweight graphite rod builders. *Recommended for #4-7 line weight rods.*

Diameter: 0.720" • Length: 3.545" • Butt Cap I.D.: 0.720" • Slide Band I.D.: 0.730"

CRNS "Catskill HLL Style"

Same design and function as the CRN above only scaled down dimensionally for the ultimate in classic lightweight appeal. *Recommended for #0-4 line weight rods.*

Diameter: 0.650" • Length: 3.420" • Butt Cap I.D.: 0.650" • Slide Band I.D.: 0.665"

LCRN "Classic EFP Style"

An extremely lightweight model similar in proportion to the CRN. A special nickel silver alloy allows us to create a thin but strong slide band and cap. Available only with a very fine, recessed, straight knurl. Two fine trim lines are placed on the slide band and cap.

The cork check is knurled to match. *Recommended for #4-6 line weight rods.*

Diameter: 0.720" • Length: 3.520" • Butt Cap I.D.: 0.720" • Slide Band I.D.: 0.730"

LCRNS "Classic EFP Style"

Same features as the LCRN except sized similar to the CRNS.

Recommended for #0-4 line weight rods.

Diameter: 0.650" • Length: 3.400" • Butt Cap I.D.: 0.650" • Slide Band I.D.: 0.665"

PLRN

The lightest model featuring a round cork spacer, two knurled slide bands, knurled cork check and a nickel silver end plate suitable for engraving. *Recommended for #0-4 line weight rods.*

Diameter: 0.720" • Length: 3.700" • Slide Band I.D.: 0.730"



Amboyna Burl - Diagonal Knurl



Bocote - Rope Knurl



Cocobolo - Rope Knurl



Amboyna Burl - Diagonal Knurl



Cherry Burl - Rope Knurl



Maple Burl - Diagonal Knurl



Spalted Maple Burl - Rope Knurl



Tiger (Fiddleback) Maple - Diagonal Knurl



Tiger (Fiddleback) Maple - Fine Straight Knurl

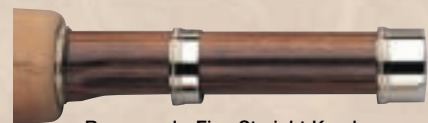

Rosewood - Fine Straight Knurl



Cork (Premium) - Rope Knurl

PLRW

This lightweight, uplocking model features a mortised spacer with a flared end, double knurled slide band, knurled hood, and nickel silver end plate suitable for engraving. Recommended for #1-4 line weight rods.
 Diameter: 0.650" • Length: 3.250" • Slide Band I.D.: 0.665"



Maple Burl - Rope Knurl

NGMD "Garrison Style"

"Garrison" style seat with REC's unique one piece formed pocketed NBD butt cap, matching knurled slide band and cork check, with round hardwood or cork spacer. All components are available separately. Recommended for #4-7 line weight rods.
 Diameter: 0.685" • Length: 3.700" • Butt Cap I.D.: 0.685" • Slide Band I.D.: 0.760"



Amboyna Burl - Diamond Knurl

CLASSIC SERIES - ANODIZED ALUMINUM

REC's aluminum reel seats enable you to build the perfect rod for any angling situation. All aluminum components are anodized to withstand rigorous military and industry standards which means our components will last a lifetime...in fresh or saltwater. They are available in your choice of Pewter, Black, Champagne, or "Nickel Silver" color. The nut, slide band and hood feature a functional decorative knurl.

Reel seats come standard with impregnated hardwood spacers. Select hardwood or burl spacers are optional.

LOCKING MODELS

AUS

Fine thread, skeleton uplocking design with mortised spacer. Same dimensions and general features as the NSUS except in aluminum. Knurled nut, slide band, and fixed hood / cork check. Recommended for #3-7 line weight rods
 Diameter: 0.715" • Length: 3.600"



Black Ash Burl (Dyed Green) - Champagne

AUSL

This reel seat is identical in features to the AUS except for a proportional reduction in size and weight. Recommended for #0-4 line weight rods. Diameter: 0.645" • Length: 3.450"

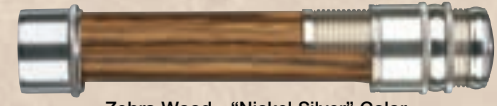

Zebra Wood - "Nickel Silver" Color

ABS New!

Lightweight reel seat featuring milled slide band and hood with double knurled nut. Recommended for #2-7 line weight rods.
 Diameter: 0.655" • Length: 3.450"



Curly Koa - "Nickel Silver" Color

ABGS New!

Lightweight reel seat featuring uniquely shaped milled slide, milled hood, single knurled nut with trim band. Butt cap features REC's unique stepped design. Recommended for #2-7 line weight rods. Diameter: 0.665" • Length: 3.450"

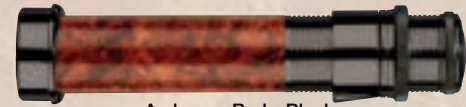

Amboyna Burl - Black

CAP & RING MODELS

CRA

Similar in dimension to the CRN, the CRA offers weight reduction through use of aluminum components. Features include finely knurled butt cap, slide band and cork check. Recommended for #4-6 line weight rods.
 Diameter: 0.720" • Length: 3.550" • Butt Cap I.D.: 0.720" • Slide Band I.D.: 0.730"



Maple Burl - "Nickel Silver" Color

CRAS

Identical in features to the CRA except for a proportional reduction in size and weight. Recommended for #0-4 line weight rods.
 Diameter: 0.650" • Length: 3.450" • Butt Cap I.D.: 0.650" • Slide Band I.D.: 0.665"



Spalted Maple Burl - Champagne

ENGRAVING

REC can engrave all flat and round metal surfaces using either our high resolution laser or precision diamond engraving machines. Both machines are capable of using a wide variety of standard fonts or your logo can be registered into our computer for that custom touch on butt cap ends or sides, slide band sides, or rod case end caps. Please contact us for custom engraving or refer to our price list for standard engraving options. Engraving available on flat surfaces or circumferences.

Call for details.

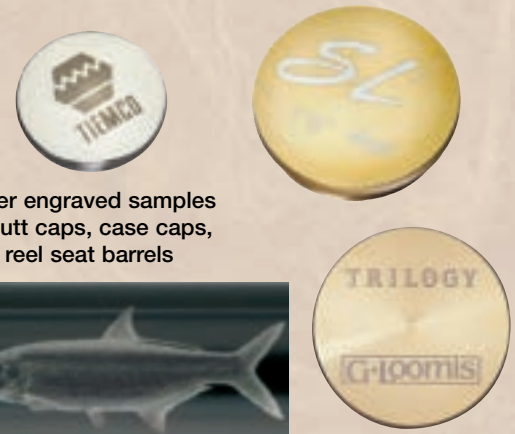

Laser engraved samples of butt caps, case caps, and reel seat barrels



Diamond Engraved



SALTWATER, STEELHEAD, SALMON, & SPEY ROD MODELS

USA

Our most versatile and popular saltwater reel seat. All aluminum, mortised barrel including twin knurled locking nuts with recessed O-rings, knurled milled slide band, and recessed milled fixed hood. Features unique hood and slide alignment grooves. Recommended for #7-11 line weight rods. Diameter: 0.750" • Length: 3.85"



Black - 1.5FVB

RGAL *New!*

Extremely light weight reel seat with round barrel, milled hood and slide band, twin knurled nuts with floating O-ring. Recommended for #7-11 line weight rods. Diameter: 0.750" • Length: 3.65"



"Nickel Silver" Color - 1.5FCR

RGAL-LAS *New!*

The RGAL reel seat available with a choice of laser engraved fish. See REC.com for pictures of the available choices. Recommended for #7-11 line weight rods. Diameter: 0.750" • Length: 3.65"



Black - 1.5FVB

RGML *New!*

Same as RGAL above except with wood spacer of your choice. For saltwater use we recommend either stabilized or impregnated woods. Recommended for #7-11 line weight rods. Diameter: 0.750" • Length: 3.65"



"Nickel Silver" Color (Tiger Maple) - 1.5FVB

RGMS *New!*

Same as RGML above except for a proportional reduction in size and weight. Recommended for #5-8 line weight rods. Diameter: 0.690" • Length: 3.325"



Black (Birdseye Maple)

RFTS *New!*

Features REC's TruTrak™ flat milled barrel (top), slide, and hood. Slide band and hood are always in perfect alignment for reel placement. Also prevents reel twisting for extra security. Reel fits on radiused surface with flat milled TruTrak on top. Recommended for #7-12 line weight rods. Diameter: 0.750" • Length: 4.000"



Black - 1.5FVB

RSLL *New!*

Economically priced saltwater reel seat featuring a round barrel, milled slide and hood, twin knurled nuts with recessed O-rings and cork trim ring. Uses fighting butt without metal insert. Recommended for #7-12 line weight rods. Diameter: 0.740" • Length: 3.670"



Black

RSLS *New!*

Same as RSLS above except for a proportional reduction in size and weight. Recommended for #5-8 line weight rods. Diameter: 0.630" • Length: 3.725"



Black

SWRS

All aluminum, uplocking large diameter (I.D.=0.765"), saltwater and Spey rod reel seat with formed pocketed hood, slide band, and double locking nuts. Fits any reel foot. Recommended for #9-13 line weight rods. Diameter: 0.870" • Length: 4.700"



Pewter

SWAU

Heavy duty large diameter, uplocking reel seat with a hardwood spacer (Bore=0.500"), precision milled hood, slide band, and two double knurled locking nuts. Available in Impregnated Walnut or Impregnated Rosewood only. Recommended for #10-14 line weight rods. Diameter: 0.845" • Length: 5.150"



Impregnated Walnut - Black

SPGE

All aluminum reel seat with a round barrel (I.D.=0.765"), precision milled hood and slide band, O-ring, and two double knurled locking nuts. Recommended for #10-15 line weight rods. Diameter: 0.870" • Length: 4.750"



Pewter

FIGHTING BUTT OPTIONS

Available in fixed or removable styles with either cork/composite rubber cork (round or flat design) or cork/EVA. Specify reel seat when purchased separately. Any fighting butt shape is available without aluminum fixtures. For use with: NSU, NSUS, AUS, USA, RGML, RGAL, and RFTS.



1.0 FCF



1.0 FCR



1.5 FCF



1.5 FCR



1.5 FVB



1.0 RCF



1.0 RCR



1.5 RCF



1.5 RCR



1.5 RVB

Hardwood Spacers

REC offers an extensive selection of hardwood spacers. Our spacers are handcrafted and inspected for precise metal to wood fit, and finish. In general, REC spacers are given several coats of a natural oil finish which ensures that the wood is protected from the elements beyond a mere surface finish. This finishing method allows the spacer to be touched up to the original luster after extended use. Our hardwood is hand selected for consistent color, exceptional grain, and beautiful figure. Our impregnated woods are custom produced to REC's specification for color, strength, and density. Exotic and impregnated woods are hand buffed using natural oils only. Select burl woods are available in many species and shades and are generally stabilized under pressure with acrylic resin.

Depending on the reel seat design, spacers are machined in either a mortised, round, or oval configuration. Note the exceptional reel foot fit on each type due to REC's extra attention to detail in the contouring of our spacers. Regardless of the design selected, you can be assured of a positive rod to reel connection - every time. Standard spacer bore is 0.375" or 0.312" depending on the reel seat. Custom boring is available.

(All natural woods vary in shade and figure. Use photos below for guidance only.)

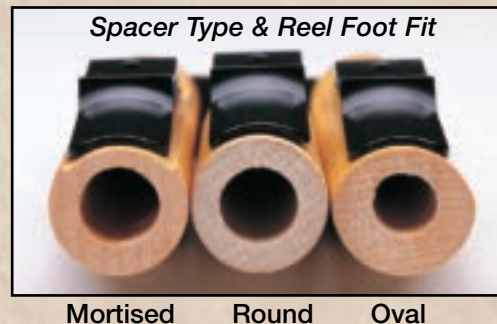

Mortised Round Oval

IMPREGNATED HARDWOOD

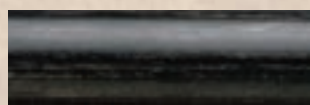

Impregnated Charcoal

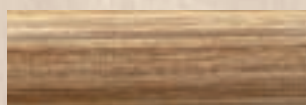

Impregnated Chestnut



Impregnated Cocobolo

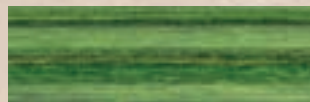

Impregnated Emerald



Impregnated Walnut



Impregnated Rosewood

NATURAL HARDWOOD



Birdseye Maple



Rosewood



Bocote



Spanish Cedar



Cocobolo



Tiger (Fiddleback) Maple



Curly Koa



Tulipwood

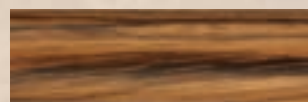

Zebra Wood

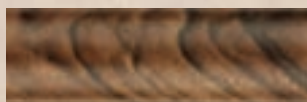

Walnut (Highly Figured)

NATURAL BURL HARDWOOD

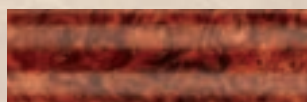

Amboyna Burl



California Buckeye Burl



Black Ash Burl



Cherry Burl



Black Ash (Dyed Green)

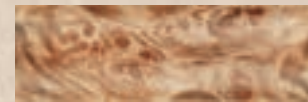

Maple Burl



Box Elder Burl

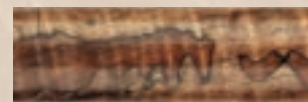

Spalted Maple Burl



LASER ENGRAVED SPACER:
REC can laser engrave your name, logo, etc. Call for details.

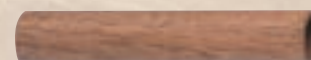

FILLER: Optional hardwood filler for aluminum reel seats to provide firm bonding. Specify reel seat.



REC Introduces a Revolutionary New Material



RECOIL FLY ROD GUIDES AND TIP TOPS

RECOIL® guides are made from a special Nickel Titanium alloy with unique physical properties which provide exciting new possibilities for rod designers worldwide. Until now, rod guides have been plated or have used ceramic inserts to provide wear resistance. RECOIL guides are made from an extremely hard but flexible "Shape Memory" alloy, which does not require plating, cannot corrode in any environment, and returns to its original shape after repeated deformations. Some of the features and benefits derived from the use of RECOIL guides are:

- RECOIL guides are extremely light (60-70% lighter than conventional snake guides).
- RECOIL guides cannot corrode in any environment. First truly corrosion proof guide.
- Rod action is significantly enhanced and tip speed is greatly increased.
 - Guides flex with rod / No flat spots
 - Higher line speed
 - Improved casting distance
- Guide feet are swaged flat and pre-ground for smooth thread transition.
- Tip tops (RTT) are available in sizes 3.5 through 6, standard (S), large (L), and extra large (XL) loop diameters.

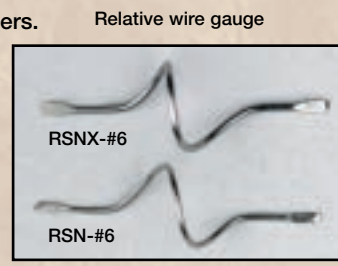
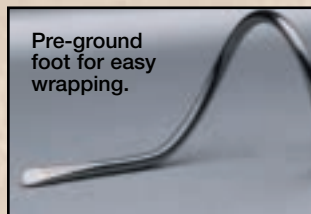

- RECOIL guides are available in two wire diameters.
 - Snake guides (RSNX) and Single foot guides (RSFX) for moderate to heavy rods/saltwater use. (Line weights 4 and above)
 - Snake guides (RSN) and Single foot guides (RSF) for light duty freshwater use. (Line weights 3 and below)
- RECOIL guides are currently available in the following configurations for fly rods:

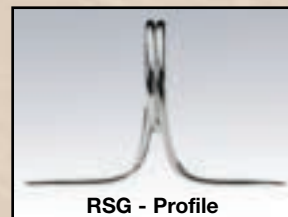
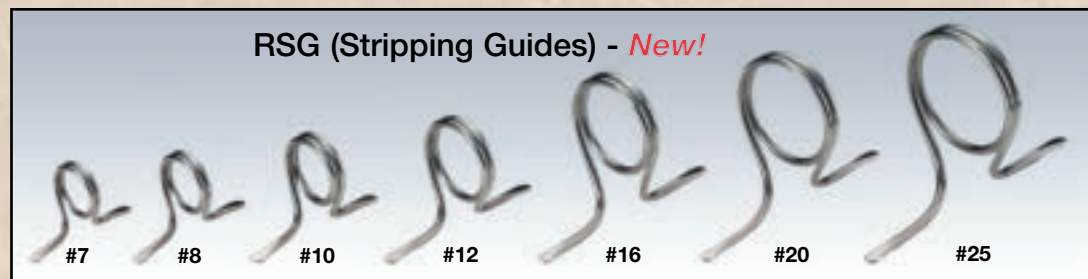
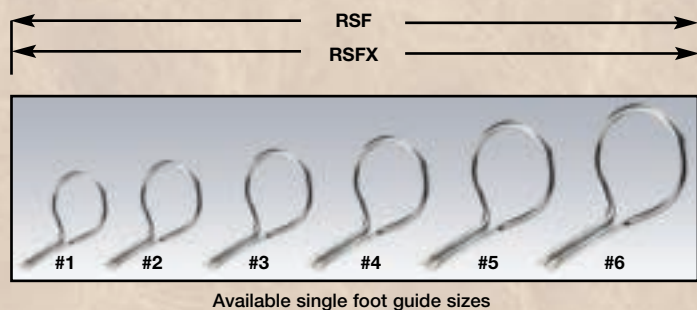
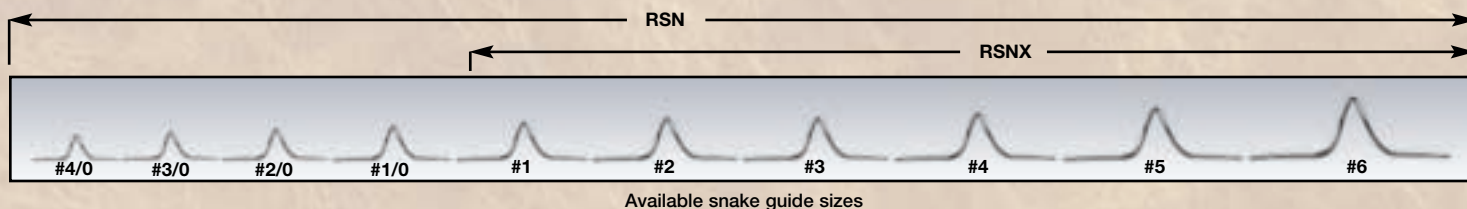

4 to 5 times lighter than ceramic guides • absolutely rust proof



for Fly and Spinning Rod Guides and Tip Tops

SPINNING ROD GUIDES AND TIP TOPS

RECOIL Guide Features:

- 4 to 5 times lighter than ceramic guides
- **Absolutely** rust proof
- Extremely durable - withstands repeated abusive deformation
- Extremely smooth micro-finish
- Extremely hard and wear resistant - no need for ceramic rings
- A pure alloy - no coating to wear or chip off
- Feet are preground - ready to wrap
- Guide sizes are comparable to conventional sizes

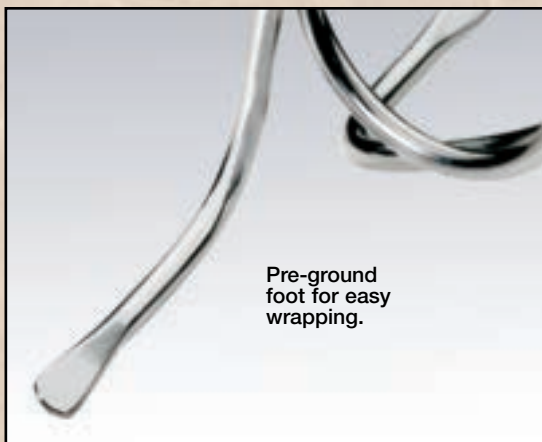
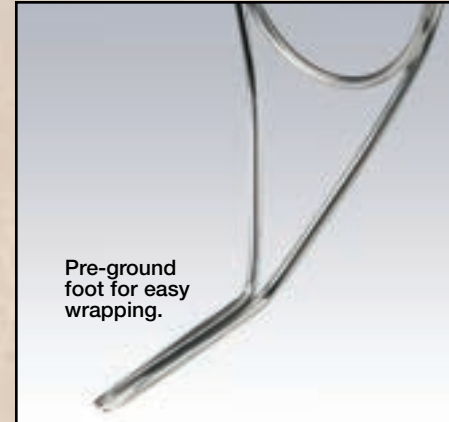

SPINNING AND CASTING REEL SEAT MODELS

SPN780

A 0.780" O.D. spinning rod reel seat with TruTrak™ barrel, slide, and hood system.
 Diameter: 0.780" • Length: 4.700"



Champagne

SPN875

A 0.875" O.D. spinning rod reel seat with TruTrak™ barrel, slide, and hood system.
 Diameter: 0.875" • Length: 4.700"



Pewter

SPC780

A 0.875" O.D. spinning or casting rod reel seat with TruTrak™ barrel, slide, and hood system. Incorporates a wood spacer (Impregnated Rosewood, Chestnut, or Cocobolo only).
 Diameter: 0.875" • Length: 4.700"



Black - Impregnated Rosewood

SMX780

A 0.780" O.D. spinning or casting rod reel seat with TruTrak™ barrel, slide, and hood system. Incorporates a double milled wood spacer (Impregnated Rosewood, Chestnut, or Cocobolo only).
 Diameter: 0.780" • Length: 4.700"



Black - Impregnated Chestnut

DBX780

A 0.780" O.D. spinning or casting rod reel seat with TruTrak™ double barrels, slide, and hood system. Incorporates a double milled wood spacer (Impregnated Rosewood, Chestnut, or Cocobolo only).
 Diameter: 0.780" • Length: 4.700"



Black - Impregnated Rosewood

ABX780

A 0.780" O.D. spinning or casting rod reel seat with TruTrak™ double milled barrel, slide, and hood system. Incorporates a double milled wood filler (Impregnated Rosewood, Chestnut, or Cocobolo only).
 Diameter: 0.780" • Length: 4.700"



Pewter - Impregnated Cocobolo

PNA780

A 0.780" O.D. all aluminum spinning or casting rod reel seat with TruTrak™ barrel, heavy duty slide and hood system. Features attractive and functional milled locking nuts.
 Diameter: 0.780" • Length: 4.700"



Pewter

PNA875

A 0.875" O.D. all aluminum spinning or casting rod reel seat with TruTrak™ barrel, heavy duty slide and hood system. Features attractive and functional milled locking nuts.
 Diameter: 0.875" • Length: 4.700"



Pewter

SBD780

A 0.780" O.D. adjustable spinning rod reel seat with TruTrak™ double barrels and slides. Adjustable features allow angler to place reel in perfect balance with the rod. Incorporates a wood spacer (Impregnated Rosewood, Chestnut, or Cocobolo only).
 Diameter: 0.780" • Length: 4.700"



Pewter - Impregnated Rosewood

SPINNING AND CASTING FORE AND REAR GRIPS

RG975

Spinning and casting rear grip - 9.750" x 0.500" Bore
 A-Grade cork



FG250

Fore Grip 2.500" x 0.375" Bore
 A-Grade cork

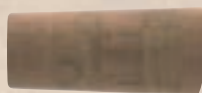

FG325

Fore Grip 3.250" x 0.375" Bore
 A-Grade cork

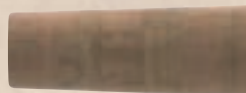

FG400CB

Fore Grip 4.000" x 0.375" Bore
 Counter Bored to accept reel seats:
 SPN780, SPC780,
 ABX780, SMX780 - A-Grade cork

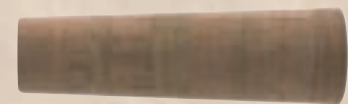

10

Cork Grips and Individual Rings

The cork grip provides the only connection between the angler and the rod. Therefore, a well shaped, ergonomically designed grip made from high grade Portuguese cork is essential to high quality rods. The foundation of a good grip is cork specifically graded for fishing rod grips. REC has ensured its supply of large quantities of high grade cork rings and pore-filled preformed grips by entering into a long term partnership with a leading manufacturer in Portugal.

Quality cork rings have few voids, well sanded perfectly parallel sides, and concentric bores. Well made cork grips are perfectly shaped, pore filled, sanded smooth, and have concentric bores. All REC cork products meet these criteria.

REC produces fly rod grips in six standard styles in the two highest grades only (Flor-Highest, Super-Next Best).

REC offers natural, rubber cork, and burl cork rings in a number of sizes. Natural cork rings are offered in three grades.

Flor grade represents 4 to 5 % and Super grade represents 12 to 15% of the annual harvest.

GRIPS



Standard Style



Cigar Style



Western Style



Half Wells Style



Full Wells Style



Fore Grip - 13.5"

Spey Style (Sold as a set)



Butt Grip - 5.5"

INDIVIDUAL RINGS

CORKS Super Grade



1 1/4" x 1/2" x 1/4" Bore

CORKF Flor Grade



1 1/4" x 1/2" x 1/4" Bore

CORK18UB Flor Grade



1 1/8" x 1/4" x Unbored

CORK18 Flor Grade



1 1/8" x 1/2" x 1/4" Bore

CORK14 Flor Grade



1 1/4" x 1/4" x 1/4" Bore

CORK14UB Flor Grade



1 1/4" x 1/4" x Unbored

CORKFUB Flor Grade



1 1/4" x 1/2" x Unbored

COMPR - Rubber Cork



1 1/4" x 1/2" x 3/8" Bore

COMPBRL - Burl Composite



1 1/4" x 1/2" x 3/8" Bore

1 1/4" x 1/2" x Unbored

Various colors

MILLED RINGS

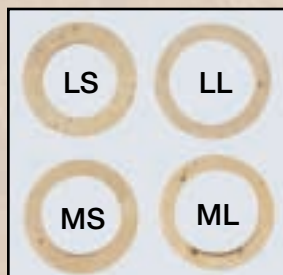
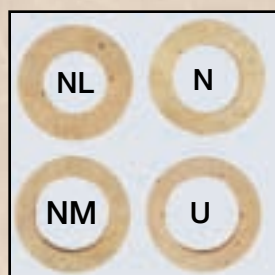

- CORK-NL (I.D. = 0.690")
For use with NSUSL, AUSL, NSGX, PLRW
- CORK-N (I.D. = 0.750")
For use with NSUS, NSU, NSGX, AUS
- CORK-NM (I.D. = 0.810")
For use with NBM, NBS, NGBG, NBGS
- CORK-U (I.D. = 0.830")
For use with USA

- CORK-LS (I.D. = 0.800")
For use with RSLS
- CORK-MS (I.D. = 0.880")
For use with RGMS
- ML (I.D. = 0.930")
For use with RGML
- LL (I.D. = 0.920")
For use with RSLL



Nickel Silver and Aluminum Components

UNI-FERRULES™ A SIGNIFICANT IMPROVEMENT IN FERRULE DESIGN

REC precision machines its uni-ferrules from solid 18% nickel silver bar stock. This means **no silver soldered joints to fail** or impede oxidation (bluing). Features include an elegantly designed welt, distinctive double trim lines, and six serrations. 60 rated RMS finish on cane engagement surfaces to promote adhesion and 16 rated RMS micro finish on all mating parts (super smooth). All ferrules are machined to extremely close tolerances. Final fitting takes approximately 20 minutes. Available in single or double male sets. Standard lengths in sizes 9/64ths to 20/64ths. Truncated lengths in sizes 9/64ths to 18/64ths. **Weight is identical to ferrules made from tubing.** Field tested for over 5 years without a single failure.

Unconditionally guaranteed.

Cross section showing solid bar stock construction

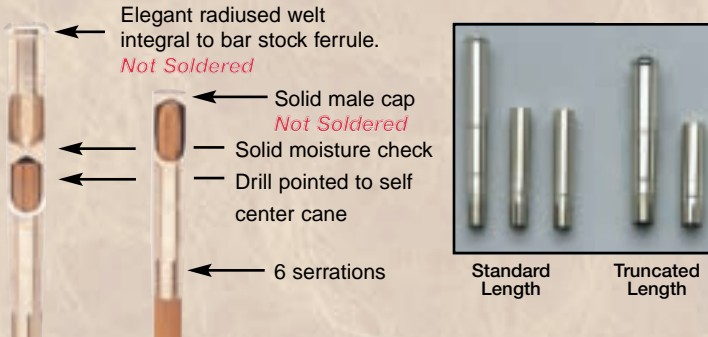

WINDING CHECKS

REC offers a wide range of winding checks sized in 1/64th" increments (Inside Diameter). Nickel silver winding checks are available in a stepped "plain" style or knurled with a diagonal, straight, or rope pattern. Aluminum winding checks are anodized in colors to match our standard components. Our nickel silver hexagonal winding checks were introduced to meet the needs of the split cane and hexagonal graphite rod makers. The inside diameter is machined in a hexagonal shape to precisely fit the rod flats. (Measure flat to flat for sizing.)

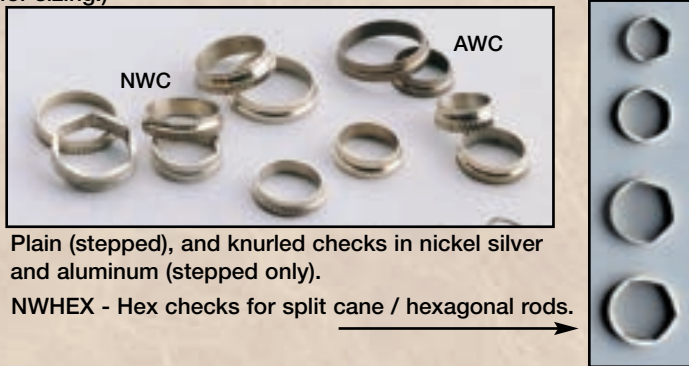

Plain (stepped), and knurled checks in nickel silver and aluminum (stepped only).

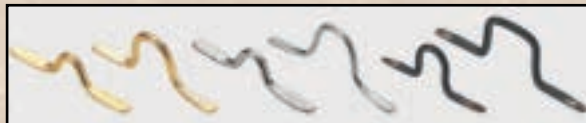

PHK - Wire Frame Hook Keepers
Shown in Gold, Chrome, and Black
Sizes Small & Large



NHK - Folding Hook Keeper with
Nickel Silver Ring

GUIDES AND ROD MOUNTINGS

REC offers a wide range of guides and tip tops including classic Mildrum Tungsten Carbide stripping guides and tip tops. Guides and tip tops manufactured by other suppliers such as Fuji®, Snake Brand™, Hopkins & Holloway®, and Perfection® are also available.

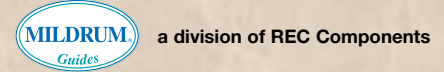

Snake guides and tip tops - available colors: chrome, gold, black

FUJI™ STRIPPING GUIDES



BLNAG
with Alconite Ring



CLNAG
with Alconite Ring



BNLG
with Alumina Ring



NLG
with Alumina Ring



NSG
with Silicon Carbide Ring

Snakes available in Chrome, Black, and Bronze. Tip Tops available in Chrome & Black only.

SNAKE BRAND GUIDES

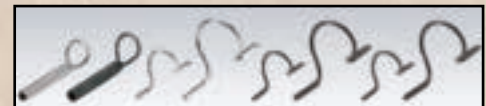

THREADS, COATINGS, AND SUPPLIES

Other than blanks, REC offers all products and accessories required to build rods. REC distributes a full selection of Gudebrod® silk and nylon winding threads. See our web site "www.rec.com" for a chart of all available colors. REC also distributes all FlexCoat® products to include adhesives, wrap finishes, color preservers, brushes, and rod wrapping stands / machines.





ROD CASES

ADVANCED TECHNOLOGY • DESIGN SOLUTIONS • QUALITY • TRADITION • SINCE 1968

Rod Cases

REC's reputation for quality is built on over 30 years of adherence to the highest manufacturing standards while using the best available materials and finishing processes. All aluminum rod cases are manufactured from hard drawn, high strength, lightweight aircraft grade tubing (wall thickness = 0.035"). REC offers aluminum cases in 5 diameters (outside). To determine inside diameter subtract 0.070". For instance, the inside diameter of a 2" case is 1.93". This wide range of tube diameters offers anglers the opportunity to protect almost any rod. REC rod cases are engineered to ensure functional, durable, and lasting protection for fishing rods while enhancing the perceived value of the contents. Our continual improvement in product design, materials, and aesthetic enhancements guarantees that REC's rod cases are the best available. All REC products are 100% made in the USA.

HOW TO SPECIFY A REC ROD CASE:

1. DETERMINE CASE LENGTH

Measure the length of the longest rod section. We recommend adding 1 1/2" to measured length to accommodate a rod bag and ensure sufficient interior space. The interior length of all REC cases is exactly as specified and is measured from the bottom to the tube-collar interface. If the section length cannot be determined when ordering, divide the overall rod length in inches by the number of sections and add 2 1/2" to accommodate the ferrules. Note: The additional 2 1/2" length is required to accommodate normal ferrule length for rods under 12 feet, assembled. Add 3 1/2" for rods 12 feet and over.

2. DETERMINE REQUIRED DIAMETER

Two piece freshwater rods can ordinarily be cased in 1 5/8" tubes. Saltwater, Spey and multipiece rods are ordinarily cased in 2", 2 1/4", 2 1/2", & 3" diameter tubes. Please allow room for the rod bag, over size guides, and fighting butts. Note: Every REC rod case incorporates our exclusive CaseLock™ bottom system to ensure the security of case contents. Specify rod case by indicating the product designation code (SKU) followed by the appropriate length in inches.

Example: RCB 38.5 (indicates 2" diameter x 38.5" interior length.)

Available rod case diameters and associated product designation

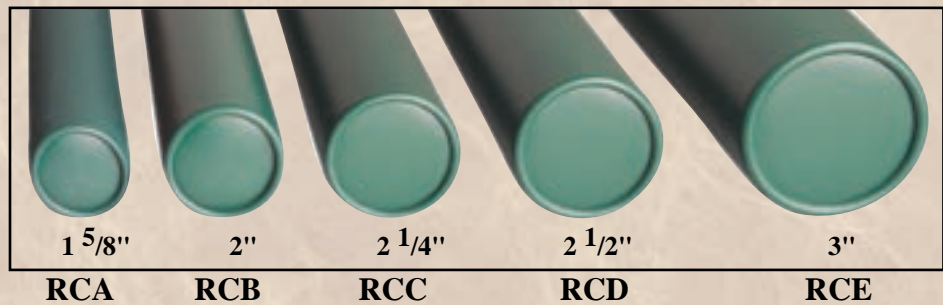

REC rod cases featuring unique CaseLock™ bottoms

3. SPECIFY TUBE TREATMENT

REC offers three types of aluminum tube treatments: Brushed, Anodized, and Powder Coated in many attractive standard colors. The brushed aluminum tubing is economical, yet attractive in a traditional style. The bronze anodized tubes are favored by many rod makers in combination with REC's Heritage™ Brass hardware for presentation quality rod cases. Our powder coated tubes are highly resistant to abrasion, UV light, saltwater, gasoline, and DEET (insect repellent) to ensure lifetime use in demanding conditions. Powder coated surfaces (except Mineral Bronze) are textured to enhance the beauty of the case and prevent scuffing.

Special colors available on request and subject to production minimums.

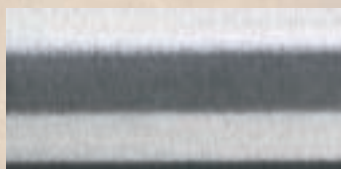

Brushed Aluminum - BRU

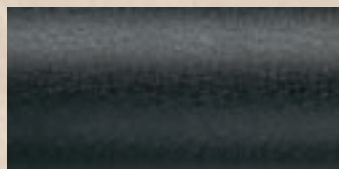

Tuxedo (Textured) - PCT

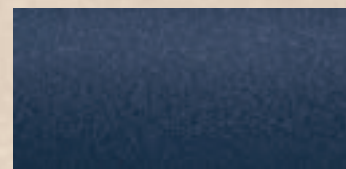

Ocean (Textured) - PCO

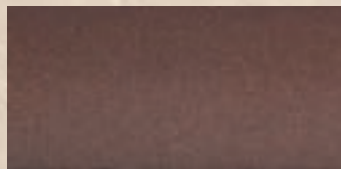

Mineral Bronze (Smooth) - PCZ

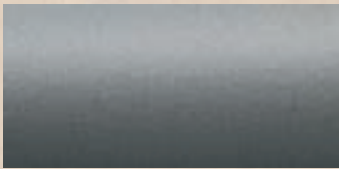

Gray (Textured) - PCG



Moss (Textured) - PCM

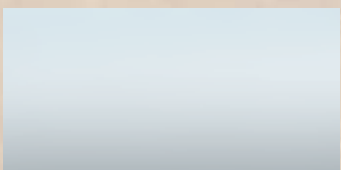

Silver (Smooth) - PCA



Forest (Textured) - PCF

4. SPECIFY HARDWARE TYPE

REC offers several hardware options for rod cases. Aluminum case hardware is machined from aircraft grade aluminum and anodized to military specifications to ensure durability in the harshest environments. Aluminum caps and bottoms are machined from solid barstock. Aluminum hardware anodized in Clear, Gold, Pewter, Black, and Champagne colors. Heritage™ Brass case hardware is precision machined from solid bar stock and hand polished to a brilliant luster.

STANDARD

New and improved design incorporates a heavier, easy threading cap with more pronounced knurling for better grip, overall increase in collar length, and a flared collar end giving it a more elegant look. Interior cushion and O-ring included. Offered in Clear, Pewter, Gold, Champagne, and Black. Optional decorative bottoms available.



Standard - Champagne

VENTSEAL™

Unique REC ventilated cap & collar system allows storage of wet rods without risk of damage. Cap & collar may be oriented to either seal or ventilate case with unique dual thread technology (directions included). Offered in 1 5/8", 2", and 2 1/4" diameters. Offered in Pewter, Gold, and Champagne colors. Optional decorative bottoms available.



VentSeal - Gold

CLASSIC™

Elegant cap, collar, and bottom system. Features include precision radiused sides, distinctive raised trim lines, and finely knurled cap. Offered in 1 5/8", 2" and 2 1/4" diameters. Offered in Pewter, Gold, and Champagne colors. Optional decorative bottoms available.



Classic - Pewter

HERITAGE™ BRASS

REC's signature brass cap, collar, & optional bottom are machined from solid bar stock and detailed with dual trim lines and smooth radiused edges. Hand polished and buffed to a brilliant luster. Design is similar to the classic hardware used by rod makers in the early 1900's. Appropriate for "Presentation" quality rods. Offered in 1 5/8" and 2" diameters.



Heritage Brass

5. SPECIFY OPTIONAL CUSTOM CAP ENGRAVING

REC can customize rod case caps with either laser or diamond engraving. Both technologies have the ability to reproduce a wide range of fonts and logos. (Call for assistance regarding set up and art requirements or see price list).



Diamond Engraved Caps

6. SPECIFY OPTIONAL PRINTED LOGOS

Custom Printed logos permanently applied to rod cases. Paint is thermally cross linked during application which means it will never chip, fade, or peel. Single or multicolor printing available in any PMS or custom color. Minimum order quantity - 25 cases. REC also offers the option of custom adhesive labels. Call for assistance regarding set up charges and art requirements.



Laser Engraved Aluminum Caps

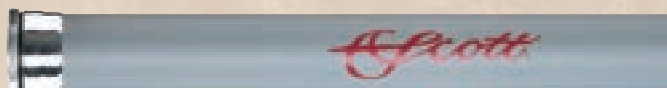

Standard Clear hardware, custom colored logo.

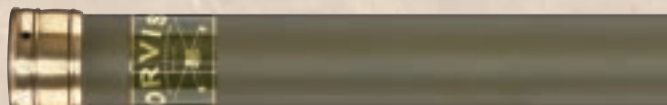

VentSeal Gold hardware, Custom adhesive label.

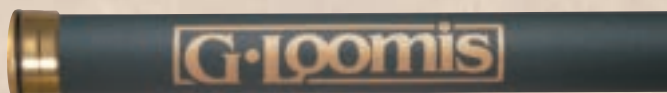

Standard Gold hardware, Gold logo.

ROD BAGS

7.5 ounce blended twill fabric. Available in a variety of colors and sizes.



REC Components...A Reputation You Can Build On

Providing Component and Case Solutions to Rod Manufacturers Worldwide Since 1968

REC routinely engages in partnering relationships with leading manufacturers and commercial custom rod builders worldwide. REC can design and manufacture rod component and rod case packages with limited or detailed input from the customer. REC will provide full working CAD (Computer Aided Design) drawings and working prototypes for approval prior to production. Depending on the extent of the product design contribution and the size of the program, REC may offer the resulting product on an exclusive basis for a specific time frame.

Regardless of the scope of the program REC treats each project in an extremely confidential manner.

REC manufactures only rod components and rod cases. Our design engineers and production personnel are extremely familiar with the essential aspects of a well coordinated rod component program and the importance of efficient rod assembly. In addition to design and manufacturing skills, all of our key engineering, production, and customer service personnel are avid anglers thus bringing a wealth of knowledge and experience to our customers. Please contact REC to discuss your rod components and case needs.

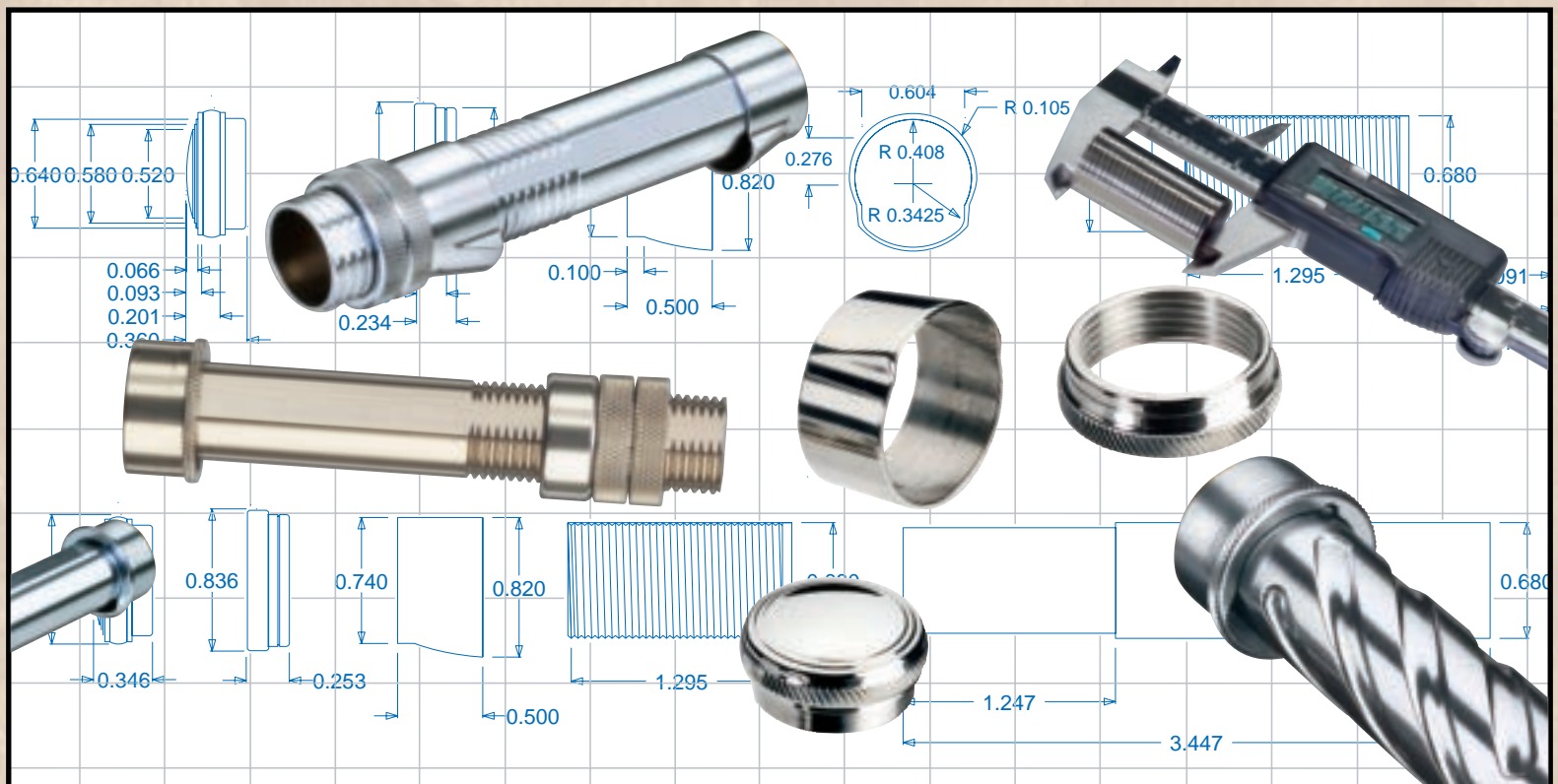

Photo A. Gnann
Deschutes River, Oregon

Conservation

REC promotes catch and release angling and supports those organizations which advance the preservation of our fisheries and angling habitat. Each year, a portion of our earnings will be channeled to such organizations.



REC Components

17 Middle River Dr, Stafford Springs, CT 06076
Tel: 860-749-3476 • Fax: 860-749-3478
info@REC.com • www.REC.com

FINE ROD COMPONENTS AND CASES

Demand the Best!

a division of:

EdgeWater International, Inc.