

# QuickStand™ Eco

## INSTALLATION INSTRUCTIONS

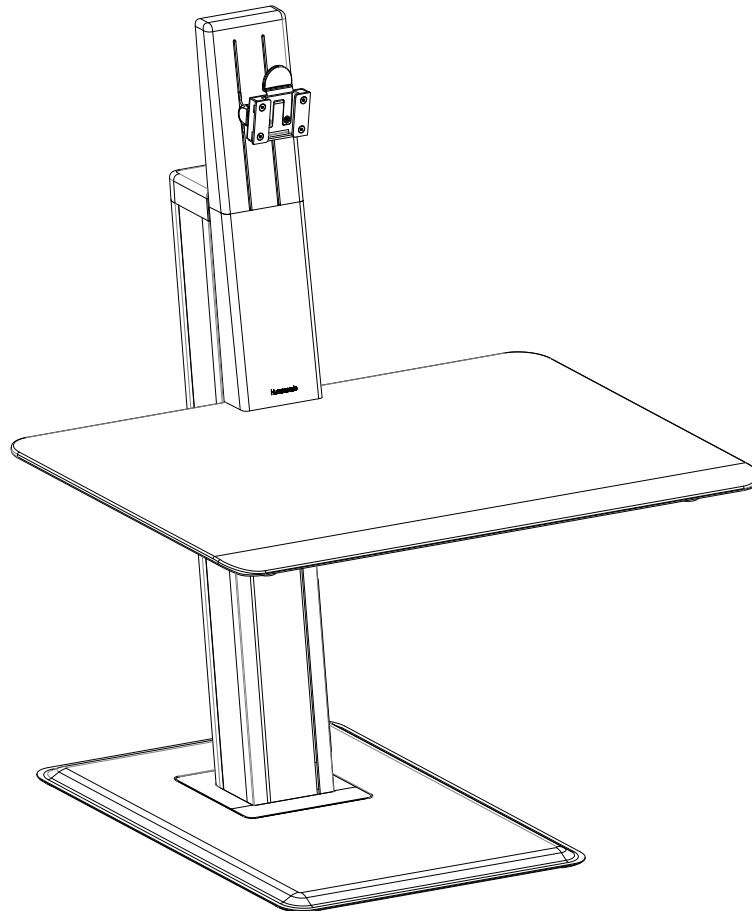

North America: +1 800 400 0625  
Europe: +353 (0)1 858 0910  
Asia Pacific: +852 2581 0570

Humanscale®

# PARTS AND TOOLS INCLUDED

(package contents will depend on configuration ordered)

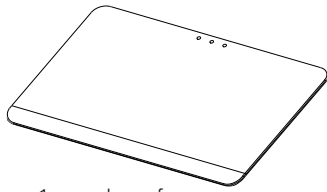

1x work surface

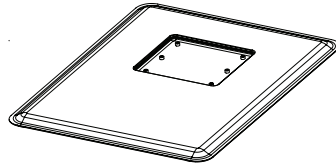

1x base

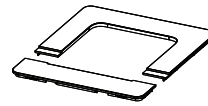

1x base plastic covers

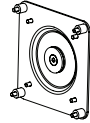

1 or 2x VESA plate(s)

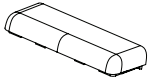

1x plastic cover  
(laptop only)



1x plastic cover  
(single and dual only)



1x plastic cover  
(single and dual only)

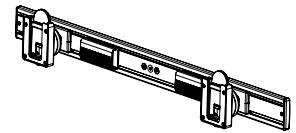

1x crossbar  
(dual monitor configuration only)

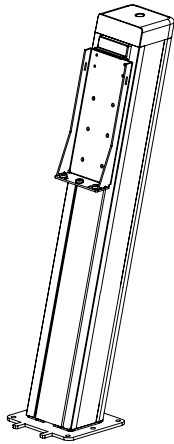

laptop

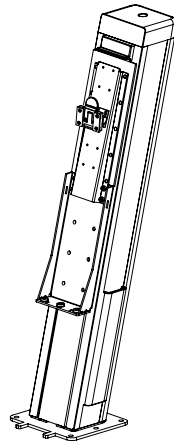

single monitor

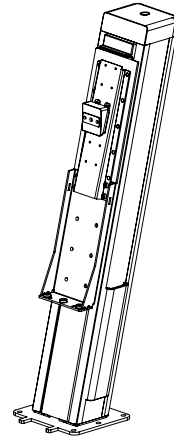

dual monitors

1x main post

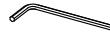

1x 2.5 mm hex key

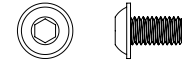

2x M8 21mm screw



4x M4 8mm screw  
(VESA hardware kit)

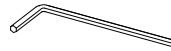

1x 6 mm hex key

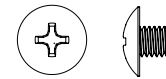

6x M6 6mm screw



2x M5 17mm screw  
(only with crossbar)

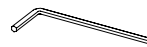

1x 3 mm hex key  
(only with crossbar)



4x M4 18mm screw  
(VESA hardware kit)



1x M6 17mm screw  
(only with crossbar)

# TOOLS NEEDED FOR ASSEMBLY

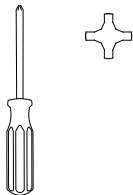

Phillips head screwdriver

## STEP 1

---

- Place the base on a desk. Remove the plastic covers and set them aside.

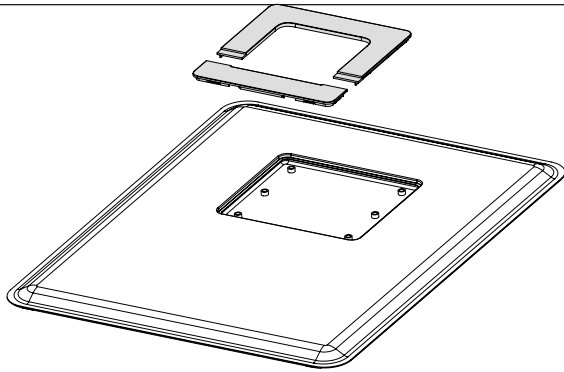

## STEP 2

---

- Slide the main post onto the base by inserting the 2 tabs in the front and secure the main post with 6 screws.
- Snap on the plastic covers removed in step 1. Rear cover first, then front cover.

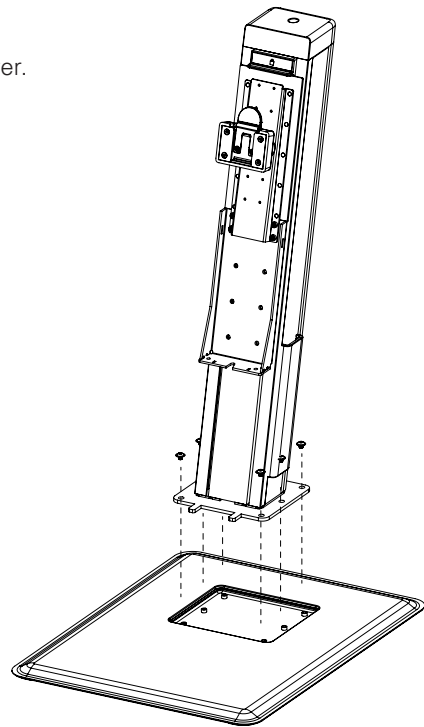
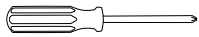
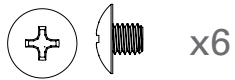

## STEP 3

---

- Slide the work surface, with preinstalled screw, into the slot in the support bracket. This will allow you to support the work surface with one hand and use your other hand to insert and secure the other two screws.
- Tighten all three screws securely with the 6mm hex key.

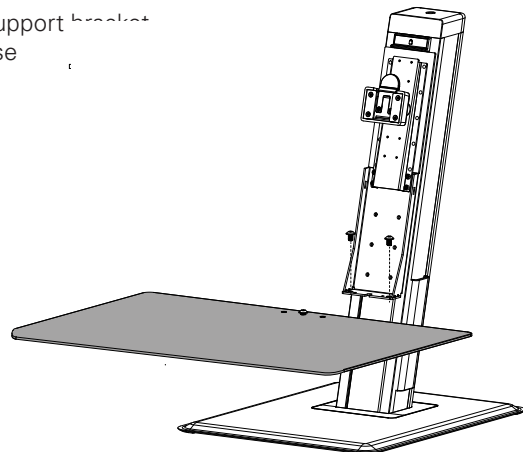
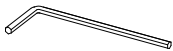
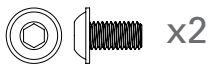

## STEP 4

- Attach the VESA plate onto the monitor(s).

 x4

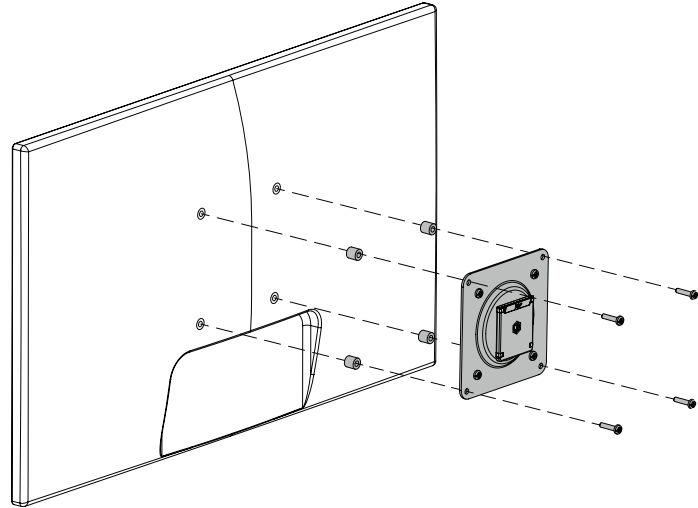
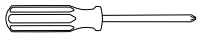

## STEP 5

- Reposition the 4 monitor height screws if necessary. Refer to the chart for recommended screw location.
- To adjust position, loosen the 4 screws shown here with the 2.5mm hex key. Lift and pull to remove the monitor mount off the unit. Relocate the screws to the desired hole numbers, replace monitor mount and tighten the screws.

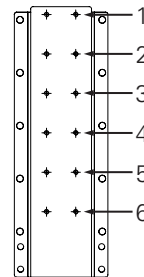
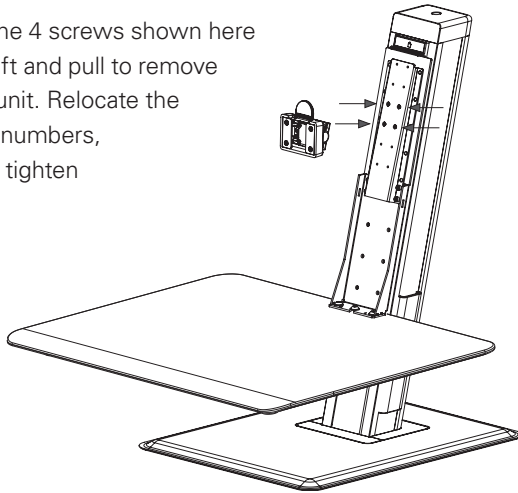

User Height (cm/ft)	Use hole numbers
190cm / 6'-3"	1 & 2
180cm / 5'-11"	2 & 3
175cm / 5'-9"	3 & 4
170cm / 5'-7"	4 & 5
165cm / 5'-5"	5 & 6

## STEP 6 (FOR SINGLE MONITOR)

- Attach the monitor to the unit by sliding the VESA plate tab in from the top.

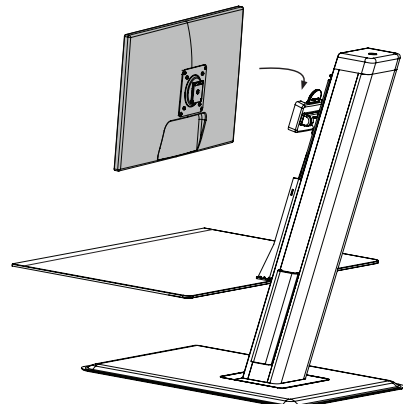

## STEP 6A (FOR DUAL MONITORS)

- Attach the crossbar to the unit using the 3 screws as shown.
- Attach both monitors to the crossbar.  
Refer to the crossbar installation manual.

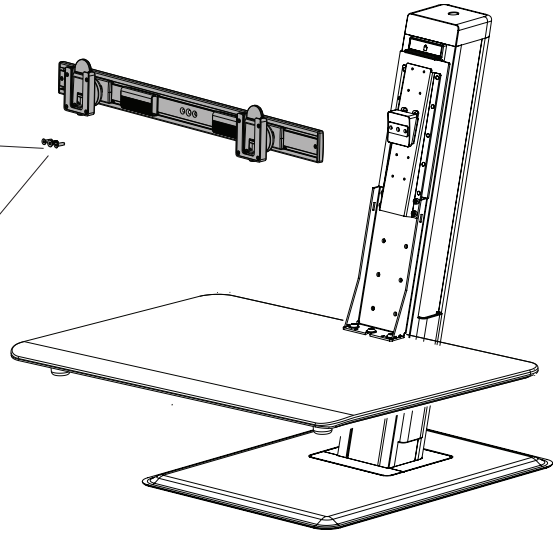
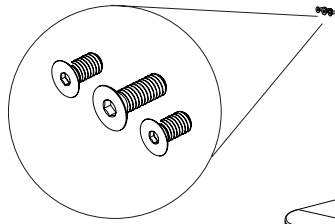
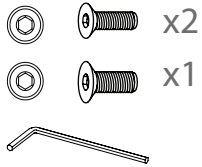

## STEP 7

- Push the keyboard platform down to remove the lock piece.

**WARNING:** PINCH POINT POTENTIAL!  
KEEP FINGERS CLEAR  
DURING OPERATION

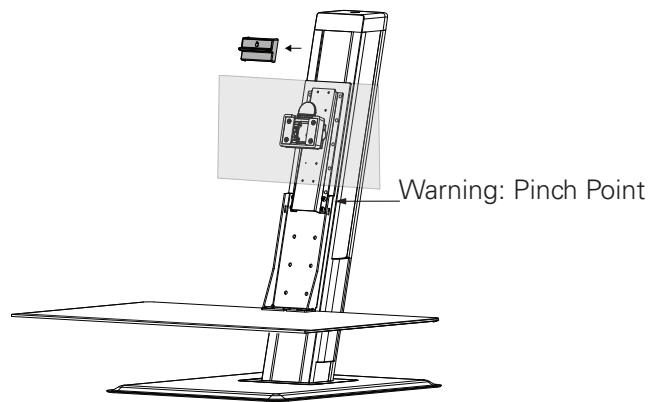

## STEP 8

### Attach the plastic covers

- Make sure the tabs on the lower plastic cover slide into the slots in the bracket (see arrows).
- The upper cover slides down from the top, behind the monitor mount bracket.

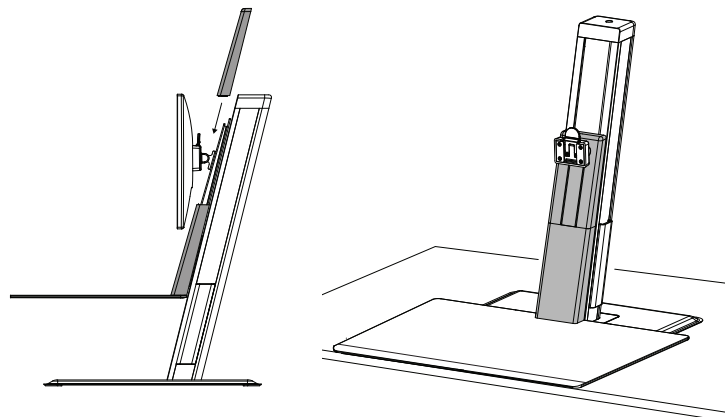
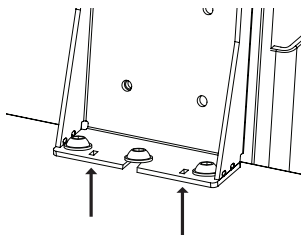

## STEP 9

### Adjust the counterbalance system

- Before making any adjustments to the tension, check to see if an adjustment is needed.
- After you have installed all of your peripherals (ie. laptop on surface and/or you have installed your monitor(s), keyboard and mouse), test the balance of the surface. By grabbing both side edges of the work surface you should be able to seamlessly raise and lower the platform.
- If the work surface holds its position after you move it — meaning that you don't feel the platform attempting to raise or lower on its own — then no tension adjustment is needed.
- If the surface does move upward or downward after you change position, then refer to the information on the next page.

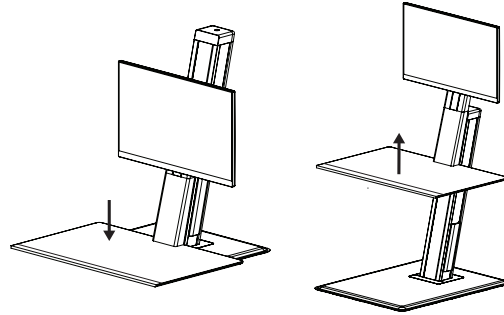

## STEP 9 (CONTINUED)

### Scenario A:

Surface lowers on its own without assistance, or lowers when you place your hands on the keyboard.

- Place the 6mm hex key into the adjustment screw on the top of the column. Turn the adjustment screw clockwise until the platform holds position and feels balanced while raising and lowering the work surface.

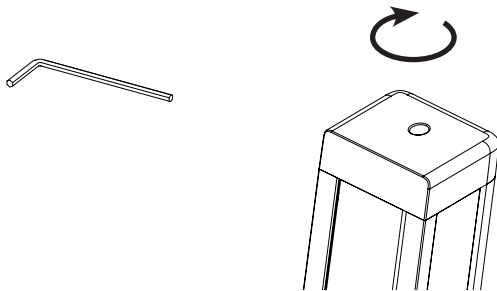

### Scenario B:

Surface raises on its own or is difficult to lower.

- Place the 6mm hex key into the adjustment screw on the top of the column.
- Turn the adjustment screw counterclockwise until the platform holds position and feels balanced while raising and lowering the work surface.

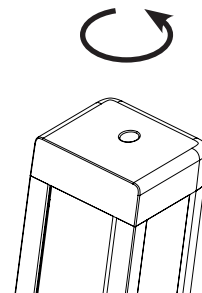

Humanscale®

humanscale.com

For our terms and conditions please go to  
<https://www.humanscale.com/about/legal-information/terms-conditions.cfm>

© 2019 Humanscale Corporation. The text and artwork are copyrighted materials. All rights reserved. The Humanscale mark and logo are trademarks of Humanscale Corporation and are registered in the United States and certain other countries. The Quickstand Eco trademark is owned by Humanscale Corporation.