

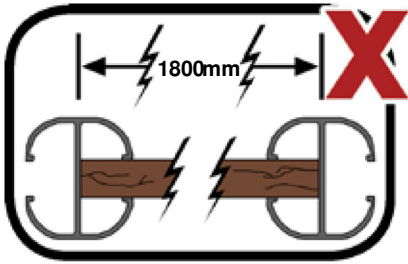

castle
COMPOSITES

BEFORE YOU START INSTALLATION

Make sure the ground is clear and prepared along the proposed fence line.



Always leave sufficient gaps at both ends of composite fence panels to allow for expansion otherwise you risk damaging the fence as a whole.

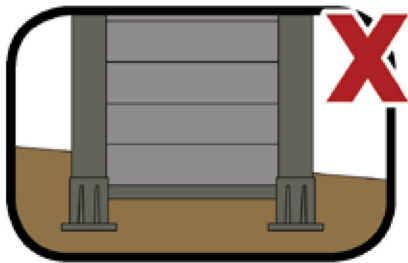
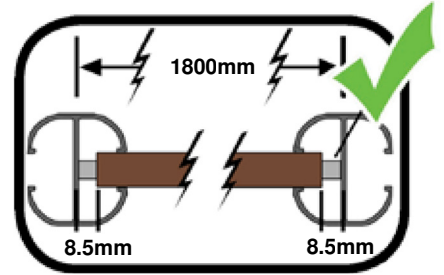

Never use Composite fencing as a gravel board or a structural product. Always bolt the bases to firm foundations. Do not bury them into the ground.

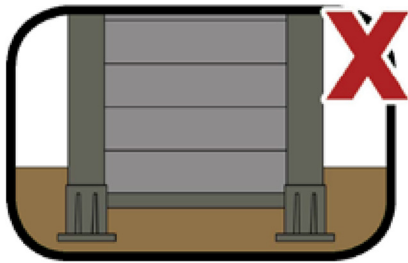
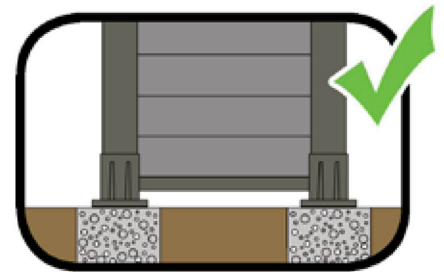

Please don't bury the bottom of the fence. A minimum gap of 30mm must be allowed for drainage at the bottom of each fence panel. Gravel can be used to hide the gap.

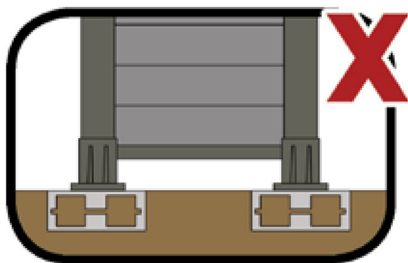
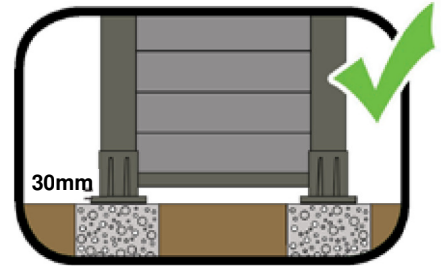

Do not fix posts to hollow bases such as breeze blocks.

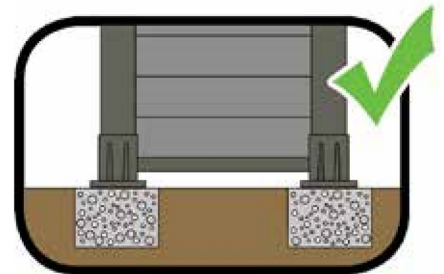

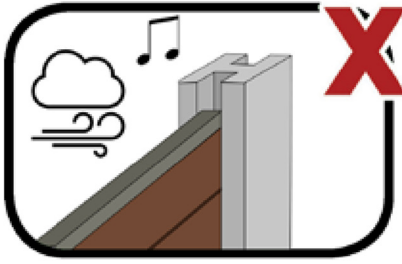

Our wall mounting post / insert must be used when installing our fencing into pre-existing concrete posts, buildings, wood posts or brick walls.

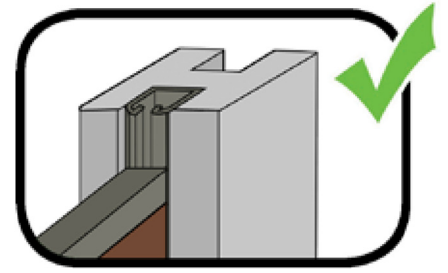



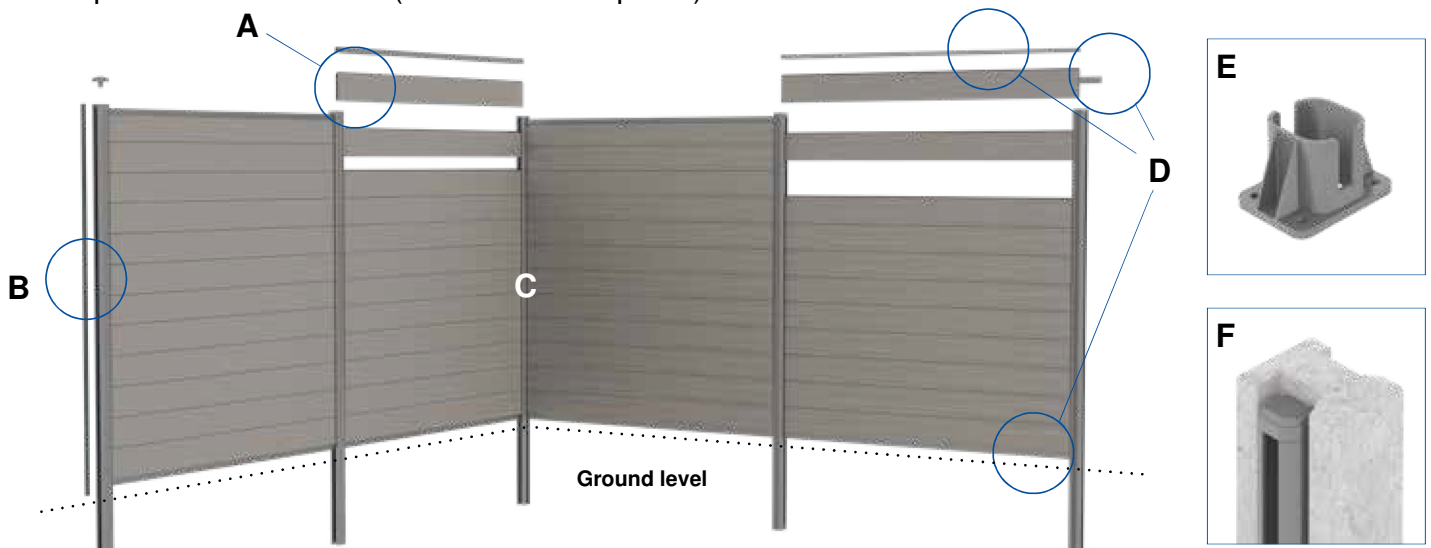

LIST OF COMPONENTS - TOOLS REQUIRED

Level, line, tape measure, mallet, screw driver, drill, M12 masonry drill bit (for bolt-down posts) and post crete / concrete (for concrete-in posts).



ID	Code	Images	Description	Size mm
A	72FPS18B		Composite Board (Includes 6 x boards per pack)	L 1783 x H 150 x D 21
B	72PC18iG		Mid / End Post for 1.8m Fence - Grey (Includes 1 x post cap with screw, 2 x plastic height setting pieces with 2 x screws, 1 x long side cover strip and 2 x short side cover strips)	H 2400 x W 73 x D 66

C	72PC18CG		Corner Post for 1.8m Fence - Grey (Includes 1 x post cap, 1 x long side cover strip and 2 x short side cover strips)	H 2400 x W 73 x D 66
D	72FPR18G		1.8m Panel Pack - Grey (Includes 1 x top rail, 1 x bottom rail and 3 x board rigidity inserts)	L 1800
E	72BFG		Base Foot - Grey (Includes 2 x screws and 4 x sleeve anchors. For use with Mid / End post only and a fence height no higher than 1.2m)	-
F	72Pi18G		Wall Mounting Post / Insert - Grey (Includes 1 x post cap and 2 x post cap screws)	H 1905 x W 48 x D 40

*Posts, base foot, panel pack and concrete post insert are Aluminium PPC RAL 7012.

There are three ways to install our composite fencing system. Please jump to the suitable figure for your individual project.

1a - Installation with aluminium base foot for panels no higher than 1.2m

1b - Installation using aluminium concrete-in posts

1c - Installation using pre-existing concrete posts or wall mounting

1a

INSTALLATION WITH ALUMINIUM BASE FOOT FOR PANELS NO HIGHER THAN 1.2m

Before you start, please be aware that there will be a 30mm gap between the ground and the bottom of the fence as it is required for drainage. The gap can be disguised with gravel to allow for water to drain away if necessary.

You are strongly advised to bolt the base foot (**72BFG**) to a flat strong concrete block with minimum dimensions of W 250 x L 250 x D 600mm. See **Figure 1**. Alternatively you can also bolt the bases to a continuous solid concrete floor base that is at least 150mm deep.

Always check that the concrete bases are level with a spirit level. We do not recommend fixing the base foot (**72BFG**) to hollow supports such as breeze blocks. Always check that the bases are facing the correct way before you bolt them down. Unless you need to cut down the boards to make up your length, please ensure that the posts are precisely 1800mm centres.

- A.** Position the first base foot (**72BFG**) with the cut out slots in line with the direction of the fence.
- B.** Mark the hole positions.
- C.** Remove the base foot (**72BFG**).
- D.** Drill $\varnothing 12\text{mm}$ holes in the solid concrete base.
- E.** Re-position the base foot (**72BFG**) and secure with the four anchor sleeves provided. See **Figure 2**.
- F.** Fix the second base foot (**72BFG**) as above ensuring post centres are 1800mm.

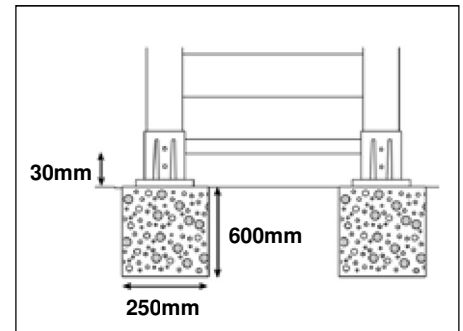

Figure 1

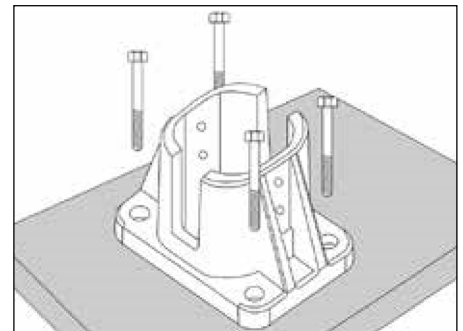

Figure 2

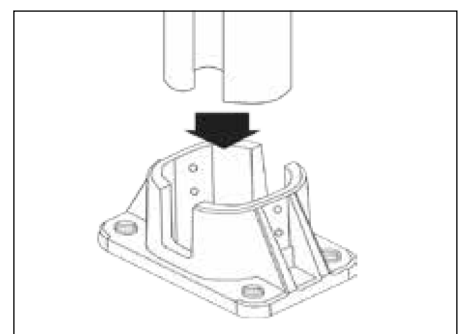
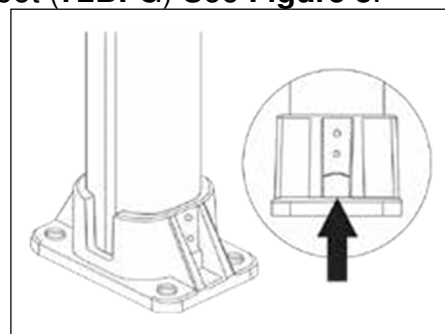

Figure 3

- G.** Cut post to required height. Push the post into the fixed base foot (**72BFG**) See **Figure 3**. Ensure they are plumb by checking with a spirit level.
- H.** Screw the two self tapping screws on each side of each post as shown. See **Figure 4**.
- I.** Slot the bottom rail (**72FPR18G**) between the two posts, pushing down until it sits on the base foot (**72BFG**).

CONTINUE TO STEP 2 (Page 6) Figure 4



1b

INSTALLATION USING ALUMINIUM CONCRETE-IN POSTS

Post installation into concrete must be done with care. We recommended using a tightened line between two stakes at the first and last posts to ensure your fence is straight. The centres of the posts must be spaced at 1800mm apart. This dimension is vital to allow the composite fence boards to expand and contract. It may be worth using the 1800mm board rigidity insert (**72FPR18G**) to position the next post. Tolerance is needed at each end of the board to allow it to expand and contract.

- A. Dig the footing holes for the posts. Holes must be a minimum of 250mm in diameter and 500mm deep into compact and solid ground. Adjust the holes dimension without reducing the height of the post above the ground, see **Figure 5**. Check and measure the height of the posts to allow for at least 1830mm height (for 1.8m fence).
- B. Pre-position the posts in the holes. The posts must be spaced at 1800mm between the post centres, see **Figure 6**. Use a board rigidity insert (**72FPR18G**) as a spacer to get the distance correct. It is necessary to leave a gap of 17mm between the fence board and the centre rib of the posts (8.5mm either side) and the board rigidity insert (**72FPR18G**) will allow for this. See **Figure 7**.
- C. Wedge the posts between the walls of the hole with stones or bricks to a height of roughly 80mm.
- D. Ensure the posts are plumb by checking with a spirit level.
- E. Fill the holes with concrete / post crete, re-check the height of the posts did not change and are still at the 1800mm post centres required. A 20kg bag will fill a hole 20cm (8") x 45cm (18"). We recommend using two people for this.
- F. Leave until concrete has fully cured before proceeding to the next step.
- G. Please be aware that a 30mm gap between the ground and the bottom of the fence will be visible as it is required for drainage. The gap can be disguised with gravel to still allow for water to drain away. Fix adjustable height risers to both bottoms of the insides of the posts, to allow for this gap. See **Figure 8**.
- H. Slot the bottom rail (**72FPR18G**) between the two posts, pushing down until it sits on both of the adjustable height risers.

CONTINUE TO STEP 2 (Page 6)

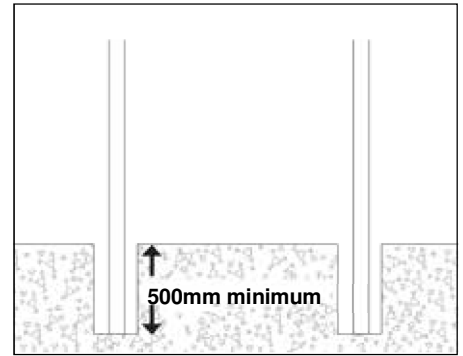

Figure 5

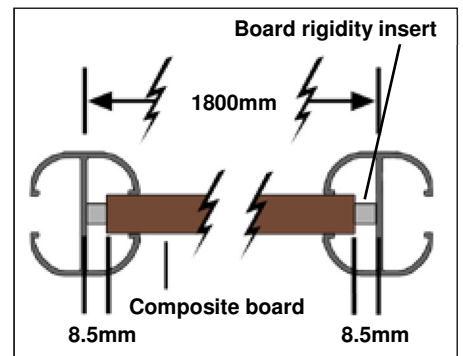

Figure 6

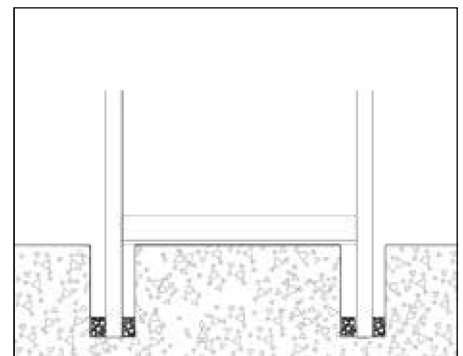

Figure 7

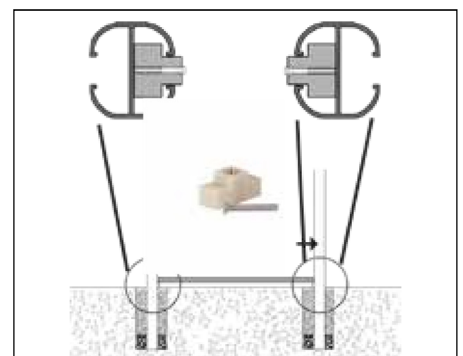
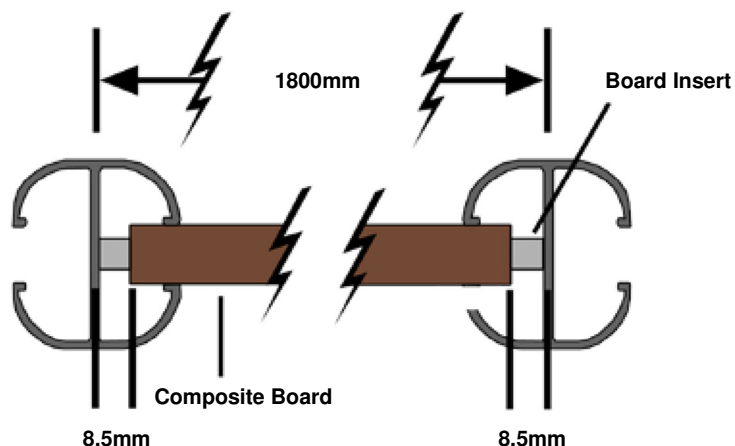

Figure 8

2 FITTING COMPOSITE BOARDS INTO ALUMINIUM POSTS

The composite board length is 1783mm (+/- 3mm) and post centres must be 1800mm. This excess is vital to allow the fence to expand and contract.

If necessary, re-cut the composite boards to allow for the required 8.5mm gaps between both ends of the board and the centres of the posts.



3 BOARD RIGIDITY INSERTS AND COMPOSITE BOARDS

Slot the board rigidity insert (72FPR18G) into the composite board (72FPS18B / C) at the following intervals:

For 1.8m tall fences, slot the insert into the 3rd, 6th and 9th fence boards before lowering the board into position. For 1.2m tall fences, slot the insert into the 2nd and 5th fence boards before lowering the boards into position.

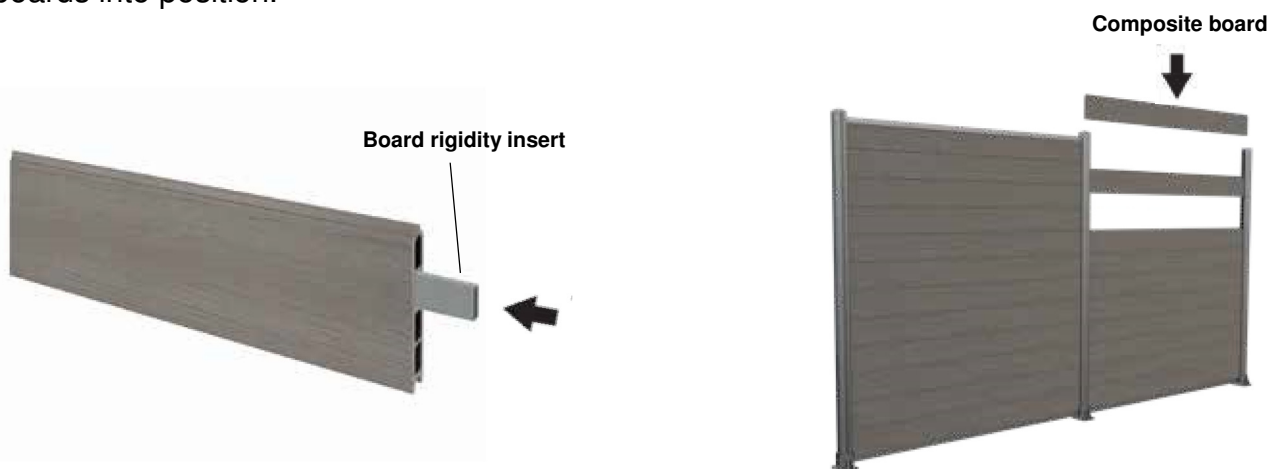

4 INSTALLATION OF ALUMINIUM TOP RAIL

For standard 6 foot wide (1800mm) panels

Push the top rail so that the grooves slot into either side of the fence post. The grooves on the top rail will secure it in place within the post.

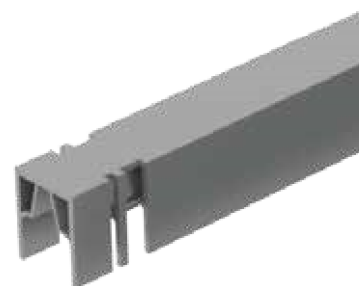

For panels cut smaller than 6 foot wide (1800mm)

Cut panels, rails and rigidity inserts to the required size. As you will have removed one of the locking end grooves secure the top rail in position with silicon sealant or adhesive.

5 INSTALLATION OF POST CAPS

FOR POSTS IN THE MIDDLE OF A RUN

- A. Push post cap onto each post. See **Figure 9**.
- B. Push the post cap bolt through the cap and post, then use the hexagonal nut to tighten. See **Figure 10**.
- C. For intermediate posts, take two short side cover strips and push into the reveals on either side of each post as shown on **Figure 11**.

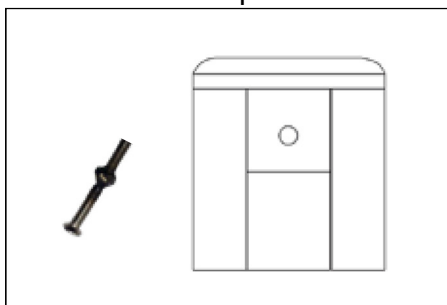

Figure 9

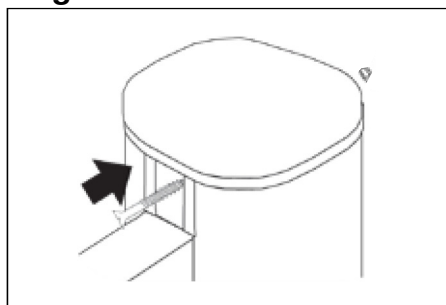

Figure 10

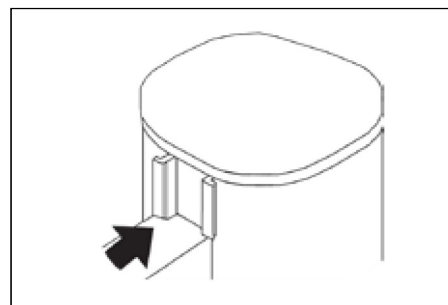

Figure 11

FOR POSTS AT THE END OF A RUN

- A. Measure the distance from the centre of the screw hole to the top of the post and pre-drill the long post end cover that has been cut to the length of the full post. Slot in place as shown. See **Figure 12**.
- B. Push the post cap in place and push the bolt through using the outer hexagonal nut to secure. See **Figure 13** & **Figure 14**.
- C. For end post, take a short side cover strip and push into the reveals on the post as shown on **Figure 15**.

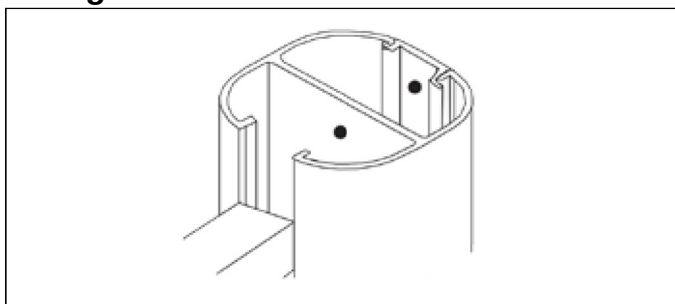

Figure 12

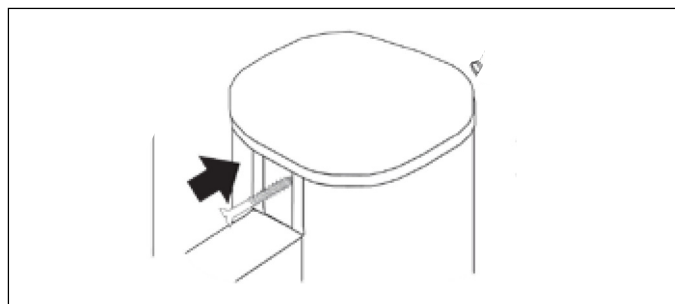

Figure 13

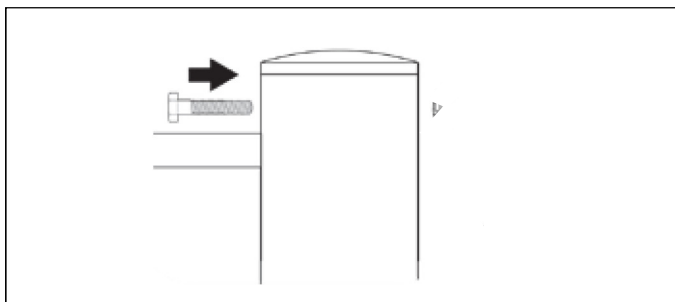

Figure 14

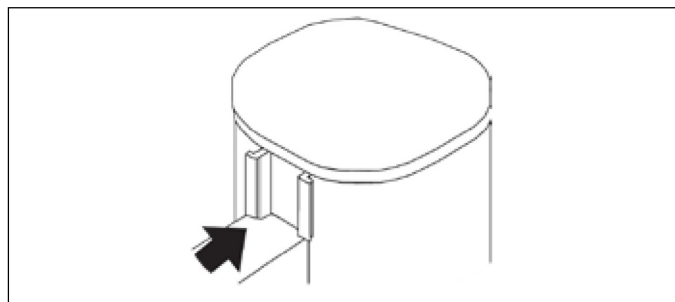

Figure 15

1c

INSTALLATION USING PRE-EXISTING CONCRETE POSTS OR WALL MOUNTING

If you are using pre-existing concrete posts, remove old fencing panels and ensure each concrete post is plumb, and at a maximum of 1800mm centres. If the gap distance between the posts are smaller than the composite board (**72FPS18B / C**) and panel pack (**72FPR18G**), they can be cut to size to fit.

Pre-existing concrete post installation



- A. Insert concrete gravel boards into each proposed panel.
- B. Measure lengths of wall mounting post / insert (**7Pi18G**) to

suit the reveals on each side of all concrete posts to be used. Cut to length if necessary.

- C.** Slot each wall mounting post / insert (**7Pi18G**) into place and fix with either screws / plugs or glue depending on your posts and preference. **Please note:** Concrete posts are reinforced with rebar and the position of these bars could vary.



- D.** The composite board (**72FPS18B / C**) length is 1783mm (+/- 3mm) and a 1800mm gap must be allowed for between posts. This excess is vital to allow the fence to expand and contract.

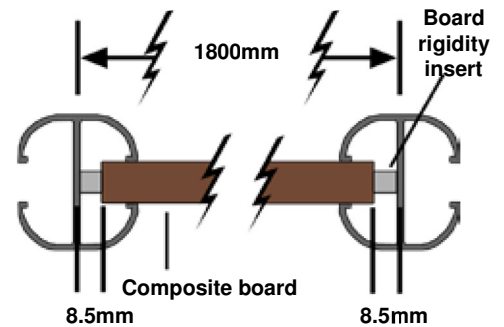

- E.** If necessary, re-cut the boards to allow for the required 8.5mm gap between the end of the board and the centre of the posts.

- F.** Slot the board rigidity insert (**72FPR18G**) into the composite board (**72FPS18B / C**) before lowering into position at the following intervals:



For 1.8m tall fences slot the insert into the 3rd, 6th and 9th fence boards width. For 1.2m tall fences slot the insert into the 2nd and 5th fence boards width.

H.

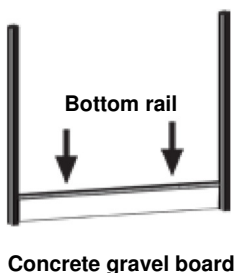

I.

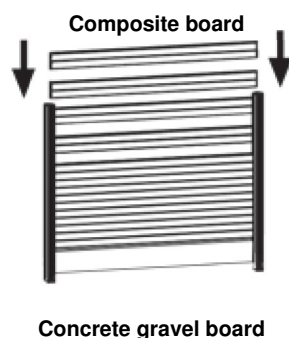

2c INSTALLATION OF POST CAP

Do not stick, solder or screw boards to each other or the posts.

- Push post caps onto each top of each wall mounting post / insert (**7Pi18G**) to finish.
- Pre-drill the post on both sides so there is a hole through both prongs centres.
- Screw in place using the screws provided.



MAINTENANCE OF COMPOSITE BOARDS

Boards require little maintenance. We recommend you to wash your boards as necessary with soap and water. For a standard washing, use soft detergent and water.

If mould / mildew appears on your boards, clean with a product containing chlorine bleach. Test on a hidden area first. For oil and grease stain, wash immediately with a degreasing agent.

If necessary use a medium grain sand paper and sand slightly in the direction of the grain. Rinse the board before doing this operation. Brushing and sanding may generate a slight discolouration of the board, which is absolutely normal, and will vanish over time.

Do not use solvent based material. Do not stain, oil or use normal paint on our fence boards.

Caution: In protected or semi protected areas (trees, vegetation...) dampness stains may appear. Stains vanish under UV. If necessary rinse evenly with water and let dry naturally.

MAINTENANCE OF ALUMINIUM COMPONENTS

These parts do not require any specific maintenance. We do not recommend the use of any acid based product, and do not advise the use of solvent which can affect the painting. These components are an aluminium alloy; consequently they do not rust. You can maintain them with standard cleaning materials.

STORAGE AND HANDLING

All fence components should be stored indoors away from UV, rain and damp and be kept in their packaging until installation. Fence boards should be stored on a flat and ventilated surface and correctly supported on beams at 300mm centres.

REMINDERS

The colour of the boards will slightly change during the first weeks following the installation. If ordering an additional board, you may observe a slight difference with the ones installed, which is again absolutely normal as the difference will vanish over the time due to UV exposure. Colours may slightly differ to samples received due to goods being ordered in different batches to samples as all fence panels are made from recycled product. Due to this we recommend ordering all goods in one batch.

Composite boards are guaranteed for 10 years against rot and insects in normal conditions of use. This guarantee covers replacement of damaged products only. Installation and related costs are excluded from the guarantee.

As our composite is a man-made recycled product, colour variations are to be expected. Our warranty does not cover colour fade, discolouration, water marks, or stains on our products.

To make sure you get the full advantage from your new composite fencing, we recommend our customers use a qualified, professional installer to fit our system. Please contact our team if you have any queries or questions in regards the installation process prior to commencing the job.

