



RADIO TEST REPORT

ETSI EN 300 086 V2.1.2

For

Applicant: Fujian Baofeng Electronics Co., Ltd.

Address: Changfu Industrial Zone, Xiamei, Nan'an, Quanzhou, Fujian, China

Product Name: UHF FM TRANSCEIVER

Model Name: BF-888S, BF-666S, BF-777S, GT-1, BF-888SA, BF-888Splus

Remark: Only difference in model names

Trade Name: BAOFENG

Report No.: MTE/AVJ/E18071301

Date of Issue: Jul. 12 2018

Issued by: Shenzhen Most Technology Service Co., Ltd.

Address : No.5, 2nd Langshan Road, North District, Hi-tech Industrial Park,
Nanshan, Shenzhen, Guangdong, China

Tel : 86-740-8602 6850

Fax : 86-740-2601 3350



The report consists 40 pages in total. It may be duplicated completely for legal use with the approval of the applicant. It should not be reproduced except in full, without the written approval of our laboratory. The client should not use it to claim product endorsement by MOST. The test results in the report only apply to the tested sample. The test report shall be invalid without all the signatures of testing engineers, reviewer and approver.

TABLE OF CONTENTS

1. TEST RESULT CERTIFICATION	3
2. EUT DESCRIPTION	4
3. TEST METHODOLOGY	5
3.1. GENERAL DESCRIPTION OF APPLIED STANDARDS	5
3.2. DESCRIPTION OF TEST MODES	5
4. TEST RESULTS	6
5. FACILITIES AND ACCREDITATIONS	7
5.1. IDENTIFICATION OF THE RESPONSIBLE TESTING LABORATORY	7
5.2. IDENTIFICATION OF THE RESPONSIBLE TESTING LOCATION	7
5.3. LIST OF TEST EQUIPMENTS	7
6. SETUP OF EQUIPMENT UNDER TEST	8
6.1. SETUP CONFIGURATION OF EUT	8
6.2. SUPPORT EQUIPMENT.....	8
7. ETSI EN 300 086 REQUIREMENTS	9
7.1. FREQUENCY ERROR.....	9
7.2. TRANSMITTER POWER (CONDUCTED).....	18
7.3. TRANSMITTER FREQUENCY DEVIATION	27
7.4. ADJACENT AND ALTERNATE CHANNEL POWER	32
7.5. TRANSMITTER UNWANTED EMISSIONS IN THE SPURIOUS	41
7.6. RECEIVER MAXIMUM USEABLE SENSITIVITY	45
7.7. RECEIVER CO-CHANNEL REJECTION	46
7.8. RECEIVER ADJACENT CHANNEL SELECTIVITY	47
7.9. RECEIVER SPURIOUS RESPONSE REJECTION	48
7.10. RECEIVER INTER-MODULATION RESPONSE REJECTION	49
7.11. RECEIVER BLOCKING OR DESENSITIZATION	50
7.12. RECEIVER SPURIOUS RADIATIONS	51

1. TEST RESULT CERTIFICATION

Product Name:	UHF FM TRANSCEIVER
Trade Name:	BAOFENG
Model Name:	BF-888S
Series Model Name:	BF-666S, BF-777S, GT-1, BF-888SA, BF-888Splus
Difference description:	Only difference in model names
Applicant:	Fujian Baofeng Electronics Co., Ltd.
Applicant Address:	Changfu Industrial Zone, Xiamei, Nan'an, Quanzhou, Fujian, China
Manufacturer:	Fujian Baofeng Electronics Co., Ltd.
Manufacturer Address:	Changfu Industrial Zone, Xiamei, Nan'an, Quanzhou, Fujian, China
Test Standards:	ETSI EN 300 086 V2.1.2 (2016-08)
Test Date:	Jul.02-Jul.11, 2018
Test Result:	PASS

The above equipment was tested by MOST for compliance with the requirements set forth in the European Standard ETSI EN 300 086 v2.1.2. The results of testing in this report apply to the product /system which were tested only. Other similar equipment will not necessarily produce the same results due to production tolerance and measurement uncertainties.

Prepared by (+ signature):

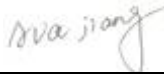

Ava jiang

Jul.02-Jul.11, 2018

Review by (+ signature):

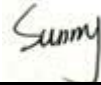

Sunny Deng

Jul.12, 2018

Approved by (+ signature):



Yvette Zhou (Manager)

Jul.12, 2018

2. EUT DESCRIPTION

Product Name:	UHF FM TRANSCEIVER
Brand Name:	BAOFENG
Model Number:	BF-888S
Power Supply:	1、 110-240AC, 50Hz, 0.25A Max Output:5V DC, 0.5A 2、 DC 3.7V by battery
Frequency Range:	400~470MHz
Measurement Frequency:	1:400.05MHz, 2:417.00MHz, 3:435.00MHz, 4:452.00MHz, 5:469.95MHz
Output Power:	5W/1W
Channel Separation:	12.5 kHz / 25kHz
Modulation Technique:	F3E
Temperature Range:	0°C ~ +40°C
Software Version:	666-NEWMCU-V16 2016-12-17
Hardware Version:	666-NEWMCU-V16 2016-12-17

channels list		
400.0125MHz	Increase by 12.5KHz	469.9500 MHz
400.0250 MHz		469.9625 MHz
400.0375 MHz		469.9750 MHz
400.0500 MHz		469.9875 MHz

NOTE:

1. For a more detailed features description about the EUT, please refer to User's Manual.

3. TEST METHODOLOGY

3.1. GENERAL DESCRIPTION OF APPLIED STANDARDS

Perform Radio Spectrum tests for CE Marking according to the provisions of article 3.2 of the RED Directive (2014/53/EC) for the EUT has been tested according to ETSI EN 300 086 V2.1.2.(2016-08).

ETSI EN 300086 V2.1.2(2016-08)	Electromagnetic compatibility and Radio spectrum Matters(ERM);Land Mobile Service; Radio equipment with an internal or external RF connector intended primarily for analogue speech; Technical characteristics and methods of measurement and Harmonized EN covering essential requirements under article3.2 of the RED Directive
-----------------------------------	---

3.2. DESCRIPTION OF TEST MODES

The EUT has been tested under typical operating condition. No software used to control the EUT for staying in transmitting and receiving mode for testing.

4. TEST RESULTS

Test items and the results are as bellow:

Technical characteristics of the transmitter			
No	Section	Test Item	Result
1	EN 300 086 Sub-clause 7.1	Transmitter frequency error	PASS
2	EN 300 086 Sub-clause 7.2	Transmitter power (conducted)	PASS
3	EN 300 086 Sub-clause 7.3	Transmitter maximum effective radiated power	N/A note 1
4	EN 300 086 Sub-clause 7.4	Transmitter frequency deviation	PASS
5	EN 300 086 Sub-clause 7.5	Transmitter adjacent and alternate channel power	PASS
6	EN 300 086 Sub-clause 7.6	Transmitter unwanted emissions in the spurious domain	PASS
7	EN 300 086 Sub-clause 7.7	Transmitter intermodulation attenuation	N/A note 2
Technical characteristics of the receiver			
No	Section	Test Item	Result
1	EN 300 086 Sub-clause 8.1	Receiver maximum useable sensitivity	PASS
2	EN 300 086 Sub-clause 8.2	Receiver maximum useable sensitivity (field strength)	N/A
3	EN 300 086 Sub-clause 8.3	Receiver co-channel rejection	PASS
4	EN 300 086 Sub-clause 8.4	Receiver adjacent channel selectivity	PASS
5	EN 300 086 Sub-clause 8.5	Receiver spurious response rejection	PASS
6	EN 300 086 Sub-clause 8.6	Receiver inter-modulation response rejection	PASS
7	EN 300 086 Sub-clause 8.7	Receiver blocking or desensitization	PASS
8	EN 300 086 Sub-clause 8.8	Receiver spurious radiations	PASS
9	EN 300 086 Sub-clause 9.1	Receiver desensitization (with simultaneous transmission and reception)	N/A note 3
10	EN 300 086 Sub-clause 9.2	Receiver spurious response rejection (with simultaneous transmission and reception)	N/A note 3

NOTE:

1. EUT is with the external port device;
2. Applies only to transmitters to be used in base stations
3. Applies only to equipment using duplex equipment.

5. FACILITIES AND ACCREDITATIONS

5.1. IDENTIFICATION OF THE RESPONSIBLE TESTING LABORATORY

Company Name:	Shenzhen Most Technology Service Co., Ltd.
Address:	No.5, Langshan 2nd Rd., North Hi-Tech Industrial park ,Nanshan, Shenzhen, Guangdong ,China

5.2. IDENTIFICATION OF THE RESPONSIBLE TESTING LOCATION

Test Site:	Shenzhen Most Technology Service Co., Ltd.
Address:	No.5, Langshan 2nd Rd., North Hi-Tech Industrial park ,Nanshan, Shenzhen, Guangdong ,China
Description:	There is one 3m semi-anechoic an area test sites and two line conducted labs for final test. The Open Area Test Sites and the Line Conducted labs are constructed and calibrated to meet the FCC requirements in documents ANSI C63.4 and CISPR 16 requirements. The CNAS Registration Number is CNAS L3573 .

5.3. LIST OF TEST EQUIPMENTS

No.	Equipment	Manufacturer	Model No.	S/N	Calibration Date	Cal. Interval
1	Test Receiver	Rohde & Schwarz	ESCI	100492	2018/03/10	1 Year
2	Spectrum Analyzer	Agilent	E7405A	US44210471	2018/03/10	1 Year
3	RF Cable	SchwarzBeck	N/A	No.1	2018/03/10	1 Year
4	Bilog Antenna	Sunol	JB3	A121206	2018/03/10	1 Year
5	Horn Antenna	SCHWARZBECK	BBHA9120D	756	2018/03/10	1 Year
6	Cable	Resenberger	N/A	NO.1	2018/03/10	1 Year
7	DC Power Filter	DuoJi	DL2×30B	N/A	2018/03/10	1 Year
8	Single Phase Power Line Filter	DuoJi	FNF 202B30	N/A	2018/03/10	1 Year
9	3 Phase Power Line Filter	DuoJi	FNF 402B30	N/A	2018/03/10	1 Year
10	Telecommunication Antenna	European Antennas	PSA 75301R/170	0304213	2018/03/10	1 Year
11	Telecommunication Test Equipment	R&S	CMU200	N/A	2018/03/10	1 Year

NOTE: Equipments listed above have been calibrated and are in the period of validation.

6. SETUP OF EQUIPMENT UNDER TEST

6.1. SETUP CONFIGURATION OF EUT

See test photographs attached in Appendix 1 for the actual connections between EUT and support equipment.

6.2. SUPPORT EQUIPMENT

No.	Device Type	Brand	Model	Series No.	Data Cable	Power Cord
1	--	--	--	--	--	--

Notes:

1. All the equipment/cables were placed in the worst-case configuration to maximize the emission during the test.
2. Grounding was established in accordance with the manufacturer's requirements and conditions for the intended use.

7. ETSI EN 300 086 REQUIREMENTS

7.1. FREQUENCY ERROR

TEST LIMIT

ETSI EN 300 086 (V.2.1.2) Sub-clause 7.1.3

The frequency error, as defined in EN 300 086 sub-clause 7.1.1, shall not exceed the limits in EN 300 086 sub-clause 7.1.3 table 2 under normal, extreme or any intermediate set of conditions.

Table 2

Channel separation (kHz)	Frequency error limit (kHz)				
	below 47 MHz	47 MHz to 137 MHz	above 137 MHz to 300 MHz	above 300 MHz to 500 MHz	above 500 MHz to 1 000 MHz
20 and 25	±0,60	±1,35	±2,00	±2,00	±2,50 (a)
12,5	+0,60	+1,00	+1,00 (B) ±1,50 (M)	+1,00 (B) ±1,50 (a) (M)	+1,5 (B) ±2,5 (a) (M)

NOTE: (B) = base station.
(M) = mobile or hand portable station.
(a) = for hand portable stations having integral power supplies, the frequency error shall not be exceeded over a temperature range of 0 °C to + 40 °C.
Under extreme temperature conditions (clause 5.4.1), the frequency error shall not exceed ±2,50 kHz for a channel separation of 12,5 kHz between 300 MHz and 500 MHz, and ±3,00 kHz for channel separations of 20 kHz and 25 kHz between 500 MHz and 1 000 MHz.

TEST CONFIGURATION

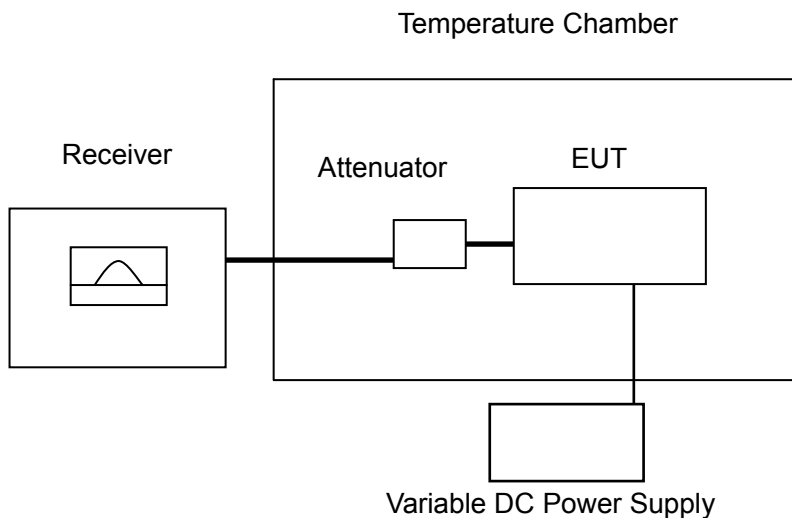

TEST PROCEDURE

1. Please refer to ETSI EN 300 086 (V2.1.2) Sub-clause 5.3 and Sub-clause 5.4 for the test conditions.
2. Please refer to ETSI EN 300 086 (V2.1.2) Sub-clause 7.1.2 for the measurement method

TEST RESULTS

High power

400.05MHZ of 25 KHz Channel Separation

Test Condition		Frequency Measured (MHz)	Frequency Error (KHz)
Temperature (°C)	Voltage (V)		
T _{nor} (+25)	DC 3.7	400.05030	0.30
T _{min} (0)	DC 3.15	400.05034	0.34
	DC 3.7	400.05029	0.29
T _{max} (+40)	DC 3.15	400.05040	0.40
	DC 3.7	400.05021	0.21
Limit		Normal=±2.00 KHz, Extreme=±3.00 KHz @ 400.05MHz	
Result		Pass	

417.00MHZ of 25 KHz Channel Separation

Test Condition		Frequency Measured (MHz)	Frequency Error (KHz)
Temperature (°C)	Voltage (V)		
T _{nor} (+25)	DC 3.7	417.00033	0.33
T _{min} (0)	DC 3.15	417.00034	0.34
	DC 3.7	417.00033	0.33
T _{max} (+40)	DC 3.15	417.00020	0.20
	DC 3.7	417.00023	0.23
Limit		Normal=±2.00 KHz, Extreme=±3.00 KHz @ 417.00MHz	
Result		Pass	

435.00MHZ of 25 KHz Channel Separation

Test Condition		Frequency Measured (MHz)	Frequency Error (KHz)
Temperature (°C)	Voltage (V)		
T _{nor} (+25)	DC 3.7	435.00021	0.21
T _{min} (0)	DC 3.15	435.00036	0.36
	DC 3.7	435.00035	0.35
T _{max} (+40)	DC 3.15	435.00037	0.37
	DC 3.7	435.00024	0.24
Limit		Normal=±2.00 KHz, Extreme=±3.00 KHz @ 435.00MHz	
Result		Pass	

452.00MHZ of 25 KHz Channel Separation

Test Condition		Frequency Measured (MHz)	Frequency Error (KHz)
Temperature (°C)	Voltage (V)		
T _{nor} (+25)	DC 3.7	452.00037	0.37
T _{min} (0)	DC 3.15	452.00045	0.45
	DC 3.7	452.00030	0.30
T _{max} (+40)	DC 3.15	452.00042	0.42
	DC 3.7	452.00024	0.24
Limit		Normal=±2.00 KHz, Extreme=±3.00 KHz @ 452.00MHz	
Result		Pass	

469.95MHZ of 25 KHz Channel Separation

Test Condition		Frequency Measured (MHz)	Frequency Error (KHz)
Temperature (°C)	Voltage (V)		
T _{nor} (+25)	DC 3.7	469.95034	0.34
T _{min} (0)	DC 3.15	469.95040	0.40
	DC 3.7	469.95043	0.43
T _{max} (+40)	DC 3.15	469.95026	0.26
	DC 3.7	469.95025	0.25
Limit		Normal=±2.00 KHz, Extreme=±3.00 KHz @ 469.95 MHz	
Result		Pass	

Low power**400.05MHZ of 25 KHz Channel Separation**

Test Condition		Frequency Measured (MHz)	Frequency Error (KHz)
Temperature (°C)	Voltage (V)		
T _{nor} (+25)	DC 3.7	400.05040	0.40
T _{min} (0)	DC 3.15	400.05032	0.32
	DC 3.7	400.05040	0.40
T _{max} (+40)	DC 3.15	400.05043	0.43
	DC 3.7	400.05041	0.41
Limit		Normal=±2.00 KHz, Extreme=±3.00 KHz @ 400.05MHz	
Result		Pass	

417.00MHZ of 25 KHz Channel Separation

Test Condition		Frequency Measured (MHz)	Frequency Error (KHz)
Temperature (°C)	Voltage (V)		
T _{nor} (+25)	DC 3.7	417.00036	0.36
T _{min} (0)	DC 3.15	417.00031	0.31
	DC 3.7	417.00041	0.41
T _{max} (+40)	DC 3.15	417.00038	0.38
	DC 3.7	417.00025	0.25
Limit		Normal=±2.00 KHz, Extreme=±3.00 KHz @ 417.00MHz	
Result		Pass	

435.00MHZ of 25 KHz Channel Separation

Test Condition		Frequency Measured (MHz)	Frequency Error (KHz)
Temperature (°C)	Voltage (V)		
T _{nor} (+25)	DC 3.7	435.00020	0.20
T _{min} (0)	DC 3.15	435.00046	0.46
	DC 3.7	435.00044	0.44
T _{max} (+40)	DC 3.15	435.00030	0.30
	DC 3.7	435.00043	0.43
Limit		Normal=±2.00 KHz, Extreme=±3.00 KHz @ 435.00MHz	
Result		Pass	

452.00MHZ of 25 KHz Channel Separation

Test Condition		Frequency Measured (MHz)	Frequency Error (KHz)
Temperature (°C)	Voltage (V)		
T _{nor} (+25)	DC 3.7	452.00024	0.24
T _{min} (0)	DC 3.15	452.00038	0.38
	DC 3.7	452.00029	0.29
T _{max} (+40)	DC 3.15	452.00040	0.40
	DC 3.7	452.00038	0.38
Limit		Normal=±2.00 KHz, Extreme=±3.00 KHz @ 452.00MHz	
Result		Pass	

469.95MHZ of 25 KHz Channel Separation

Test Condition		Frequency Measured (MHz)	Frequency Error (KHz)
Temperature (°C)	Voltage (V)		
T _{nor} (+25)	DC 3.7	469.95036	0.36
T _{min} (0)	DC 3.15	469.95038	0.38
	DC 3.7	469.95040	0.40
T _{max} (+40)	DC 3.15	469.95021	0.21
	DC 3.7	469.95031	0.31
Limit		Normal=±2.00 KHz, Extreme=±3.00 KHz @ 469.95 MHz	
Result		Pass	

High power**400.05MHZ of 12.5KHz Channel Separation**

Test Condition		Frequency Measured (MHz)	Frequency Error (KHz)
Temperature (°C)	Voltage (V)		
T _{nor} (+25)	DC 3.7	400.05028	0.28
T _{min} (0)	DC 3.15	400.05031	0.31
	DC 3.7	400.05042	0.42
T _{max} (+40)	DC 3.15	400.05038	0.38
	DC 3.7	400.05034	0.34
Limit		Normal=±1.5KHz, Extreme=±2.50KHz@400.05MHz	
Result		Pass	

417.00MHZ of 12.5KHz Channel Separation

Test Condition		Frequency Measured (MHz)	Frequency Error (KHz)
Temperature (°C)	Voltage (V)		
T _{nor} (+25)	DC 3.7	417.00038	0.38
T _{min} (0)	DC 3.15	417.00045	0.45
	DC 3.7	417.00038	0.38
T _{max} (+40)	DC 3.15	417.00044	0.44
	DC 3.7	417.00037	0.37
Limit		Normal=±1.5KHz, Extreme=±2.50KHz@417.00MHz	
Result		Pass	

435.00MHZ of 12.5KHz Channel Separation

Test Condition		Frequency Measured (MHz)	Frequency Error (KHz)
Temperature (°C)	Voltage (V)		
T _{nor} (+25)	DC 3.7	435.00026	0.26
T _{min} (0)	DC 3.15	435.00039	0.39
	DC 3.7	435.00047	0.47
T _{max} (+40)	DC 3.15	435.00048	0.48
	DC 3.7	435.00031	0.31
Limit		Normal=±1.5KHz, Extreme=±2.50KHz@435.00MHz	
Result		Pass	

452.00MHZ of 12.5KHz Channel Separation

Test Condition		Frequency Measured (MHz)	Frequency Error (KHz)
Temperature (°C)	Voltage (V)		
T _{nor} (+25)	DC 3.7	452.00034	0.34
T _{min} (0)	DC 3.15	452.00047	0.47
	DC 3.7	452.00042	0.42
T _{max} (+40)	DC 3.15	452.00026	0.26
	DC 3.7	452.00042	0.42
Limit		Normal=±1.5KHz, Extreme=±2.50KHz@452.00MHz	
Result		Pass	

469.95MHZ of 12.5KHz Channel Separation

Test Condition		Frequency Measured (MHz)	Frequency Error (KHz)
Temperature (°C)	Voltage (V)		
T _{nor} (+25)	DC 3.7	469.95030	0.30
T _{min} (0)	DC 3.15	469.95047	0.47
	DC 3.7	469.95040	0.40
T _{max} (+40)	DC 3.15	469.95028	0.28
	DC 3.7	469.95044	0.44
Limit		Normal=±1.5KHz, Extreme=±2.50KHz@469.95 MHz	
Result		Pass	

Low power**400.05MHZ of 12.5KHz Channel Separation**

Test Condition		Frequency Measured (MHz)	Frequency Error (KHz)
Temperature (°C)	Voltage (V)		
T _{nor} (+25)	DC 3.7	400.05035	0.35
T _{min} (0)	DC 3.15	400.05037	0.37
	DC 3.7	400.05034	0.34
T _{max} (+40)	DC 3.15	400.05048	0.48
	DC 3.7	400.05047	0.47
Limit		Normal=±1.5KHz, Extreme=±2.50KHz@400.05MHz	
Result		Pass	

417.00MHZ of 12.5KHz Channel Separation

Test Condition		Frequency Measured (MHz)	Frequency Error (KHz)
Temperature (°C)	Voltage (V)		
T _{nor} (+25)	DC 3.7	417.00024	0.24
T _{min} (0)	DC 3.15	417.00037	0.37
	DC 3.7	417.00045	0.45
T _{max} (+40)	DC 3.15	417.00021	0.21
	DC 3.7	417.00022	0.22
Limit		Normal=±1.5KHz, Extreme=±2.50KHz@417.00MHz	
Result		Pass	

435.00MHZ of 12.5KHz Channel Separation

Test Condition		Frequency Measured (MHz)	Frequency Error (KHz)
Temperature (°C)	Voltage (V)		
T _{nor} (+25)	DC 3.7	435.00020	0.20
T _{min} (0)	DC 3.15	435.00048	0.48
	DC 3.7	435.00028	0.28
T _{max} (+40)	DC 3.15	435.00036	0.36
	DC 3.7	435.00037	0.37
Limit		Normal=±1.5KHz, Extreme=±2.50KHz@435.00MHz	
Result		Pass	

452.00MHZ of 12.5KHz Channel Separation

Test Condition		Frequency Measured (MHz)	Frequency Error (KHz)
Temperature (°C)	Voltage (V)		
T _{nor} (+25)	DC 3.7	452.00035	0.35
T _{min} (0)	DC 3.15	452.00043	0.43
	DC 3.7	452.00042	0.42
T _{max} (+40)	DC 3.15	452.00032	0.32
	DC 3.7	452.00048	0.48
Limit		Normal=±1.5KHz, Extreme=±2.50KHz@452.00MHz	
Result		Pass	

469.95MHZ of 12.5KHz Channel Separation

Test Condition		Frequency Measured (MHz)	Frequency Error (KHz)
Temperature (°C)	Voltage (V)		
T _{nor} (+25)	DC 3.7	469.95032	0.32
T _{min} (0)	DC 3.15	469.95035	0.35
	DC 3.7	469.95033	0.33
T _{max} (+40)	DC 3.15	469.95024	0.24
	DC 3.7	469.95049	0.49
Limit		Normal=±1.5KHz, Extreme=±2.50KHz@469.95 MHz	
Result		Pass	

Note:

1. The Measurement uncertainty value is $\pm 1 \times 10^{-7}$.

7.2. TRANSMITTER POWER (CONDUCTED)

TEST LIMIT

ETSI EN 300 086 (V2.1.2) Sub-clause 7.2.3

For the definition and the measuring method see clause 7.2.2. The transmitter output power (conducted) under normal test conditions shall be within ± 1.50 dB of the rated output power. The transmitter power (conducted) under extreme test conditions shall be within +2.0 dB and -3.0 dB of the rated output power.

TEST CONFIGURATION

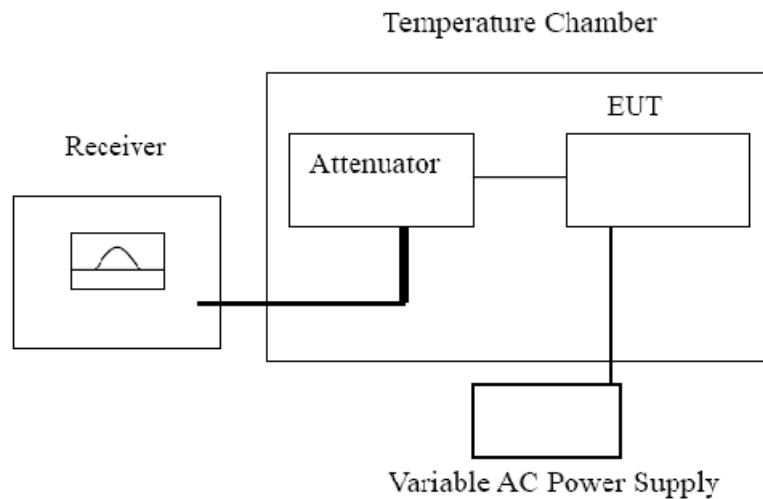

TEST PROCEDURE

1. Please refer to ETSI EN 300 086 (V2.1.2) Sub-clause 5.3 and 5.4 for the test conditions.
2. Please refer to ETSI EN 300 086 (V2.1.2) Sub-clause 7.2.2 for the measurement method.

TEST RESULTS

High power

400.05MHz of 12.5 KHz Channel Separation

Test Condition		Conducted Power (dBm)	Power Error (dB)
Temperature (°C)	Voltage (V)		
T _{nor} (+25)	DC 3.7	36.75	-0.25
T _{min} (0)	DC 3.15	36.60	-0.40
	DC 3.7	36.74	-0.26
T _{max} (+40)	DC 3.15	36.71	-0.29
	DC 3.7	36.78	-0.22
Nominal Power= 36.99dBm; Limit n=±1.5 dB and Limit e=+2.0 dB & -3.0 dB			
Result		Pass	

417.00MHZ of 12.5 KHz Channel Separation

Test Condition		Conducted Power (dBm)	Power Error (dB)
Temperature (°C)	Voltage (V)		
T _{nor} (+25)	DC 3.7	36.65	-0.35
T _{min} (0)	DC 3.15	36.67	-0.33
	DC 3.7	36.73	-0.27
T _{max} (+40)	DC 3.15	36.65	-0.35
	DC 3.7	36.52	-0.48
Nominal Power= 36.99dBm; Limit n=±1.5 dB and Limit e=+2.0 dB & -3.0 dB			
Result		Pass	

435.00MHZ of 12.5 KHz Channel Separation

Test Condition		Conducted Power (dBm)	Power Error (dB)
Temperature (°C)	Voltage (V)		
T _{nor} (+25)	DC 3.7	36.77	-0.23
T _{min} (0)	DC 3.15	36.62	-0.38
	DC 3.7	36.66	-0.34
T _{max} (+40)	DC 3.15	36.71	-0.29
	DC 3.7	36.73	-0.27
Nominal Power= 36.99dBm; Limit n=±1.5 dB and Limit e=+2.0 dB & -3.0 dB			
Result		Pass	

452.00MHZ of 12.5 KHz Channel Separation

Test Condition		Conducted Power (dBm)	Power Error (dB)
Temperature (°C)	Voltage (V)		
T _{nor} (+25)	DC 3.7	36.74	-0.26
T _{min} (0)	DC 3.15	36.53	-0.47
	DC 3.7	36.57	-0.43
T _{max} (+40)	DC 3.15	36.62	-0.38
	DC 3.7	36.77	-0.23
Nominal Power= 36.99dBm; Limit n=±1.5 dB and Limit e=+2.0 dB & -3.0 dB			
Result		Pass	

469.95MHZ of 12.5 KHz Channel Separation

Test Condition		Conducted Power (dBm)	Power Error (dB)
Temperature (°C)	Voltage (V)		
T _{nor} (+25)	DC 3.7	36.65	-0.35
T _{min} (0)	DC 3.15	36.67	-0.33
	DC 3.7	36.53	-0.47
T _{max} (+40)	DC 3.15	36.51	-0.49
	DC 3.7	36.79	-0.21
Nominal Power= 36.99dBm; Limit n=±1.5 dB and Limit e=+2.0 dB & -3.0 dB			
Result		Pass	

Low power

400.05MHZ of 12.5 KHz Channel Separation

Test Condition		Conducted Power (dBm)	Power Error (dB)
Temperature (°C)	Voltage (V)		
T _{nor} (+25)	DC 3.7	29.80	-0.20
T _{min} (0)	DC 3.15	29.54	-0.46
	DC 3.7	29.61	-0.39
T _{max} (+40)	DC 3.15	29.76	-0.24
	DC 3.7	29.76	-0.24
Nominal Power= 30dBm; Limit n=±1.5 dB and Limit e=+2.0 dB & -3.0 dB			
Result		Pass	

417.00MHZ of 12.5 KHz Channel Separation

Test Condition		Conducted Power (dBm)	Power Error (dB)
Temperature (°C)	Voltage (V)		
T _{nor} (+25)	DC 3.7	29.69	-0.31
T _{min} (0)	DC 3.15	29.64	-0.36
	DC 3.7	29.67	-0.33
T _{max} (+40)	DC 3.15	29.64	-0.36
	DC 3.7	29.67	-0.33
Nominal Power= 30dBm; Limit n=±1.5 dB and Limit e=+2.0 dB & -3.0 dB			
Result		Pass	

435.00MHZ of 12.5 KHz Channel Separation

Test Condition		Conducted Power (dBm)	Power Error (dB)
Temperature (°C)	Voltage (V)		
T _{nor} (+25)	DC 3.7	29.68	-0.32
T _{min} (0)	DC 3.15	29.66	-0.34
	DC 3.7	29.60	-0.40
T _{max} (+40)	DC 3.15	29.62	-0.38
	DC 3.7	29.61	-0.39
Nominal Power= 30dBm; Limit n=±1.5 dB and Limit e=+2.0 dB & -3.0 dB			
Result		Pass	

452.00MHZ of 12.5 KHz Channel Separation

Test Condition		Conducted Power (dBm)	Power Error (dB)
Temperature (°C)	Voltage (V)		
T _{nor} (+25)	DC 3.7	29.63	-0.37
T _{min} (0)	DC 3.15	29.60	-0.40
	DC 3.7	29.52	-0.48
T _{max} (+40)	DC 3.15	29.66	-0.34
	DC 3.7	29.70	-0.30
Nominal Power= 30dBm; Limit n=±1.5 dB and Limit e=+2.0 dB & -3.0 dB			
Result		Pass	

469.95MHZ of 12.5 KHz Channel Separation

Test Condition		Conducted Power (dBm)	Power Error (dB)
Temperature (°C)	Voltage (V)		
T _{nor} (+25)	DC 3.7	29.61	-0.39
T _{min} (0)	DC 3.15	29.59	-0.41
	DC 3.7	29.73	-0.27
T _{max} (+40)	DC 3.15	29.73	-0.27
	DC 3.7	29.54	-0.46
Nominal Power= 30dBm; Limit n=±1.5 dB and Limit e=+2.0 dB & -3.0 dB			
Result		Pass	

High power

400.05MHZ of 25KHz Channel Separation

Test Condition		Conducted Power (dBm)	Power Error (dB)
Temperature (°C)	Voltage (V)		
T _{nor} (+25)	DC 3.7	36.74	-0.26
T _{min} (0)	DC 3.15	36.40	-0.45
	DC 3.7	36.60	-0.40
T _{max} (+40)	DC 3.15	36.66	-0.34
	DC 3.7	36.56	-0.44
Nominal Power= 36.99dBm; Limit n=±1.5 dB and Limit e=+2.0 dB & -3.0 dB			
Result		Pass	

417.00MHZ of 25KHz Channel Separation

Test Condition		Conducted Power (dBm)	Power Error (dB)
Temperature (°C)	Voltage (V)		
T _{nor} (+25)	DC 3.7	36.76	-0.24
T _{min} (0)	DC 3.15	36.66	-0.34
	DC 3.7	36.77	-0.23
T _{max} (+40)	DC 3.15	36.40	-0.45
	DC 3.7	36.71	-0.29
Nominal Power= 36.99dBm; Limit n=±1.5 dB and Limit e=+2.0 dB & -3.0 dB			
Result		Pass	

435.00MHZ of 25KHz Channel Separation

Test Condition		Conducted Power (dBm)	Power Error (dB)
Temperature (°C)	Voltage (V)		
T _{nor} (+25)	DC 3.7	36.62	-0.38
T _{min} (0)	DC 3.15	36.58	-0.42
	DC 3.7	36.61	-0.39
T _{max} (+40)	DC 3.15	36.56	-0.44
	DC 3.7	36.59	-0.41
Nominal Power= 36.99dBm; Limit n=±1.5 dB and Limit e=+2.0 dB & -3.0 dB			
Result		Pass	

452.00MHZ of 25KHz Channel Separation

Test Condition		Conducted Power (dBm)	Power Error (dB)
Temperature (°C)	Voltage (V)		
T _{nor} (+25)	DC 3.7	36.78	-0.22
T _{min} (0)	DC 3.15	36.60	-0.40
	DC 3.7	36.54	-0.46
T _{max} (+40)	DC 3.15	36.54	-0.46
	DC 3.7	36.60	-0.40
Nominal Power= 36.99dBm; Limit n=±1.5 dB and Limit e=+2.0 dB & -3.0 dB			
Result		Pass	

469.95 of 25KHz Channel Separation

Test Condition		Conducted Power (dBm)	Power Error (dB)
Temperature (°C)	Voltage (V)		
T _{nor} (+25)	DC 3.7	36.71	-0.29
T _{min} (0)	DC 3.15	36.63	-0.37
	DC 3.7	36.40	-0.45
T _{max} (+40)	DC 3.15	36.65	-0.35
	DC 3.7	36.61	-0.39
Nominal Power= 36.99dBm; Limit n=±1.5 dB and Limit e=+2.0 dB & -3.0 dB			
Result		Pass	

Low power

400.05MHZ of 25KHz Channel Separation

Test Condition		Conducted Power (dBm)	Power Error (dB)
Temperature (°C)	Voltage (V)		
T _{nor} (+25)	DC 3.7	29.66	-0.34
T _{min} (0)	DC 3.15	29.67	-0.33
	DC 3.7	29.62	-0.38
T _{max} (+40)	DC 3.15	29.78	-0.22
	DC 3.7	29.72	-0.28
Nominal Power= 30dBm; Limit n=±1.5 dB and Limit e=+2.0 dB & -3.0 dB			
Result		Pass	

417.00MHZ of 25KHz Channel Separation

Test Condition		Conducted Power (dBm)	Power Error (dB)
Temperature (°C)	Voltage (V)		
T _{nor} (+25)	DC 3.7	29.60	-0.40
T _{min} (0)	DC 3.15	29.69	-0.31
	DC 3.7	29.64	-0.36
T _{max} (+40)	DC 3.15	29.79	-0.21
	DC 3.7	29.74	-0.26
Nominal Power= 30dBm; Limit n=±1.5 dB and Limit e=+2.0 dB & -3.0 dB			
Result		Pass	

435.00MHZ of 25KHz Channel Separation

Test Condition		Conducted Power (dBm)	Power Error (dB)
Temperature (°C)	Voltage (V)		
T _{nor} (+25)	DC 3.7	29.61	-0.39
T _{min} (0)	DC 3.15	29.70	-0.30
	DC 3.7	29.72	-0.28
T _{max} (+40)	DC 3.15	29.68	-0.32
	DC 3.7	29.71	-0.29
Nominal Power= 30dBm; Limit n=±1.5 dB and Limit e=+2.0 dB & -3.0 dB			
Result		Pass	

452.00MHZ of 25KHz Channel Separation

Test Condition		Conducted Power (dBm)	Power Error (dB)
Temperature (°C)	Voltage (V)		
T _{nor} (+25)	DC 3.7	29.61	-0.39
T _{min} (0)	DC 3.15	29.57	-0.43
	DC 3.7	29.50	-0.50
T _{max} (+40)	DC 3.15	29.40	-0.45
	DC 3.7	29.70	-0.30
Nominal Power= 30dBm; Limit n=±1.5 dB and Limit e=+2.0 dB & -3.0 dB			
Result		Pass	

469.95MHZ of 25KHz Channel Separation

Test Condition		Conducted Power (dBm)	Power Error (dB)
Temperature (°C)	Voltage (V)		
T _{nor} (+25)	DC 3.7	29.64	-0.36
T _{min} (0)	DC 3.15	29.62	-0.38
	DC 3.7	29.57	-0.43
T _{max} (+40)	DC 3.15	29.76	-0.24
	DC 3.7	29.50	-0.50
Nominal Power= 30dBm; Limit n=±1.5 dB and Limit e=+2.0 dB & -3.0 dB			
Result		Pass	

7.3. TRANSMITTER FREQUENCY DEVIATION

TEST LIMIT

ETSI EN 300 086 (V2.1.2) Sub-clause 7.4.3.1

For the definition and the measuring method see clause 7.4.2. The maximum permissible frequency deviation for modulation frequencies from the lowest frequency transmitted (f_1) by the equipment (as declared by the manufacturer) up to (f_2) shall be as given in table 3.

Channel separation(kHz)	Maximum permissible frequency deviation(kHz)
12,5	$\pm 2,5$
20	$\pm 4,0$
25	$\pm 5,0$

ETSI EN 300 086 (V2.1.2) Sub-clause 7.4.3.2

For the definition and the measuring method see clause 7.4.2. The frequency deviation at modulation frequencies between 3,0 kHz (for equipment operating with 20 kHz or 25 kHz channel separations) and 2,40 kHz (for equipment operating with 12,5 kHz channel separation) and 6,0 kHz shall not exceed the frequency deviation at a modulation frequency of 3,0 kHz/2,40 kHz. At 6,0 kHz the deviation shall be not more than 30,0 % of the maximum permissible frequency deviation.

The frequency deviation at modulation frequencies between 6,0 kHz and a frequency equal to the channel separation for which the equipment is intended shall not exceed that given by a linear representation of the frequency deviation (dB) relative to the modulation frequency, starting at the 6,0 kHz limit and having a slope of -14,0 dB per octave. These limits are illustrated in following figure

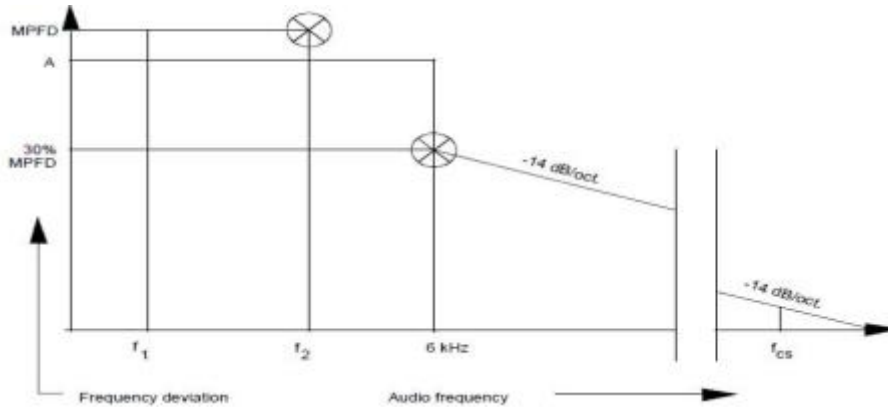

TEST CONFIGURATION

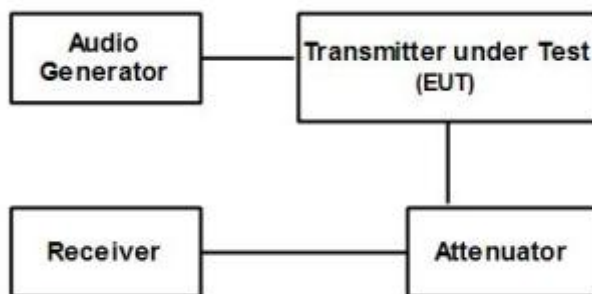

TEST PROCEDURE

Please refer to ETSI EN 300 086 (V.2.1.2) Sub-clause 5.3 for the test conditions.
Please refer to ETSI EN 300 086 (V.2.1.2) Sub-clause 7.4.2 for the measurement method.

TEST RESULTS

Sub-clause 7.4.3.1

High power

12.5 KHz Channel Separation

Frequency (Hz)	Frequency deviation(KHz)		
	400.05	435.00	469.95
300	2.09	1.98	2.12
400	2.02	2.02	2.15
500	1.99	1.92	2.02
600	2.03	1.97	2
700	2	1.85	2
800	1.95	1.81	1.92
900	1.86	1.75	1.82
1000	1.92	1.7	1.73
1200	1.74	1.75	1.6
1400	1.76	1.58	1.62
1600	1.7	1.5	1.46
1800	1.65	1.46	1.35
2000	1.65	1.45	1.4
2200	1.49	1.31	1.27
2400	1.45	1.3	1.2
2600	1.47	1.12	1.2
2800	1.33	1.09	1.09
3000	1.3	0.96	1.15
3500	1.16	0.96	1.04
4000	1.09	0.9	0.98
4500	0.95	0.84	0.91
5000	0.83	0.85	0.91
6000	0.79	0.8	0.86
7000	0.64	0.69	0.67
8000	0.62	0.61	0.6
9000	0.5	0.40	0.49
10000	0.39	0.42	0.4
11000	0.35	0.4	0.41
12000	0.24	0.26	0.31
12500	0.22	0.15	0.21
Limit: ± 2.5 KHz Test Result: PASS			

High power

Low

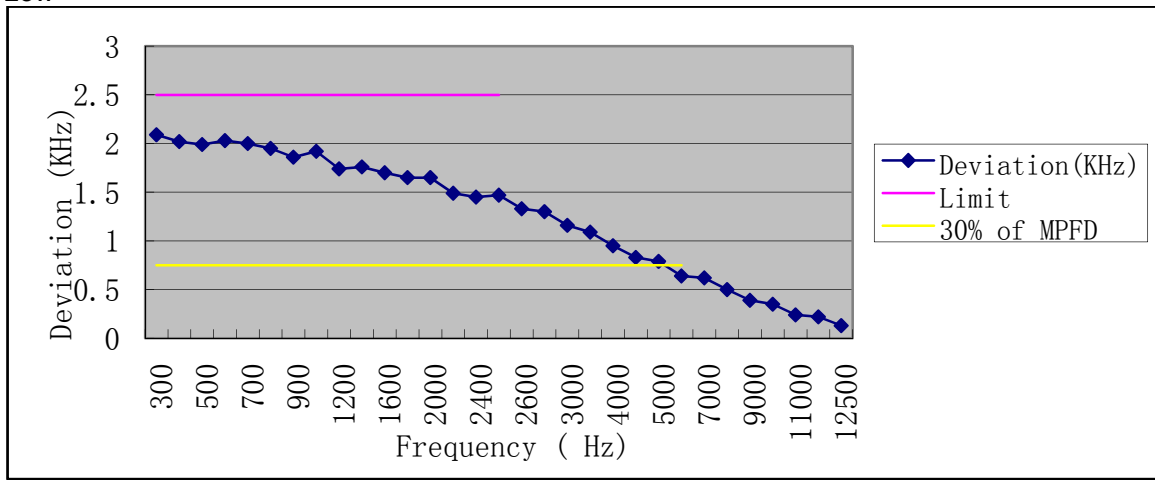

Middle

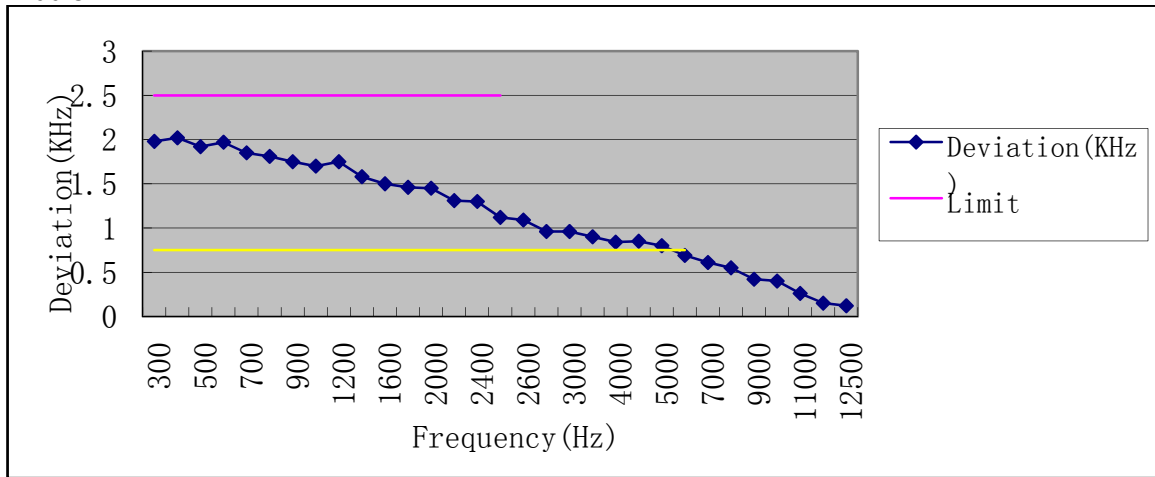

High

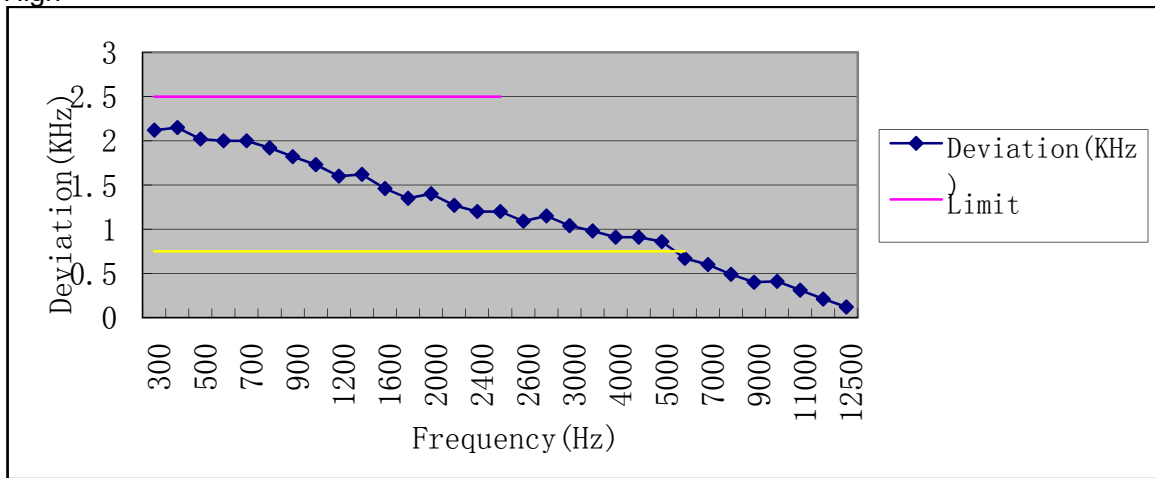

25KHz Channel Separation

Frequency (Hz)	Frequency deviation(KHz)		
	400.05	435.00	469.95
300	4.18	4.58	4.48
400	4.12	4.2	4.32
500	4.18	4.2	3.97
600	3.95	4.06	4
700	3.75	4.12	3.97
800	3.72	3.85	3.86
900	3.66	3.84	3.8
1000	3.61	3.56	3.76
1200	3.49	3.45	3.61
1400	3.41	3.46	3.56
1600	3.25	3.3	3.21
1800	3.08	3.5	3.15
2000	2.94	3.13	2.88
2200	2.92	2.92	3.02
2400	2.86	2.87	2.82
2600	2.65	2.76	2.64
2800	2.46	2.40	2.63
3000	2.38	2.35	2.42
3500	2.21	2.17	2.21
4000	1.97	2.05	2.25
4500	1.75	1.97	2.13
5000	1.40	1.72	1.78
6000	1.54	1.62	1.58
7000	1.56	1.41	1.41
8000	1.23	1.15	1.19
9000	0.97	1.02	1.07
10000	0.78	0.85	0.88
11000	0.44	0.64	0.51
12000	0.49	0.54	0.48
12500	0.32	0.42	0.36
Limit: ± 5 KHz Test Result: PASS			

High power

Low

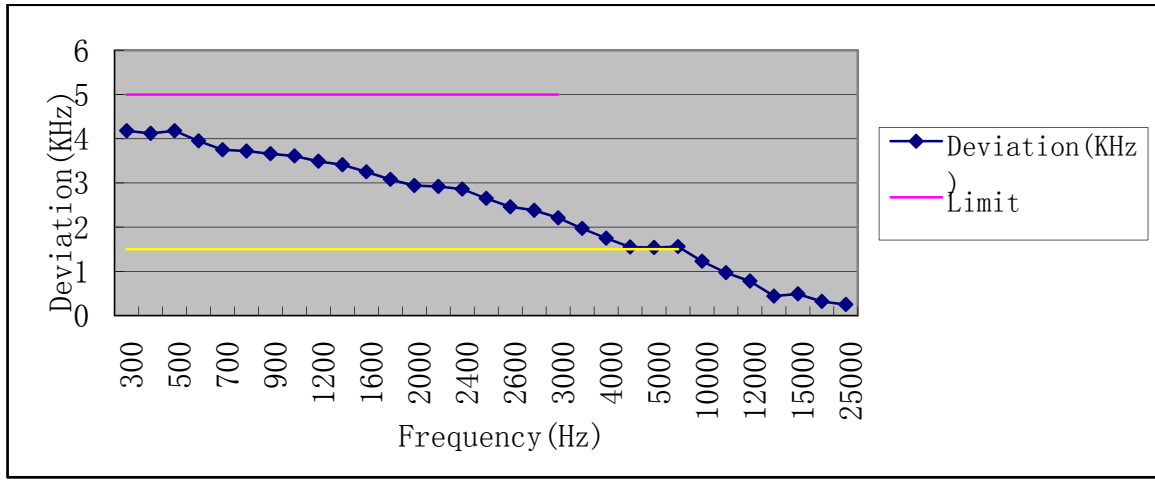

Middle

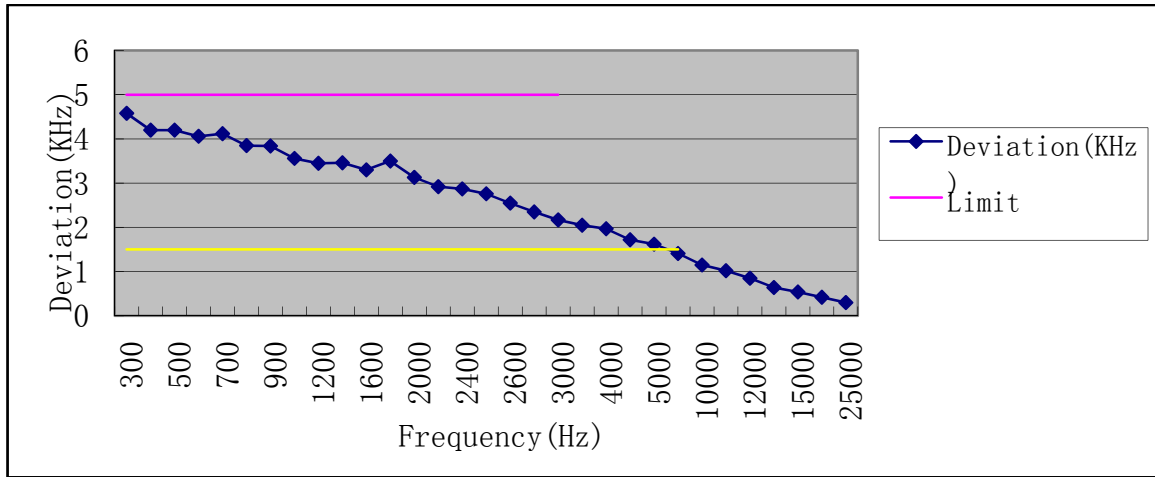

High

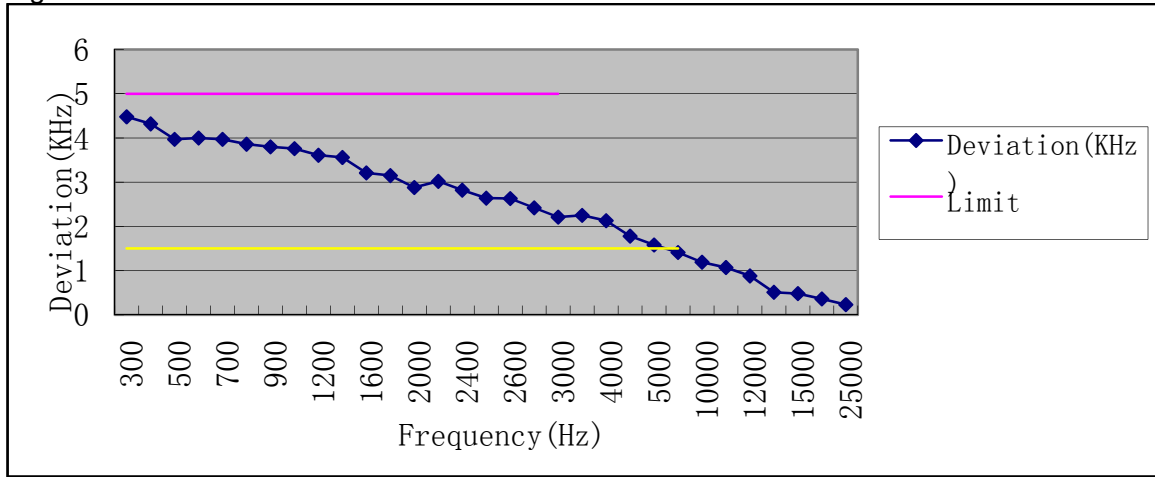

7.4. ADJACENT AND ALTERNATE CHANNEL POWER

LIMIT

ETSI EN 300 086 (V2.1.2) Sub-clause 7.5.3

The adjacent and alternate channel power as defined in ETSI EN 300 086 Sub-clause 7.5.3. For a channel separation of 12,5 kHz, 20 kHz and 25 kHz, the adjacent channel power shall not exceed a value of 60,0 dB below the transmitter power (conducted) without the need to be below 0,2 μ W (-37 dBm).

For a channel separation of 12,5 kHz, 20 kHz and 25 kHz, the alternate channel power shall not exceed a value of 70,0 dB below the transmitter power (conducted) without the need to be below 0,2 μ W (-37 dBm).

TEST CONFIGURATION

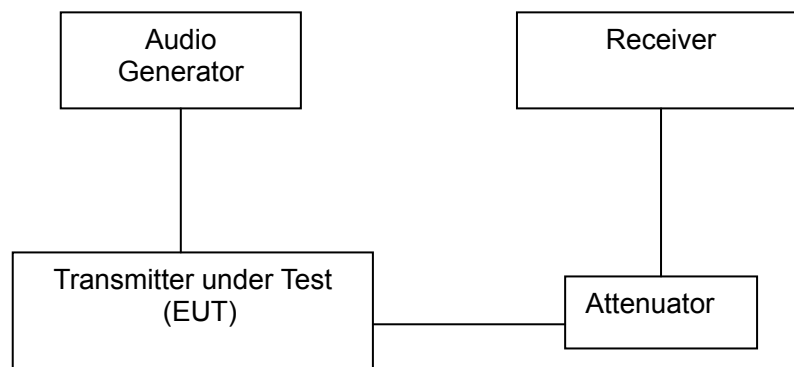

TEST PROCEDURE

1. Please refer to ETSI EN 300 086 (V.2.1.2) Sub-clause 5.3 for the test conditions.
2. Please refer to ETSI EN 300 086 (V.2.1.2) Sub-clause 7.5.2 for the measurement method.

TEST RESULTS

High Power

400.05MHZ of 12.5 KHz Channel Separation

Test Condition		channel	Measurement Offset	Reading (dBc)	limit (dB)
Temperature (°C)	Voltage (V)				
T _{nor} (+25)	3.7	Adjacent	+8.25KHz	-69.41	≤-60
			+8.25KHz	-67.03	≤-60
		Alternate	+20.75KHz	-74.62	≤-70
			+20.75KHz	-73.52	≤-70
Result		Pass			

417.00MHZ of 12.5 KHz Channel Separation

Test Condition		channel	Measurement Offset	Reading (dBc)	limit (dB)
Temperature (°C)	Voltage (V)				
T _{nor} (+25)	3.7	Adjacent	+8.25KHz	-69.93	≤-60
			+8.25KHz	-67.54	≤-60
		Alternate	+20.75KHz	-74.21	≤-70
			+20.75KHz	-73.36	≤-70
Result		Pass			

435.00MHZ of 12.5 KHz Channel Separation

Test Condition		channel	Measurement Offset	Reading (dBc)	limit (dB)
Temperature (°C)	Voltage (V)				
T _{nor} (+25)	3.7	Adjacent	+8.25KHz	-69.96	≤-60
			+8.25KHz	-67.48	≤-60
		Alternate	+20.75KHz	-74.21	≤-70
			+20.75KHz	-73.40	≤-70
Result		Pass			

452.00MHZ of 12.5 KHz Channel Separation

Test Condition		channel	Measurement Offset	Reading (dBc)	limit (dB)
Temperature (°C)	Voltage (V)				
T _{nor} (+25)	3.7	Adjacent	+8.25KHz	-69.14	≤-60
			+8.25KHz	-67.36	≤-60
		Alternate	+20.75KHz	-74.21	≤-70
			+20.75KHz	-73.90	≤-70
Result		Pass			

469.95MHZ of 12.5 KHz Channel Separation

Test Condition		channel	Measurement Offset	Reading (dBc)	limit (dB)
Temperature (°C)	Voltage (V)				
T _{nor} (+25)	3.7	Adjacent	+8.25KHz	-69.58	≤-60
			+8.25KHz	-67.62	≤-60
		Alternate	+20.75KHz	-74.00	≤-70
			+20.75KHz	-73.41	≤-70
Result		Pass			

Low Power

400.05MHZ of 12.5 KHz Channel Separation

Test Condition		channel	Measurement Offset	Reading (dBc)	limit (dB)
Temperature (°C)	Voltage (V)				
T _{nor} (+25)	3.7	Adjacent	+8.25KHz	-68.69	≤-60
			+8.25KHz	-67.32	≤-60
		Alternate	+20.75KHz	-74.14	≤-70
			+20.75KHz	-73.85	≤-70
Result		Pass			

417.00MHZ of 12.5 KHz Channel Separation

Test Condition		channel	Measurement Offset	Reading (dBc)	limit (dB)
Temperature (°C)	Voltage (V)				
T _{nor} (+25)	3.7	Adjacent	+8.25KHz	-69.69	≤-60
			+8.25KHz	-67.154	≤-60
		Alternate	+20.75KHz	-75.21	≤-70
			+20.75KHz	-73.80	≤-70
Result		Pass			

435.00MHZ of 12.5 KHz Channel Separation

Test Condition		channel	Measurement Offset	Reading (dBc)	limit (dB)
Temperature (°C)	Voltage (V)				
T _{nor} (+25)	3.7	Adjacent	+8.25KHz	-69.14	≤-60
			+8.25KHz	-67.32	≤-60
		Alternate	+20.75KHz	-74.69	≤-70
			+20.75KHz	-73.37	≤-70
Result		Pass			

452.00MHZ of 12.5 KHz Channel Separation

Test Condition		channel	Measurement Offset	Reading (dBc)	limit (dB)
Temperature (°C)	Voltage (V)				
T _{nor} (+25)	3.7	Adjacent	+8.25KHz	-69.32	≤-60
			+8.25KHz	-67.69	≤-60
		Alternate	+20.75KHz	-75.14	≤-70
			+20.75KHz	-73.85	≤-70
Result		Pass			

469.95MHZ of 12.5 KHz Channel Separation

Test Condition		channel	Measurement Offset	Reading (dBc)	limit (dB)
Temperature (°C)	Voltage (V)				
T _{nor} (+25)	3.7	Adjacent	+8.25KHz	-69.48	≤-60
			+8.25KHz	-67.96	≤-60
		Alternate	+20.75KHz	-74.58	≤-70
			+20.75KHz	-73.32	≤-70
Result		Pass			

High Power

400.05MHZ of 25KHz Channel Separation

Test Condition		channel	Measurement Offset	Reading (dBc)	limit (dB)
Temperature (°C)	Voltage (V)				
T _{nor} (+25)	3.7	Adjacent	+17KHz	-69.10	≤-60
			+17KHz	-67.36	≤-60
		Alternate	+42KHz	-74.96	≤-70
			+42KHz	-73.25	≤-70
Result		Pass			

417.00MHZ of 25KHz Channel Separation

Test Condition		channel	Measurement Offset	Reading (dBc)	limit (dB)
Temperature (°C)	Voltage (V)				
T _{nor} (+25)	3.7	Adjacent	+17KHz	-69.03	≤-60
			+17KHz	-67.25	≤-60
		Alternate	+42KHz	-74.94	≤-70
			+42KHz	-73.26	≤-70
Result		Pass			

435.00MHZ of 25KHz Channel Separation

Test Condition		channel	Measurement Offset	Reading (dBc)	limit (dB)
Temperature (°C)	Voltage (V)				
T _{nor} (+25)	3.7	Adjacent	+17KHz	-69.23	≤-60
			+17KHz	-67.14	≤-60
		Alternate	+42KHz	-74.46	≤-70
			+42KHz	-73.57	≤-70
Result		Pass			

452.00MHZ of 25KHz Channel Separation

Test Condition		channel	Measurement Offset	Reading (dBc)	limit (dB)
Temperature (°C)	Voltage (V)				
T _{nor} (+25)	3.7	Adjacent	+17KHz	-69.31	≤-60
			+17KHz	-67.27	≤-60
		Alternate	+42KHz	-74.66	≤-70
			+42KHz	-73.05	≤-70
Result		Pass			

469.95MHZ of 25KHz Channel Separation

Test Condition		channel	Measurement Offset	Reading (dBc)	limit (dB)
Temperature (°C)	Voltage (V)				
T _{nor} (+25)	3.7	Adjacent	+17KHz	-69.84	≤-60
			+17KHz	-67.64	≤-60
		Alternate	+42KHz	-74.35	≤-70
			+42KHz	-73.18	≤-70
Result		Pass			

Low Power

400.05MHZ of 25KHz Channel Separation

Test Condition		channel	Measurement Offset	Reading (dBc)	limit (dB)
Temperature (°C)	Voltage (V)				
T _{nor} (+25)	3.7	Adjacent	+17KHz	-68.50	≤-60
			+17KHz	-67.87	≤-60
		Alternate	+42KHz	-74.32	≤-70
			+42KHz	-73.56	≤-70
Result		Pass			

417.00MHZ of 25KHz Channel Separation

Test Condition		channel	Measurement Offset	Reading (dBc)	limit (dB)
Temperature (°C)	Voltage (V)				
T _{nor} (+25)	3.7	Adjacent	+17KHz	-69.47	≤-60
			+17KHz	-67.51	≤-60
		Alternate	+42KHz	-75.32	≤-70
			+42KHz	-73.11	≤-70
Result		Pass			

435.00MHZ of 25KHz Channel Separation

Test Condition		channel	Measurement Offset	Reading (dBc)	limit (dB)
Temperature (°C)	Voltage (V)				
T _{nor} (+25)	3.7	Adjacent	+17KHz	-69.47	≤-60
			+17KHz	-67.54	≤-60
		Alternate	+42KHz	-74.85	≤-70
			+42KHz	-73.41	≤-70
Result		Pass			

452.00MHZ of 25KHz Channel Separation

Test Condition		channel	Measurement Offset	Reading (dBc)	limit (dB)
Temperature (°C)	Voltage (V)				
T _{nor} (+25)	3.7	Adjacent	+17KHz	-69.62	≤-60
			+17KHz	-67.96	≤-60
		Alternate	+42KHz	-75.14	≤-70
			+42KHz	-73.08	≤-70
Result		Pass			

469.95MHZ of 25KHz Channel Separation

Test Condition		channel	Measurement Offset	Reading (dBc)	limit (dB)
Temperature (°C)	Voltage (V)				
T _{nor} (+25)	3.7	Adjacent	+17KHz	-69.66	≤-60
			+17KHz	-67.14	≤-60
		Alternate	+42KHz	-74.05	≤-70
			+42KHz	-73.99	≤-70
Result		Pass			

7.5. TRANSMITTER UNWANTED EMISSIONS IN THE SPURIOUS

TEST LIMIT

ETSI EN 300 086 (V2.1.2) Sub-clause 7.6

Radiated Spurious emission as defined in ETSI EN 300 086 Sub-clause 7.6.4, the power of any spurious emission shall not exceed the values given in table 5a and table 5b

Table 5a: Conducted emissions

Frequency range	Tx operating	Tx standby
9 kHz to 1 GHz	0,25 μ W (-36 dBm)	2,0 nW (-57 dBm)
above 1 GHz to 4 GHz, or above 1 GHz to 12,75 GHz	1,00 μ W (-30 dBm)	20 nW (-47 dBm)

Table 5b: Radiated emissions

Frequency range	Tx operating	Tx standby
30 MHz to 1 GHz	0,25 μ W (-36 dBm)	2,0 nW (-57 dBm)
above 1 GHz to 4 GHz, or above 1 GHz to 12,75 GHz	1,00 μ W (-30 dBm)	20 nW (-47 dBm)

In the case of radiated measurements for hand portable stations the following conditions apply:

- for equipment with an internal integral antenna, the normal antenna shall remain connected;
- for equipment with an external antenna connector, an artificial antenna (see clause 6.3) shall be connected to the connector for the test.

TEST CONFIGURATION

Conducted measurement:

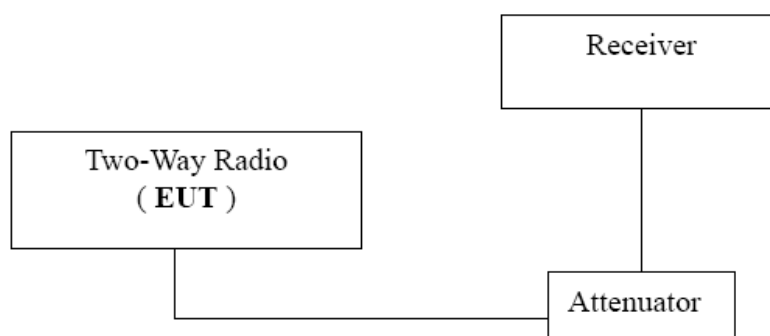

Radiated measurement:

Below 1GHz

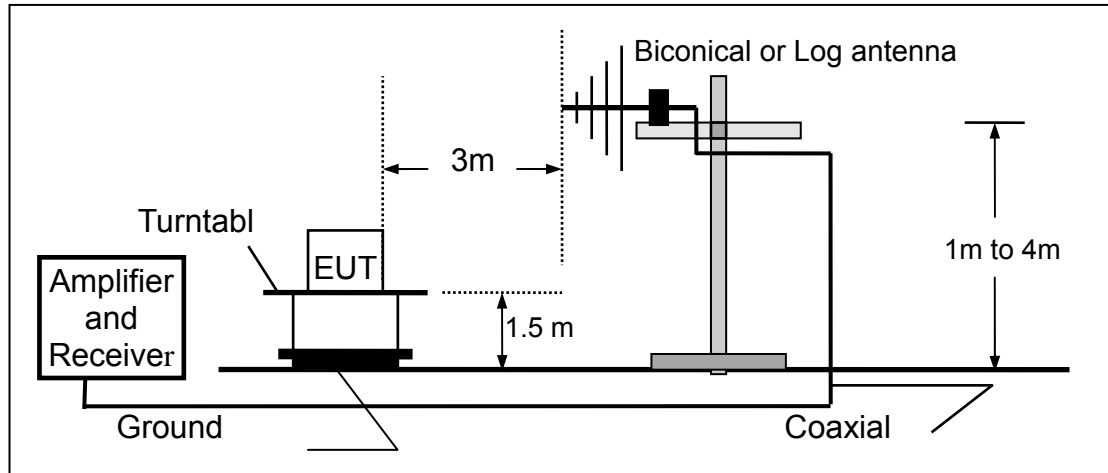

Above 1GHz

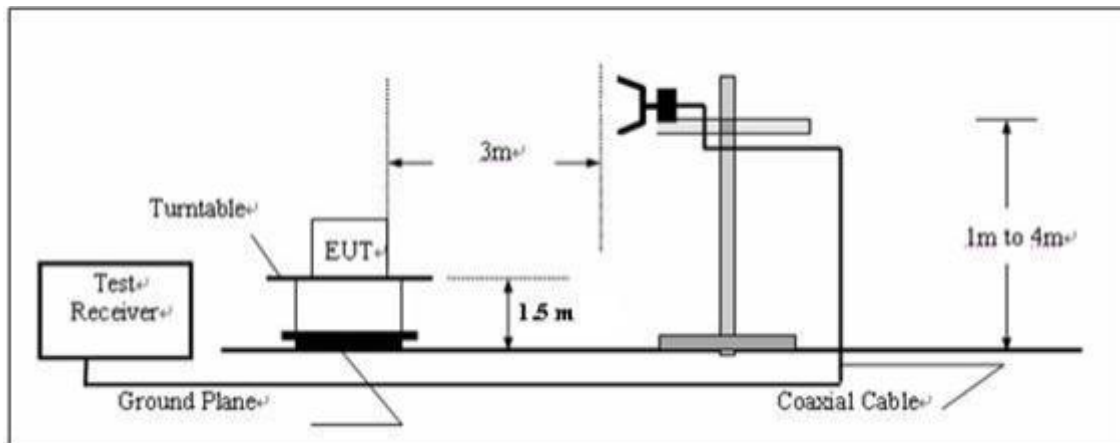

TEST PROCEDURE

1. Please refer to ETSI EN 300 086 (V.2.1.2) Sub-clause 5.3 for the test conditions.
2. Please refer to ETSI EN 300 086 (V.2.1.2) Sub-clause 7.6.2 and 7.6.3 for the measurement method.

Remark

1. During the test, pre-scan all the test modes, and found the worse case and its worse test data was showed as the follow

TEST RESULTS

Conducted measurement (9 KHz to 4 GHz) ---PASS

NO.	Frequency	Measurement Bandwidth	Emissions Level	Limit	Margin
	MHz	KHz	dBm	dBm	dB
400.50MHz @ 25 KHz Channel Separation					
1	452.6	100	-44.20	-36	-8.20
2	647.5	100	-49.58	-36	-13.58
3	1775.1	1000	-59.65	-30	-23.65
4	other	\	\	\	\
440.00MHz @ 25 KHz Channel Separation					
1	456.3	100	-41.03	-36	-5.03
2	635.5	100	-52.36	-36	-16.36
3	1821.8	1000	-42.76	-30	-22.76
4	other	\	\	\	\
479.95MHz @ 25 KHz Channel Separation					
1	468.0	100	-44.15	-36	-8.15
2	642.2	100	-52.30	-36	-16.30
3	1818.5	1000	-60.59	-30	-24.59
4	other	\	\	\	\
Measurement uncertainty:±3.2dB					

Notes:

"\ " in the table above means that the emissions are too small to be measured and are at least 20 dB below the limit

Radiated measurement (30 MHz to 4 GHz) ---PASS

**High Power-TX operating mode
469.95MHz is the worst case for 25 KHz Channel Separation**

Frequency (MHz)	Reading level (dBm)	Antenna Polarization	Correct Factor. (dB)	Emission level (dBm)	Limit (dBm)	Margin (dB)
79.03	-71.30	V	11.15	-60.15	-36	-24.15
325.52	-83.25	V	23.39	-59.86	-36	-23.86
3954.21	-48.14	V	-8.14	-56.28	-30	-26.28
3575.02	-56.90	V	-8.28	-65.18	-30	-35.18
				0		0
57.45	-86.26	H	11.96	-74.3	-36	-38.3
35.98	-102.32	H	24.47	-77.85	-36	-41.85
2025.65	-40.65	H	-6.85	-62.5	-30	-32.5
2787.21	-53.80	H	-8.31	-62.11	-30	-32.11

.Remark:

- (1) Emission Level (dBm) =Reading level +Correct Factor
- (2) Data of measurement within this frequency range shown "--" in the table above means the reading of emissions are attenuated more than 20dB below the permissible limits or the field strength is too small to be measured.
- (3) The Measurement uncertainty value is ± 3.5 dB.

7.6. RECEIVER MAXIMUM USEABLE SENSITIVITY

LIMIT

ETSI EN 300 086(V 2.1.2) Sub-clause 8.1

The spurious radiation of the receiver as defined in ETSI EN 300 086 Sub-clause 8.1.3 . The maximum usable sensitivity shall not exceed an electromotive force (emf) of +6,0 dBμV under normal test conditions, and an emf of +12,0 dBuV under extreme test conditions.

TEST PROCEDURE

1. Please refer to ETSI EN 300 086 (V2.1.2) Sub-clause 8.1.2 for the measurement method.

TEST RESULTS

12.5KHz Channel Separation

Test Condition		Reading(dBc)					Result
Temperature (°C)	Voltage (V)	400.50 MHz	420.05 MHz	440.00 MHz	460.05 MHz	479.95 MHz	
T _{nor} (+25)	DC 3.7	4.03	4.20	4.12	4.63	4.12	PASS
T _{min} (0)	DC 3.15	4.25	4.63	4.36	4.25	4.63	
	DC 3.7	4.97	4.91	4.74	4.98	4.21	
T _{max} (+40)	DC 3.15	4.12	4.12	4.89	4.24	4.69	
	DC 3.7	4.85	4.78	4.54	4.88	4.41	
Limit		Normal=+6dBuV, Extreme=+12dBuV					

25KHz Channel Separation

Test Condition		Reading(dBc)					Result
Temperature (°C)	Voltage (V)	400.50 MHz	420.05 MHz	440.00 MHz	460.05 MHz	479.95 MHz	
T _{nor} (+25)	DC 3.7	4.32	4.14	4.45	4.63	4.21	PASS
T _{min} (0)	DC 3.15	4.02	4.52	4.21	4.26	4.03	
	DC 3.7	4.63	4.32	4.48	4.12	4.14	
T _{max} (+40)	DC 3.15	4.14	4.47	4.36	4.36	4.40	
	DC 3.7	4.95	4.96	4.29	4.45	4.69	
Limit		Normal=+6dBuV, Extreme=+12dBuV					

7.7. RECEIVER CO-CHANNEL REJECTION

TEST LIMIT

ETSI EN 300 086 (V2.1.2) Sub-clause 8.3

Radiated Spurious emission as defined in ETSI EN 300 086 Sub-clause 8.3.3, The value of the co-channel rejection ratio, expressed in dB, at the signal displacements given in the method of measurement, shall be:

- between -8,0 dB and 0 dB, for channel separations of 20 kHz and 25 kHz;
- between -12,0 dB and 0 dB, for channel separations of 12,5 kHz.

TEST PROCEDURE

1. Please refer to ETSI EN 300 086 (V2.1.2) Sub-clause 8.3.2 for the measurement method

TEST RESULTS

25KHz Channel Separation

Test Condition		Reading(dBc)					Result
Temperature (°C)	Voltage (V)	400.50 MHz	420.05 MHz	440.00 MHz	460.05 MHz	479.95 MHz	
T _{nor} (+25)	DC 3.7	-6.32	-6.36	-6.72	-6.41	-6.66	PASS
Limit		-8dB<Reading<0dB					

12.5KHz Channel Separation

Test Condition		Reading(dBc)					Result
Temperature (°C)	Voltage (V)	400.50 MHz	420.05 MHz	440.00 MHz	460.05 MHz	479.95 MHz	
T _{nor} (+25)	DC 3.7	-9.30	-9.45	-9.81	-9.89	-9.29	PASS
Limit		-12dB<Reading<0dB					

7.8. RECEIVER ADJACENT CHANNEL SELECTIVITY

TEST LIMIT

ETSI EN 300 086 (V2.1.2) Sub-clause 8.4

Radiated Spurious emission as defined in ETSI EN 300 086 Sub-clause 8.4.3, The adjacent channel selectivity for different channel separations shall not be less than the values given in table 8.

Table 8: Adjacent channel selectivity

	Channel separation	
	12,5 kHz	20/25 kHz
Normal test conditions	60,0 dB	70,0 dB
Extreme test conditions	50,0 dB	60,0 dB

TEST PROCEDURE

1. Please refer to ETSI EN 300 086 (V2.1.2) Sub-clause 8.4.2 for the measurement method.

TEST RESULTS

12.5 KHz Channel Separation

Test Condition		Reading (dBc)					Result
Temperature (°C)	Voltage (V)	400.50 MHz	420.05 MHz	440.00 MHz	460.05 MHz	479.95 MHz	
T _{nor} (+25)	DC 3.7	66	67	67	67	67	PASS
T _{min} (0)	DC 3.15	66	65	66	65	68	
	DC 3.7	67	66	65	67	67	
T _{max} (+40)	DC 3.15	65	67	66	66	66	
	DC 3.7	64	65	66	68	65	
Limit		Normal=60 dB, Extreme=50dB					

25KHz Channel Separation

Test Condition		Reading (dBc)					Result
Temperature (°C)	Voltage (V)	400.50 MHz	420.05 MHz	440.00 MHz	460.05 MHz	479.95 MHz	
T _{nor} (+25)	DC 3.7	77	77	78	78	78	PASS
T _{min} (0)	DC 3.15	67	66	65	67	67	
	DC 3.7	66	65	67	67	65	
T _{max} (+40)	DC 3.15	65	68	66	66	66	
	DC 3.7	66	67	66	65	67	
Limit		Normal=70 dB, Extreme=60dB					

7.9. RECEIVER SPURIOUS RESPONSE REJECTION

LIMIT

ETSI EN 300 086(V 2.1.2) Sub-clause 8.5

The spurious radiation of the receiver as defined in ETSI EN 300 086 Sub-clause 8.5.4. At any frequency separated from the nominal frequency of the receiver by two channels or more, the spurious response rejection shall not be less than 70,0 dB.

TEST PROCEDURE

1. Please refer to ETSI EN 300 086 (V2.1.2) Sub-clause 8.5.3 for the measurement method.

TEST RESULTS

12.5 KHz Channel Separation

Test Condition		Reading (dBc)	Result
Temperature (°C)	Voltage (V)		
T _{nor} (+25)	DC 3.7	74.32	PASS
Limit		Reading ≥ 70dB	

25 KHz Channel Separation

Test Condition		Reading (dBc)	Result
Temperature (°C)	Voltage (V)		
T _{nor} (+25)	DC 3.7	74.05	PASS
Limit		Reading ≥ 70dB	

7.10. RECEIVER INTER-MODULATION RESPONSE REJECTION

LIMIT

ETSI EN 300 086(V 2.1.2) Sub-clause 8.6

The spurious radiation of the receiver as defined in ETSI EN 300 086 Sub-clause 8.6.3. The intermodulation response rejection ratio shall not be less than 70,0 dB for base station equipment and 65,0 dB for mobile and hand portable equipment.

TEST PROCEDURE

1. Please refer to ETSI EN 300 086 (V2.1.2) Sub-clause 8.6.2 for the measurement method.

TEST RESULTS

12.5 KHz Channel Separation

Test Condition		Reading (dBc)	Result
Temperature (°C)	Voltage (V)		
T _{nor} (+25)	DC 3.7	75.30	PASS
Limit		Reading ≥ 65dB	

25 KHz Channel Separation

Test Condition		Reading (dBc)	Result
Temperature (°C)	Voltage (V)		
T _{nor} (+25)	DC 3.7	75.81	PASS
Limit		Reading ≥ 65dB	

7.11.RECEIVER BLOCKING OR DESENSITIZATION

LIMIT

ETSI EN 300 086(V 2.1.2) Sub-clause 8.7

The spurious radiation of the receiver as defined in ETSI EN 300 086 Sub-clause 8.7.3. The blocking ratio for any frequency within the specified ranges shall not be less than 84,0 dB, except at frequencies on which spurious responses are found.

TEST CONFIGURATION

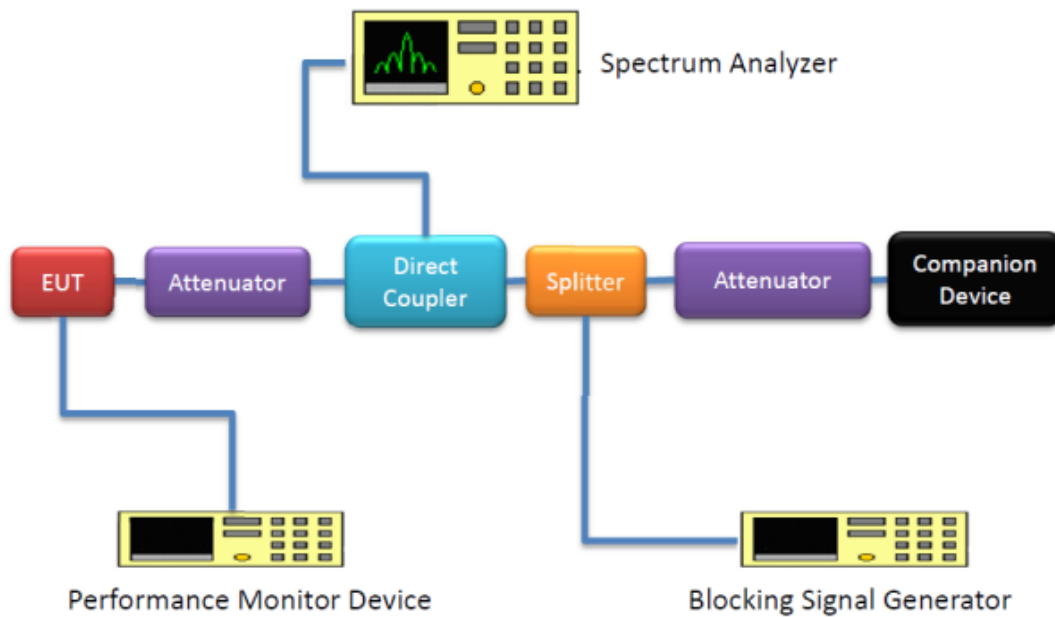

TEST PROCEDURE

1. Please refer to ETSI EN 300 086 (V2.1.2) Sub-clause 8.7.2 for the measurement method.

TEST RESULTS

12.5 KHz Channel Separation

Test Condition		Reading (dBc)	Result
Temperature (°C)	Voltage (V)		
T _{nor} (+25)	DC 3.7	90.14	PASS
Limit		Reading ≥ 84dB	

25 KHz Channel Separation

Test Condition		Reading (dBc)	Result
Temperature (°C)	Voltage (V)		
T _{nor} (+25)	DC 3.7	90.52	PASS
Limit		Reading ≥ 84dB	

7.12.RECEIVER SPURIOUS RADIATIONS

LIMIT

ETSI EN 300 086(V 2.1.2) Sub-clause 8.8

The spurious radiation of the receiver as defined in ETSI EN 300 086 Sub-clause 8.8.4 the power of any spurious radiation shall not exceed the values given in tables 9 and 10.

Table 9: Conducted components

Frequency range	Limit
9 kHz to 1 GHz	2,0 nW (-57 dBm)
above 1 GHz to 4 GHz, or above 1 GHz to 12,75 GHz	20,0 nW (-47 dBm)

Table 10: Radiated components

Frequency range	Limit
30 MHz to 1 GHz	2,0 nW (-57 dBm)
above 1 GHz to 4 GHz	20,0 nW (-47 dBm)

TEST CONFIGURATION

Conducted measurement:

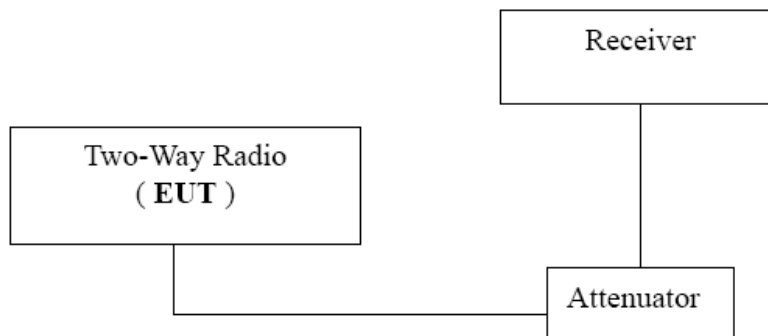

Radiated measurement:

Below 1GHz

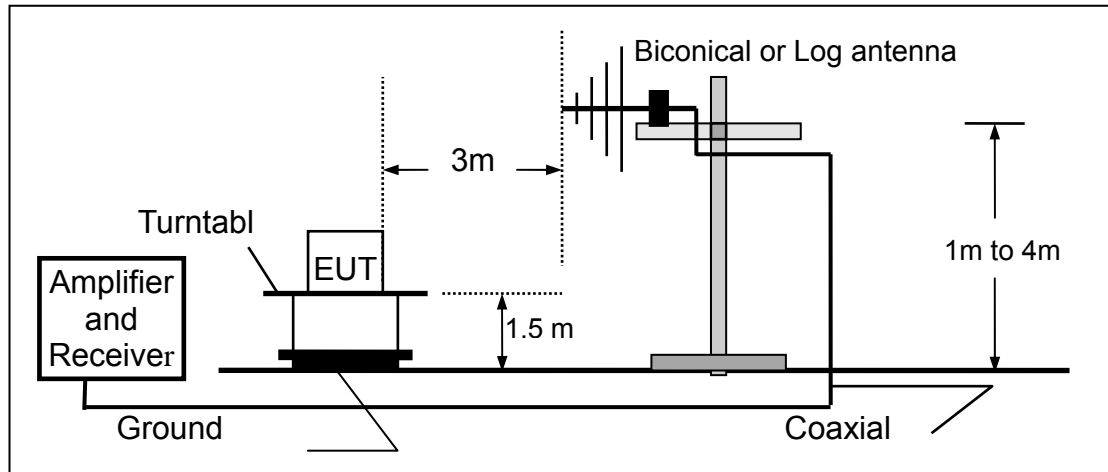

Above 1GHz

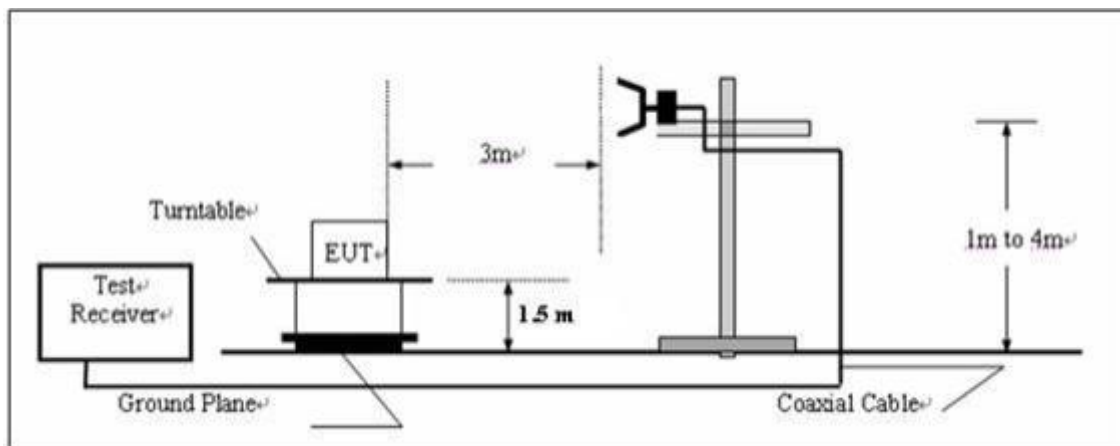

TEST PROCEDURE

1. Please refer to ETSI EN 300 086 (V2.1.2) Sub-clause 8.8.3 for the measurement method.

TEST RESULTS

PASS

measurement (9 KHz to 4 GHz) ---PASS

12.5KHz Channel Separation

Frequency (MHz)	Reading level (dBm)	Antenna Polarization	Correct Factor. (dB)	Emission level (dBm)	Limit (dBm)	Margin (dB)
339.39	-83.25	V	21.96	-61.12	-57	-4.12
518.21	-85.63	V	21.41	-64.05	-57	-7.05
417.51	-86.98	H	20.23	-66.44	-57	-9.44
564.69	-87.78	H	22.61	-65.17	-57	-8.17

25KHz Channel Separation

Frequency (MHz)	Reading level (dBm)	Antenna Polarization	Correct Factor. (dB)	Emission level (dBm)	Limit (dBm)	Margin (dB)
341.39	-83.12	V	21.25	-61.87	-57	-4.87
517.15	-85.63	V	21.98	-63.48	-57	-6.48
416.58	-86.21	H	20.47	-65.63	-57	-8.63
564.20	-87.96	H	22.21	-65.20	-57	-8.20

Note:

1. The Measurement uncertainty value is ± 3.5 dB.

Radiated Emissions Test Setup

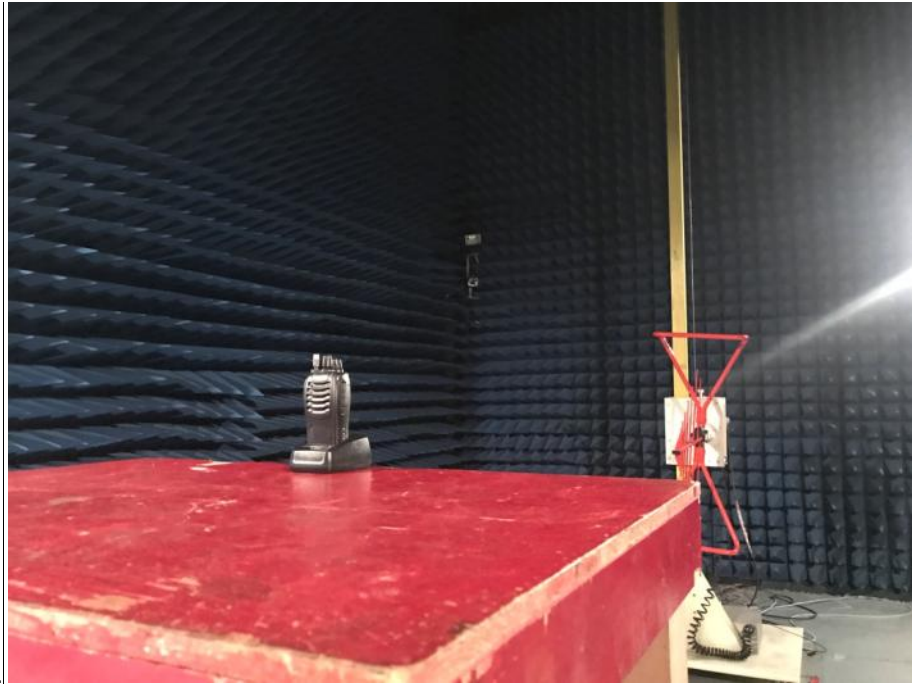

----END OF REPORT----