

## FD-C Series



### Circular Single Blade Externally Resettable Combination Fire and Volume Control Damper

- Conforms to fire damper product standard EN15650
- ES classified fire dampers with reduced smoke leakage characteristics EN 13501-3
- Aerodynamically Air Control tested to BS EN 1751
- Tested installation methods in differing supporting constructions (BS EN 1366-2)
- Integrated volume control capability
- Replaceable fusible link from outside of the ductwork
- Commissioning friendly
- External blade position indicator
- Damper casing sizes and tolerances conform to BS EN 1506



MANUFACTURERS OF AIR, FIRE AND SMOKE CONTROL PRODUCTS



# FD-C Series

## Single Blade Circular Fire Dampers - Introduction



### The FD-C Series

The FD-C Manual Operation Single Blade Fire Damper with volume control facility has been designed specifically for installations where space is at a premium.

The testing and resetting of the damper and thermal fuse external of the duct allows for ease of commissioning and maintenance.

NB: Access panels may be required to comply with DW145 G.3.1.5.

The installation plate, with its engineered installation perforations, acts as a template to allow the marking of the fixing positions on the surface of the structure to which the plate will be affixed, allowing for a quick and efficient install.



### Introduction

#### What is a fire damper and why might they be needed?

The FD-C Series Single Blade Circular Fire Damper is designed to stop the spread of fire through ducts, walls and floors.

The product range has many features and options to meet the requirements of specifiers, contractors, local and national authorities. Dampers are available to suit both low and medium velocity applications.

#### What are the 'E' and 'ES' classifications?

To achieve the classifications to EN13501-3, fire dampers and fire and smoke dampers shall meet product standard 15650 be tested to EN1366-2 where a 300Pa pressure difference is applied across the damper. During the fire test period, the integrity of the seal between the damper and the structure shall not have any gaps larger than 6mm x 150mm. There shall not be any sustained flaming. The largest size of damper to be manufactured for sale as a single section shall be fire tested.

#### E = Integrity

The maximum leakage permissible at 300Pa corrected to 20°C is 360m<sup>3</sup>/hr/m<sup>2</sup> (100 l/s/m<sup>2</sup>) throughout the fire test period.

#### ES = Integrity with Smoke Leakage Performance

The maximum leakage permissible at 300Pa corrected to 20°C is 200m<sup>3</sup>/hr/m<sup>2</sup> (55.5 l/s/m<sup>2</sup>) at ambient prior to the fire test and throughout the fire test period. In addition, for the ES classification to be attained, the smallest damper must also meet the 200m<sup>3</sup>/hr/m<sup>2</sup> maximum ambient leakage with a 300Pa pressure across the damper. (This is equivalent to just 0.55 l/s on a 100 dia. damper).

Fire dampers should be installed as tested.

### FD-C Features and Benefits

- Tested and certified installation variants of the FD-C are available for dry walls, masonry walls and concrete floors.
- All BSB tested installation methods give at least a E90 classification.

### Testing and Conformities

CE marked to EN1366-2

See installation details for full details.

Tested and achieved classification to:

#### ES Classification (BS EN 1366-2/BS EN 13501-3)

- BSB FD-C fitted with Installation Plate
  - ES120 (ve i ↔ O) - Blockwork/Masonry wall
  - ES90 (ve i ↔ O) - Dry Partition wall
  - ES120 (ho i → O) - Concrete floor
  - ES120 (ve i → O) - Batt Wall

#### FD-C Blade leakage (BS EN 1751)

- Class 2

#### FD-C Case leakage

- Eurovent 2.2 Class C

#### Corrosion testing (BRE)

- Tested and satisfies LPS1162
- Complying with test method BS EN 60068-2-11

### Leakage Classification

Blade leakage classification is given numerically 1 - 4 and case leakage classification is given using capital letters A - C of EN1751 (sections C.2 and C.3).

The FD-C series damper meets Class 3 blade leakage section C.2 refers and Class C case leakage section C.3 of the EN1751 standard, section C.2 refers.

Normal operating conditions - not exceeding 1100Pa, Classes A, B & C of DW 144 2016 Specification will apply.

### The FD-C Series Range

The BSB FD-C series is available in the following case diameters:

FD-C100 - 100mm diameter	FD-C200 - 200mm diameter
FD-C125 - 125mm diameter	FD-C250 - 250mm diameter
FD-C150 - 150mm diameter	FD-C300 - 300mm diameter
FD-C160 - 160mm diameter	FD-C315 - 315mm diameter

**Typical Tender/Specification Text**

The BSB FD-C combination Fire and Volume Control Damper shall pass the test requirements stated in EN 1366-2 and conforms to the product standard for fire dampers EN15650.

For maintenance of the integrity of compartmentation the fire damper shall have an E classification to EN 13501-3.

The damper shall have an ES classification complying with EN1366-2 and EN 13501-3 and have a minimum ES90 rating.

Damper casings shall conform to BS EN 1506.

For the protection of escape routes and areas with sleeping risk, the FSD-C fire/smoke damper should be used. Please refer Approved Document B (ADB).

The single blade layered design shall be held open against a torsion spring that is released via a fusible link having an alloy component that melts at 72°C allowing the spring mechanism to close the damper.

The damper assembly and fusible link shall be safely tested and released closed externally to the damper without the need for specialist tools or access panels. NB: Access panels may be required to comply with DW145 G.3.1.5.

The fire damper body shall be stitch welded to meet the air tightness test requirements of HVCA specification. Normal operating conditions - not exceeding 1000Pa, Classes A & B of DW 144 2016 Specification will apply.

The closed blade shall meet the air tightness test requirement of BS EN 1751 Class 2.

The BSB FD-C combination fire and volume control damper shall have a tested or assessed installation method that matches the requirement of the supporting construction. DW145 Method 4 Blockwork Walls, Dry Walls and Concrete Floors refers.

**Micro Switch**

The factory fitted micro switch to provide remote indication of the damper blade status. The micro switch is fitted on the opposite side to the operating handle where a purpose designed cam fitted to the protruding blade operating spindle allows the release of the micro switch actuating lever, allowing the snap action contacts 1NO + 1NC to change state.

Wiring connections are made via M3, 5 terminal screw fixings.

Mechanical life: 1 million cycles

Complies with EN60204 and EN292 standards

**Electrical data:**

Thermal current (Ith): 16A
Rated insulation voltage: 250VAC 300VDC
Protection against short circuits: fuse 10A 500V type gG

**Utilisation categories:**

Alternate current: AC15 (50 ... 60Hz)			
Ue (V)	250		
Ie (A)	5		
Direct current: DC13			
Ue (V)	24	125	250
Ie (A)	4	1,1	0,4

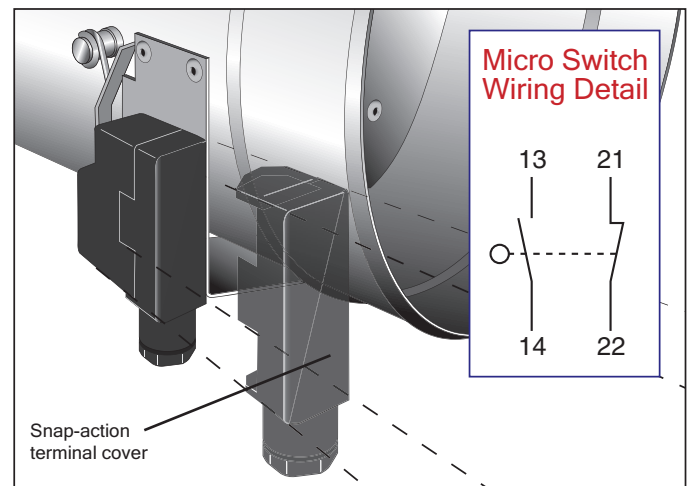

**FD-C Series Dampers - Testing and Maintenance**

FD-C Series dampers are designed for normal dry filtered air systems. A programme of planned inspections should be carried out to include full operational checks, correct interface with, and function of, any control systems, cleaning and light lubrication.

As a guide, this should take place on a maximum of six months intervals.

Reference should be made to BS 9999 for more information.

Records of damper installation and position shall be kept. Records of the condition of the dampers and their functionality/repair etc should be kept as these products come under the requirements of the Regulatory Reform (Fire Safety) Order (RRFSO).

These inspection and maintenance programmes may need to be repeated more regularly if the dampers are exposed to inclement/dusty conditions or fresh air intakes and the frequency of such checks should be reviewed based on site experience.

**Storage**

Dampers received on site should be stored in a purpose made storage area, where they can be protected from moisture, dust and impact damage until required.

**Weight Chart (kg approx.)**

Nom. Dia. (mm)	320mm with inst. plate
100	1.2
125	1.6
150	2.0
160	2.1
200	2.8
250	4.0
300	5.0
315	5.1

**Damper Free Area (fully open)**

Model	Free Area	Model	Free Area
FD-C100	64%	FD-C200	85%
FD-C125	73%	FD-C250	88%
FD-C150	79%	FD-C300	91%
FD-C160	81%	FD-C315	91%



# FD-C Series

## Single Blade Circular Fire Dampers - Product Specification



### Case

Galvanised mild steel to BS EN 10346 DX 51D Z275  $0.8 \pm 0.1$ mm  
Damper casing conforms to BS EN 1506.

### Fusible Link

Fusible link externally replaceable rated at  $72^{\circ}\text{C}$  has been designed to eliminate linear creep of the solder joint. The thermal link is screwed into position via the 12.5mm diameter brass holder activating the locking assembly from outside the case in any position from fully open to fully closed, allowing air balance during the commissioning of the ducted system.

### Handle

The handle is an 8mm dia. preformed 400 series ferritic stainless steel rod that allows the setting of the damper to any set point or fully open position. The blade angle is shown via the graduated affixed label.

### Installation Plate

The installation plate allows the damper to be fixed into place from one side only with no infill material required on the non-handle side. Use either of the two appropriate 5mm dia. corner fixing holes and all of the 5mm dia. mid span fixing holes to secure the plate into position.

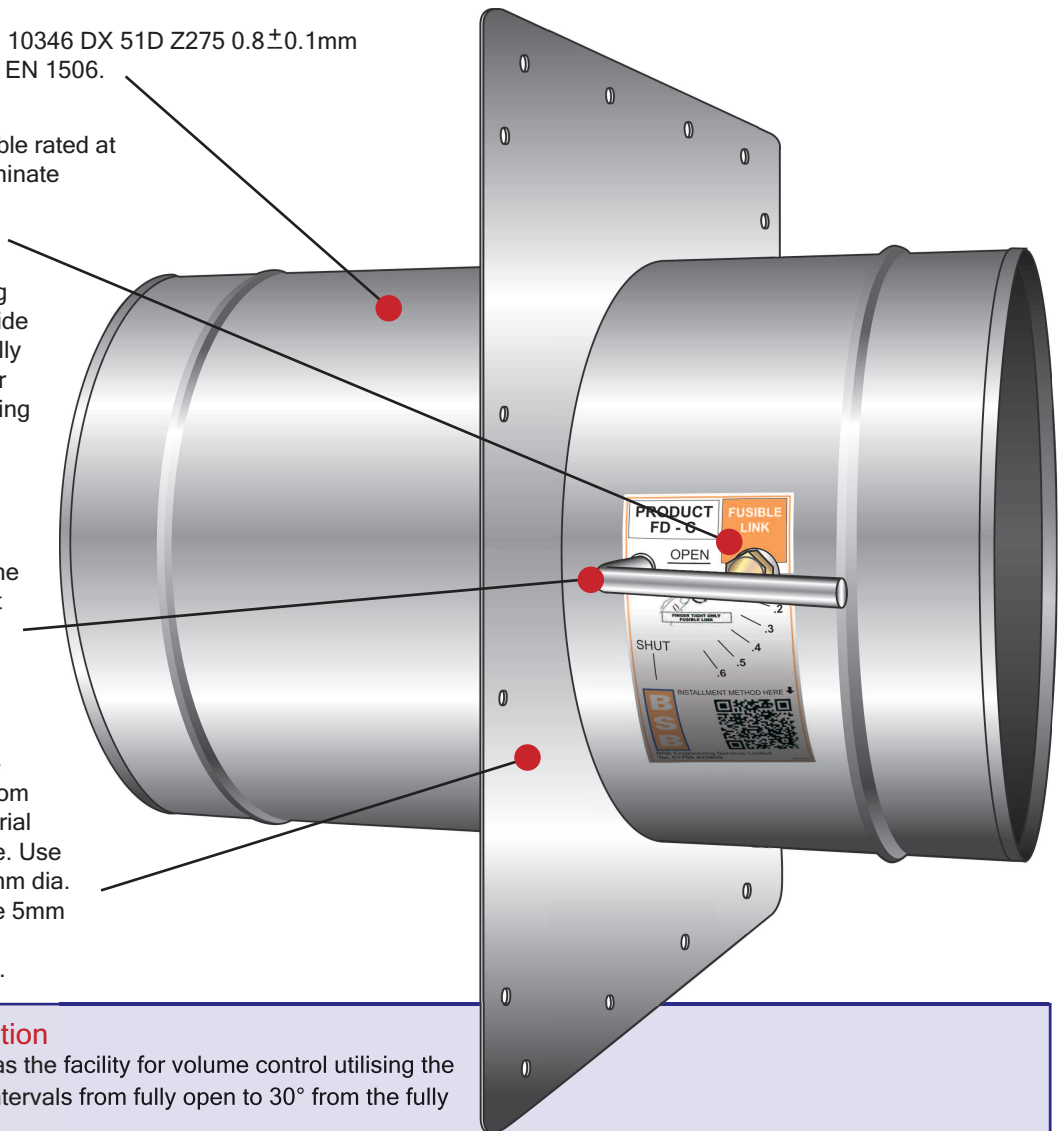

### Volume Control Application

The FD-C manual damper has the facility for volume control utilising the seven presets at  $10^{\circ}$  steps/intervals from fully open to  $30^{\circ}$  from the fully closed position.

The operating handle has been designed to be in line with the blade orientation thus providing an accurate guide to the blade set or released position.

### Blade Seal (patented)

Layered glass woven sheets and central intumescent disc to a patented design that allows the blade assembly to be of minimal thickness, thus minimising pressure loss with fully open damper, and an effective seal when fully closed to comply with EN 1366-2 achieving ES classification.

### Blade

Galvanised 1.2mm one piece circular steel discs either side of the patented seal design providing a 5mm thick assembly affixed by blade brackets to the reset handle.

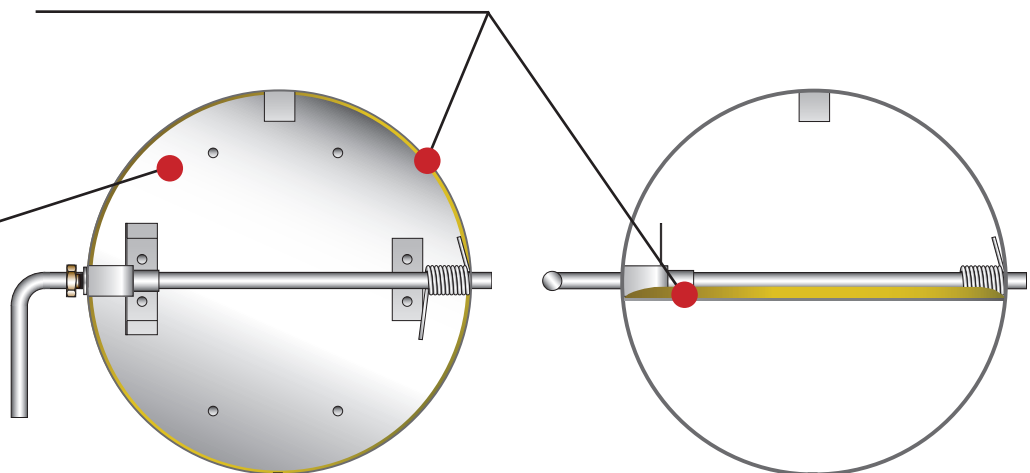

Blade Closed

Blade Open



### The FD-C Series - MANUAL Operation with Installation Plate

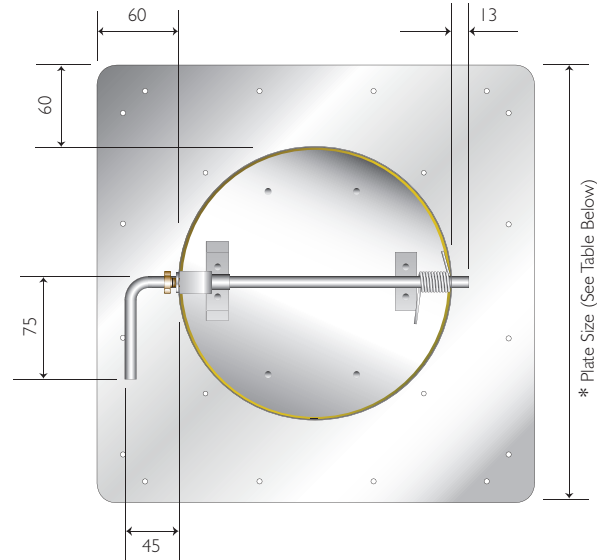
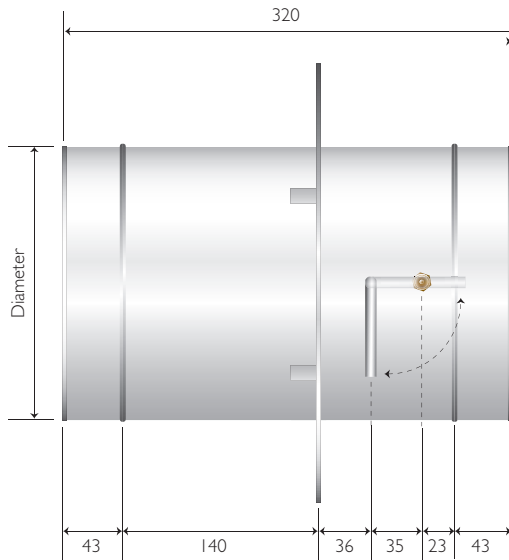

### Installation Plates

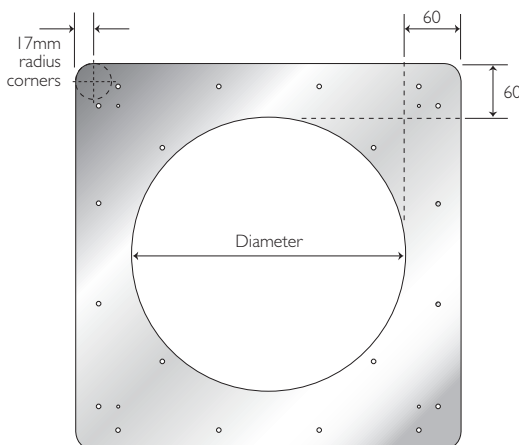

Model	Dia. (mm)	Square Plate Size (mm)
FD-C100	100	220
FD-C125	125	245
FD-C150	150	270
FD-C160	160	280
FD-C200	200	320
FD-C250	250	370
FD-C300	300	420
FD-C315	315	435

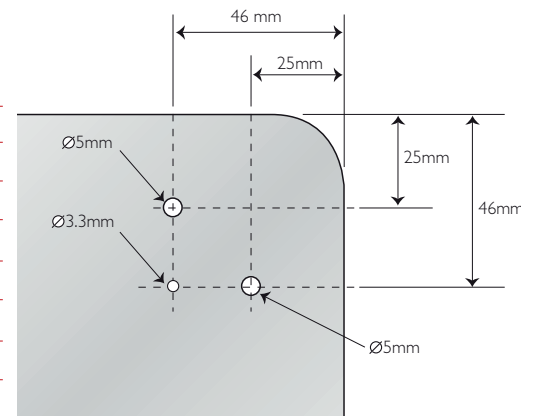

NB: Use either of the two appropriate 5mm dia. corner fixing holes and all of the 5mm dia. mid span fixing holes to secure the plate to the steelwork within the dry wall/into masonry wall/floor.

### Cleats

Rotatable cleats are available as an optional accessory where requested and will be provided factory fitted as shown right.

The FD-C series damper must be installed as per BSB installation, operating and maintenance document to comply with CE marking.

The use of cleats as the sole installation/support method will not comply with CE marking rules.

Where cleats are requested to be fitted and local authority approval has been given, the drop rod system will be the responsibility of others.

### Fixing Kit

Fixing cleat (4) kits are available for retro fixing, please refer to the sales office.

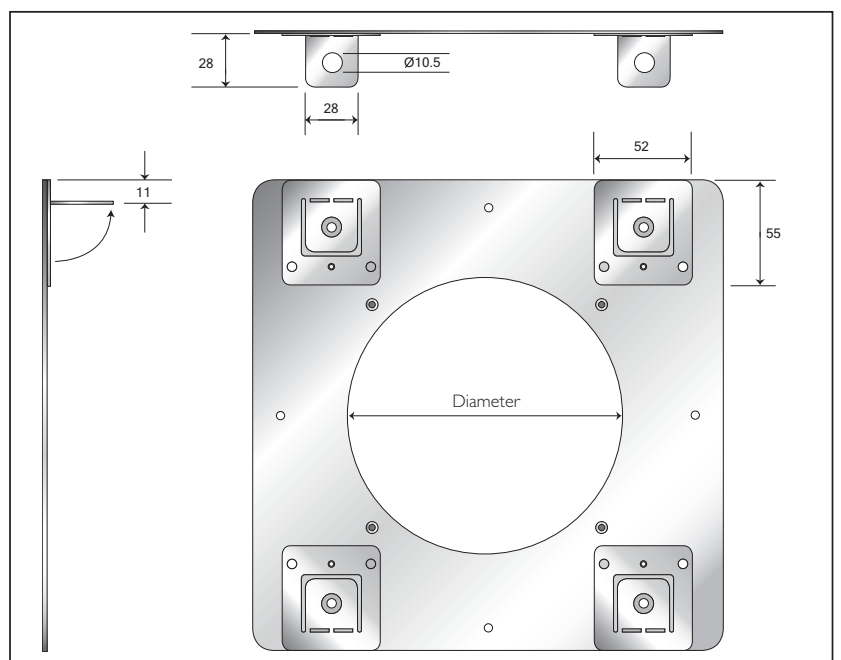

# FD-C Series

## Single Blade Circular Fire Dampers - Rotatable Cleats



### Rotatable Easy Bend Cleats

The optional Rotatable Cleat Easy Fix System will be supplied factory fitted to the FD-C Series dampers.

The installation plate should be fitted to the fire separation barrier to ensure test conformity is maintained. The Easy Bend Cleat is available factory fitted four per plate. The cleats should only be used where the fire separation element is not yet in place, offering a temporary installation support. The cleats must not be the sole independent method of supporting the fire damper.

The cleats can easily be bent out using a flat head screwdriver. Supporting drop rods are used in the normal way.

The cleats can be rotated through 90 degrees to suit handle position where the damper requires to be installed with the handle of either left, right, top or bottom giving full flexibility during installation.

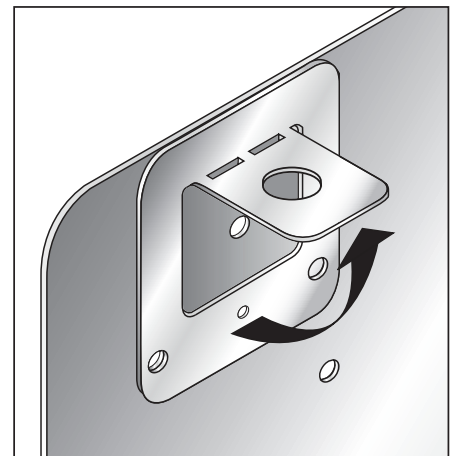
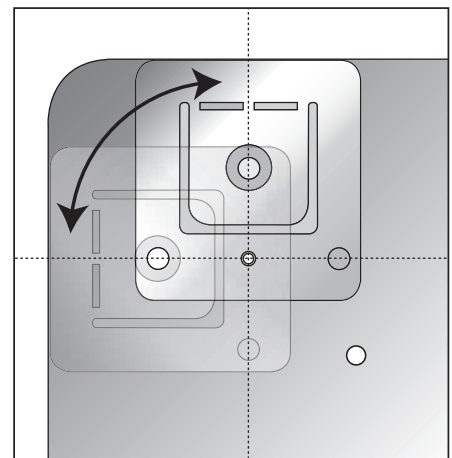
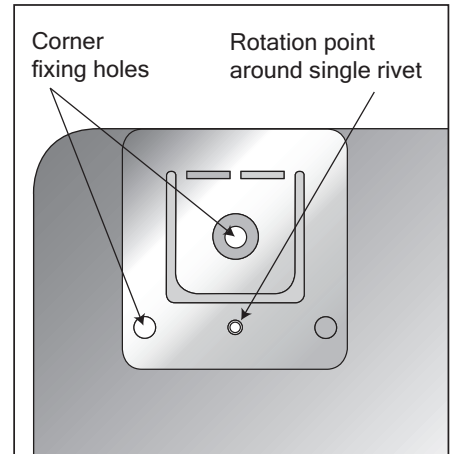
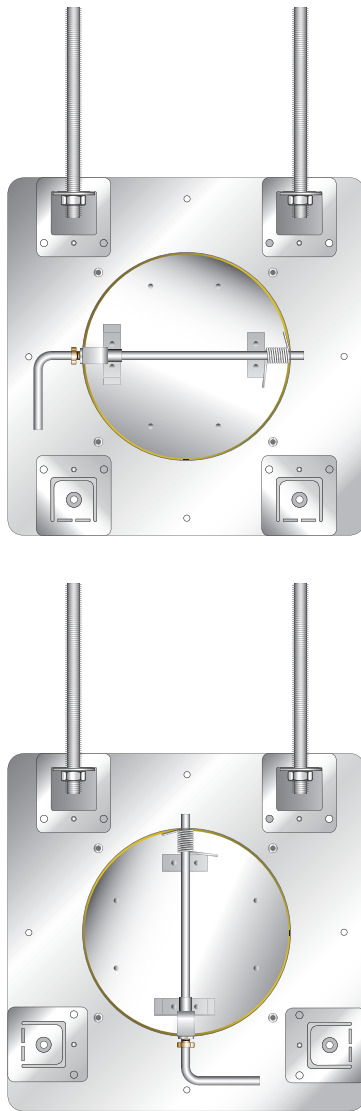
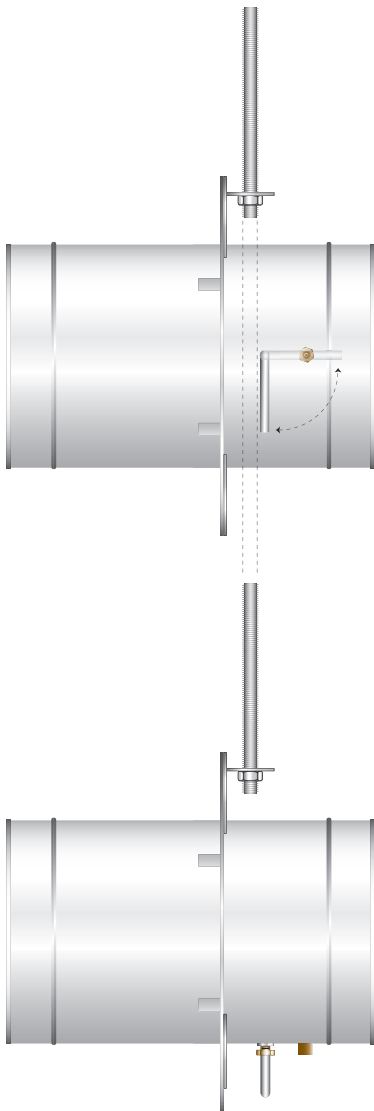

### Folded Installation Plate

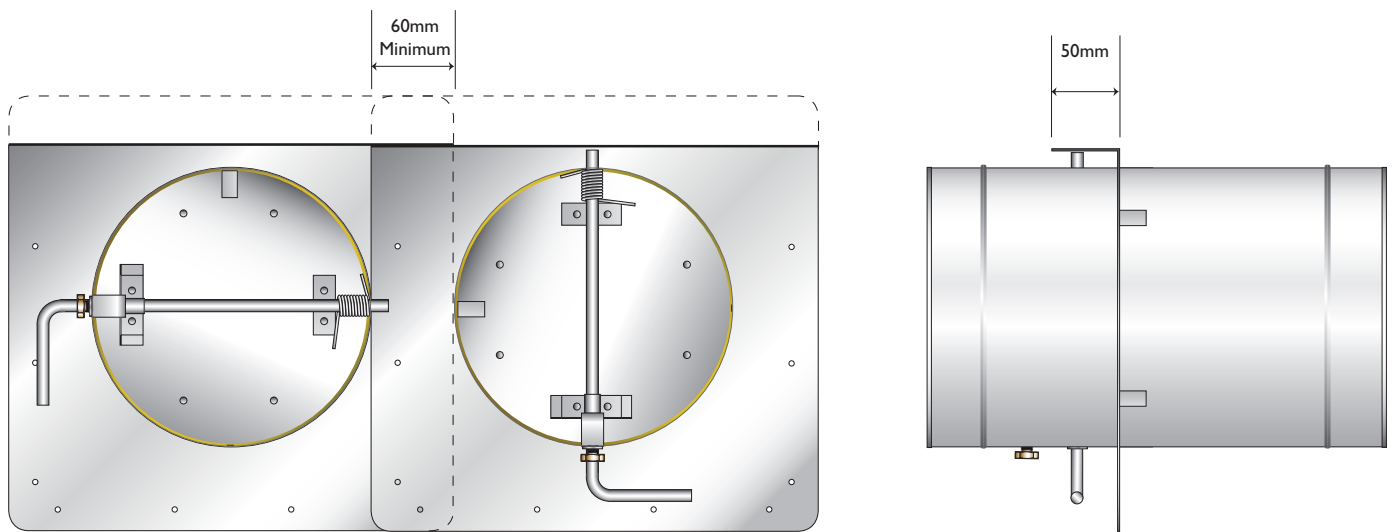

The top installation plate can be folded forward and the side adjacent installation plates, overlapping to allow dampers to be installed close together.

#### Benefits

- Suitable for ducting close to a ceiling or underside of a floor.
- Minimal separation gap between adjacent dampers(s) and walls.
- Vertical or horizontal blade orientation
- No additional construction/support design required.

### Cut Installation Plate

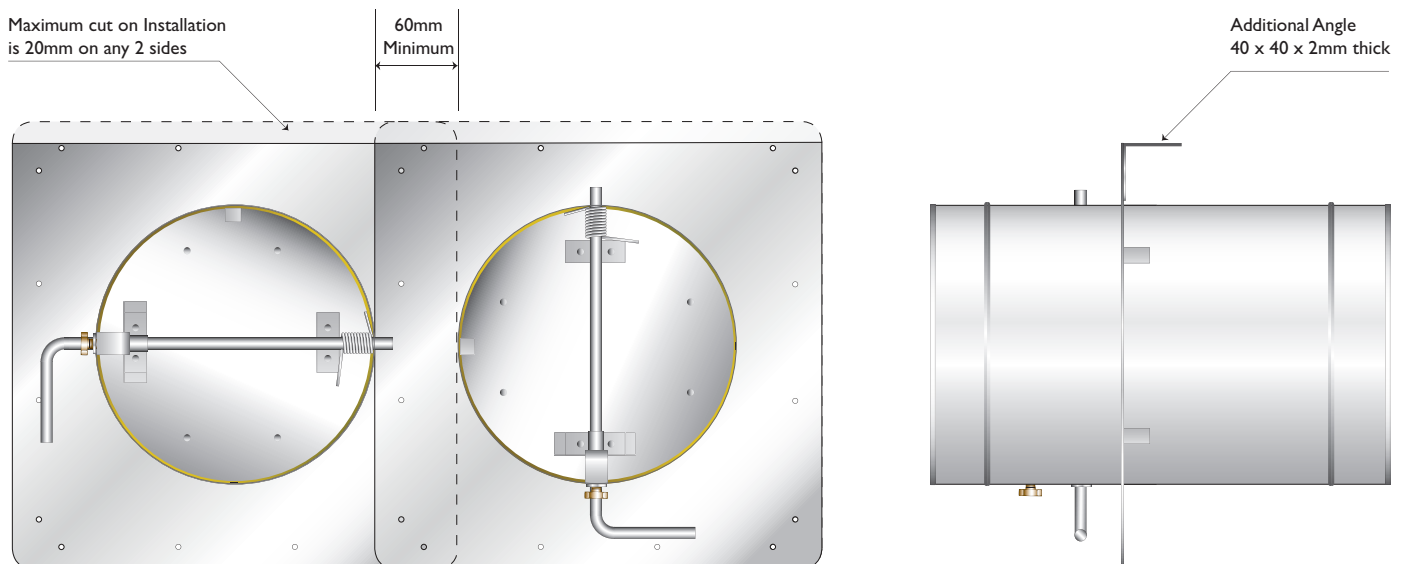

The top of the installation plate and one side can be trimmed down by 20mm. The top of the installation plate will be fixed to a mild steel angle, with the three sides affixed as detailed in the installation drawings.

#### Benefits

- Suitable for ducting close to a ceiling, wall or underside of a floor.
- Minimal separation gap between adjacent dampers(s) and walls.
- Vertical or horizontal blade orientation
- No additional construction/support design required.



# FD-C Series

## Single Blade Circular Fire Dampers - Performance Data



### Performance Data

#### Pressure Drop Graph

100mm diameter. Free area = 64%  
Velocity range 0 to 10 m/s

- 67.5° from open
- 45° from open
- 22.5° from open
- Fully open

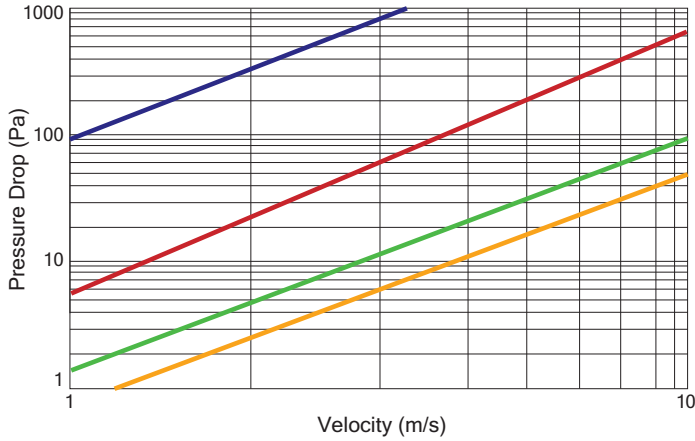

#### Pressure Drop Graph

200mm diameter. Free area = 85%  
Velocity range 0 to 10 m/s

- 67.5° from open
- 45° from open
- 22.5° from open
- Fully open

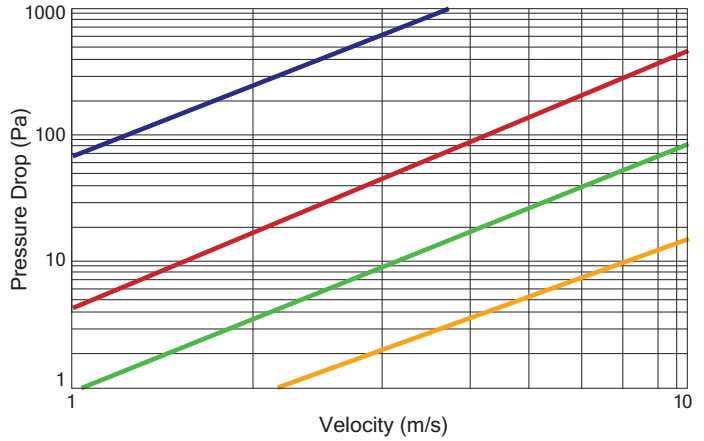

#### Pressure Drop Graph

300mm diameter. Free area = 91%  
Velocity range 0 to 10 m/s

- 67.5° from open
- 45° from open
- 22.5° from open
- Fully open

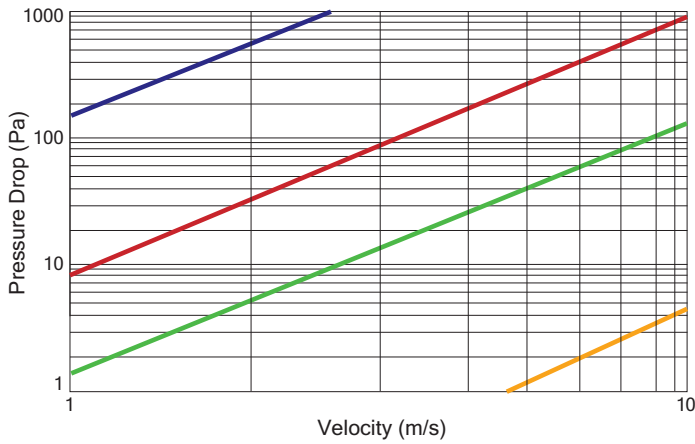

#### Case Leakage Curve

##### Model FD-C100 to BS EN 1751

Shaded area - above 1000Pa for system pressure test only.  
Normal operation maximum 1000Pa

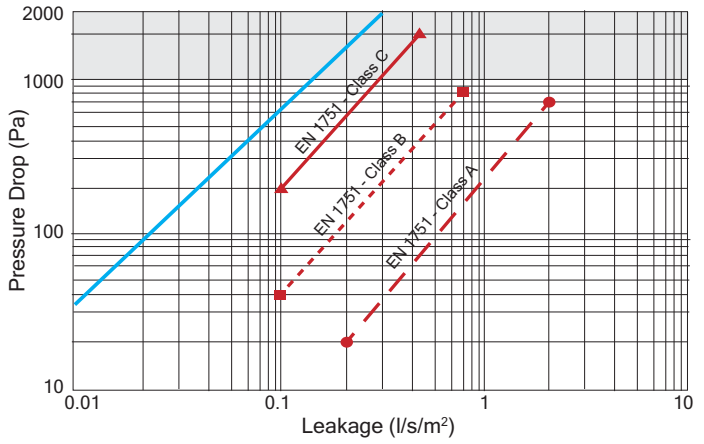

#### Blade Leakage Graph

- 300mm dia.
- 200mm dia.
- 100mm dia.

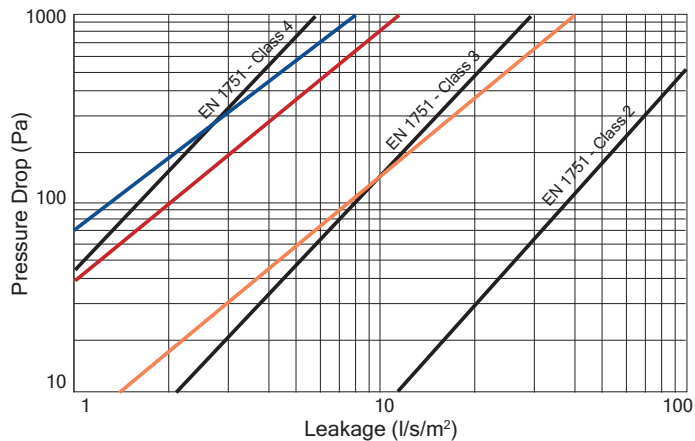

#### Ambient Case Leakage

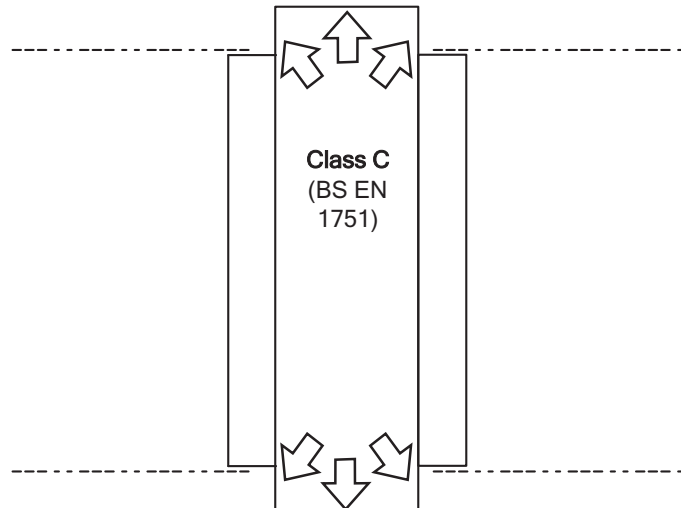

### FD-C in Blockwork Wall

#### Tested to BS EN 1366-2

The FD-C series damper has been tested both ways, with access side inside the furnace and non-furnace side.

#### Test Conclusions:

The FD-C damper satisfied the requirements of BS EN 1366-2 and BS EN 13501-3.

Dampers were tested affixed to the non furnace side of the furnace wall with the damper closed blade being fully exposed to the furnace rapid rising temperature.

The achieved ES classification ensures that in a fire condition the non fire side is fully protected (from radiated heat) for the achieved period, providing vital time for the emergency services to respond, ensuring safe passage of escape and protection of contents.

- Tested to BS EN 1366-2 and classified to BS EN 13501-3
- DW145 Method 4 refers
- ES120 integrity and leakage classification
- Complies with classes A, B & C of DW144 and BS EN 1751
- Fire and Volume Control dual function

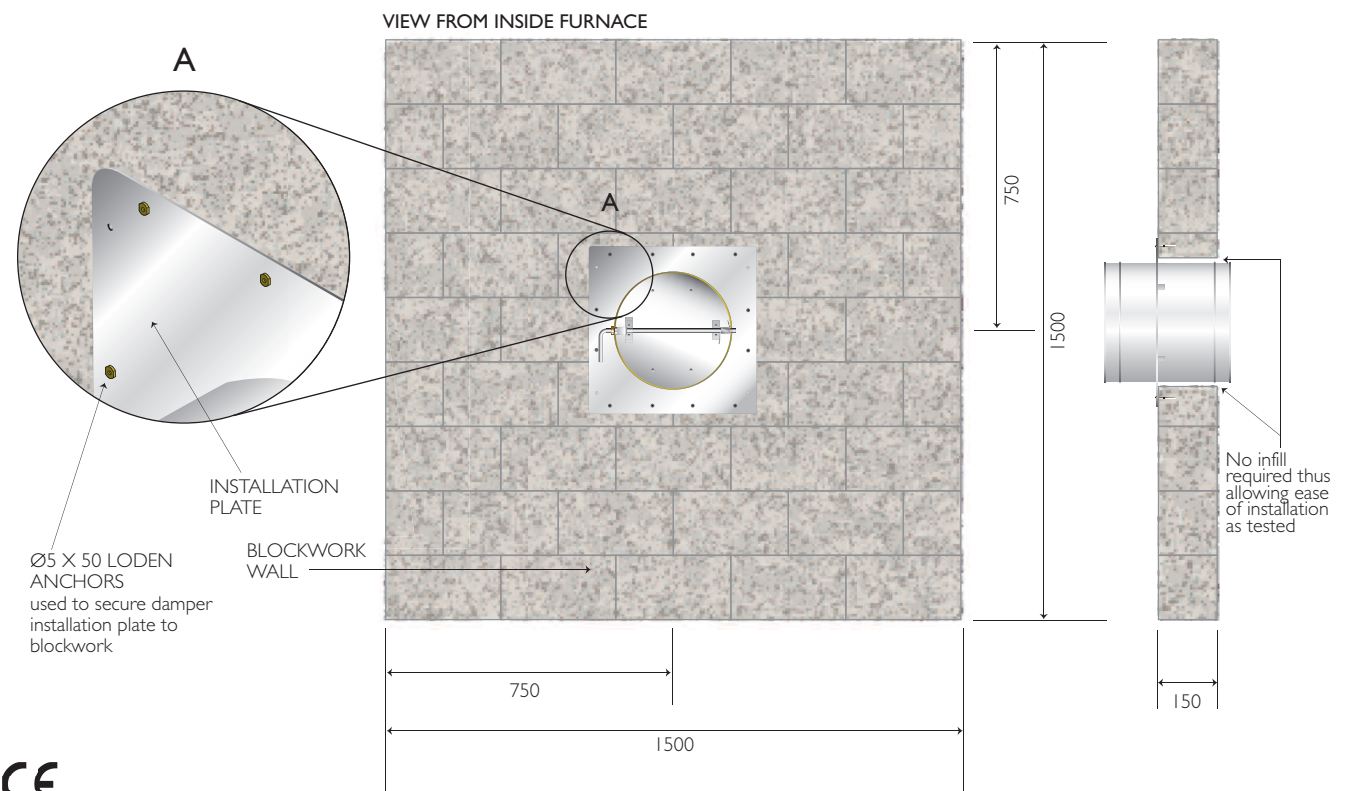
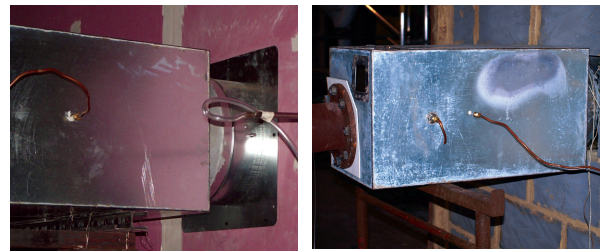

### FD-C in Dry Wall

#### Tested to BS EN 1366-2

The FD-C series damper has been tested both ways, with access side inside the furnace and non-furnace side

#### Test Conclusions:

The FD-C damper satisfied the requirements of BS EN 1366-2 and BS EN 13501-3.

Dampers were tested from both sides of the furnace wall.

The FD-C single blade combination fire and volume control damper with its unique feature of requiring only a single installation plate when being installed within tested applications, and without the need for any infill between the damper body and the structure that it sits within.

- Tested to BS EN 1366-2 and classified to BS EN 13501-3
- ES90 integrity and leakage classification.
- Complies with classes A, B & C of DW144.
- Fire and Volume Control dual function

VIEW FROM NON-FURNACE SIDE

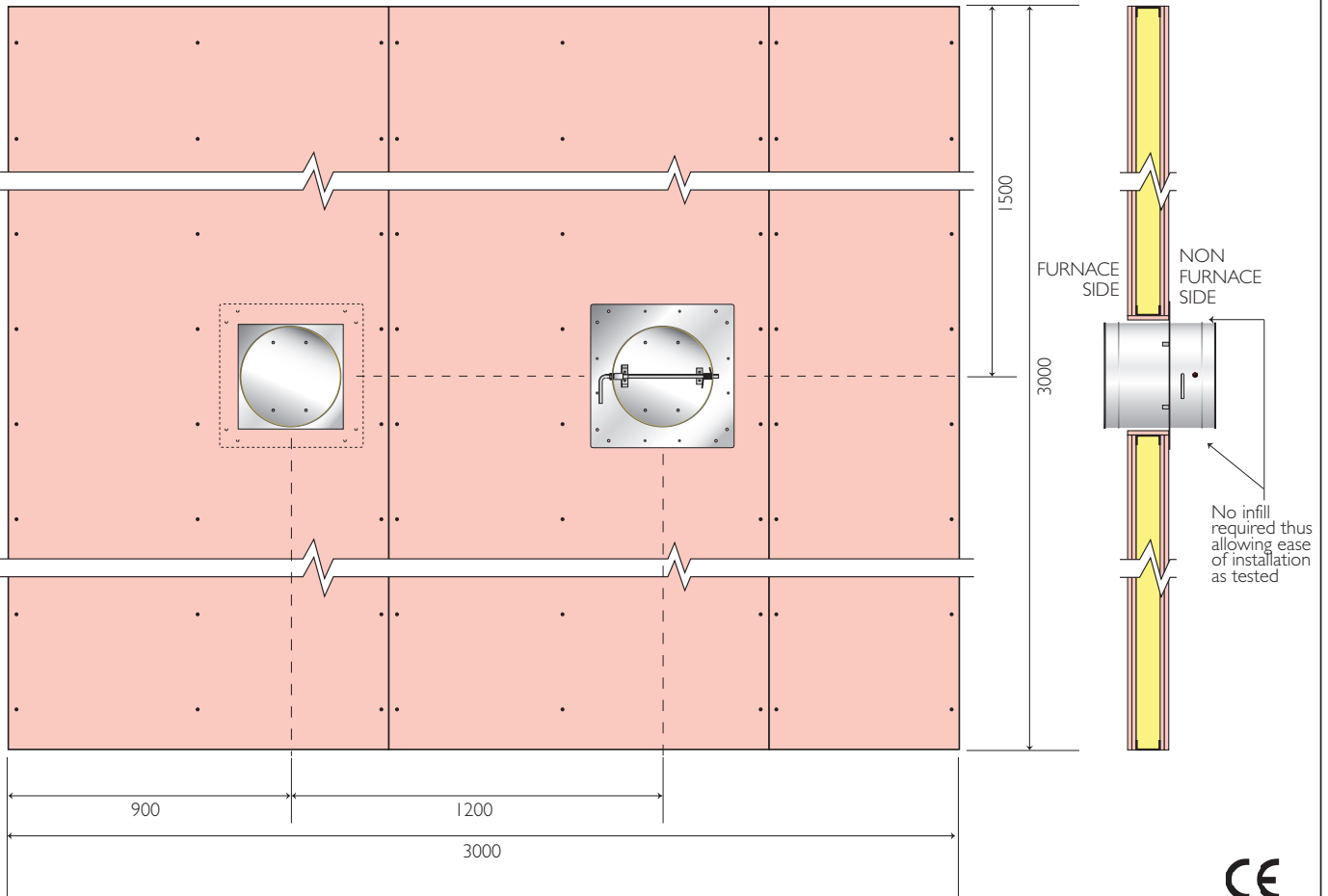



CONNECTING DUCTWORK AND FIREBATT HAVE BEEN OMITTED FOR CLARITY.  
 USE BREAK-AWAY JOINTS (ALUMINIUM RIVETS) ON CONNECTING DUCTWORK.  
 PLEASE REFER TO INSTALLATION, OPERATING AND MAINTENANCE DOCUMENT FOR DETAILED INFORMATION.

**FD-C M8**  
**SHEET 1 OF 3**

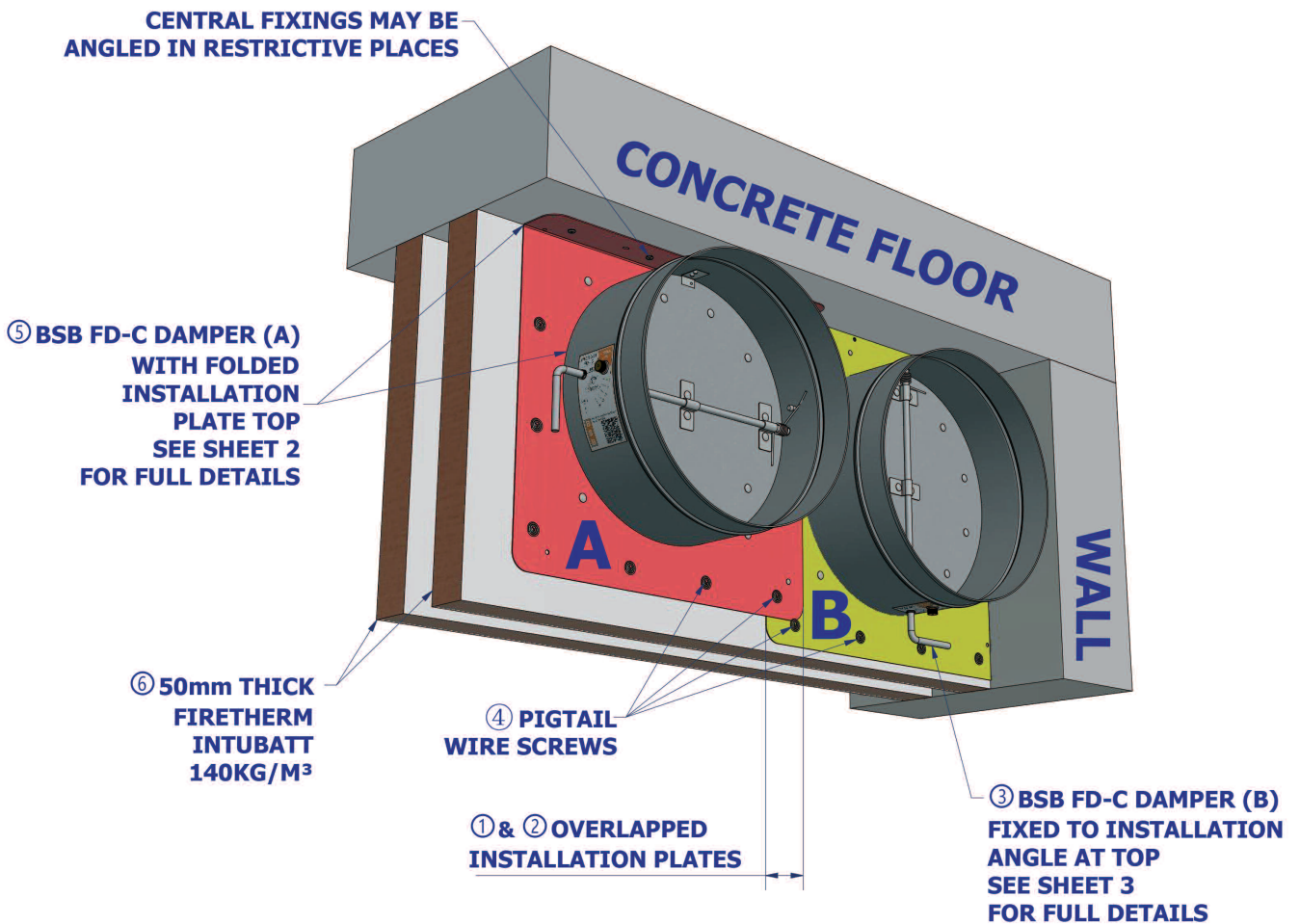

- ① OVERLAPPING INSTALLATION PLATES TO BE DRILLED & FIXED TOGETHER AT 120mm (MAX) CTRS, WITH Ø3.2MM (MIN) STEEL FIXINGS
- ② INSTALLATION PLATES OF MULTIPLE DAMPERS ARE ALLOWED TO OVERLAP (0-60MM)
- ③ DAMPER MAY BE INSTALLED WITH THE HANDLE ON THE BOTTOM
- ④ INSTALLATION PLATE FIXED TO FIREBATT WITH INTUMESCENT MASTIC AND PIGTAIL WIRE SCREWS (ALL REQUIRED FIXING HOLES MUST HAVE FIXINGS)
- ⑤ 50MM (MAX.) FOLD APPLIED TO TOP OF INSTALLATION PLATE FOR FIXING TO MASONRY CEILING
- ⑥ HOLES PRE-CUT IN FIREBATT TO SUIT DAMPER DIAMETER, BEFORE FITMENT OF FIREBATT

**FIREBATT UNSUPPORTED BY FRAMEWORK - 1200MM X 1200MM (MAX)**  
**FIREBATT SEALED WITH INTUMESCENT MASTIC AROUND ALL SEAMS, EDGES AND DAMPERS**  
**FIREBATT'S SEAMS STAGGERED BETWEEN SKINS**

2 OFF FD-C DAMPERS TESTED WITH COMMON AND SPECIFIC SITE NUANCES, I.E. 1/ REDUCED INSTALLATION PLATE WIDTH/HEIGHT. 2/ FOLDED (TOP) INSTALLATION PLATE. 3/ OVERLAPPING INSTALLATION PLATES. 4/ VERTICAL BLADE-AXIS INSTALLATIONS. 5/ INSTALLATION INTO CORNERS OF CAVITIES. DIFFERING INSTALLATIONS WILL REQUIRE THE BCA TO REFER TO THIS DOCUMENT AND ASSOCIATED FIRE TESTS/DOCUMENTS CONTAINED HEREIN, IN ORDER TO CONSIDER APPROVAL.

<b>ABLATIVE BATT PENETRATION SEAL</b>	<b>120 MINUTES FIRE RESISTANCE</b> <b>E 120 (ve i → o) S</b>
BSB FD-C OVERLAPPING / MODIFIED INSTALLATION PLATE	
Sizes(mm) Ø100mm to Ø315mm	BS EN1366-2 TEST REFERENCE 107602-1004 <a href="http://www.bsb-dampers.co.uk">www.bsb-dampers.co.uk</a>

CONNECTING DUCTWORK AND FIREBATT HAVE BEEN LARGELY OMITTED FOR CLARITY. USE BREAK-AWAY JOINTS (ALUMINIUM RIVETS) ON CONNECTING DUCTWORK. PLEASE REFER TO INSTALLATION, OPERATING AND MAINTENANCE DOCUMENT FOR DETAILED INFORMATION.

FD-C M8

SHEET 2 OF 3

## DAMPER A

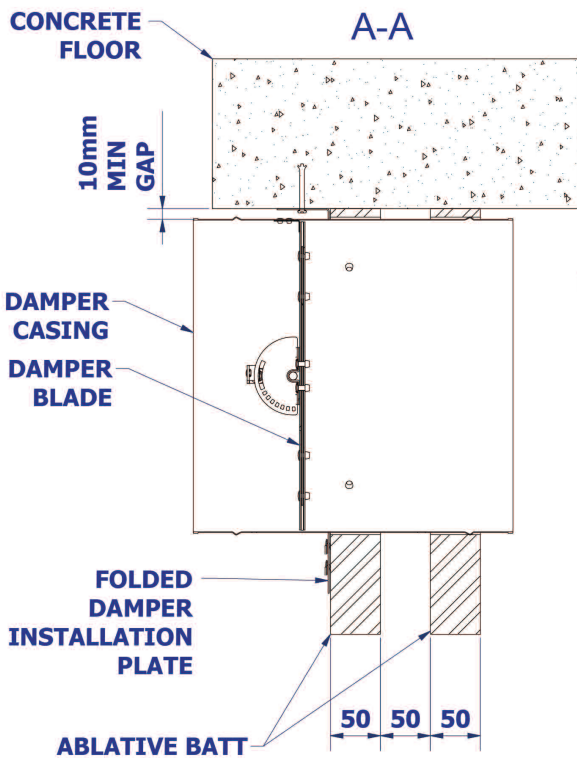
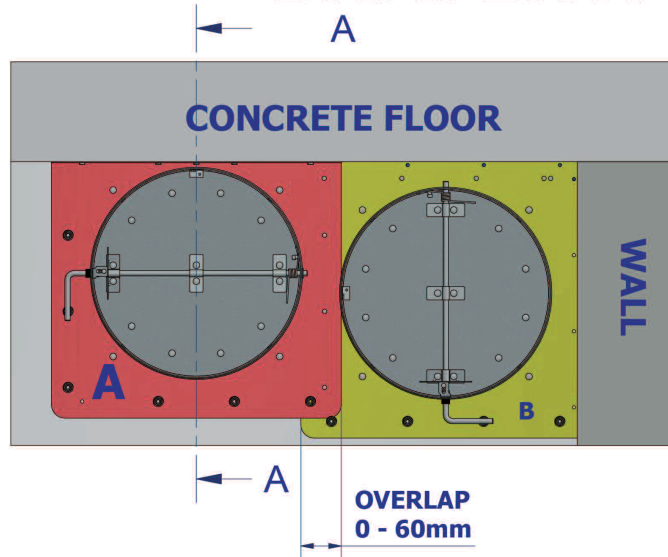

Ø5 X40mm (MIN.) STEEL MASONRY FIXINGS. CENTRAL FIXINGS NEED TO BE ANGLED

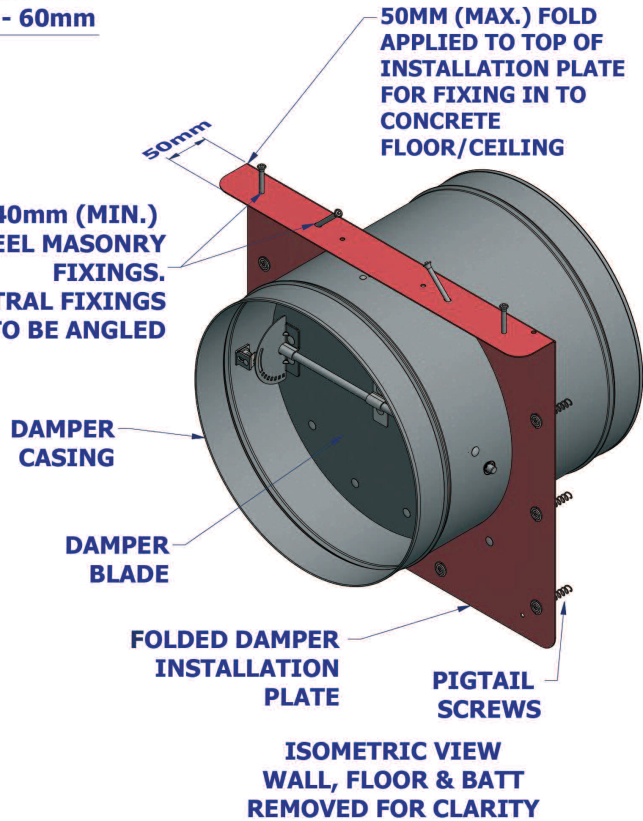

2 OFF FD-C DAMPERS TESTED WITH COMMON AND SPECIFIC SITE NUANCES, I.E. 1/ REDUCED INSTALLATION PLATE WIDTH/HEIGHT. 2/ FOLDED (TOP) INSTALLATION PLATE. 3/ OVERLAPPING INSTALLATION PLATES. 4/ VERTICAL BLADE-AXIS INSTALLATIONS. 5/ INSTALLATION INTO CORNERS OF CAVITIES. DIFFERING INSTALLATIONS WILL REQUIRE THE BCA TO REFER TO THIS DOCUMENT AND ASSOCIATED FIRE TESTS/DOCUMENTS CONTAINED HEREIN, IN ORDER TO CONSIDER APPROVAL.

### ABLATIVE BATT PENETRATION SEAL

BSB FD-C  
OVERLAPPING / MODIFIED INSTALLATION PLATE

Sizes(mm)  
Ø100mm to Ø315mm



**120 MINUTES FIRE RESISTANCE**  
**E 120 (ve i → o) S**

BS EN1366-2 TEST REFERENCE 107602-1004

[www.bsb-dampers.co.uk](http://www.bsb-dampers.co.uk)



CONNECTING DUCTWORK HAS BEEN OMITTED FOR CLAITY. USE BREAK-AWAY JOINTS (ALUMINIUM RIVETS). PLEASE REFER TO INSTALLATION, OPERATING AND MAINTENANCE DOCUMENT FOR DETAILED INFORMATION.

## DAMPER B

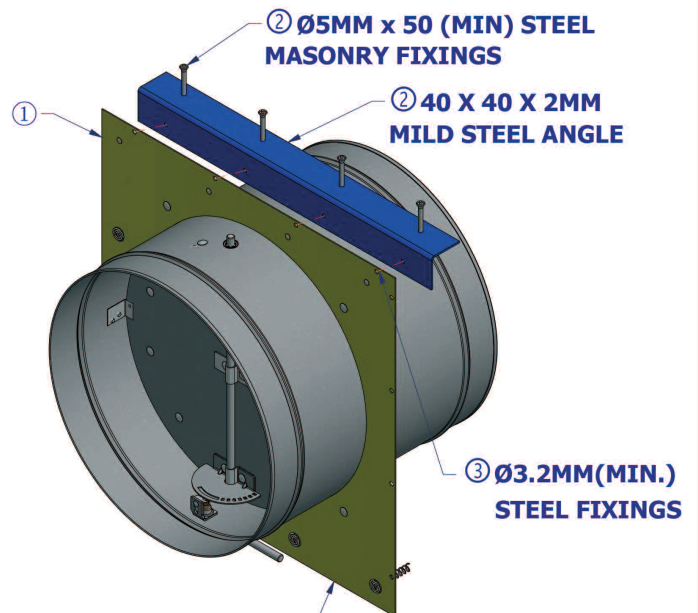
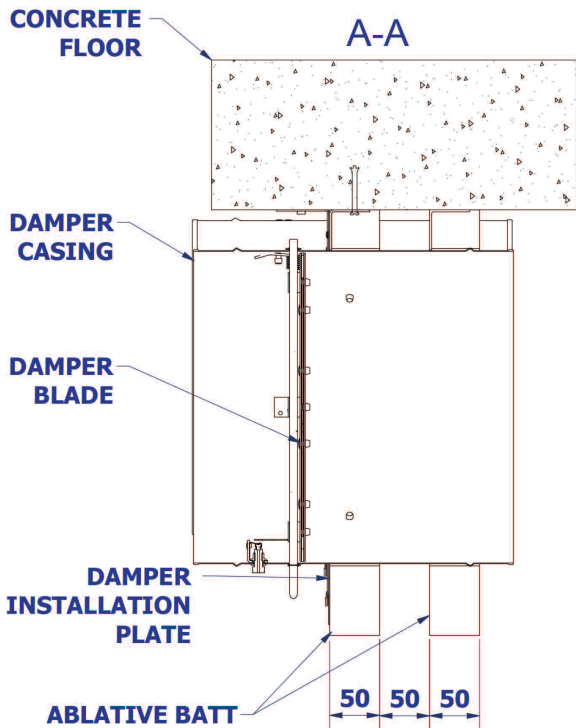
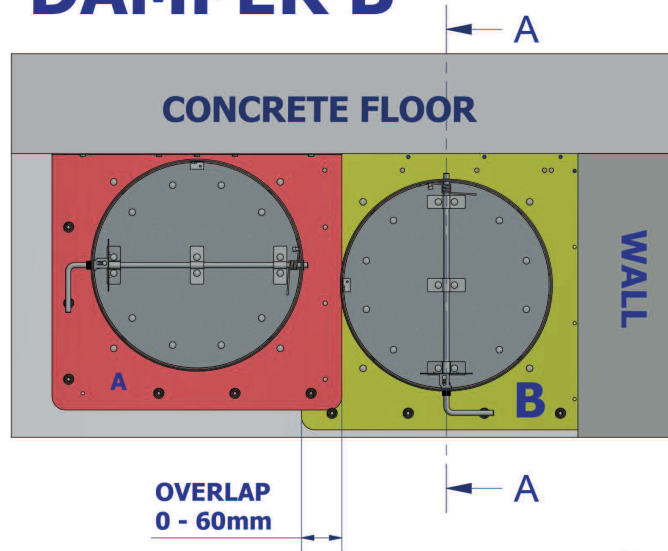

BSB FD-C DAMPER (B) WITH REDUCED TOP AND WALL SIDE ON INSTALLATION PLATE

ISOMETRIC VIEW WALL, FLOOR & BATT REMOVED FOR CLARITY

- ① INSTALLATION PLATE MAY BE TRIMMED DOWN TO 40MM AT THE TOP AND SIDE
- ② ANGLE FIXED TO MASONRY USING Ø5 x 50MM DIA STEEL MASONRY FIXINGS
- ③ INSTALLATION PLATE FIXED TO ANGLE USING 3.2MM DIA FIXINGS

2 OFF FD-C DAMPERS TESTED WITH COMMON AND SPECIFIC SITE NUANCES, I.E. 1/ REDUCED INSTALLATION PLATE WIDTH/HEIGHT. 2/ FOLDED (TOP) INSTALLATION PLATE. 3/ OVERLAPPING INSTALLATION PLATES. 4/ VERTICAL BLADE-AXIS INSTALLATIONS. 5/ INSTALLATION INTO CORNERS OF CAVITIES. DIFFERING INSTALLATIONS WILL REQUIRE THE BCA TO REFER TO THIS DOCUMENT AND ASSOCIATED FIRE TESTS/DOCUMENTS CONTAINED HEREIN, IN ORDER TO CONSIDER APPROVAL.

### ABLATIVE BATT PENETRATION SEAL

BSB FD-C  
OVERLAPPING / MODIFIED INSTALLATION PLATE

Sizes(mm)  
Ø100mm to Ø315mm

**CE** 120 MINUTES FIRE RESISTANCE  
**E 120 (ve i → o) S**

BS EN1366-2 TEST REFERENCE 107602-1004

[www.bsb-dampers.co.uk](http://www.bsb-dampers.co.uk)



# FD-C Series

## Single Blade Circular Fire Dampers - Ordering Codes



FD-C 200 G MS

**FD-C** Externally Resettable Circular Single Blade Damper

Diameter: \_\_\_\_\_

Blade Material \_\_\_\_\_

- G** Galvanised Mild Steel
- S** 430 Grade Stainless Steel

Accessories \_\_\_\_\_

- MS** Single Pole Micro Switch
- R-CL** Rotatable Cleat

### Other Air, Fire and Smoke Control Products in the BSB Range:



For full details of the complete BSB Product Range, please refer to our individual product brochures, sales office or website.



### BSB Engineering Services Limited

Unit 56, Trinity Trade Centre, Mill Way, Sittingbourne, Kent ME10 2PD, UK • Tel: +44 (0)1795 422609

For purchase orders and order related enquiries, please email: [orders@bsb-dampers.co.uk](mailto:orders@bsb-dampers.co.uk)

For pricing, technical and general enquiries, please email: [enquiries@bsb-dampers.co.uk](mailto:enquiries@bsb-dampers.co.uk)

Website: [www.bsb-dampers.co.uk](http://www.bsb-dampers.co.uk) • A member of the Maico group

BSB Engineering Services Ltd. reserves the right to modify or withdraw any specification without prior notice that may result from continuous product development. The information contained within this brochure is correct at the time of going to press. (FDC-11-2020)

