

RVK 200E2 sileo 1ph/230V

Article Number: 36092

Variant : 230V 1~ 50Hz



Description

- Speed-controllable
- Integral thermal contacts acc. EN 60335-2-80
- Can be installed in any position
- Inclusive mounting bracket
- Maintenance-free and reliable

The RVK sileo series is designed for installation in ducts. The casing is manufactured from PP fibreglass reinforced plastic which gives the fan a less leakage casing. Duct connected wet room applications of the fan are possible due to the air tight casing and the IP 44 rated terminal box. We recommend a period of continued ventilation with dry air for wet room applications. The fans have high effective backward-curve blades (* BAT with special geometry) and external rotor motors. The FK mounting clamp facilitates easy

[Find more details in our online catalogue](#)

Technical parameters

Nominal data	
Voltage (Nominal)	230 V
Frequency	50 Hz
Phase(s)	1~
Input power	104 W
Input current	0.46 A
Impeller speed	2,495 r.p.m.
Air flow	max 0.221 m³/s
Capacitance of capacitor	3 µF
Temperature of transported air	max 70 °C
Max temperature of transported air, when speed controlled	70 °C
Sound data	
Sound pressure level at 3m (20m² Sabin)	42 dB(A)
Protection/Classification	
Enclosure class, motor	IP44
Insulation class	F
Data according to ErP	
Energy class, Basic unit	E
Energy class, Local demand	B
ErP ready	ErP 2016; ErP 2018
Dimensions and weights	
Duct dimension: Circular, inlet	200 mm
Duct dimension: Circular, outlet	200 mm
Weight	3.3 kg
Others	
Duct connection type	Circular
Motor type	AC

Dimension

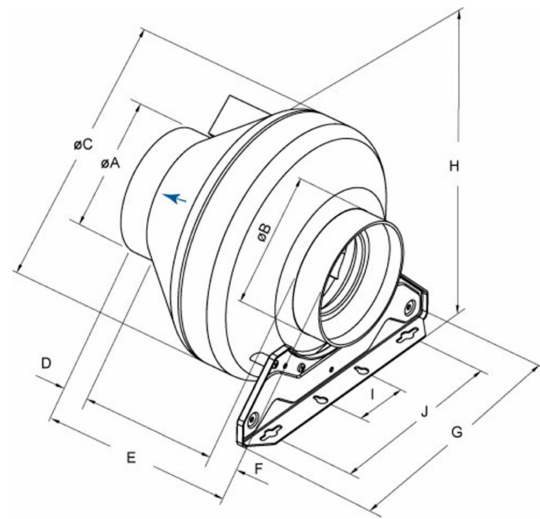

	øA	øB	øC	D	E	F	G	H	I	J
RVK 200	19	19	34	3	22	3	27	36	6	200
200	9	9	1	0	9	0	2	0	0	

Wiring

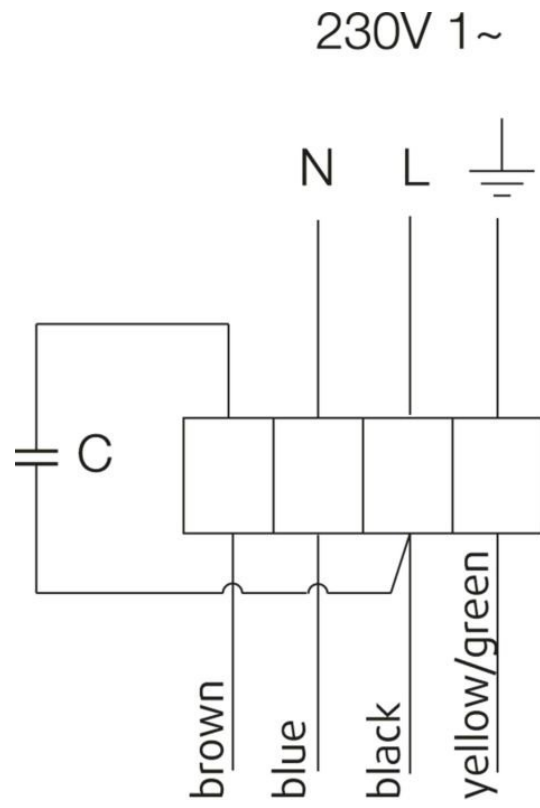

Performance curve

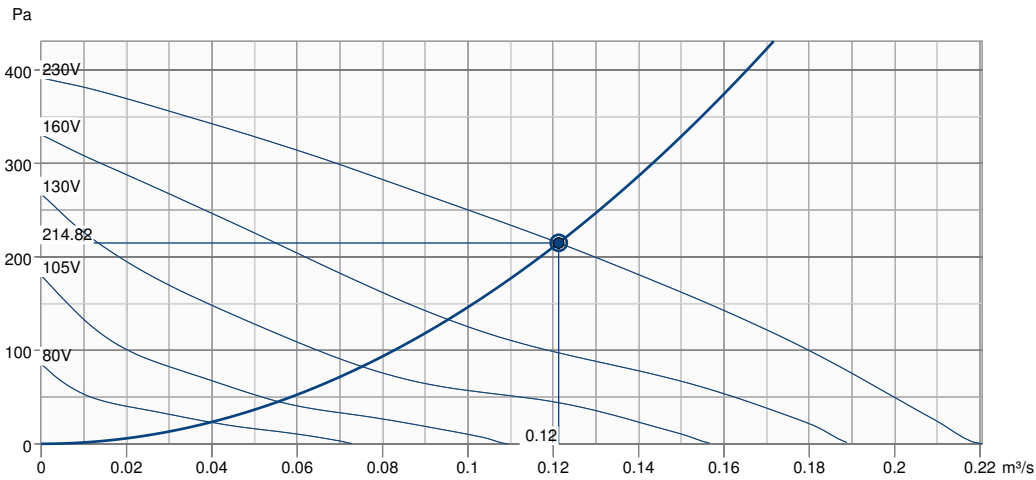

Hydraulic data

Required air flow	0.12 m³/s
Required static pressure	215 Pa
Working air flow	0.12 m³/s
Working static pressure	215 Pa
Air density	1.204 kg/m³
Power	104.5 W
Fan control - RPM	2497 rpm
Current	0.46 A
SFP	0.862 kW/m³/s
Control voltage	230.0 V
Supply voltage	230 V

Sound power level		63	125	250	500	1k	2k	4k	8k	Total
Inlet	dB(A)	41	58	60	62	61	61	56	47	68
Outlet	dB(A)	47	56	54	61	58	59	56	50	66
Surrounding	dB(A)	20	27	31	44	43	43	37	27	49
Sound pressure level at 3m (20m² Sabine)	dB(A)	-	-	-	-	-	-	-	-	42
Sound pressure level at 3m free field	dB(A)	-	-	-	-	-	-	-	-	28

Accessories

FRQ5S-E-6A (37421)	RE 1,5 Speed control (5000)
REE 1 Speed control (5314)	REU 1.5 Speed control (5004)
REV-3POL/03 ON/OFF (33978)	SG 200 Protection guard (5609)
VKK-200 Back draft damper (1626)	FRQS-E-6A (37419)
IGK-200 Wall Grid (1633)	VBFB 200 Water heating battery (1732)
CB 200-2,1 230V/1 Duct heater (5384)	CB 200-3,0 230V/1 Duct heater (5370)
CB 200-3,0 400V/2 Duct heater (5294)	CB 200-5,0 400V/2 Duct heater (5371)
CBM 200-5,0 400V/2 Duct heater (5483)	CWK 200-3-2,5 Duct cooler,circ (30023)
FFR 200 Filter cassette (1773)	FGR 200 Filter cassette (1812)
FK 200 Fast clamp (1611)	LDC 200-600 Silencer (5194)
LDC 200-900 Silencer (5195)	RSK-200 Back draft damper (5602)
VBC 200-2 Water heating batt (5459)	VBC 200-3 Water heating batt (9841)
VK-20 Louvre shutter (5639)	IGC-200 Intake grille (76877)
STL 1.5 Speed controller (84251)	

Documents

MANUAL_RVK_EN_002.PDF
rvk200_kpl.dxf
EU DECLARATION OF CONFORMITY_RVK_EN_001.PDF
PP compound (30% glass fibre content).pdf