

## DHS Roof Fans

### Centrifugal roof fan with horizontal discharge

- Available with AC motors for 50 and 60Hz
- Extensive range of accessories

[Find more details in our online catalogue.](#)



#### Flexibility

The DHS fans are intended to use for **extract** air with **horizontal discharge**.

The fans are designed to handle high volumes at medium pressure without generating excessive noise.

#### Reliability

The casing made out of **seawater resistant aluminium** with an inside **galvanised steel frame** is hard-wearing.

The combination of casing and motor construction ensures to minimize the need for maintenance of the fans and allows long **continuous operation**.

#### Performance

**The sound optimized** impellers together with **high efficient** external rotor motors are designed to ensure high-level performance to **minimize power consumption** and **maximize efficiency**.

#### Accessories

DHS fans can be selected together with variety types of **accessories** as roof sockets, tilting devices, dampers, etc.

## Certifications



Ecodesign (ErP) compliant

## Features

### Construction

The **Casing** is made from **sea water resistant aluminium**. **Base frame** manufactured from **galvanised steel** with integrated inlet cone. Integrated bird guard manufactured from powder coated, galvanised steel or sea water resistant aluminium.

### Impeller

The DHS fans use **radial** impeller with **backward curved blades**. These are made out of high-performance composite material or aluminum, dynamically **balanced** and paired with corresponding **external rotor** motors.

### Motor

DHS fans are delivered with **AC motors**. Motors are suitable for **50Hz** and **60Hz**.

### Motor protection

Depending on the type, **AC** motors have an **integrated** thermal protection with manual (electrical) reset, prewired integral **thermocontact TK** or **thermistor PTC** with leads to a **motor protection device**.

### Control

**AC motors** can be controlled by **5-step, stepless** speed regulator, **D/Y** switch or **frequency converter**.

### Installation

The DHS fans are for **outside installation**.

## Technical parameters

### Nominal data

Voltage (nominal)	400	V
Frequency	50	Hz
Phases	3~	
Motor circuit connection	D; Y	
Input power	812	W
Input power kW	0.812	kW
Input current	1.53	A
Impeller speed	1,365	rpm
Air flow	max 1.6661	m³/s
Temperature of transported air	max 60	°C
Max temperature of transported air, when speed controlled	60	°C

### Protection/Classification

Enclosure class, motor	IP54
Insulation class	F

### Data according to ErP

ErP ready	ErP 2018
-----------	----------

### Dimensions and weights

Weight	34.2	kg
--------	------	----

### Others

Motor type	AC
------------	----

Performance

Performance curve

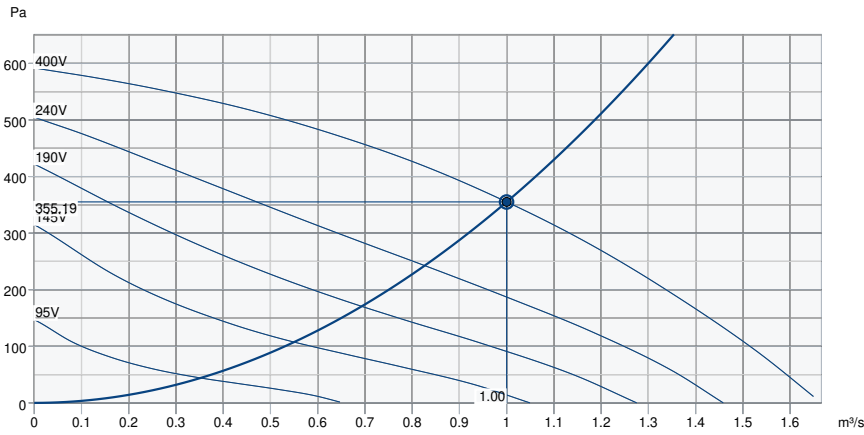

Hydraulic data

Required air flow	1.00 m³/s
Required static pressure	355 Pa
Working air flow	1.00 m³/s
Working static pressure	355 Pa
Air density	1.204 kg/m³
Power	813.0 W
Fan control - RPM	1,365 rpm
Current	1.50 A
SFP	0.813 kW/m³/s
Control voltage	400.0 V
Supply voltage	400 V

Sound power level		63	125	250	500	1k	2k	4k	8k	Total
Inlet	dB(A)	41	56	65	68	68	63	58	51	73
Outlet	dB(A)	43	58	67	70	69	64	59	53	74

## Ecodesign

Product	
Trade name	Systemair
Product name	DHS 450DV
Ecodesign	
ErP compliance	2018
Unit category	NRVU
Drive	External MSD or VSD
Unit type	UVU
Heat recovery type	None
Temperature ratio (UVU)	Not applicable
qv nom	1 m <sup>3</sup> /s
P nom	0.813 kW
Ps nom	355 Pa
Fan efficiency	43.7 %
External Leakage	0 %
Sound power (LWA)	74 dB(A)

## Dimension

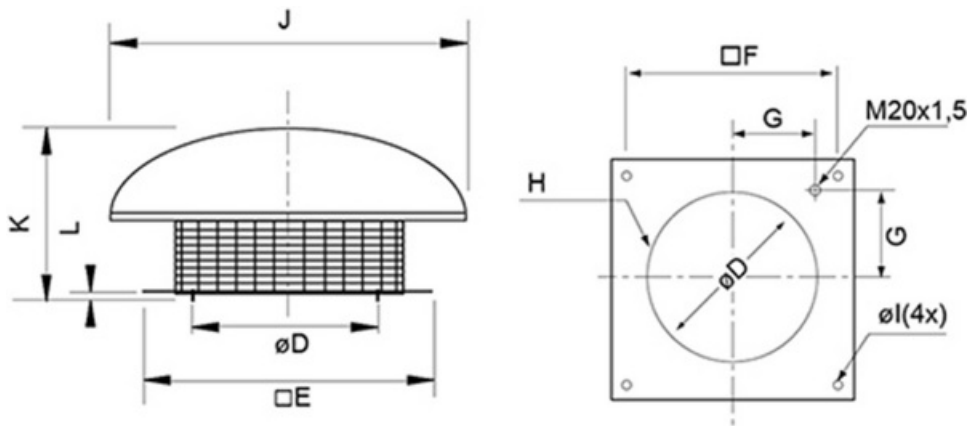

\* diameter D refers to scREW-hole-circuit H

DHS/DHS sileo	øD	□E	□F	G	H	øl	J	K	L
450-500	438	665	535	237	6xM8	12	ø830	490	30

Wiring

Delta connection

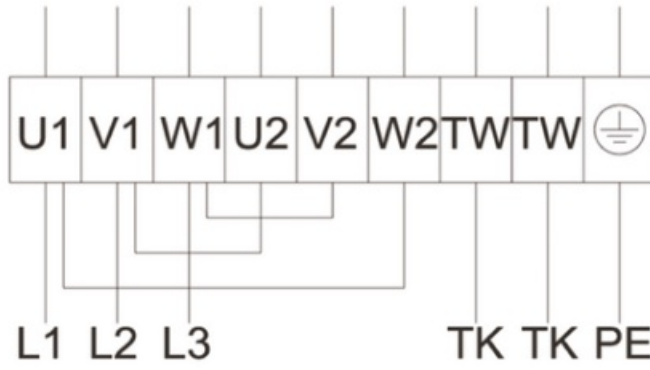

Star connection

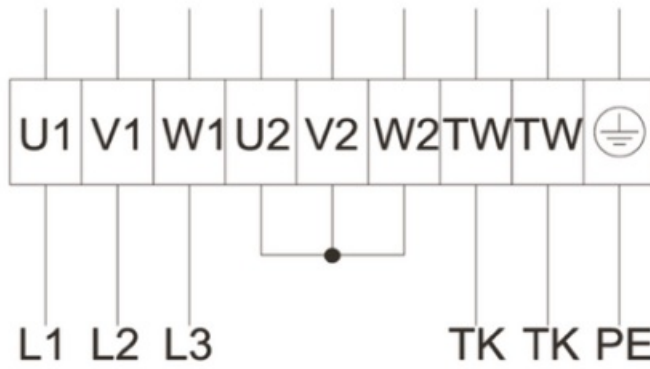

## Accessories

- ASF 355-500 inlet flange DVS (9569)
- ASS 355-500 flex. con. DVS (9576)
- Frequency converter FRQS-4A (36231)
- REV-9POL/12-7,5kW R/Y (33981)
- RTRDU 2 Speed contr. Systemair (5945)
- Step switch S-DT2SKT, Y/D (2697)
- SDS 450-500 slant. roof socket (3786)
- FDS 450/500 flat roof socket (9551)
- FTG 450/499/500 Tilting device (30248)
- VKS 355-500 Back draft damper (9544)
- ASK 450/500 inflow box SSD (300907)
- Frequency converter FRQ5S-4A (36233)
- REV-5POL/07-7,5kW R/Y (33980)
- RTRD 2 Speed Cont. Systemair (5941)
- SSD 450-500 socket silencer (9563)
- TDA DV 450-500 Adapter (301394)
- SSS 450 slant. socket silencer (30078)
- FDS-L 450/500 flat roof socket (95282)
- SSD 450/500 ZM socket sil (95060)

## Documents

- MANUAL\_ROOF\_FANS\_EN\_002\_.PDF
- UKCA DECLARATION OF CONFORMITY\_ROOF FANS\_EN\_002.PDF