

DHS Roof Fans

Centrifugal roof fan with horizontal discharge

- Available with AC motors for 50 and 60Hz
- Extensive range of accessories

[Find more details in our online catalogue.](#)



Flexibility

The DHS fans are intended to use for **extract** air with **horizontal discharge**.

The fans are designed to handle high volumes at medium pressure without generating excessive noise.

Reliability

The casing made out of **seawater resistant aluminium** with an inside **galvanised steel frame** is hard-wearing.

The combination of casing and motor construction ensures to minimize the need for maintenance of the fans and allows long **continuous operation**.

Performance

The sound optimized impellers together with **high efficient** external rotor motors are designed to ensure high-level performance to **minimize power consumption** and **maximize efficiency**.

Accessories

DHS fans can be selected together with variety types of **accessories** as roof sockets, tilting devices, dampers, etc.

Certifications



Ecodesign (ErP) compliant

Features

Construction

The **Casing** is made from **sea water resistant aluminium**. **Base frame** manufactured from **galvanised steel** with integrated inlet cone. Integrated bird guard manufactured from powder coated, galvanised steel or sea water resistant aluminium.

Impeller

The DHS fans use **radial** impeller with **backward curved blades**. These are made out of high-performance composite material or aluminum, dynamically **balanced** and paired with corresponding **external rotor** motors.

Motor

DHS fans are delivered with **AC motors**. Motors are suitable for **50Hz** and **60Hz**.

Motor protection

Depending on the type, **AC** motors have an **integrated** thermal protection with manual (electrical) reset, prewired integral **thermocontact TK** or **thermistor PTC** with leads to a **motor protection device**.

Control

AC motors can be controlled by **5-step, stepless** speed regulator, **D/Y** switch or **frequency converter**.

Installation

The DHS fans are for **outside installation**.

Technical parameters

Nominal data

Voltage (nominal)	400	V
Frequency	50	Hz
Phases	3~	
Motor circuit connection	D; Y	
Input power	130	W
Input power kW	0.13	kW
Input current	0.26	A
Impeller speed	780	rpm
Air flow	max 0.7131	m³/s
Temperature of transported air	max 60	°C
Max temperature of transported air, when speed controlled	60	°C

Protection/Classification

Enclosure class, motor	IP54
Insulation class	F

Data according to ErP

ErP ready	ErP 2018
-----------	----------

Dimensions and weights

Weight	22	kg
--------	----	----

Others

Motor type	AC
------------	----

Performance

Performance curve

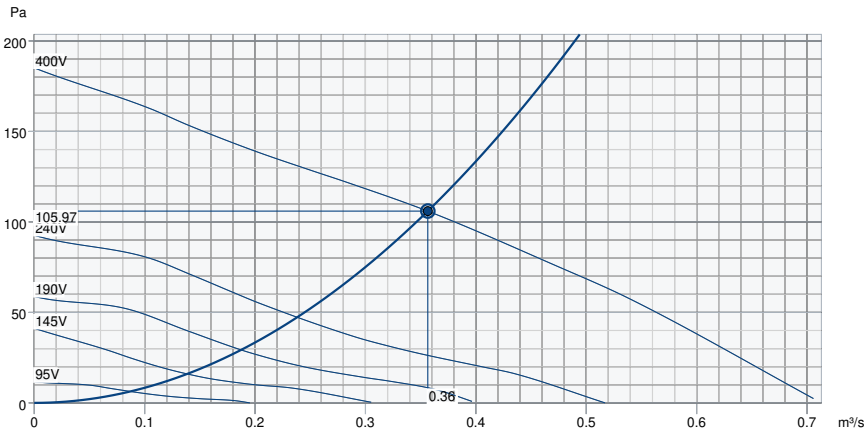

Hydraulic data

Required air flow	0.36 m³/s
Required static pressure	106 Pa
Working air flow	0.36 m³/s
Working static pressure	106 Pa
Air density	1.204 kg/m³
Power	128.3 W
Fan control - RPM	786 rpm
Current	0.30 A
SFP	0.360 kW/m³/s
Supply voltage	400 V

Sound power level		63	125	250	500	1k	2k	4k	8k	Total
Inlet	dB(A)	24	46	57	58	59	53	48	43	63
Outlet	dB(A)	26	48	58	59	61	54	49	45	65

Ecodesign

Product	
Trade name	Systemair
Product name	DHS 400DS sileo roof fan
Ecodesign	
ErP compliance	2018
Unit category	NRVU
Drive	External MSD or VSD
Unit type	UVU
Heat recovery type	None
Temperature ratio (UVU)	Not applicable
qv nom	0.3564 m ³ /s
P nom	0.128 kW
Ps nom	106 Pa
Fan efficiency	29.4 %
External Leakage	0 %
Sound power (LWA)	65 dB(A)

Dimension

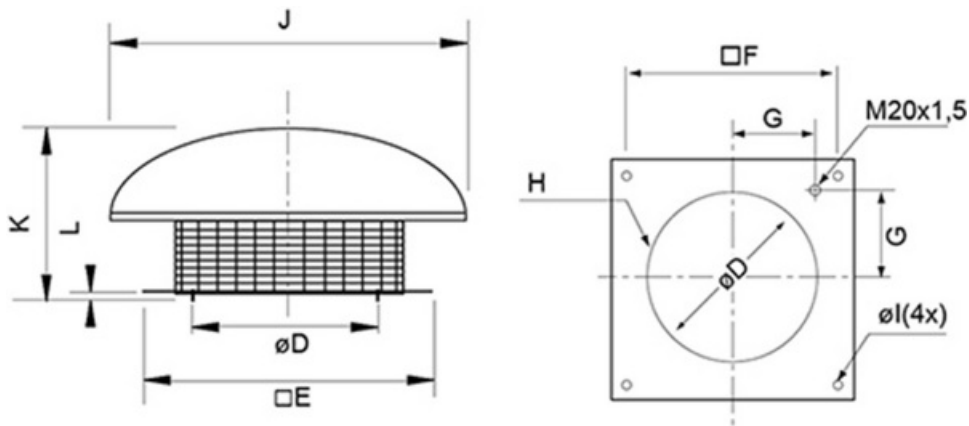

* diameter D refers to scew-hole-circuit H

DHS	øD	□E	□F	G	H	øl	J	K	L
400	438	595	450	200	6xM8	12	ø720	330	30

Wiring

Delta connection

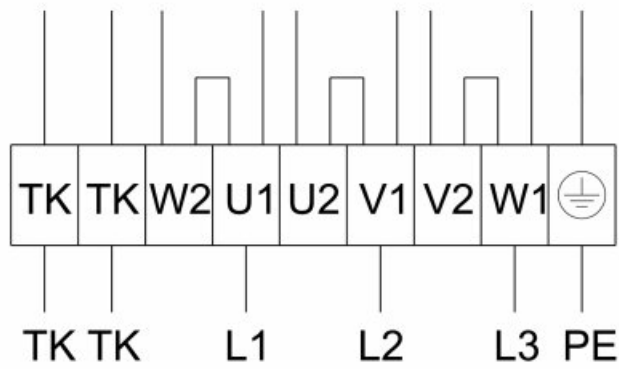

Star connection

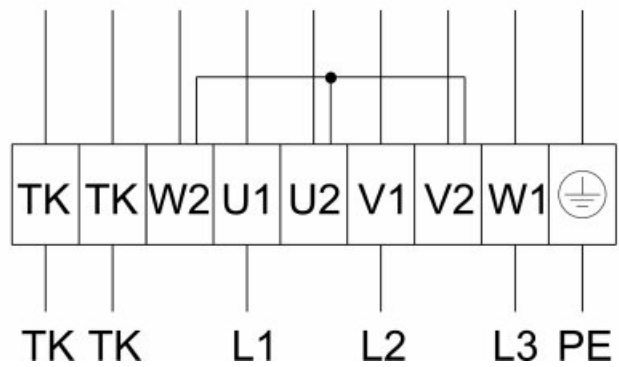

Accessories

- ASF 355-500 inlet flange DVS (9569)
- ASS 355-500 flex. con. DVS (9576)
- Frequency converter FRQS-4A (36231)
- REV-9POL/12-7,5kW R/Y (33981)
- RTRDU 2 Speed contr. Systemair (5945)
- Step switch S-DT2SKT, Y/D (2697)
- SDS 355/400 slant. roof socket (3785)
- FDS 355/400 flat roof socket (9550)
- FTG 355/400 Tilting device (30508)
- VKS 355-500 Back draft damper (9544)
- ASK 355/400 inflow box SSD (300905)
- Frequency converter FRQ5S-4A (36233)
- REV-5POL/07-7,5kW R/Y (33980)
- RTRD 2 Speed Cont. Systemair (5941)
- SSD 355/400 socket silencer (9562)
- TDA DV 355/400 Adapter (301393)
- SSS 355 slant. socket silencer (30077)
- FDS-L 355/400 flat roof socket (95281)
- SSD 355/400 ZM socket sil (95061)

Documents

- MANUAL_ROOF_FANS_EN_002_.PDF
- UKCA DECLARATION OF CONFORMITY_ROOF FANS_EN_002.PDF