

BF Silent 100

Bathroom fan <125W

Item Number: 98617

Variant: 230V 1~ 50Hz

BF SILENT FANS

APPLICATION

Ideal for air-extraction in bathroom, toilet and small/medium premises. Suitable to extract stale air directly to the outside or through short length ducting. Units can be wall/panel, ceiling and window mounted.

SPECIFICATION

Casing made of high quality ABS provides long lasting shock-proof and robust construction. The unit are finished in white RAL 9010 and are UV resistant.

Unique design winglet-type impeller, providing enhanced aerodynamic properties, low noise and increased efficiency. Single-phase induction motors with integral thermal protection, mounted on high quality ball bearings. Suitable for continuous and intermittent running.

FEATURES & BENEFITS

IPX4 protection degree

Aesthetic front flat cover for modern interior design easily removed for cleaning.

Rigid optimised spigot support preventing distortion with strengthened guard and design to maximise airflow.

Integral back-draught shutter to prevent air flowing back into the room when the fan is off.

Low power consumption: 100mm model has less than 8 watts operating power consumption for energy saving.

Totally recyclable plastic components, environmentally friendly. Double insulated: no earth connection is required.

Tested to the latest standards: units are tested in the TÜV Rheinland recognised laboratory, meaning accurate, up to date information on electrical safety, performance and noise level that can be relied upon. Designed and manufactured in accordance with EN60335-2-80 (Low Voltage Directive) and the EMC Directive (Electromagnetic Compatibility).

VERSIONS

Standard

The fan is operated via a separate ON/OFF switch or the light switch.

Run-on timer

The fan is equipped with a timer circuit adjustable from $\pm 1'$ to 25'.

Operation: after switching off, the fan continues to run for the pre-set period of time.

Humidistat & timer

The fan is provided with an electronic circuit having a humidity sensor on board (adjustable from 50% to 95% RH) and a timer, adjustable from $\pm 1'$ to 25'. Operation: when the percentage of relative humidity is higher/lower than the pre-set threshold, the fan is automatically activated/ deactivated. After switching off, the fan continues to run for the pre-set period of time.



Technical parameters

Norminal data

Voltage (Nominal)	230	V
Frequency	50	Hz
Phase(s)	1~	
Input power	8	W
Input current	0.067	A
Impeller speed	2,350	r.p.m.
Air flow	max 0.0231	m³/s
Temperature of transported air	max 50	°C

Sound data

Sound pressure level at 3m (20m² Sabin)	40	dB(A)
---	----	-------

Protection/Classification

Enclosure class, motor	IPX4	
Insulation class	B	

Dimensions and weights

Weight	0.72	kg
--------	------	----

Others

Motor type	AC	
------------	----	--

Performances

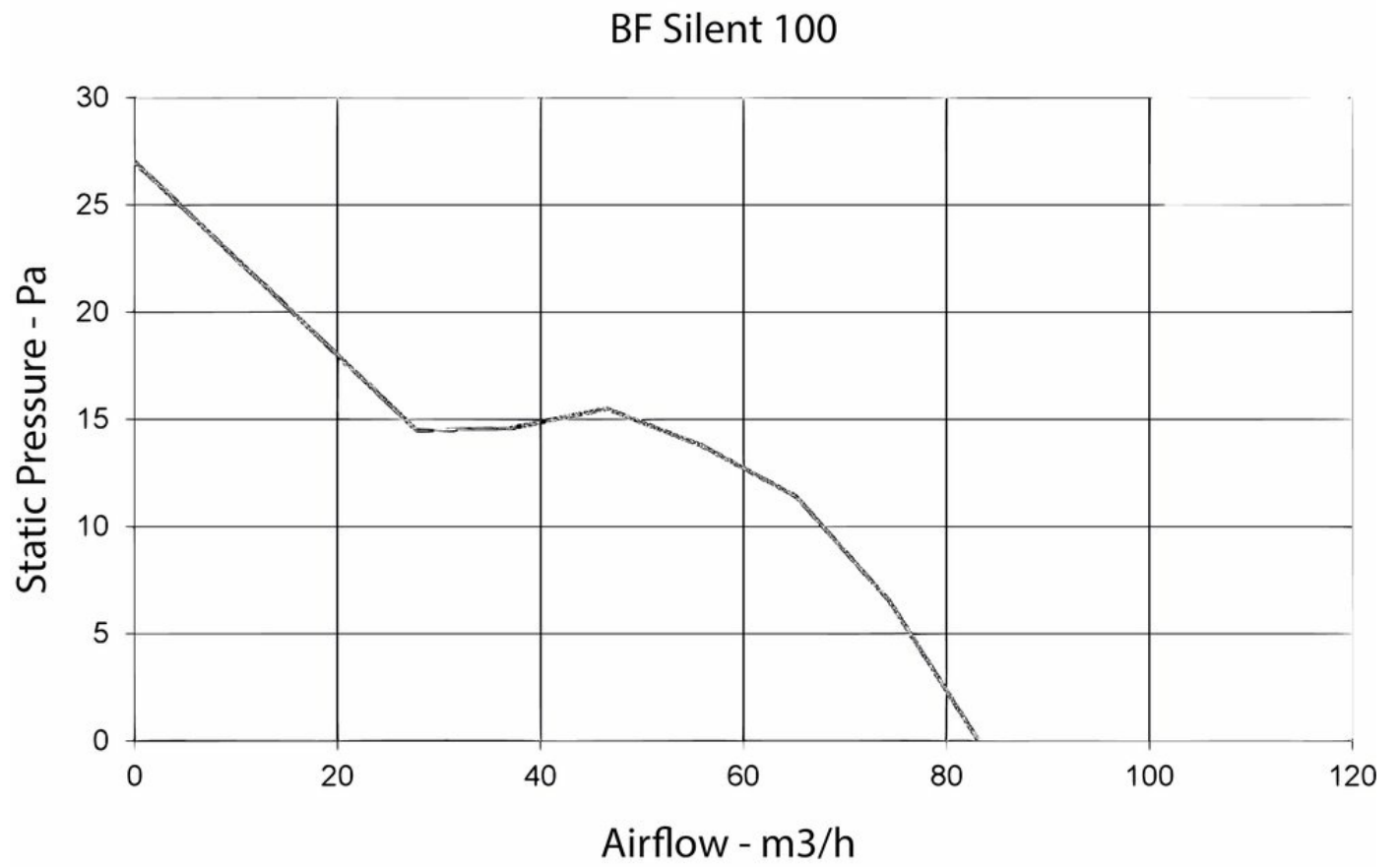

Dimension

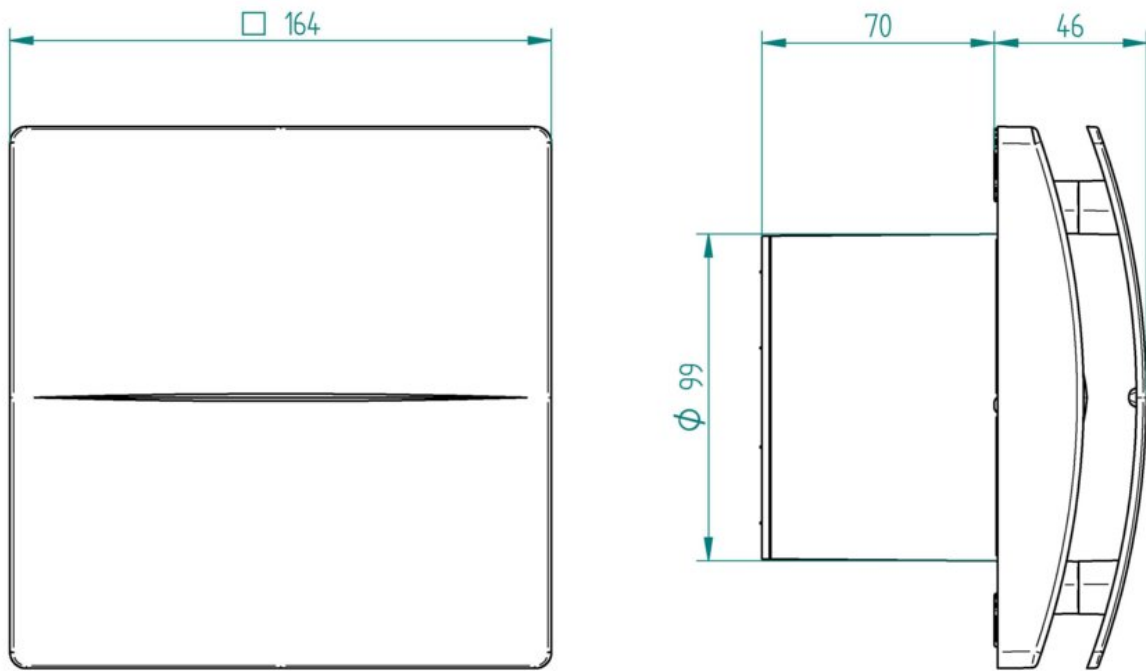

(mm)

Documents

- [INSTALLATION MANUAL BF SILENT.PDF](#)