



HCBB/HCBT

5603999400 - HCBB/4-450/H-A (230V50HZ) V5 - PLATE MOUNTED AXIAL FLOW FANS



Range of low profile plate mounted axial fans fitted with aluminium impellers and single phase motor (HCBB), IP65, Class F insulation, equipped with thermal protection*.
*Except models Ø 800 to 1000.

Motors

Available, depending upon the model, with single or three phase motors in 4 or 6 poles. All motors are speed controllable by autotransformer except models /4-630, B/710, T/4-710, T/800, T/900 and T/1000.

Electrical supplies:

Single phase 230V-50Hz.

(Capacitor located inside the wiring terminal box).

Trade S&P model HCBB/4-450/H-A (230V50HZ) V5

Theoretical Working Point

Airflow	-
Static Pressure	0,000 N/m ²
Temperature	20 °C
Altitude	0 m
Density	1,2 kg/m ³
Frequency	50 Hz

Construction

Discharge diameter	450 mm
Fan size	450
Blades	7
Weight	15,75 kg

Motor Characteristics

Number of poles	4
Voltage	1-230V-50Hz
Maximum absorbed current	2,8 A
IP Rating	IP65
Motor insulation class	F

Working Point

Fan speed	1410
-----------	------

Drawing

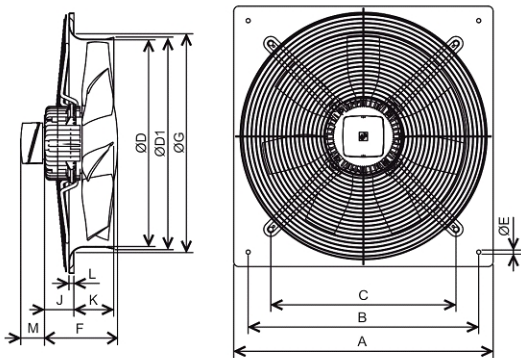

A	B	C	D	D1	E	F	G	J
560	480	400	450	457	10	150	476	48
K	L	M						
91	12	65						

Performance Chart

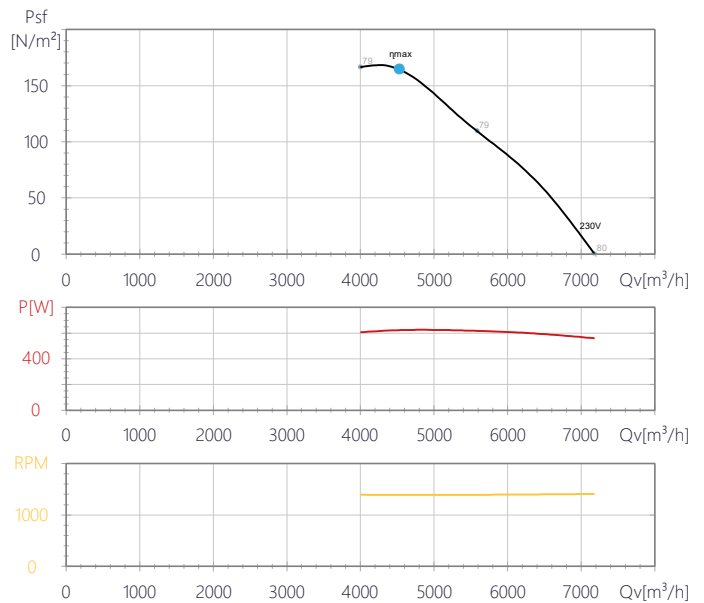



HCBB/HCBT

5603999400 - HCBB/4-450/H-A (230V50HZ) V5 - PLATE MOUNTED AXIAL FLOW FANS

Sound Performance

	63	125	250	500	1k	2k	4k	8k	Overall
Inlet (LwA)	47	66	63	69	76	75	70	63	80
Inlet LpA @ 1m	36	55	52	58	65	64	59	52	69





HCBB/HCBT

5603999400 - HCBB/4-450/H-A (230V50HZ) V5 - PLATE MOUNTED AXIAL FLOW FANS

ErP Data

Maximum efficiency %	33,2
Installation type	A
Category efficiency	Static
N	N40,8
Variable speed drive	+
Year of manufacture	Product Rating Plate
Manufacturer's Info	S&P
Product code	5603999400
Input power at optimum efficiency point (kW)	0,623
Airflow at optimum efficiency point [m3/h]	4.538
Pressure at optimum efficiency point [Pa]	164
Speed at optimum efficiency point	1390
Specific Ratio	1
Recycling/disposal	Instruction Manual
Maintenance	Instruction Manual
Additional components	Catalogue and according to ISO 5801