

GIGADAPTERS, SURFACE-MOUNT TO THROUGH-HOLE ADAPTERS WITH DC TO 3+ GHZ BANDWIDTH

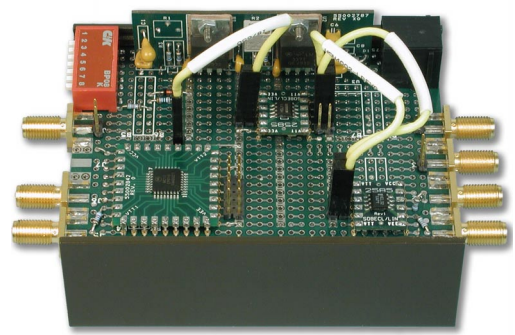
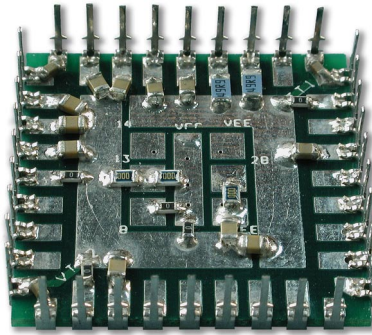
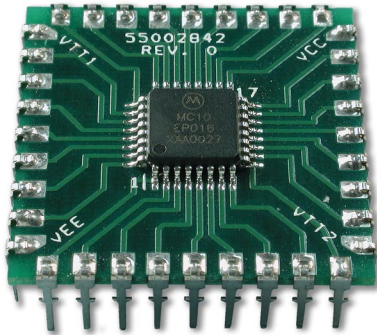

Applications

- Prototyping GHz Logic Functions
- High Speed Digital Communications
- Wireless RF Microwave Circuits and Systems
- Wideband Linear Circuits
- High Speed Device Evaluation

Features

- DC to 3+ GHz Operation
- Many supported package types:
 - SO8 to SO20
 - SSO8 to SSO48
 - PLCC20 and PLCC28
 - QFP-32 to QFP-64
- Optimized for logic, linear, and RF devices
- Multi Layer Board with power and GND Planes
- On Board I/O and Decoupling Component sites
- Custom Motherboards for GHz Prototyping
- Low Cost and Easy to use

Description

The Gigadapters are a family of surface-mount adapters that convert many popular SO, SSO, PLCC, and QFP packages to through-hole footprints with standard, 100-mil pin spacing. Our patented design preserves signal fidelity for low-noise and/or high-speed devices, and some adapters can operate at frequencies up to 3+ GHz. At present, there are 27 models—20 optimized for logic and linear devices, and 7 optimized for RF devices.

These adapters are specifically designed for building GHz logic circuits and RF Microwave circuits, prototype systems and evaluation fixtures. Three reusable Gigadapter motherboards are available for the construction of these systems and test fixtures. For less critical applications, these adapters can also be used with CMOS, TTL and linear devices using standard PC boards with through-hole pads on 100-mil centers, such as circuit boards from our PRL-950, PRL-970 and PRL-980 series custom circuit kits.

Performance

Devices on smaller Gigadapters, such as the MC10EL16 differential receiver (SO8), have been clocked in excess of 3 GHz. The pictured device is an MC10EP016 8-bit programmable frequency divider (QFP-32). Using the Gigadapter motherboard and 50 Ohm coaxial interconnect modules as shown, this circuit ran at 1.2 GHz, limited only by the MC10EP016 device.

The Patented Gigadapter Design

The Gigadapter design is based on the concept of matched impedance, with controlled impedance I/O lines connected to every device pin. Each adapter has a multi-layer PC board with a specific surface-mount device footprint on one side. On the other side, pads are strategically located under the device footprint for mounting of critical components, such as decoupling capacitors, termination resistors and other series and/or shunt components. These components have very short connections to the device footprint above via feed-through holes as shown in **Figure 2** and **Figure 4**.

Furthermore, each PC board has power and ground planes. These planes are connected to extra pins (in addition to the device pins) for connections to the motherboard. Therefore, none of the device pins needs to be committed before a device is installed. In the SO8 and SO16 adapters, however, the device V_{CC} and V_{EE} pins are connected to the adapter V_{CC} and V_{EE} pins, respectively, through easily-cut, short traces, so that these adapters can be converted for use with linear devices as well. Typical PC layout patterns for an SO8 and SO8RF adapters are shown in **Figure 1** through **Figure 4**, and the corresponding physical adapters with components installed on both sides of the adapters are shown in **Figure 5** through **Figure 8**.

On the linear/logic adapters, controlled impedance I/O lines on top of the adapter board connect the device footprint to the adapter pins directly, as shown in **Figure 1** and **Figure 5**. On the bottom side, $50\ \Omega$ input termination resistors are connected to the V_{TT} plane and decoupling capacitors for the V_{TT} and V_{EE} planes are connected to the V_{CC} (ground) plane, all located directly below the device, as shown in **Figure 6**.

In the RF adapters, I/O lines on top of the adapter board connect the device footprint to a set of intermediate pads on the bottom through vias. These pads allow easy insertion of series components, such as a coupling capacitor, a resistor or a $0\ \Omega$ jumper, between the device footprint and the adapter pin. A center ground strip, as shown in **Figure 4** and **Figure 8**, enables insertion of shunt components between device pins and ground. The center ground strip is also connected to the adapter ground plane.

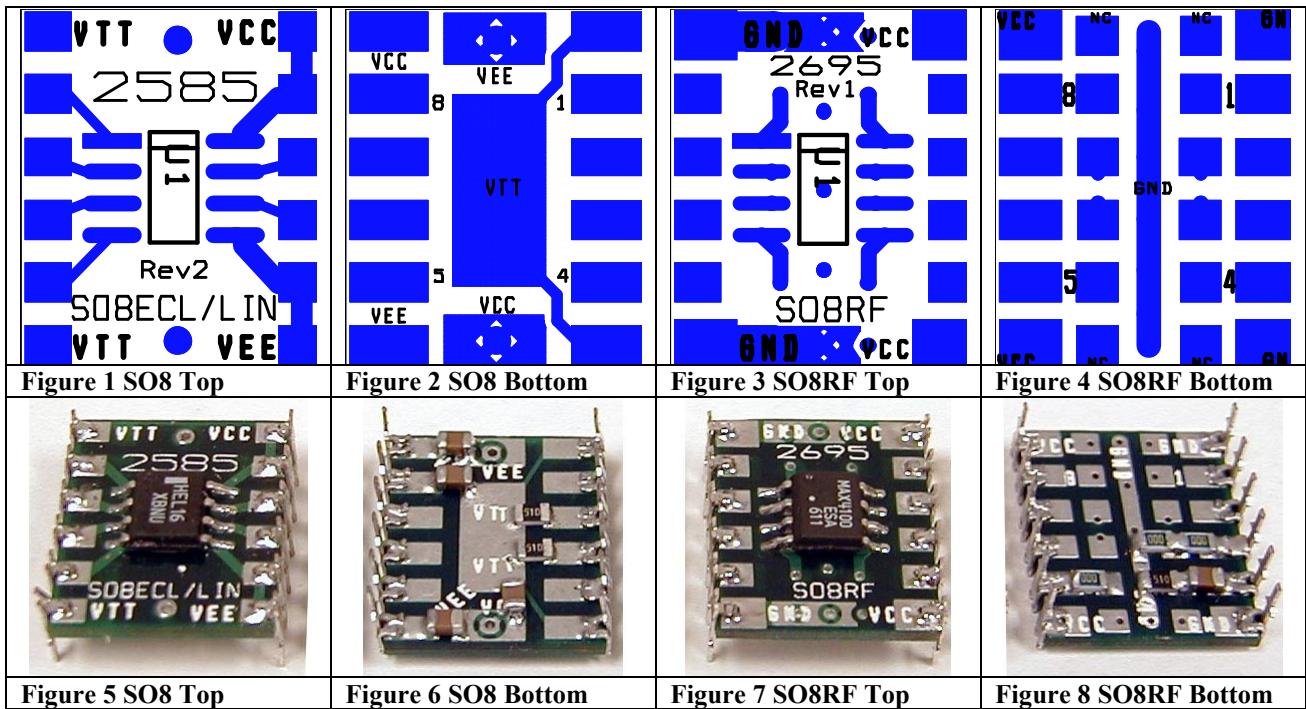

The Wide-body Gigadapters

For the SO and SSO adapters with 20 pins or greater, the increased board width allows for the addition of two connecting strips between the device pads and the center ground strip on the bottom side, as shown in **Figure 10**. This configuration enables a filter network, often connected among several pins for RF devices, to be placed on Gigadapter instead of on the motherboard. An example of this often-used circuit configuration is shown in **Figure 11**, and the component placement is shown in **Figure 12**. Note that **Figure 12** contains all the components shown in **Figure 11**.

Any device pad can be grounded by connecting it to the center ground strip using a #2010 zero Ω jumper. Or, it may be connected to an isolated section (by cutting as shown in **Figure 12**) of one of the two connecting strips first and then connecting the isolated strip to the center ground strip using a smaller, #0850 or #1206, zero Ω jumper.

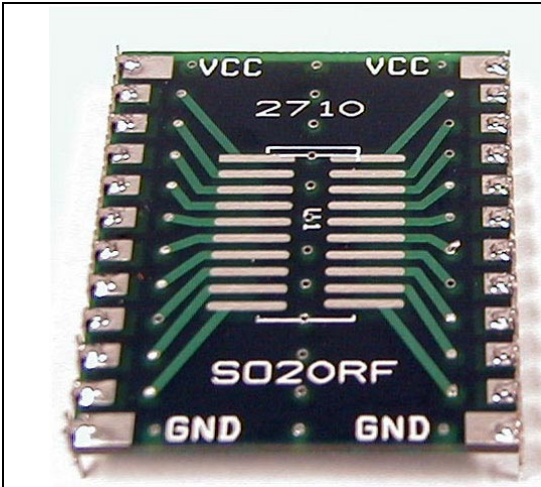

Figure 9 SO20 Top

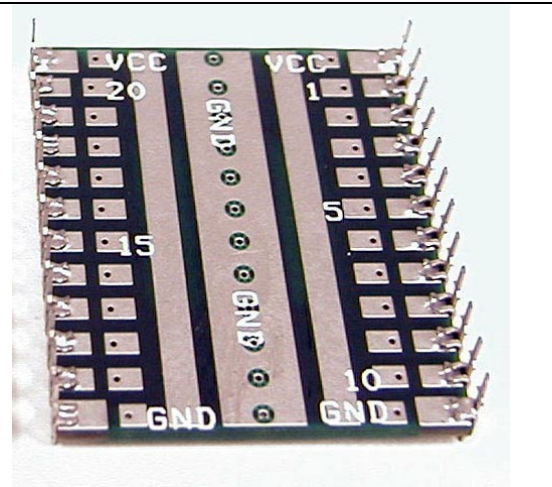

Figure 10 SO20 Bottom

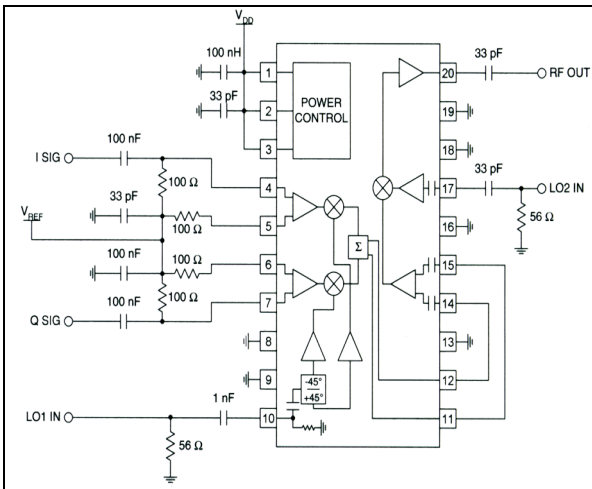

Figure 11 A typical Dual-Conversion Quadrature Modulator Device

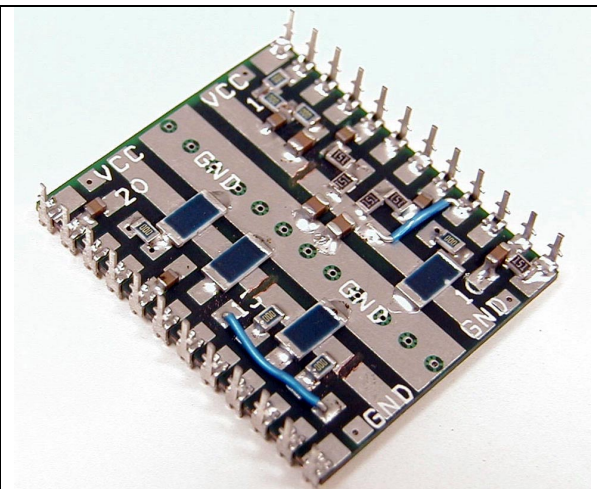

Figure 12 Placement of critical components for the circuit in Figure 11 using an SO20RF adapter

High Frequency Performance Characteristics

High frequency performance characteristics of these adapters were measured first using a specially-designed test board shown in **Figure 13** and then using the GD-970-3.8 motherboard shown in **Figure 14** (Motherboards will be discussed in a later section). In **Figure 13**, 50 Ω microstrip transmission lines connect the SMA I/O connectors to a set of DIP footprints. The device under test was inserted into the test board using very low profile pin sockets. Device rise time, maximum clock frequency and VSWR measurements were made. The same measurements using the same devices were repeated using the GD-970-3.8 motherboard shown in **Figure 14**. Plug-in 50 Ω coaxial interconnect modules connect the SMAs to the device via 0.025-in² x 0.35-in long stick pins. The results are shown below:

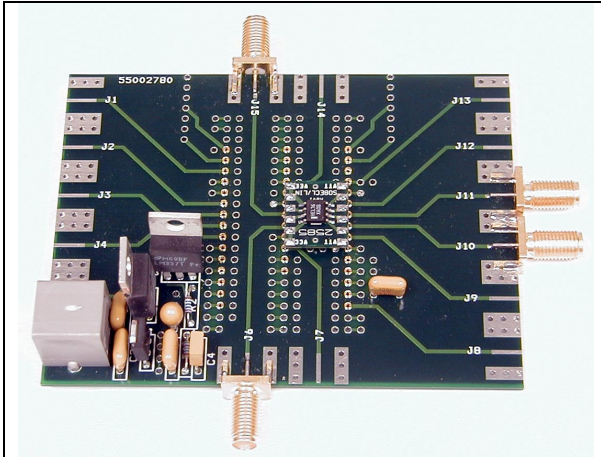

Figure 13 SMT adapter and specially-designed evaluation board

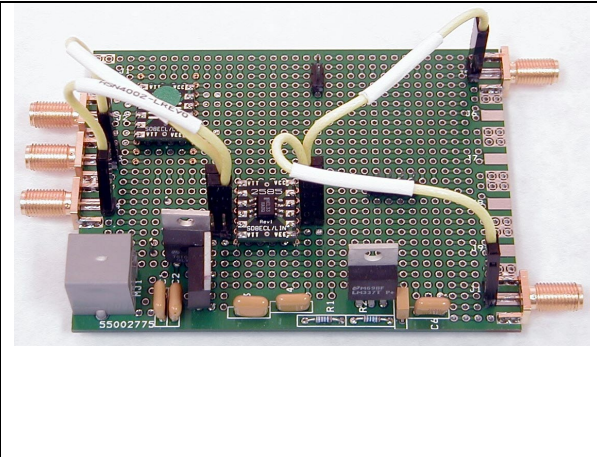

Figure 14 Gigadapter, reusable motherboard, and 50 Ohm plug-in coax modules

Time Domain Test Results

DUT	Device Description	f_{\max} (GHz)		t_r (ps, 10%-90%)	
		Figure 13	Figure 14	Figure 13	Figure 14
MC10EL16	Differential Receiver	N/A	N/A	280	320
MC10EL32	Frequency Divider	> 3	> 3	280	320

The test setup shown in **Figure 13** represents what can be obtained under near-ideal conditions (although slightly better results would have been obtained had sockets not been used). Note that the 10%-90% rise time shown of 280 ps is comparable to the published 20%-80% typical value of 225 ps for these devices, indicating that very little degradation results from using the adapter under near ideal conditions. Results from **Figure 14** represent what can be expected when using a Gigadapter motherboard with the plug-in coaxial interconnect modules.

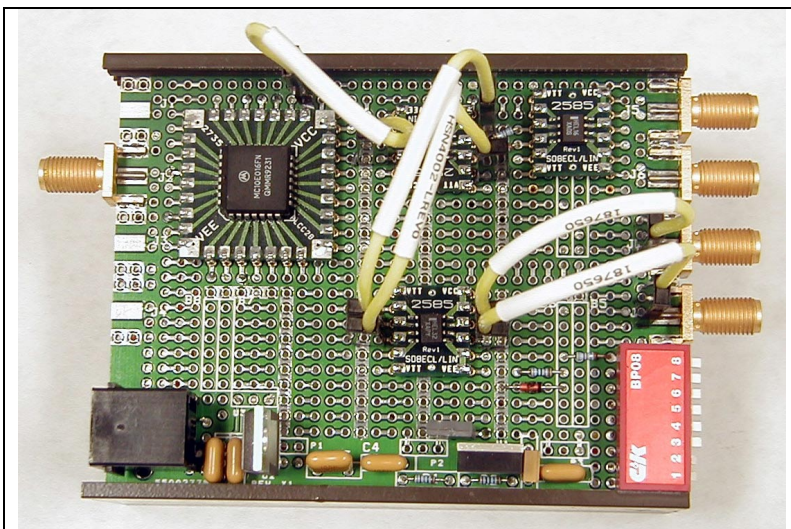

Figure 15

An 8-bit Programmable frequency divider with buffered f/N and $f/2N$ complementary ECL outputs was tested using the GD-970-3.8 Gigadapter motherboard and plug-in 50 Ω coaxial interconnect modules.

f_{\max} of 950 MHz was limited by the MC10E016.

Frequency Domain Test Results

A similar test set up was used for the frequency domain measurements. VSWR was measured for 50 Ω -terminated input pins for an SO8 and an SO28RF adapter. It was found that, when an unused pin adjacent to the test pin was grounded, significant improvement of the VSWR value resulted. In **Figure 18**, even the longest trace of the adapter, pin one, has a respectable VSWR at 1 GHz.

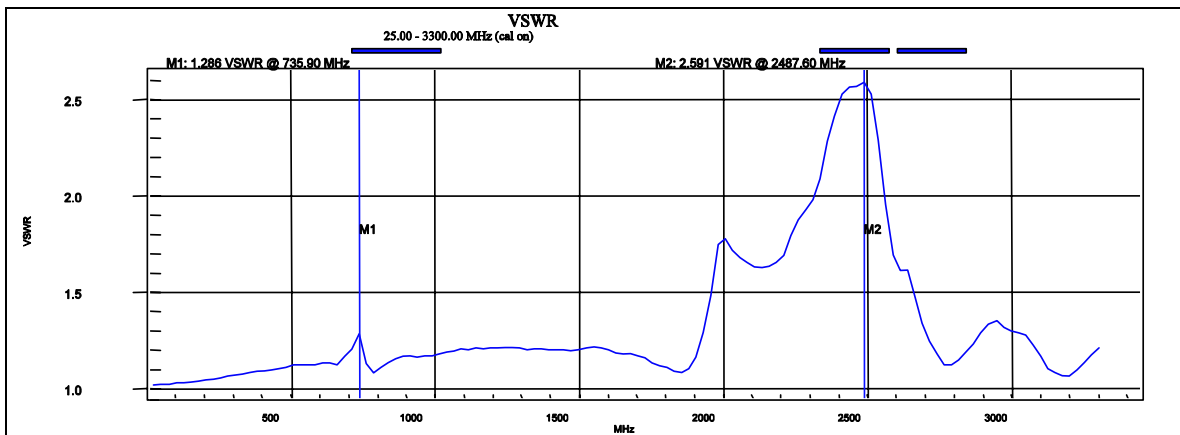

Figure 16 GD-SO8, Pin 2 & Pin 3 terminated into 50 Ω , Pin 1 and Pin 4 grounded

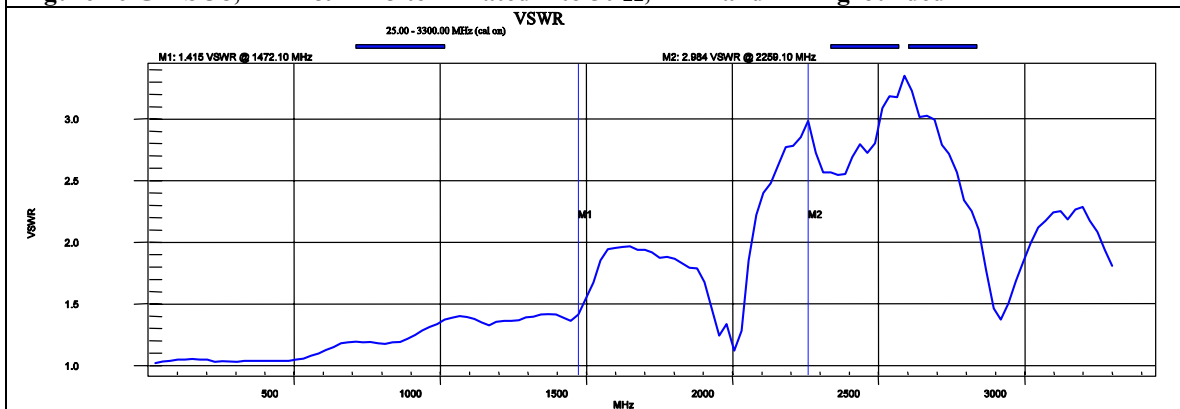

Figure 17 GD-SO28RF, Pin 6 terminated into 50 Ω , Pin 5 and Pin 7 grounded

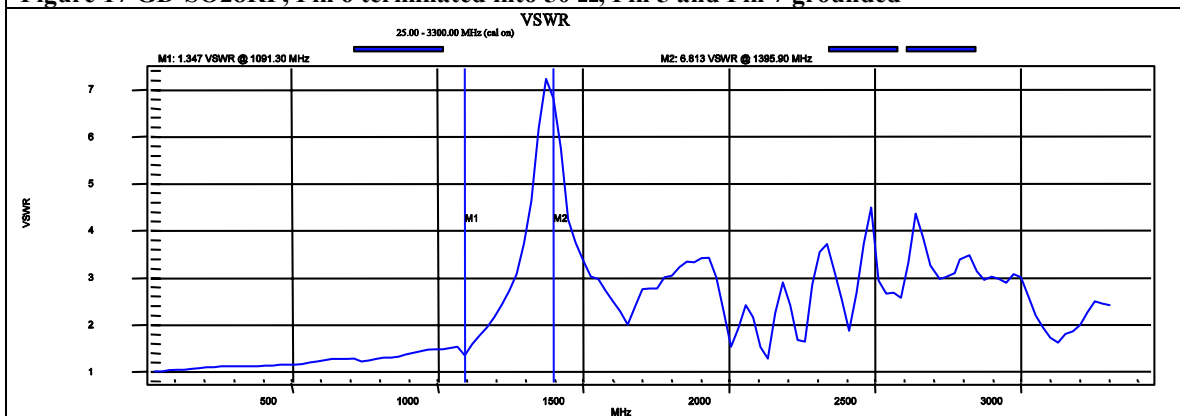

Figure 18 GD-SO28RF, Pin 1 terminated into 50 Ω and Pin 2 grounded

Gigadapter Motherboards

Although PRL Gigadapters can be used with any standard breadboard on 100-mil spacing, the PRL Gigadapter Motherboards provide several key features to enhance performance and speed up prototyping. Each Gigadapter motherboard has specially designed Gigadapter “sites” that provide for short connections to power and ground. A “three-pads-per-pin” pattern also permits the use of stick-pins and 50 Ω coax interconnect modules to ensure matched-impedance connections to other Gigadapters or to other parts of your circuit.

There are currently three Gigadapter motherboards for use with PRL surface-mount adapters. Each is supplied with a power jack and a power cable. The component side has a ground plane. The GD-970-3.8 board has both the 2-pads-per-pin and 3-pads-per-pin patterns. The larger GD-980-8 board has the 3-pads-per-pin pattern plus areas for high-speed data I/O connectors. Each motherboard can accommodate a variety of Gigadapter combinations:

Model	Gigadapter Sites			Connector Footprints		
	A-type	B-type	C-type	SMA/ BNC	Voltage Regulator & AC jack	Other
970-3.8	3	2	0	8 SMA	Yes	8-pos DIP switch
970-3.8A	11	0	0	6 SMA/BNC	Yes	Uncommitted space for PRL I/O SIP adapters
980-8	20	4	2	8 SMA/BNC	Yes	Large uncommitted areas for PRL I/O SIP adapters

- A sites accept SO or SSO device adapters from 8 to 30 pins, depending on the motherboard. A sites are continuous, and will accept a varying number of SO/SSO device adapters depending on size. Best-case adapter count is shown, based on SO8 adapters.
- B sites accept PLCC/LCC device adapters from 20 to 28 pins, or a QFP-32 adapter. B sites will also accept SO/SSO adapters up to 30 pins.
- C sites will accept QFP device adapters from 44 to 64 pins, or SO/SSO adapters up to 30 pins.

All boards are laid out on a 100-mil grids, allowing for placement of all standard through-hole components, connectors and I/O SIP adapters

GD-970-3.8

The GD-970-3.8 motherboard shown in **Figure 19** is designed for use with the PRL-970-3.8EX extrusion, and has sites for up to 5 Gigadapters as shown above. On board circuitry supports either three discrete voltage regulators, V_{CC} (U3), V_{EE} (U2) and V_{TT} (U1), or one of the four optional voltage regulator SIP Modules, to be inserted into locations marked P1, P2 and P3 (See items under Power Supplies).

There are two voltage busses either under or adjacent to each Gigadapter site. Strategically placed ground busses and ground pads are provided for coaxial cable terminations and for power supply decoupling. A footprint for an 8-position DIP switch, SW1, is also included.

An SO8 Gigadapter with an MC10EL32 frequency divider was tested for clock rates over 3 GHz on this board using plug-in 50 Ω coaxial interconnect modules.

GD-970-3.8A

The GD-970-3.8A motherboard shown in **Figure 20** is designed for use with the PRL-970-3.8EX extrusion, and has sites for up to 11 Gigadapters as shown above. On board circuitry supports one of four optional voltage regulator SIP Modules, to be inserted into locations marked P1, P2 and P3 (See items under Power Supplies).

There are two voltage busses either under or adjacent to each Gigadapter site. Strategically placed ground busses and ground pads are provided for coaxial cable terminations and for power supply decoupling. A “universal” footprint permits installation of either BNC or end-launch SMA connectors in any combination, up to 6 connectors. Uncommitted space at the board edge can be used for our patented I/O SIP adapters.

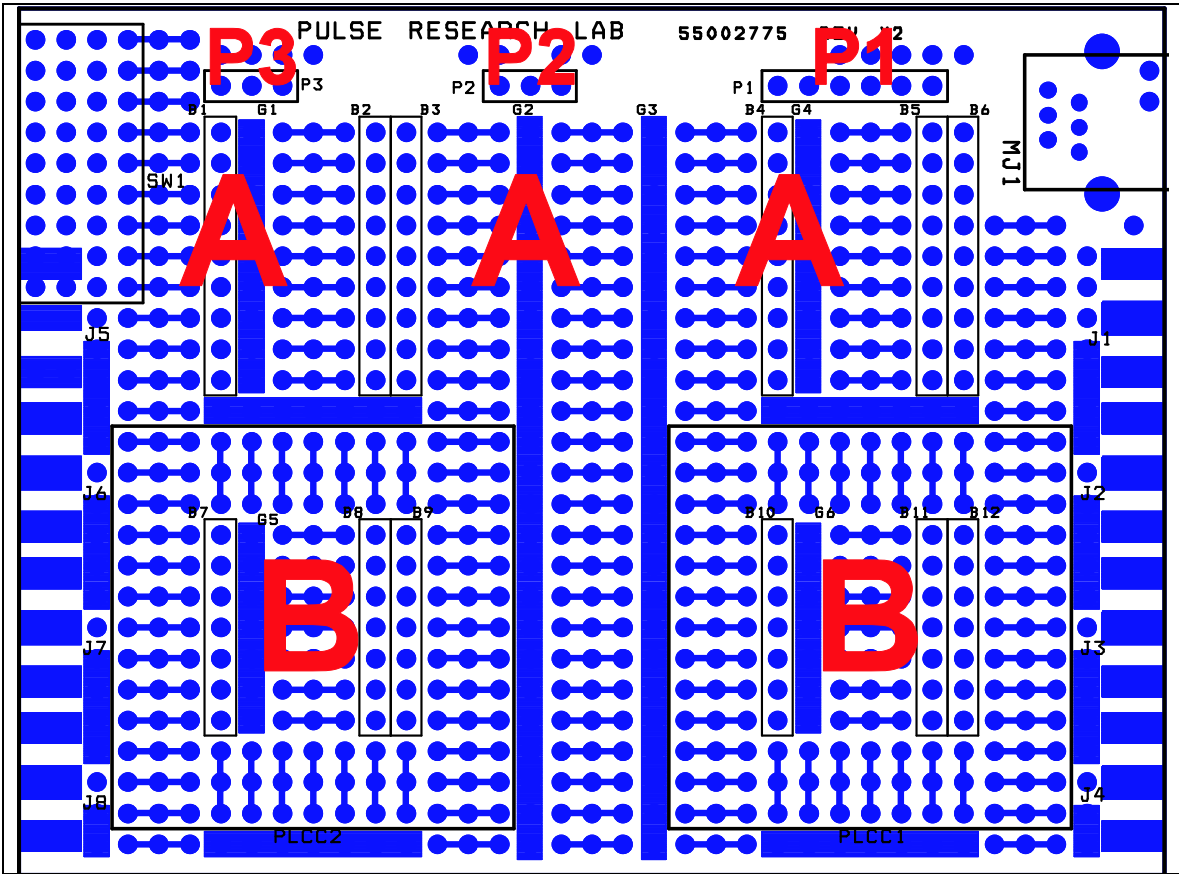

Figure 19 GD-970-3.8 Gigadapter Motherboard: 2.8-in. W x 3.7-in. L

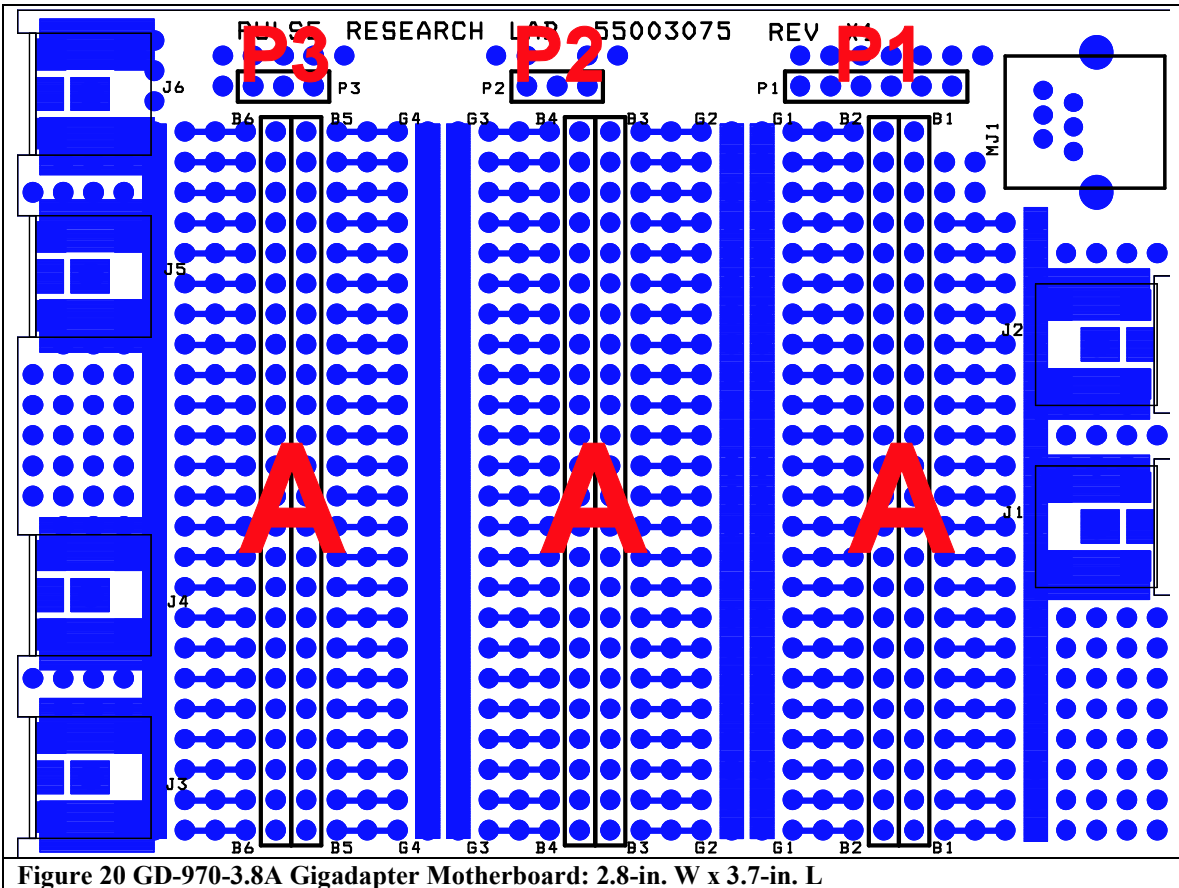

Figure 20 GD-970-3.8A Gigadapter Motherboard: 2.8-in. W x 3.7-in. L

GD-980-8

The GD-980-8 motherboard shown below in **Figure 21** is designed for use with the PRL-980-8EX extrusion, and has sites for up to 26 Gigadapters as listed above. On board circuitry supports one of the five optional voltage regulator SIP Modules, to be installed on the board as specified (See items under Power Supplies).

There are two voltage busses under each **A** site, three under each **B** site and four under each **C** site. Each side of an adapter site has an adjacent ground bus, so that a pair of stick pins can be placed next to each device pin for connection to a plug-in coaxial interconnect module.

A “universal” footprint permits installation of either BNC or end-launch SMA connectors in any combination, up to 8 connectors. Large uncommitted areas at the board edge can be used for our patented I/O SIP adapters, including 25-pin D connectors and 40-pin header connectors for high-speed control and data I/O.

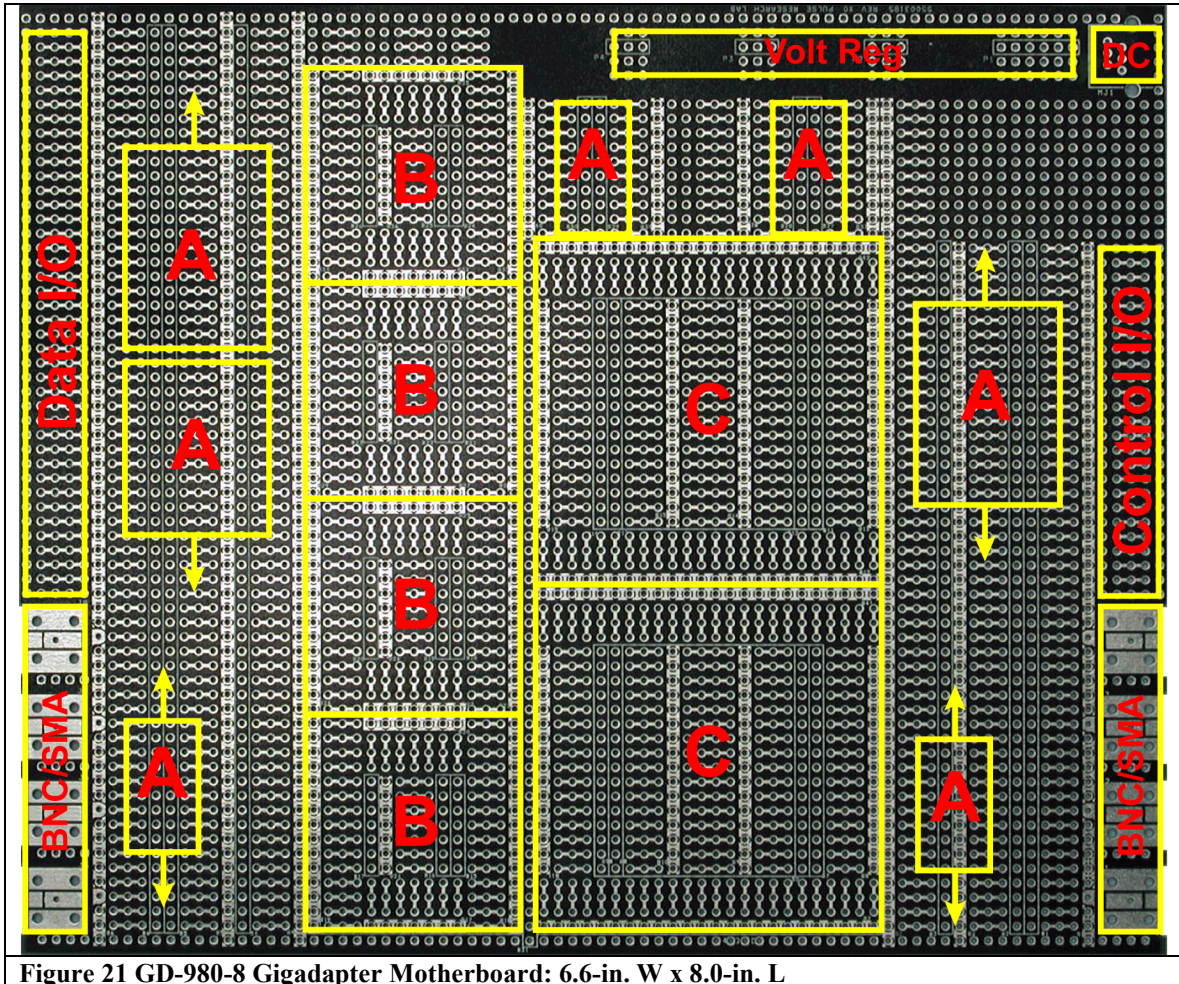

Figure 21 GD-980-8 Gigadapter Motherboard: 6.6-in. W x 8.0-in. L

Interconnecting Gigadapters On The Motherboard

There are several options for interconnecting Gigadapters on a motherboard, depending on the distance between the components to be interconnected. In the time domain, when an interconnect distance, measured in transit time, exceeds $t_r/5$, it must be treated as a transmission line, where t_r is the 10%-90% rise time of the signal. In the frequency domain, it is $\lambda/20$, where λ is the wavelength of the signal.

Using the MC10EL16, for example, the 10%-90% rise time is about 250 ps. Therefore, $t_r/5$ is 50 ps. Assuming FR-4 is the PC board material, the propagation delay (a function of the dielectric material only) is approximately 150 ps per inch. This translates to a maximum physical distance of 0.3-in. In the frequency domain, the wavelength of a 1 GHz signal is 30 cm, or 11.8-in. For the same FR-4 material, the maximum distance is approximately 0.59-in.

When the interconnect distance is ≤ 0.3 -in., a wire jumper, a zero Ω chip jumper or a 1.2 Ω resistor will do. In fact, the 1.2 Ω , 1/3 W space-saver resistor, which fits very nicely into a 0.3-in. spacing, is a better choice than a wire jumper, because it provides some damping effect against ringing and oscillations.

When the interconnect distance exceeds the critical limit, one must use a transmission line connection. Teflon insulated miniature coax such as the RG178 or the 0.8 mm semi-rigid coax, CA50034, from Precision Tube, shown in **Figure 22** below, provides adequate performance up to about 3.5 GHz.

Plug-in 50 Ω coaxial interconnect modules, shown in **Figure 23** and **Figure 25**, are easy to connect and disconnect and are reusable. Bandwidth for 4-in. to 8-in. segments is better than 2.5 GHz. These modules are intended for use with 0.35-in. long, 0.025-in.² stick pins. Low-profile pin sockets shown also facilitate circuit component changes.

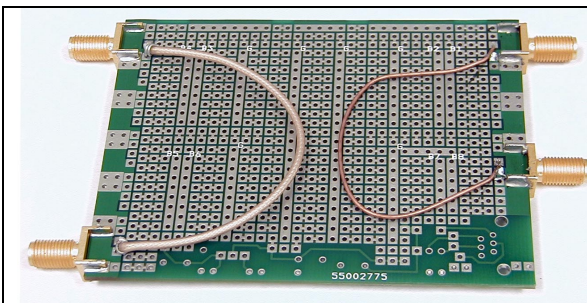

Figure 22 Miniature coaxial cable interconnections.

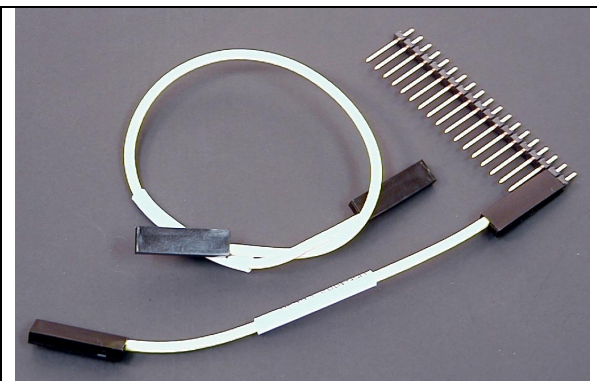

Figure 23 50 Ω coaxial interconnect modules and 0.025-in.² x 0.35-in. stick pins.

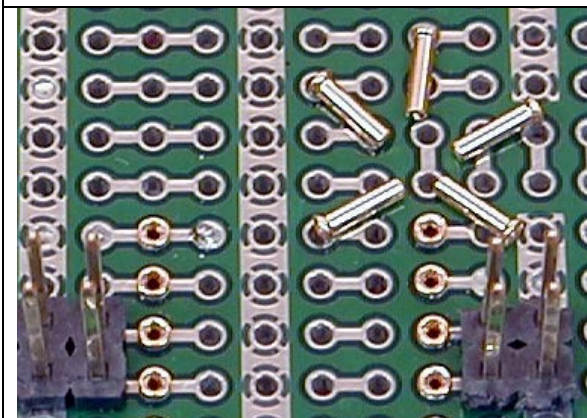

Figure 24 Low profile pin sockets and stick pins on a Gigadapter motherboard

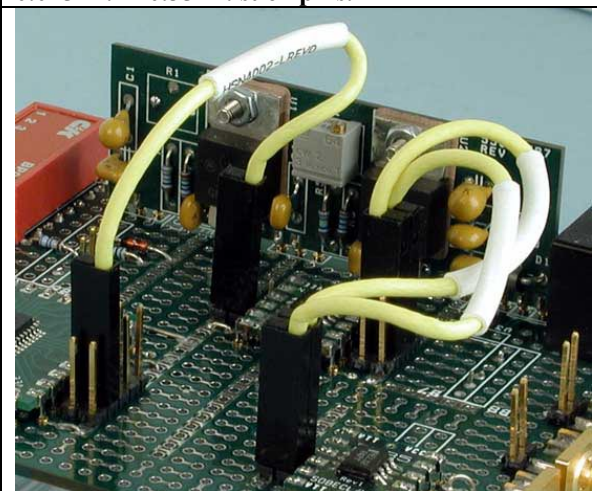

Figure 25 50 Ω coax interconnect modules and stick pins on a Gigadapter motherboard

Power Supplies: AC/DC Adapters And Voltage Regulator SIP Modules

Most RF microwave devices require just a single positive supply voltage. For ECL devices, a -5 V or -5.2 V supply is generally sufficient. To conserve power, however, a -2 V supply for the termination voltage V_{TT} is often used. For PECL devices, $+5\text{ V}$ and $+3\text{ V}$ V_{TT} supplies are used. Low voltage PECL devices require $+3.3\text{ V}$ and a $+1.3\text{ V}$ V_{TT} supplies.

AC/DC Adapters: 115V/60Hz AC Input—Single and Dual Unregulated Outputs

Model#	Output
15000020	+12 V/500 mA, w/2.1 mm plug
15000040	-12 V/800 mA, w/2.1 mm plug
PRL-760A	$\pm 8.5\text{ V}/1.4\text{ A}$, with modular plug

The 15000070, $\pm 8.5\text{V}/750\text{mA}$, adapter is optimized for logic circuit applications, using ECL, PECL, CMOS and TTL devices.

The 150000060 is intended for high current ECL applications only.

The 15000020 and 15000040 are used with many current products and are suitable for linear circuit applications as well.

Multiple circuits can be powered from a single AC adapter by using our PRL Voltage Distribution Modules.

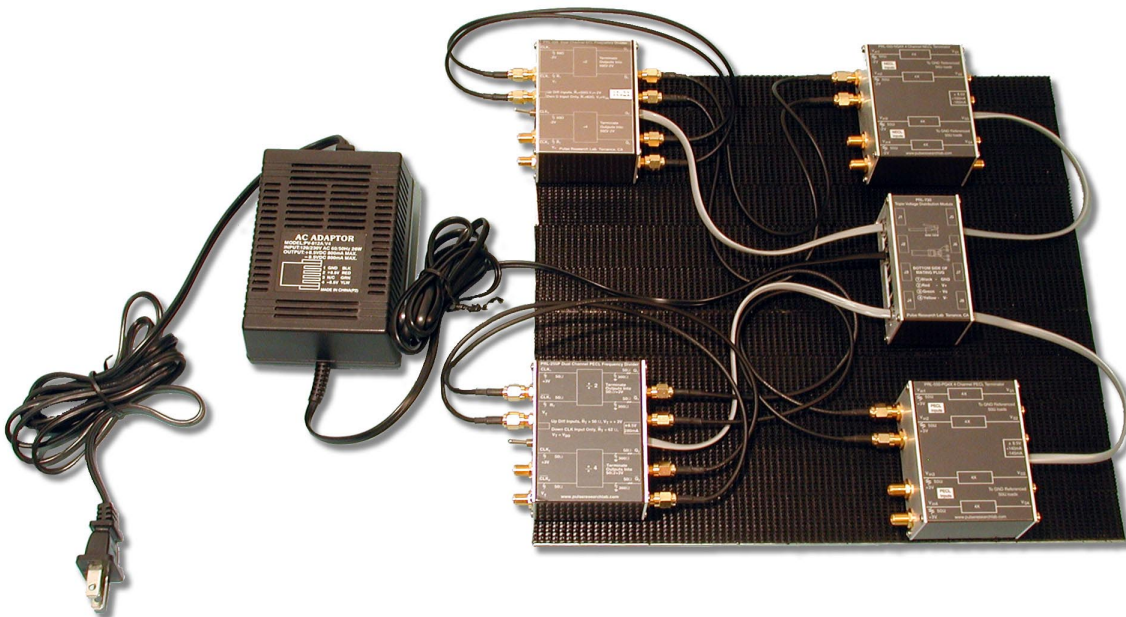

Figure 26 Four Basic Lab Tools modules powered from a PRL-730 Triple Voltage Distribution Module

Voltage Regulator SIP Modules:

Model No.*	Description	Application	Vo1	Vo2	Vo3	Vo4	Size: H x L	Vin - Vo **
56002777	Single Positive Output	TTL/CMOS	3.3 V to 5.5 V, 300 mA	NA	NA	NA	0.825" x 1.5"	3 V to 6 V
56002787	Dual Negative Outputs, V _{EE} and V _{TT}	ECL, LVECL	NA	-3.3 V to -5.5 V, 300 mA	NA	-2 V, 100 mA	0.825" x 2.4"	3 V to 6 V
56002797	Positive & Negative Outputs, V _{CC} and V _{EE}	Linear, TTL, CMOS	3.3 V to 5.5 V, 300 mA	-3.3 V to -5.5 V, 300 mA	NA	NA	0.825" x 2.4"	3 V to 6 V
56002807	Three Outputs, V _{CC} , V _{EE} , V _{TT}	ECL, Linear, TTL, CMOS	3.3 V to 5.5 V, 300 mA	-3.3 V to -5.5 V, 300 mA	NA	-2 V, 100 mA	0.825" x 3.0"	3 V to 6 V
56002817	Four Outputs, V _{CC} , V _{EE} , V _{TTN} and V _{TTP}	ECL, PECL, Linear, TTL	3.3 V to 5.5 V, 500 mA***	-3.3 V to -5.5 V, 500 mA***	+3 V, 200 mA	-2 V, 100 mA	1.7" x 4.5"	3 V to 6 V
56002867	Dual Positive Outputs	CMOS Imager	3.3 V to 5.5 V, 300 mA	NA	3.3 V to 5.5 V, 300 mA	NA	0.825" x 2.4"	3 V to 6 V

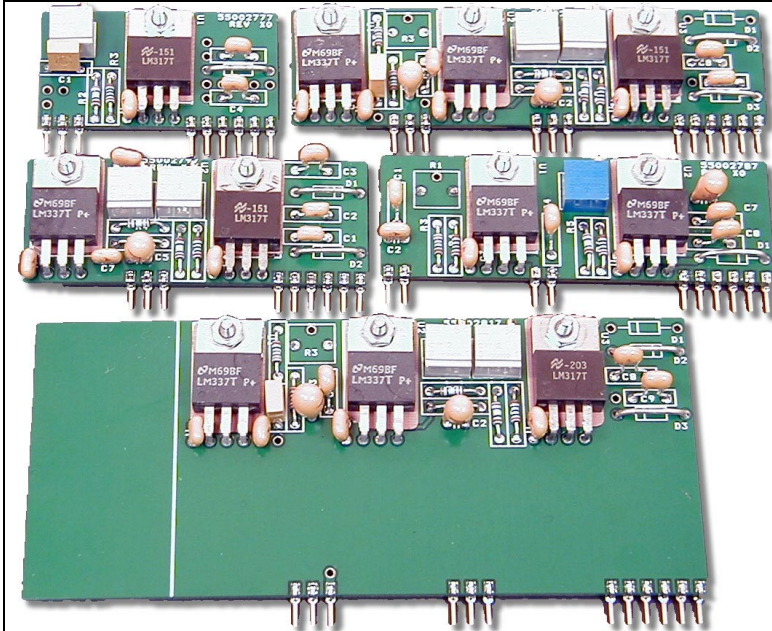

Figure 27 Assorted Voltage Regulator SIP Modules

These Voltage Regulator SIP Modules are designed for use with the Gigadapter Motherboards but can also be used with PC boards in the PRL-Series Custom Circuit Kits or any conventional circuit board with pads on 100-mil centers. All SIP modules can be powered by the PRL-760, ± 8.5 V/1.4 A, AC/DC adapter.

The 54002817 SIP module is intended for use with the GD-980-6 motherboard and the PRL-980 series extrusions. It can also be used with pc boards in the PRL-970 series if the aluminum enclosure is not used.

*Other output voltages available on custom orders.

**With cooling, higher input voltages can be used. Max |Vin - Vo| should be limited to 8V.

Supported Device Package Types/Footprints

PC layout patterns, or footprints, for the entire Gigadapter family are shown below. Additional Gigadapters are constantly being developed.

SO Adapter Family (supports “SO” and “SOP” packages)

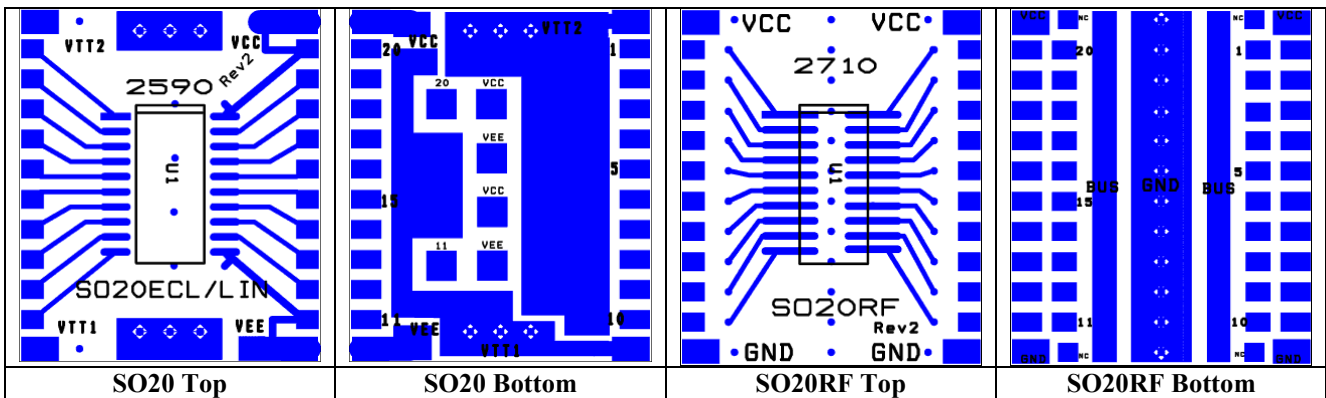
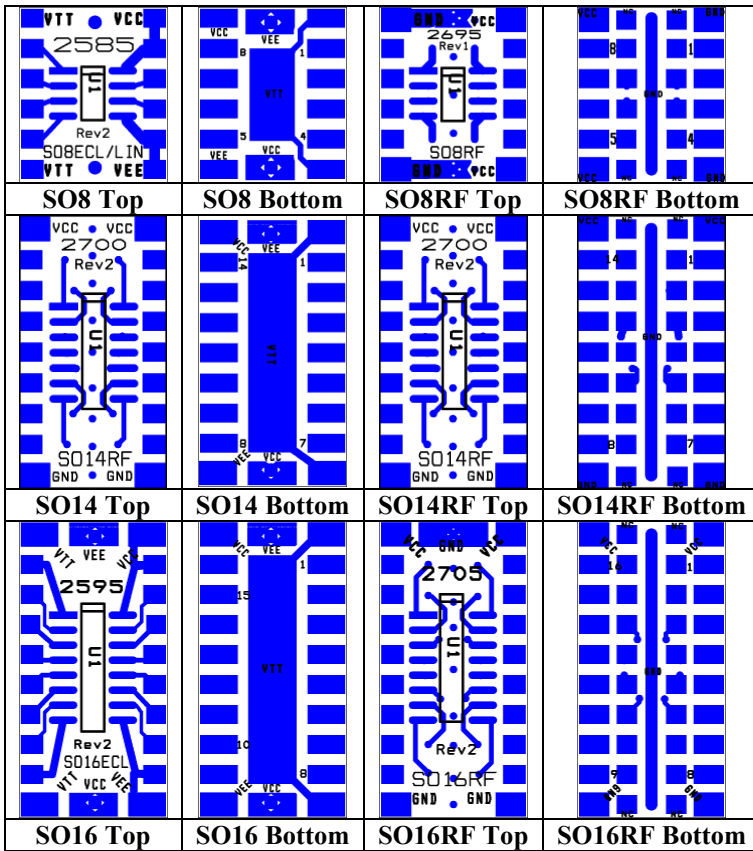

SSO Adapter Family (supports “SSO,” “SSOP,” and “TSSOP” packages)

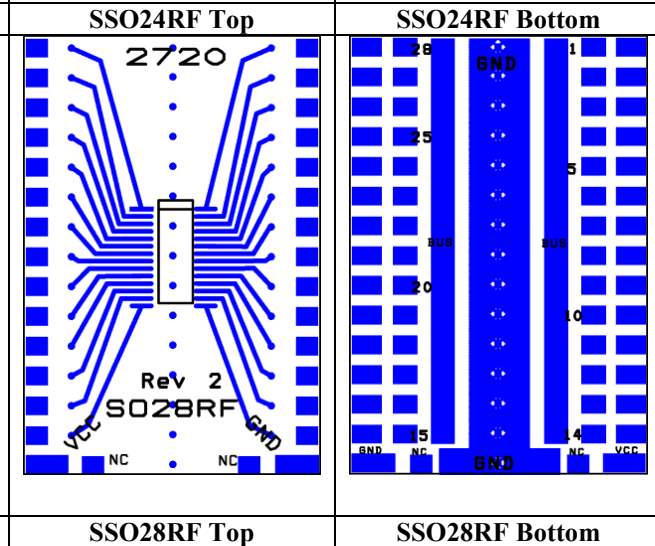
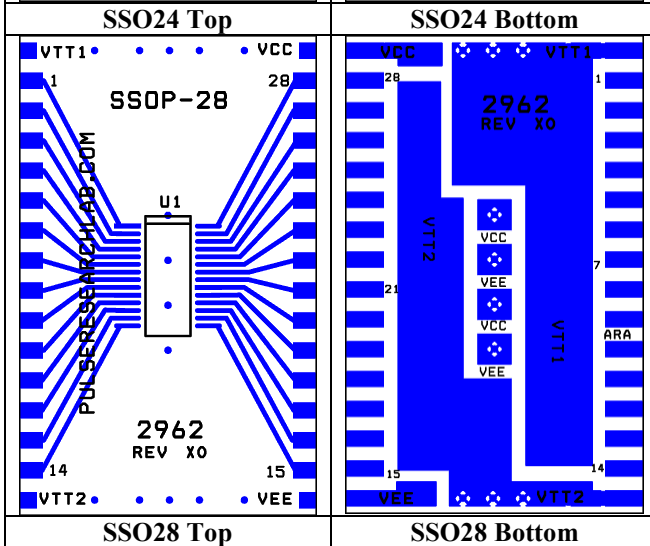
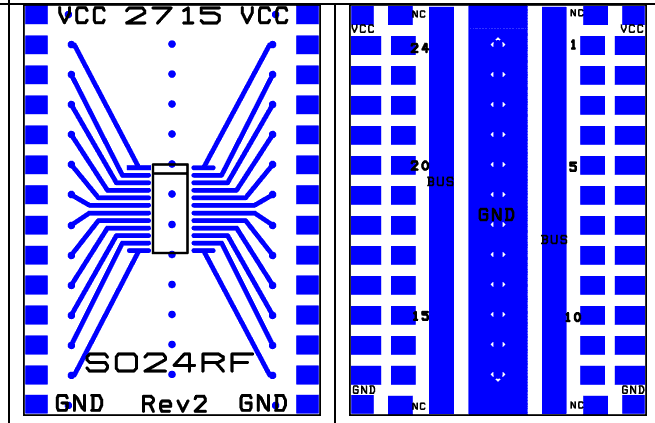
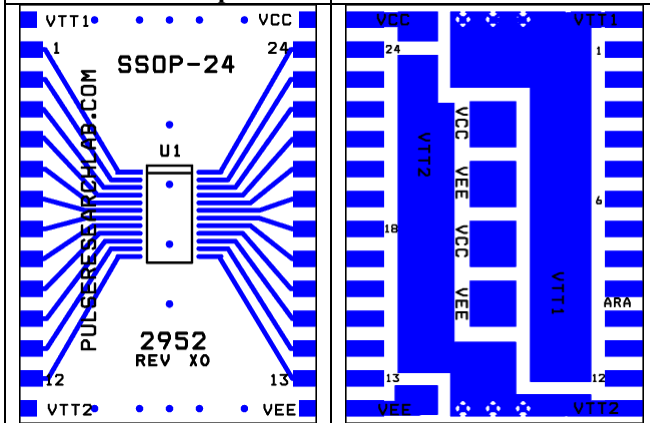
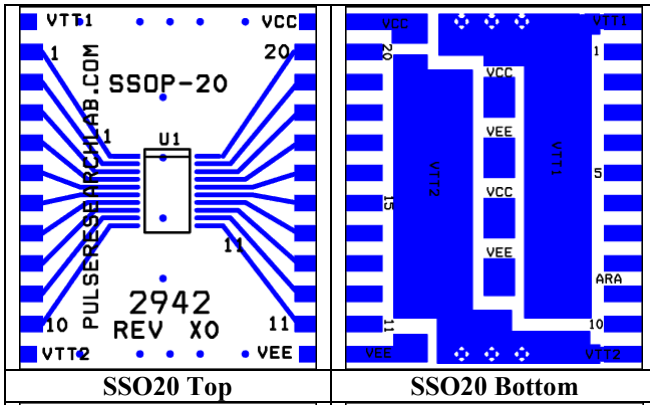
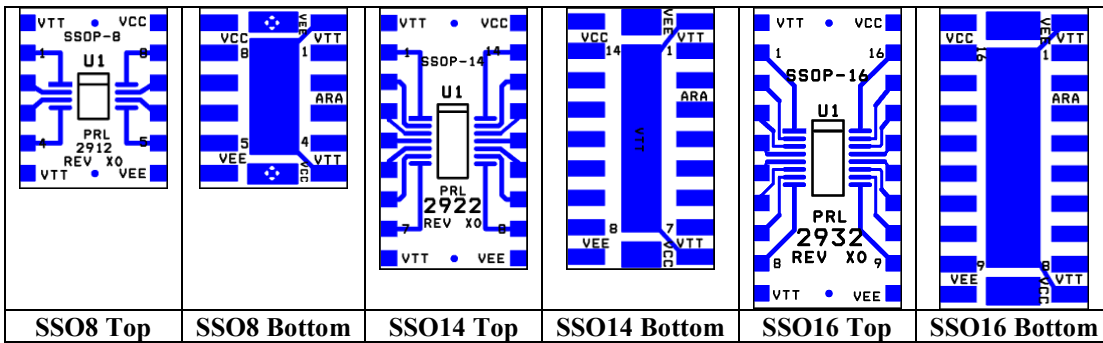

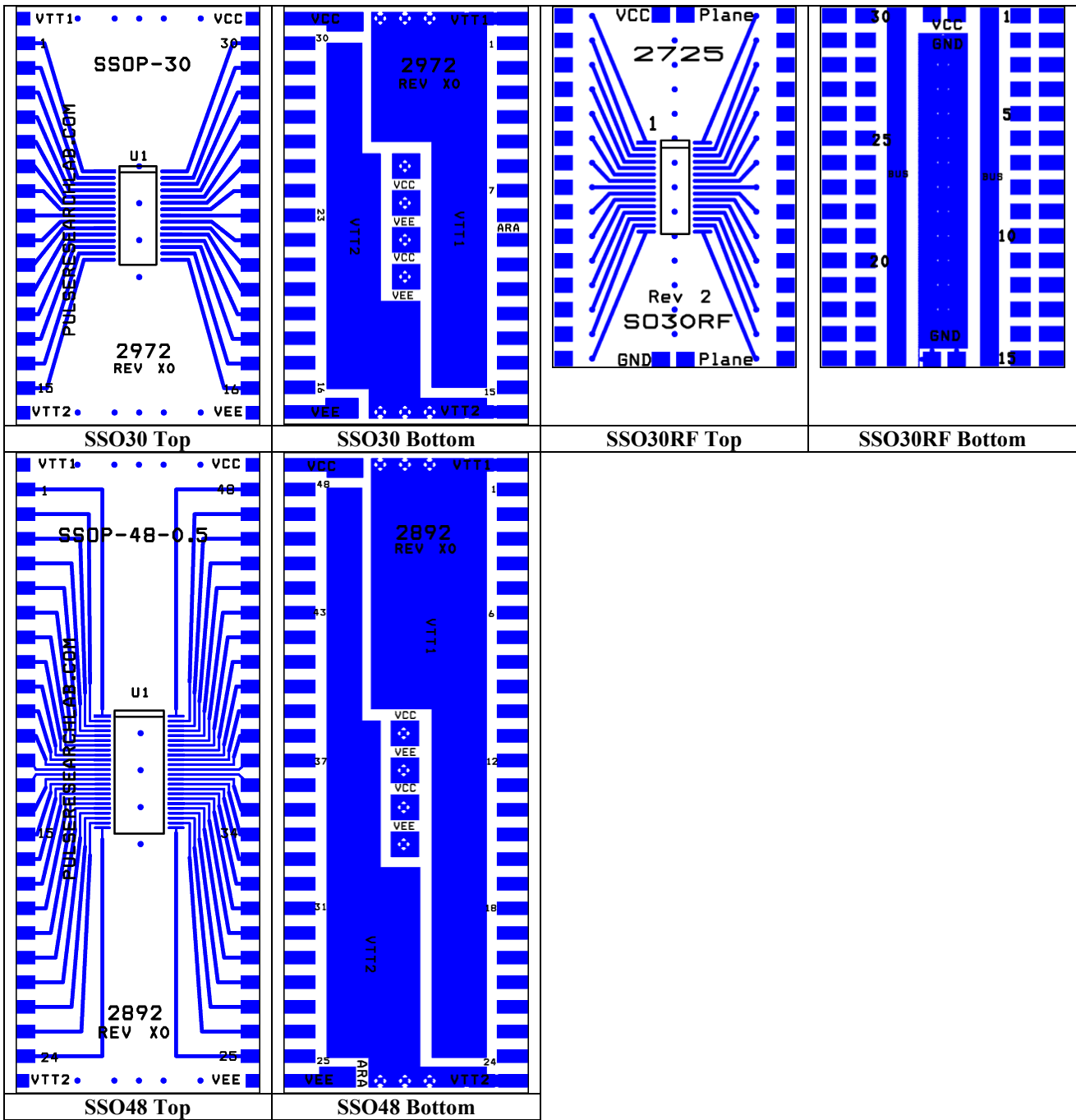

LCC Adapter Family (supports "LCC," "PLCC," and "CLCC" packages)

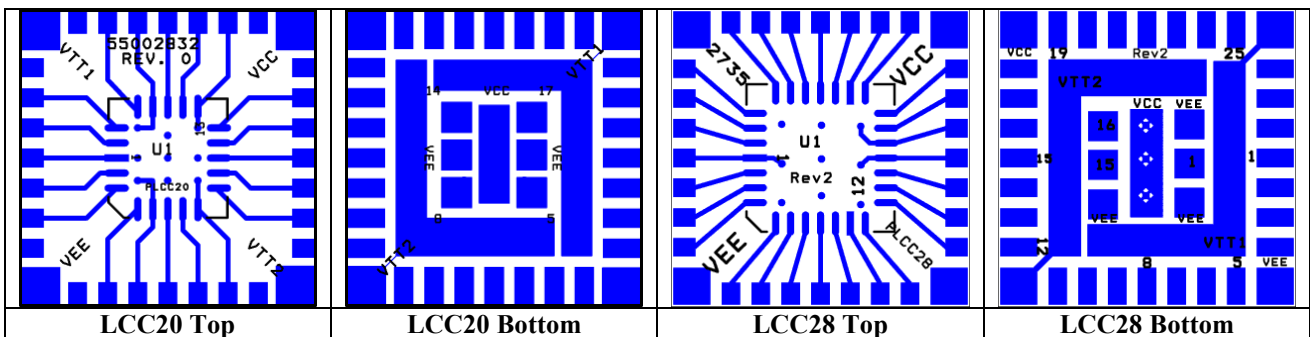

QFP Adapters (supports “QFP,” “TQFP,” “PQFP,” and “MQFP” packages)

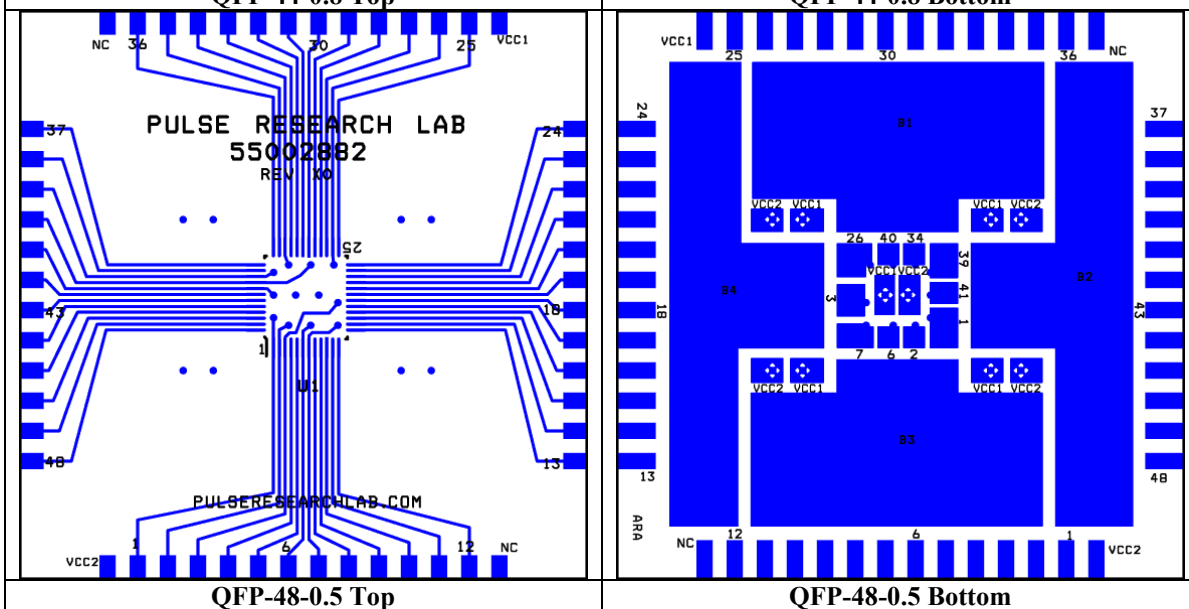
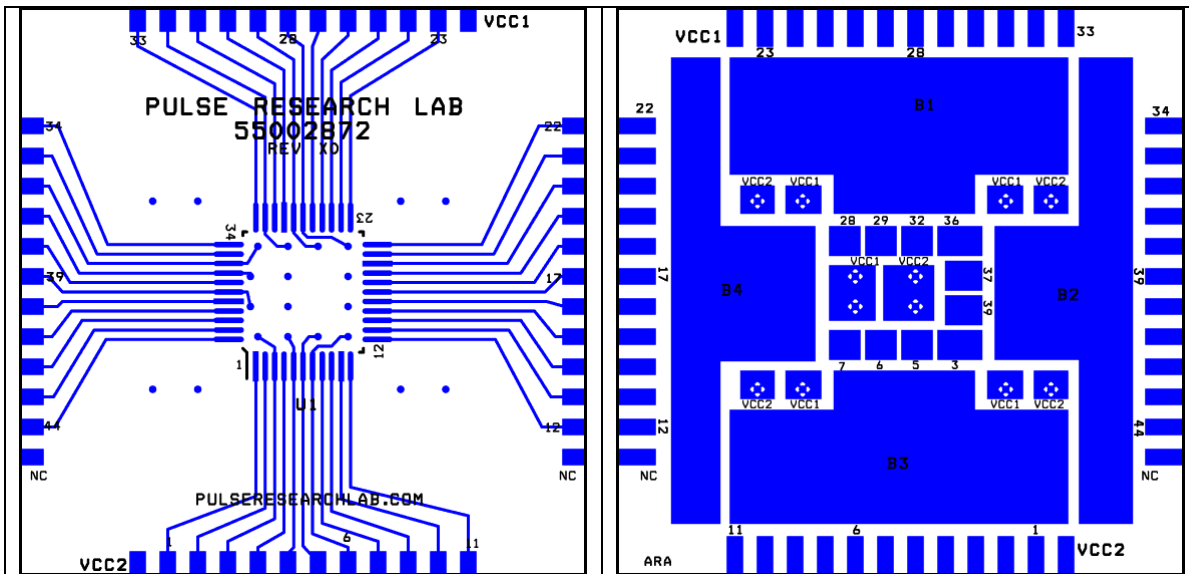
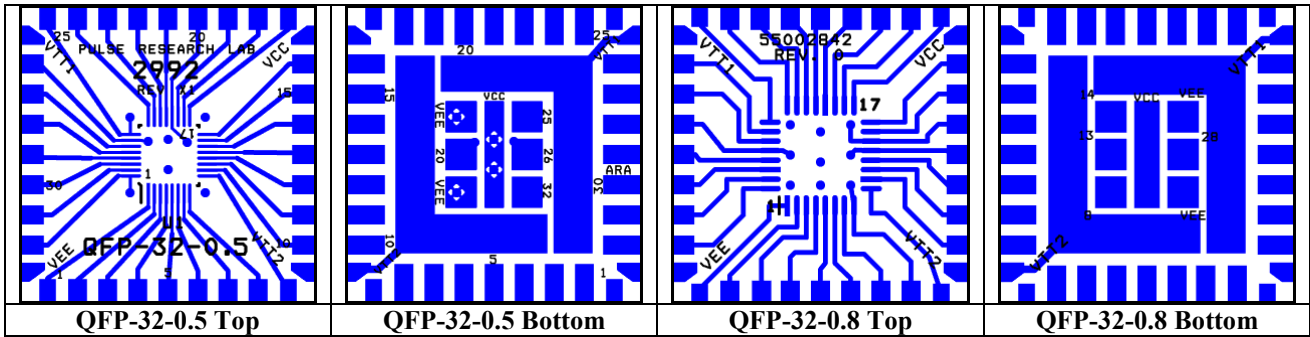

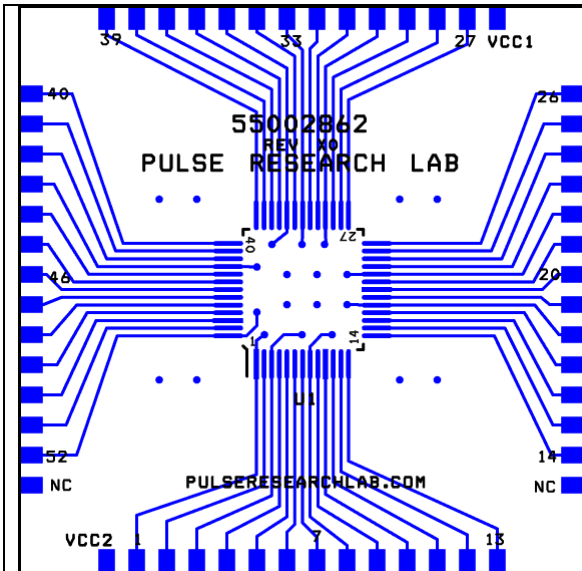

QFP-52-0.65 Top

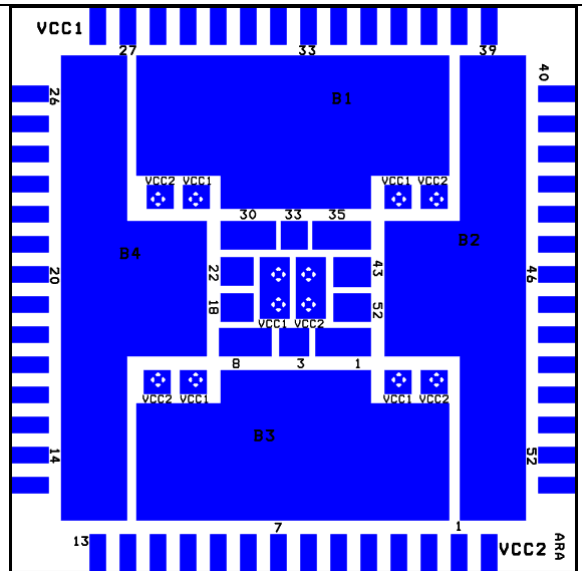

QFP-52-0.65 Bottom

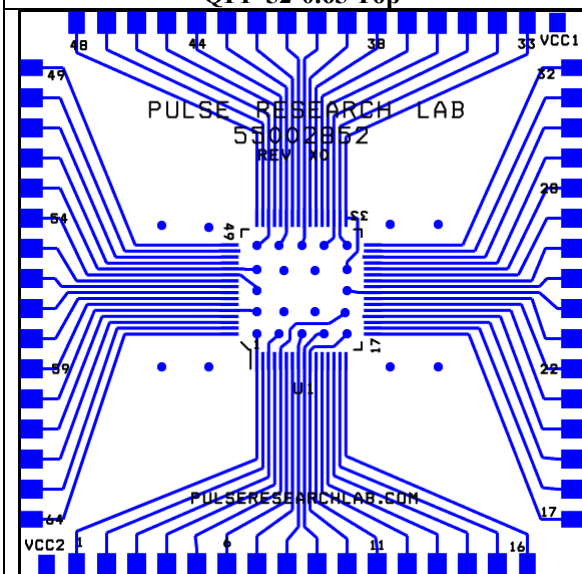

QFP-64-0.5 Top

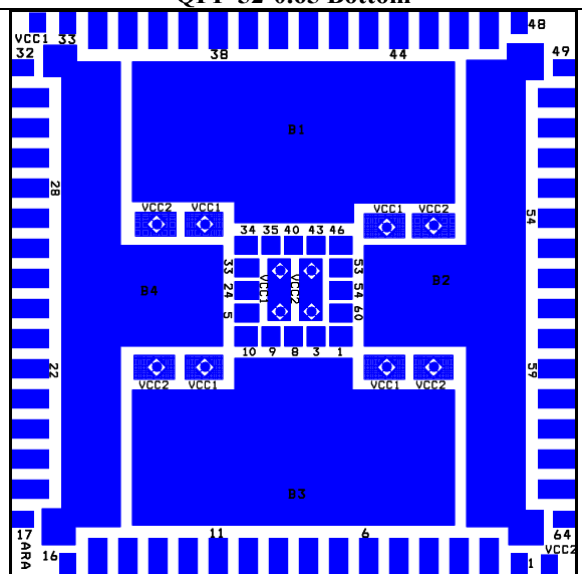

QFP-64-0.5 Bottom

Gigadapter Dimensions Table

Subject to footprint pitch and width specifications listed below, the Gigadapters will typically support the following devices:

- “SO” adapters support devices described as SO, and SOIC
- “SSO” adapters support devices described as SSO, SSOP, MSSOP, and TSSOP
- “LCC” adapters support devices described as LCC, CLCC, and PLCC
- “QFP” adapters support devices described as QFP, HLQFP, HQFP, HTQFP, HVQFP, LQFP, MQFP, TQFP, or VQFP

Model	Footprint Pitch		Footprint Width				Adapter Size			
			Min		Max		mm		in	
	mm	in	mm	in	mm	in	W	L	W	L
SO-8	1.270	0.050	2.540	0.100	7.366	0.290	12.700	15.240	0.500	0.600
SO-8RF	1.270	0.050	2.540	0.100	7.366	0.290	12.700	15.240	0.500	0.600
SO-14	1.270	0.050	2.540	0.100	7.366	0.290	12.700	22.860	0.500	0.900
SO-14RF	1.270	0.050	2.540	0.100	7.366	0.290	12.700	22.860	0.500	0.900
SO-16	1.270	0.050	2.540	0.100	7.366	0.290	12.700	25.400	0.500	1.000
SO-16RF	1.270	0.050	2.540	0.100	7.366	0.290	12.700	25.400	0.500	1.000
SO-20	1.270	0.050	6.604	0.260	11.811	0.465	25.400	30.480	1.000	1.200
SO-20RF	1.270	0.050	6.604	0.260	11.811	0.465	25.400	30.480	1.000	1.200
SSO-8	0.650	0.026	3.556	0.140	7.620	0.300	12.700	15.240	0.500	0.600
SSO-14	0.650	0.026	3.556	0.140	7.620	0.300	12.700	22.860	0.500	0.900
SSO-16	0.650	0.026	3.556	0.140	7.620	0.300	12.700	25.400	0.500	1.000
SSO-20	0.650	0.026	4.572	0.180	9.144	0.360	25.400	30.480	1.000	1.200
SSO-24	0.650	0.026	4.572	0.180	9.144	0.360	25.400	35.560	1.000	1.400
SSO-24RF	0.635	0.025	3.429	0.135	7.620	0.300	25.400	35.560	1.000	1.400
SSO-28	0.650	0.026	4.572	0.180	9.144	0.360	25.400	40.640	1.000	1.600
SSO28-RF	0.635	0.025	3.429	0.135	7.620	0.300	25.400	37.465	1.000	1.475
SSO-30	0.650	0.026	4.572	0.180	9.144	0.360	25.400	43.180	1.000	1.700
SSO-30RF	0.650	0.026	3.810	0.150	7.874	0.310	25.400	37.465	1.000	1.475
SSO-48	0.500	0.020	5.842	0.230	9.398	0.370	25.400	66.040	1.000	2.600
LCC-20	1.270	0.050	10.000	0.395			25.146	25.146	0.990	0.990
LCC-28	1.270	0.050	12.570	0.495			25.146	25.146	0.990	0.990
QFP-32-0.5	0.500	0.020	7.100	0.280			25.400	25.400	1.000	1.000
QFP-32-0.8	0.800	0.032	9.200	0.360			25.400	25.400	1.000	1.000
QFP-44-0.8	0.800	0.032	13.450	0.530			48.260	48.260	1.900	1.900
QFP-48-0.5	0.500	0.020	9.200	0.360			48.260	48.260	1.900	1.900
QFP-52-0.65	0.650	0.026	12.200	0.470			48.260	48.260	1.900	1.900
QFP-64-0.5	0.500	0.020	12.200	0.480			48.260	48.260	1.900	1.900

Accessories

These time saving accessory components are recommended for use with the Gigadapters and Gigadapter Motherboards:

Voltage Regulator SIP Module: Since every circuit requires some form of a power supply, an optimized Voltage Regulator SIP module saves time and eliminates the need for building and troubleshooting. Either insert the SIP module into the dedicated location on the motherboard and solder, or use pin sockets so that different SIP modules can be used.

AC/DC Adapter: Although any lab supply can do the job, the PRL-760A, ± 8.5 V/1.4 A, adapter can be used for most applications, and it plugs directly into the modular jack provided for each motherboard. A voltage cable is included, and no troubleshooting is required.

Pin Sockets: These low profile pin sockets enable quick and easy component changes. They accept all Gigadapters, Voltage Regulator SIP Modules and components with lead diameter of 0.02-in. The MC10EL32 frequency divider was clocked in excess of 3 GHz when tested in the GD970-3.8 motherboard using these sockets and the plug-in 50 Ω coaxial interconnect modules.

Plug-in 50 Ω Coaxial Interconnect Modules: These quick connect and disconnect modules are great time savers when compared to stripping, soldering and desoldering coaxial cables. Standard lengths are 4-in., 6-in. and 8-in.

Surface Mount Components: When breadboarding or prototyping with Gigadapters, the most commonly used components are 0.1 μ f decoupling capacitors, zero Ohm jumpers and 49.9 Ω resistors. These components, in the 0805 size, are available in bags of multiple quantities. Components with different values and sizes are also available.

ECL Terminators: These functional modules enable direct connections between ECL/PECL/LVPECL signals and ground-referenced 50 Ω input measurement instruments, such as sampling scopes and counters, etc. An AC/DC adapter is included with each ECL/PECL Terminator.