

MODEL:
Vent Kit - 6x12

VENT KIT 6x12

Universal vents for use with fire pit enclosures.
Each vent provides 18-square inches of ventilation

Installation and Operating Instructions

**IF YOU CANNOT READ OR UNDERSTAND THESE INSTALLATION INSTRUCTIONS
DO NOT ATTEMPT TO INSTALL OR OPERATE THIS APPLIANCE**



PLEASE RETAIN THIS MANUAL FOR FUTURE REFERENCE

DESCRIPTION: These vents are designed to be used with Ready to Fit (RTF) enclosures as well as universal vent for many other types of fire pit enclosures. Figure 1 shows the actual dimensions of each vent.

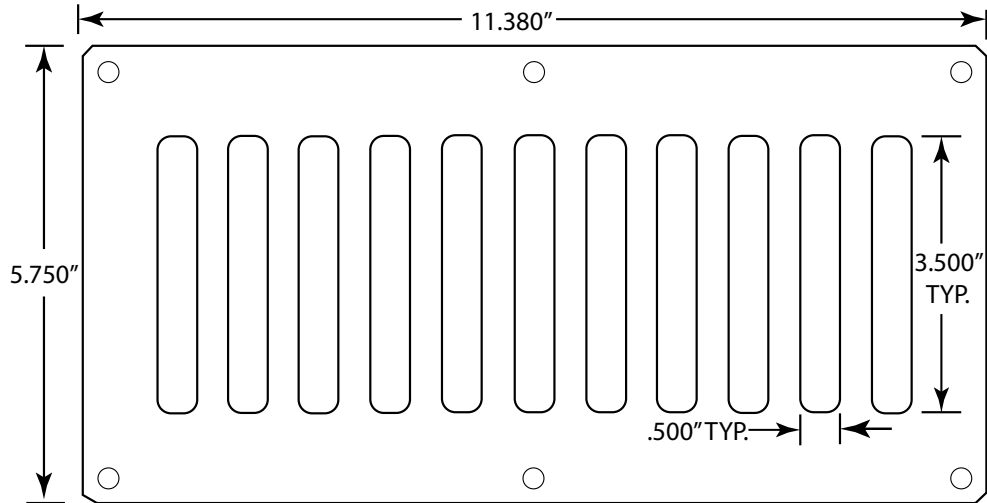

Fig. 1 Vent dimensions.

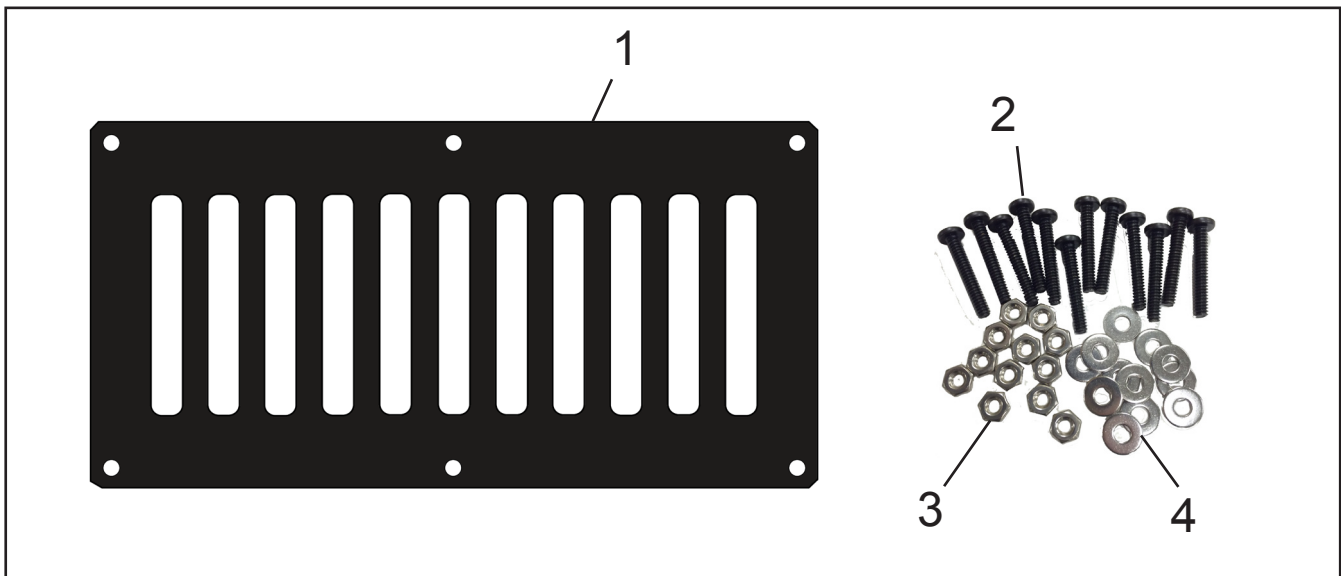

Table 1: Part Identification

Replacement Parts

Item #	Part Number	Description	Qty.
1	VENT- 6x12	6" x 12" Vent	2
2	SCREW1024PANBL	1.25" Phillips black pan head screw	12
3	ST3-113-1020	10x24 Stainless steel nut	12
4	WASHER10SS	#10 Stainless steel flat washer	12

Install the vents on opposite sides of the enclosure to ensure cross flow ventilation. Cross flow ventilation is necessary to provide free flowing air to assist in keeping the enclosure dry and cool during operation of a fire pit.

Cut an rectangular opening 9.75" x 3.75" into on opposite sides of the enclosure. Center the vent over the cut out area ensuring the vent slots are clear of any obstruction. Mark the holes with a pencil or marker. Drill six 1/4" clearance holes, place the vent centered over the opening, insert a screw into the vent and enclosure at the same time and secure with washer and nut on the inside. Repeat the process until all six screws are securing each vent into place on both sides of the enclosure.

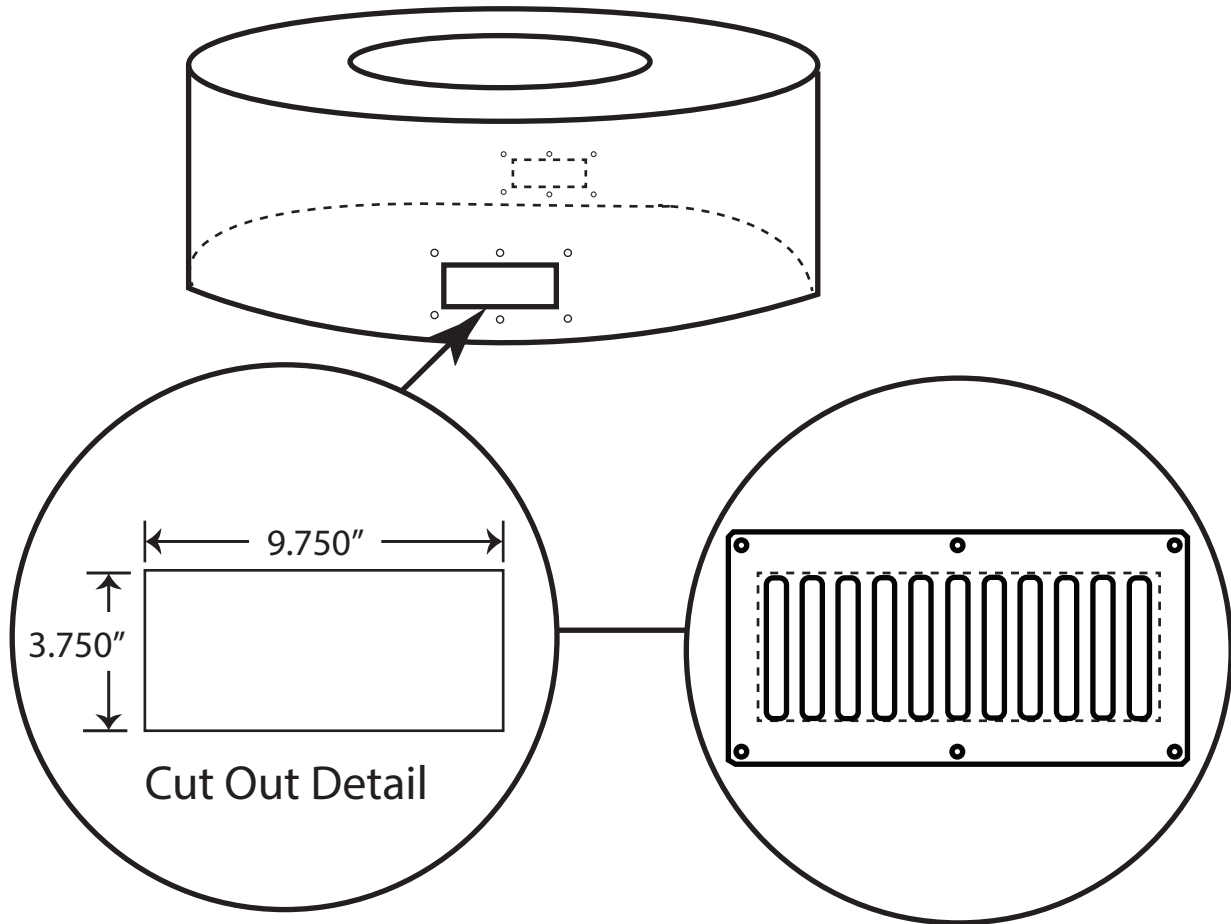

Fig. 2 Cutting hole in enclosure and installing vent.

FOR TECHNICAL SERVICE, CALL: (855) 498-8324

Firegear Outdoors
9230 Conservation Way
Fort Wayne, IN 46809
For Sales: (888) 672-8929

WEB SITE: www.firegearoutdoors.com

