

NOTE: Manual key valve shown above in mounting plate is for illustration purposes only. The manual key valve does not come with this kit but is provided with a match light fire pit system.

MODEL: MSI-BSMTI

Manual Spark Ignition (MSI) Kit

For Use only with Matchlight (MT) UL Approved Fire Pit Pans with Burning Spur

Installation and Operating Instructions

**IF YOU CANNOT READ OR UNDERSTAND THESE INSTALLATION INSTRUCTIONS
DO NOT ATTEMPT TO INSTALL OR OPERATE THIS APPLIANCE**



Warning: For Outdoor Use Only



PLEASE RETAIN THIS MANUAL FOR FUTURE REFERENCE

PRODUCT DESCRIPTION: This Manual Spark Ignition (MSI) kit is designed to be installed with a UL approved Firegear Outdoors Match Light fire only. It comes partially assembled and uses a AAA battery inside the ignitor module and push button to light a fire pit burner with spark ignition. The MSI Mounting plate is intended to be installed into cement board or used with a paver kit (See separate instruction for Paver Kit).

IMPORTANT NOTICE: Before using this MSI kit ensure you are using a Firegear UL approved fire pit pan with a spur burner. See Figure #1.

When looking at the pan from a top view (see arrows) the rectangular ignitor hole MUST be at the bottom of the spur burner leg, not the top. IF NOT, DO NOT USE! THIS KIT WILL NOT WORK WITH YOUR FIRE PIT!

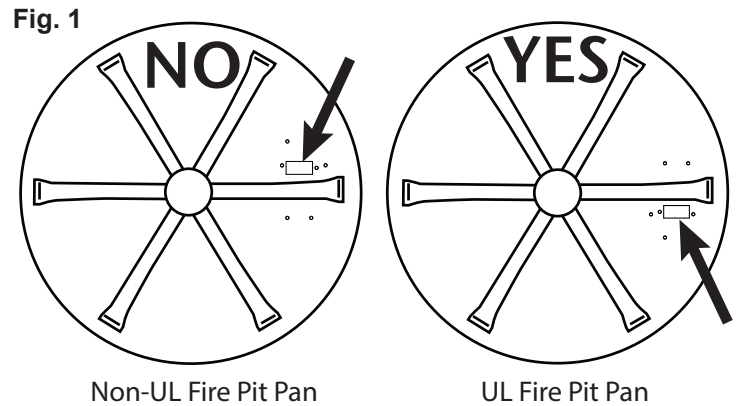

Non-UL Fire Pit Pan

UL Fire Pit Pan

PREPARING THE FIRE PIT BURNER PAN FOR THE 2-PROBE SPARK IGNITOR

If the fire pit is already installed then remove all media before beginning installation and turn OFF gas supply.

Step #1 Prepare the fire pit pan by first removing the two screws from the 1" x 2" metal cover plate exposing the rectangular hole then align the burner leg as shown in Fig. 2. The inside edge of the burner leg should be approximately 3/4-inch away from the inside edge of rectangular hole. See Fig. 1.

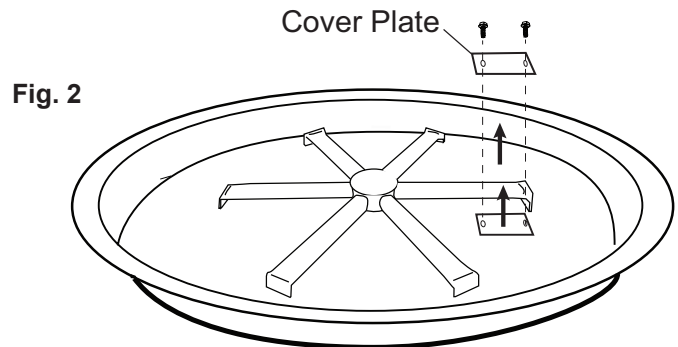

Fig. 2

Step #2 Remove the two stainless steel nuts from the probe assembly but leave it assembled, then carefully slide the orange and black wires from the top of the pan through square hole in the fire pit pan resting over the burner leg and install the screws through the existing holes of the cover plate. See Fig. 3.

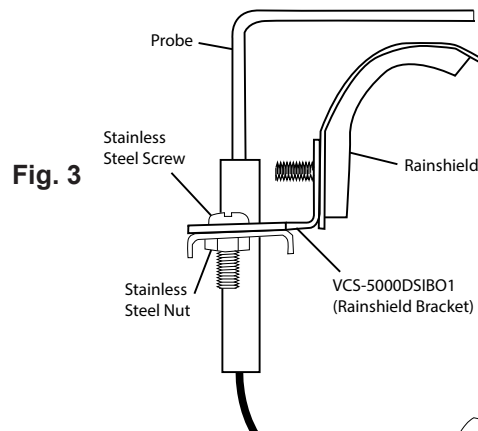

Fig. 3

Step #3 Insert the two stainless steel screws from the probe assembly through the existing cover plate holes attach the two nuts previously removed and secure into place. Ensure the assembly sits flat against the fire pit pan. See Fig. 4

CAUTION: Ensure the probes are not touching the rainshield or the piezo will not spark at the tip of the probes. If necessary you can adjust the rainshield by loosening the screw inside the rainshield bracket, pushing it down and retightening the screw. Fig. 3 shows proper spacing of probe to rainshield.

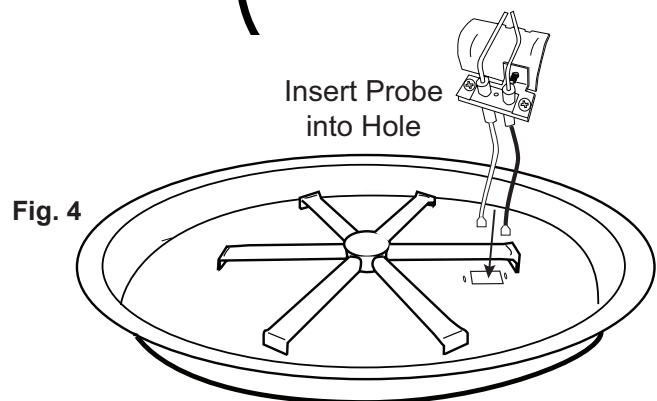
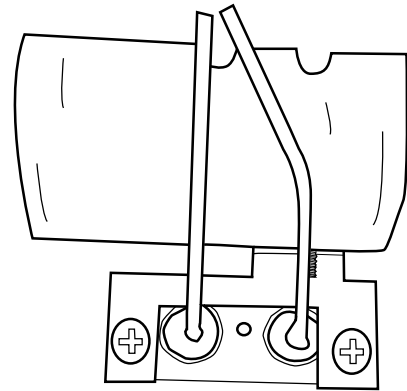

Fig. 4

NOTE: Ensure the probes are aligned ovetop of the rainshield notched/cutout area and are spaced approximately 1/8-inch apart from the end/tips, above the burner leg. See **Fig. 5**.

Fig. 5



Step #5 The mounting plate has two holes in which to install the Piezo module and the manual key valve. To install the Piezo module use the smaller hole with the two notches and slide module into the plate until it stops. Using the plastic nut thread it onto the Piezo module to secure into place. Careful not to turn the nut too tight and crack the plastic. Install the AAA battery as shown and thread the red button cap on the remaining threads of the module. See **Fig. 6**

Fig. 6

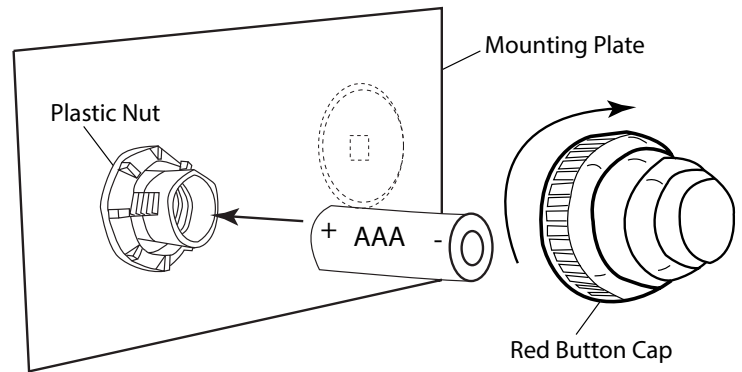

Step #6 The manual key valve is designed to be installed into the larger hole of the mounting plate by placing the valve against the protruding bracket and rotating the chrome flange clockwise until tight against the plate to secure it into place as shown in Fig. 7

Fig. 7

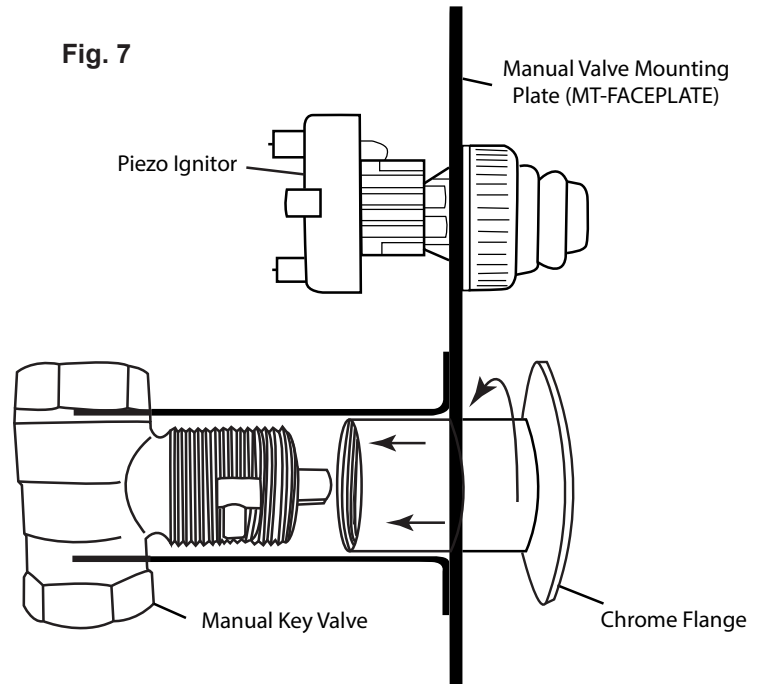

Step #7 Install the ignition hood over top of the ignition probe assembly into the existing prepunched holes of the burner pan by using the five #10 - 24 x 1/2" provided screws. See **Fig. 8**.

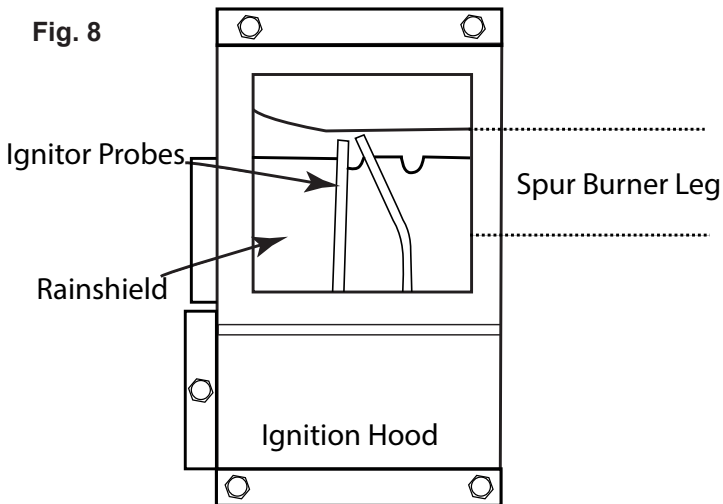

Step #8: Install the mounting plate within 40-inches of the 2-probe Piezo ignitor. This will allow enough "play" in the wires to make your connections.

The mounting plate can be installed using the template on the back page of this manual. See **Fig. 9** for details of using template in concrete board and follow template instructions on back page of this manual.

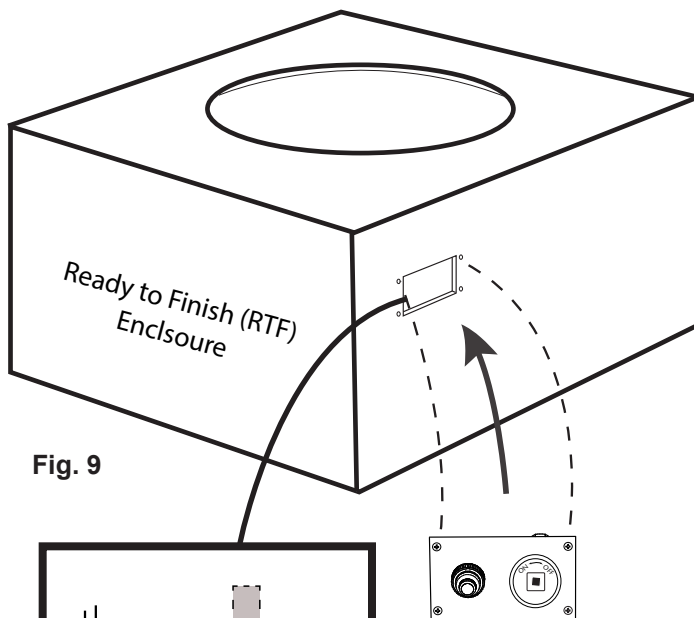
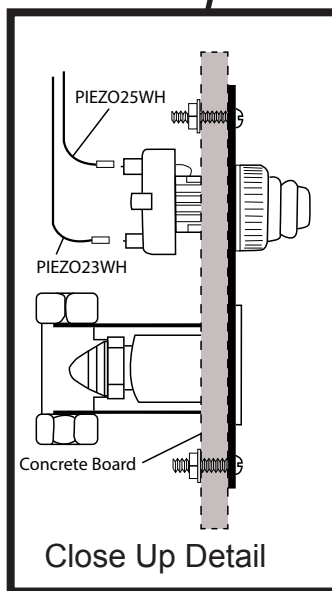

Fig. 9

Step #9: Connect the 3/16-inch extension wires into the back side of the spark ignitor module. See **Fig. 9** detail.

Step #10: Attach the 1/4" extension wires (PIEZO23WH & PIEZO25WH) to either of the ignition probe orange and black spark ignitor wires. See **Fig. 10**.



Step #11: Test the ignitor by pushing and holding the red button to ensure the 2-probe ignitor is sparking inside the ignition box in the burner pan. The spark should be located directly overtop of the burner port hole for proper ignition of the gas as previously discussed. Spacing between the probes should be approximately 1/8" for proper spark. **See Fig. 5** if necessary.

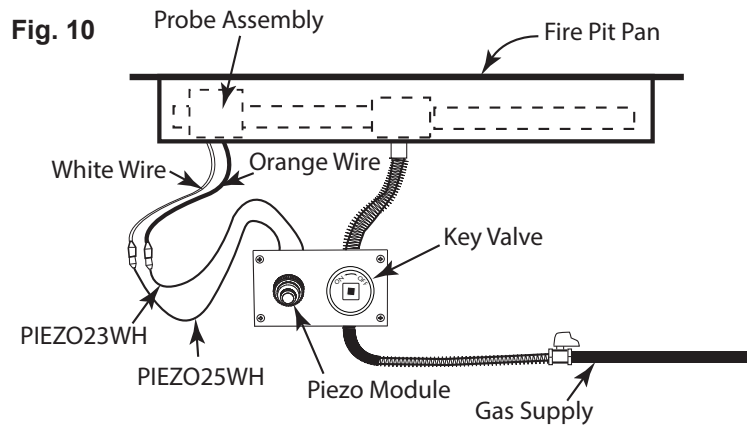

Step #12: . Install the ignition hood screen mesh and ensure no media covers hood. See Fig. 11. Install the lava rock/media material according to fire pit install manual and turn the main gas supply back ON. Installation is now complete.

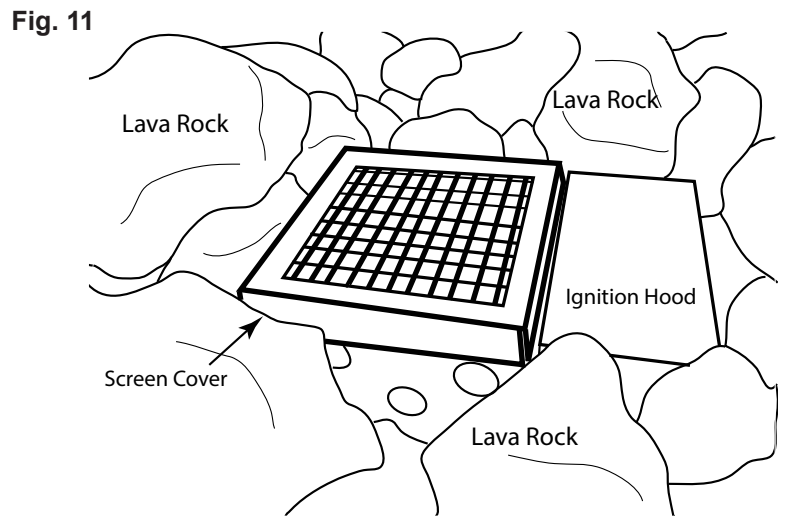

LIGHTING INSTRUCTIONS

READ ALL LIGHTING INSTRUCTIONS BEFORE ATTEMPTING TO LIGHT FIRE PIT

CAUTION: ENSURE YOU HAVE LEAK TESTED THE FIRE PIT BEFORE OPERATING.

WARNING: Do not stand over fire pit during ignition or operation due to high surface temperatures.

1. Push and hold the red button on the manual Piezo ignitor and ensure sparking is occurring at the probes inside fire pit.
2. At the same time turn **ON** gas supply.
3. Gas should ignite within 10 seconds or less. If fire pit does not light within 10 seconds turn **OFF** the gas supply. Check ignitor probe location (Figures 5 & 8), ensure there is an 1/8" gap between the probes with a good strong spark then repeat steps 2 through 4.
4. Turn gas supply OFF to check probes and battery if fire pit does not light.

LIMITED WARRANTY

Firegear Outdoors warrants the MSI-BSMTI for 12 months from date of purchase or installation to original purchaser to be free from defects in materials and workmanship. Damage to the MSI-BSMTI caused by accident, misuse, abuse, or installation error, whether performed by a contractor, service company, or owner, is not covered by this warranty.

Firegear Outdoors will not be responsible for labor charges and/or damage incurred in installation, repair, replacement, or for incidental or consequential damage. Some states, provinces, and nations do not allow exclusion or limitations of incidental or consequential damages, so the above limitations or exclusions may not apply. This warranty gives you specific legal rights. You may also have other rights that vary by state, province, or nation.

REPLACEMENT PARTS

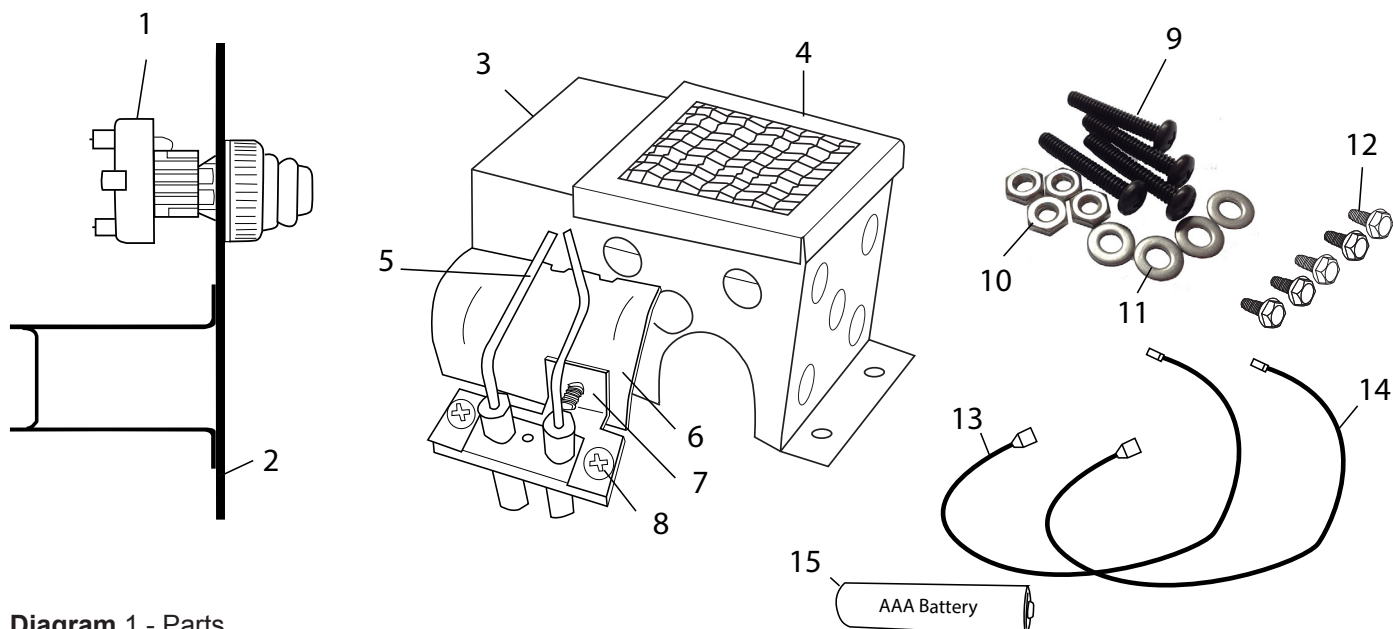

Diagram 1 - Parts

#	Description & Part Number	#	Description & Part Number
1	(1) Manual Spark Ignitor Module (3042-RB)	8a	(2) 10x24 nut with item #7 (not shown) ST3-113-1020)
2	(1) Mounting plate (MT-FACEPLATE)	9	(4) #10-24x1.25" Black Phillips Screw (SCREW1024PANBL)
3	(1) Ignition Hood (SPURHOOD)	10	(4) #10-24 Stainless Nut (ST3-113-1020)
4	(1) Ignition Hood Screen (ST3-100-1027)	11	(4) #10 Stainless Flat Washer (WASHER10SS)
5	(1) 2-Probe Manual Spark Ignitor (AF-5000DSI2P03)	12	(5) #10-24x½" Stainless Steel Screws (ST3-113-1028)
6	(1) Burner rainshield (RAINSHIELD)	13	(1) Extension wire - not shown (PIEZO23WH)
7	(1) Rainshield bracket (VCS-5000DSIB01)	14	(1) Extension wire -not shown (PIEZO25WH)
8	(2) 10x24 Pan head screw with item #7 (ST3-113-1019)	15	(1) AAA Battery (BATTAAA)

FOR TECHNICAL SERVICE CONTACT:

(855) 498-8324

Firegear Outdoors
9230 Conservation Way
Fort Wayne, IN 46809
(888) 672-8929

Web Site: www.firegearoutdoors.com

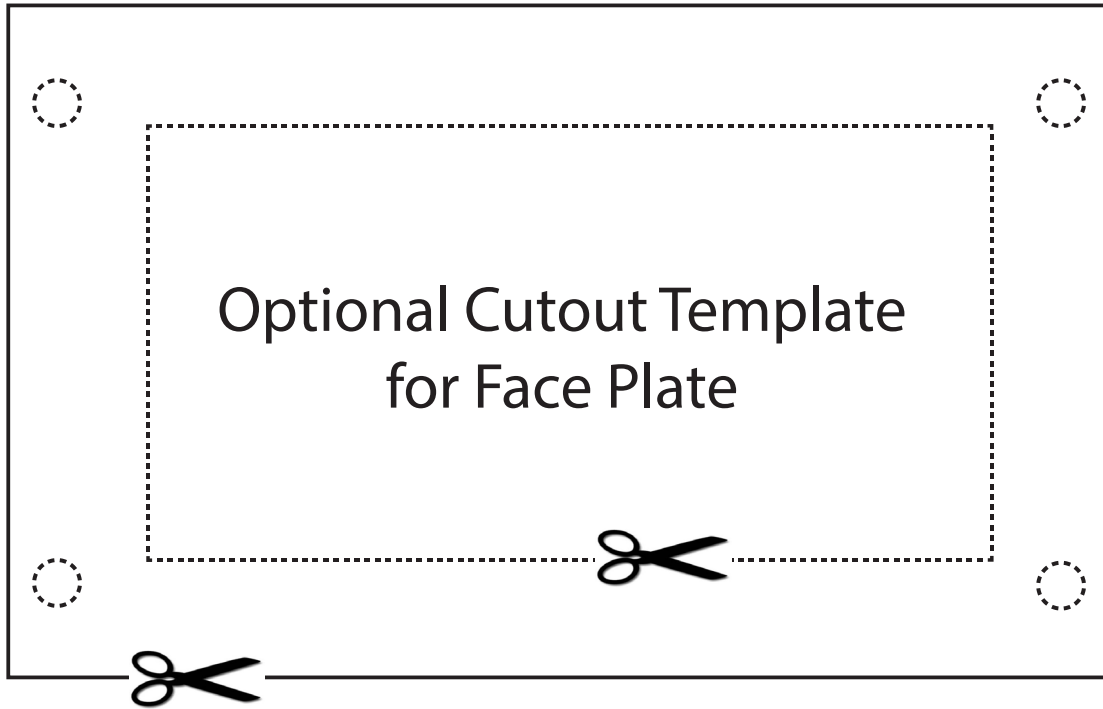

This instruction provides an option to mount the face plate to concrete board. Use the template above to complete the installation.

The face plate can be mounted vertically or horizontally.

Using scissors carefully cutout the template and trace it on your concrete board. The dotted line provides the cutout area to mount face plate. Use a concrete drill bit to drill (4) 3/16" diameter holes. Install the 1¼" black oxide screws through the front of the faceplate with the nuts and washers on the backside. These are all provided in the hardware bag.

CAUTION: Careful not to over-tighten screws and nuts to ensure the cement board does not crack or break.