

**GAS CONVERSION KIT FOR FIREPLACES WITH ELECTRONIC IGNITION  
NATURAL GAS TO PROPANE GAS (ECOFLOW VALVE)**

[FOR USE IN FIREPLACE MODELS LISTED IN TABLE 1]

**KIT COMPONENTS**

Main Burner Orifice, Low-Rate Orifice, Conversion Sticker and Conversion Sticker Form (to be filled out and affixed by installer), Air Shutter (40" & 45" Gemini-C models only), and Installation Instructions.

Gas Conversion Kits, Natural Gas (NG) to Propane Gas (LP)		
Cat. No.	Model	Ecoflow Electronic Model Fireplaces
F3817	GCKGC35ENP	Gemini35-C, ScorpioCD35-C
F3818	GCKGC40ENP	Gemini40-C, ScorpioCD40-C
F3819	GCKGC45ENP	Gemini45-C, ScorpioCD45-C

*Table 1*

**REQUIRED TOOLS AND SUPPLIES**

Safety Gloves, Adjustable Wrench, Channel Locks, Flat Blade Screwdriver, 4mm Allen Wrench (*for some pilot assemblies - see Figure 6*), 5/16" Nutdriver, Pipe Joint Compound, or Teflon Tape

**TURN OFF THE GAS SUPPLY TO THE APPLIANCE. DISCONNECT ELECTRICAL POWER SUPPLY.**

**READ ALL THE STEPS BEFORE STARTING THE CONVERSION. INSTALLER NOTICE: THESE INSTRUCTIONS MUST BE LEFT WITH THE APPLIANCE.**

When installing gas components use pipe joint compound or Teflon tape on all pipe fittings before installing (Do not use pipe joint compounds on flare fittings).

**NOTE: THE FIREPLACE MUST BE OFF AND COLD BEFORE PERFORMING THE GAS CONVERSION.**

**ALL WARNINGS, PRECAUTIONS AND INSTRUCTIONS IN THE INSTALLATION AND OPERATION MANUAL PROVIDED WITH THE APPLIANCE APPLY TO THESE INSTRUCTIONS.**

**GENERAL INFORMATION**

Gas conversion kits are available to adapt the fireplace from the use of one type of gas to the use of another. These kits contain all the necessary components needed to complete the task including labeling that must be affixed to ensure safe operation.

**! IMPORTANT CANADA**

The conversion shall be carried out in accordance with the requirements of the provincial authorities having jurisdiction and in accordance with the requirements of the CAN/CSA B149.1 Installation code.

**! IMPORTANT LE CANADA SEULEMENT**

La conversion devra être effectuée conformément aux recommandations des autorités provinciales ayant juridiction et conformément aux exigences du code d'installation CAN/CSA B149.1.

**! WARNING**

This conversion kit shall be installed by a qualified service agency in accordance with the manufacturer's instructions and all applicable codes and requirements of the authority having jurisdiction. If the information in these instructions is not followed exactly, a fire, explosion or production of carbon monoxide may result causing property damage, personal injury or loss of life. The qualified service agency performing this installation is responsible for the proper installation of this kit and assumes responsibility for this conversion. The installation is not proper and complete until the operation of the converted appliance is checked as specified in the manufacturers instructions supplied with the kit. The qualified service agency performing this installation assumes responsibility for this conversion.

**! AVERTISSEMENT**

Cet équipement de conversion sera installé par une agence qualifiée de service conformément aux instructions du fabricant et toutes exigences et codes applicables de l'autorisés avoir la juridiction. Si l'information dans cette instruction n'est pas suivie exactement, un feu, explosion ou production de protoxyde de carbone peut résulter le dommages causer de propriété, perte ou blessure personnelle de vie. L'agence qualifiée de service est esponsable de l'installation propre de cet équipement. L'installation n'est pas propre et complète jusqu'à l'opération de l'appareil converti est chèque suivant les critères établis dans les instructions de propriétaire provisionnées avec l'équipement.

## **! IMPORTANT**

The burner orifice provided in this kit are only for use at elevations of 0 to 2,000 feet (610 M) in the USA and 0 to 4,500 feet (0-1372 M) in Canada. At higher elevations the BTU input must be de-rated by 4% for every 1,000 feet (305 M) to maintain the proper ratio of gas to air. If the installer must convert the unit to adjust for varying altitudes, a deration information sticker must be filled out by the installer and adhered to the appliance at the time of the conversion. Contact your local gas supplier for deration requirements for your area.

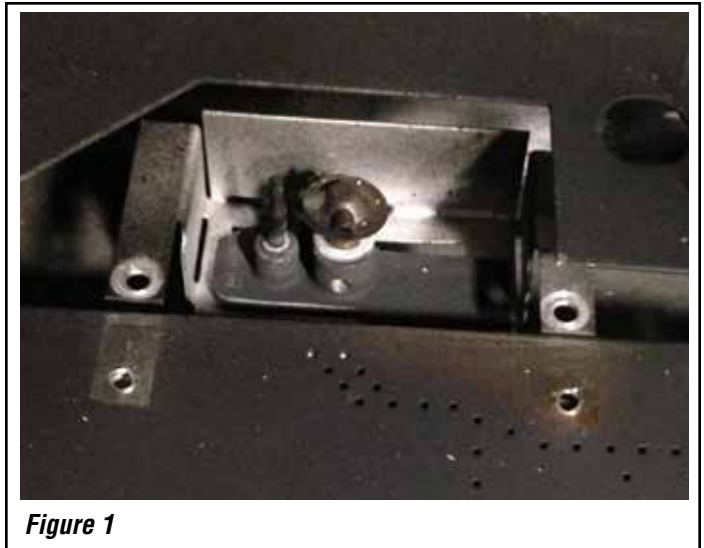

Figure 1

## INSTALLING GAS CONVERSION KITS

### **! CAUTION**

The gas supply shall be shut OFF prior to disconnecting the electrical power, before proceeding with the conversion.

### **! ATTENTION**

Avant d'effectuer la conversion, coupez d'abord l'alimentation en gaz, ensuite, coupez l'alimentation électrique.

1. **TURN OFF THE GAS SUPPLY TO THE FIREPLACE** and disconnect power supply at the circuit breaker. Ensure fireplace is cold.
2. Remove the facade and glass door per instruction in the Installation and Operation Manual.
3. Remove the logs per instruction in the Installation and Operation Manual. **Exercise care so as not to break the logs.**
4. Perform the following conversion instructions:

## GAS CONVERSION INSTRUCTIONS

**IMPORTANT NOTE:** When installing gas components use pipe joint compound or Teflon tape on all pipe fittings before installing (ensure propane resistant compounds are used, do not use pipe joint compounds on flare fittings).

**Step 1.** Remove pilot bracket from burner, before removing the burner, by removing two screws (see *Figure 1*).

**Step 2.** Remove Burner assembly and replace the main burner orifice supplied in this kit. Refer to *Table 5 on Page 5* for verification of proper main burner orifice size supplied in kit.

**Step 3.** Remove the low-rate orifice from the valve and replace with the low rate orifice supplied in kit. See *Figure 3*.

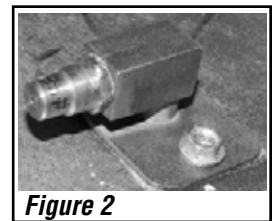

Figure 2

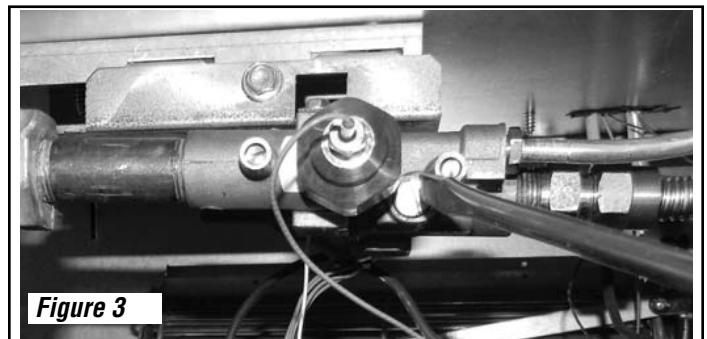

Figure 3

**Step 4.** Remove the regulator set plug by using a flat head screwdriver. See *Figure 4*.



Figure 4

**Step 4A.** Change the Stem Position on the Plug. See *Figures 4A and 4B*.

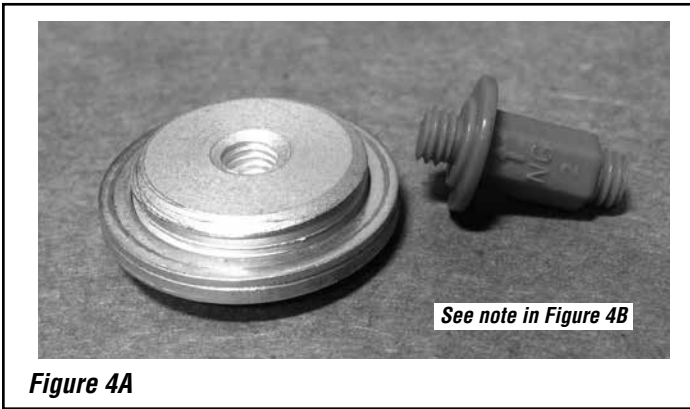

**Figure 4A**

**Step 4B.** *Figure 4B* shows the stem plug positioning for Propane Gas (LP).

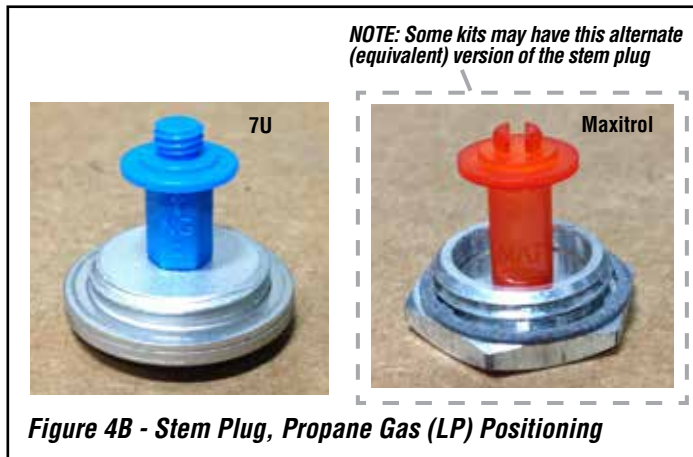

**Figure 4B - Stem Plug, Propane Gas (LP) Positioning**

**Step 5.** Pull the pilot hood straight up to remove and expose the pilot orifice.

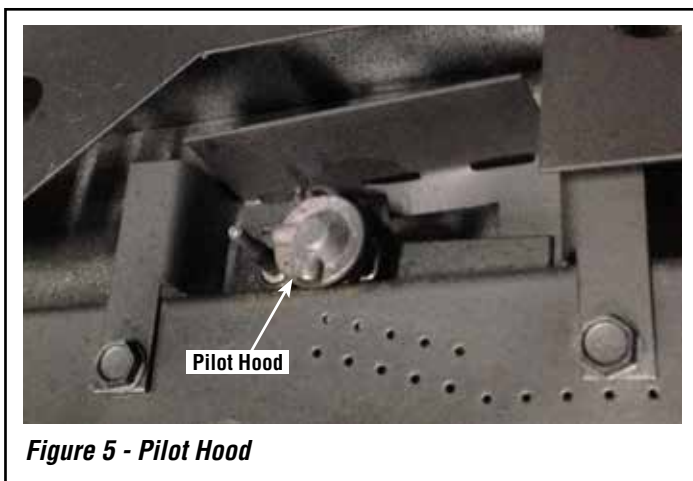

**Figure 5 - Pilot Hood**

**Step 6.** For propane gas (LP), turn the pilot orifice clockwise until it stops. See *Figure 6*.

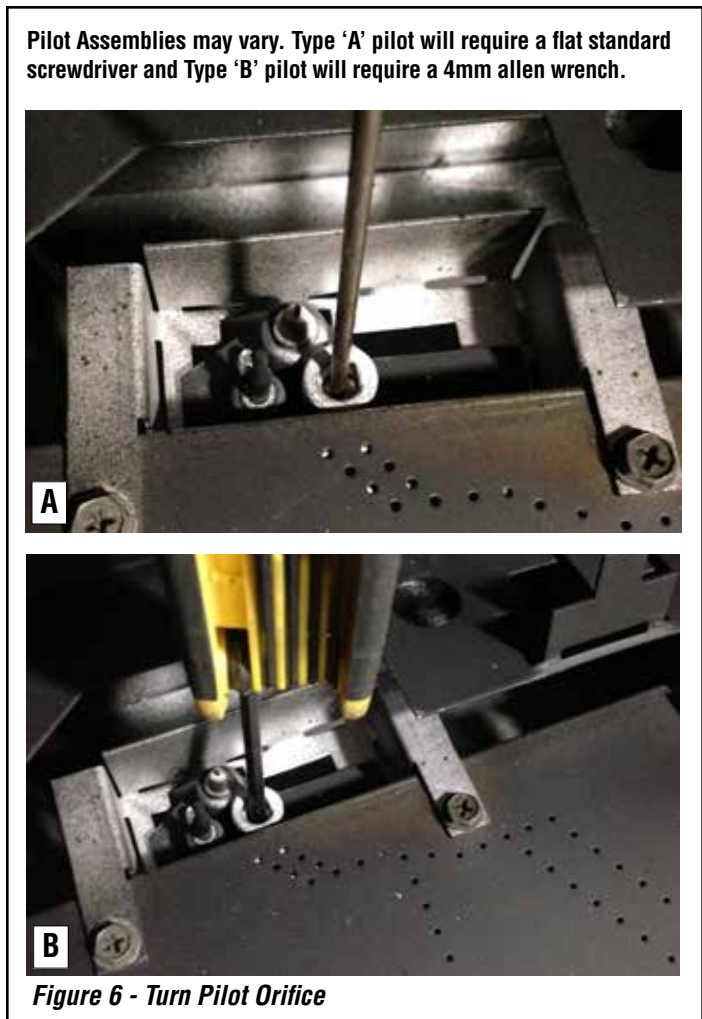

**A**

**B**

**Figure 6 - Turn Pilot Orifice**

**Step 7.** Reinstall pilot hood by pressing down firmly until a click is heard. See *Figure 5*.

**Step 8. 40" & 45" Gemini-C models ONLY.** Remove the air shutter adjustment screw (*Figure 7*) and remove the air shutter (1/4" nut driver/ socket) from burner. Use air shutter rod from removed air shutter and place on new shutter provided in this kit. Install new shutter assembly on burner. Discard the removed air shutter.

**Step 9.** Retrieve the burner and hold the venturi tube above the orifice. Place the shutter adjusting rod in the slot of the shutter arm (*Figure 7*). Set the burner assembly into its position and secure using two screws.

**Step 10.** Reinstall the burner baffle and pilot bracket using 5 flat tipped screws (in burner) and two pointed screws.

**Step 11.** Reinstall the log set. See log set installation in the *Installation and Operation Manual*.

**Step 12.** Reinstall the glass door and the facade.

**Step 13. Turn on gas supply and test for gas leaks, using a gas leak test solution—also known as bubble leak solution.**

*NOTE: Using a soapy water solution is an effective leak test solution but it is not recommended, because the soap residue that is left on the pipes/ fittings can result in corrosion over time.*

- A. Light the fireplace (refer to the lighting instructions label in the control compartment).
- B. Brush all joints and connections with the gas leak test solution to check for leaks. If bubbles are formed, or gas odor is detected, turn off the appliance. Either tighten or refasten the leaking connection, and then retest as described above.
- C. When the gas lines are tested and leak free, rinse off the leak testing solution.

**! WARNING**

**Never use an open flame to check for leaks.**

**Step 14.** Adjust the burner air shutter per instructions in the Installation and Operation manuals and **Table 2 and Figures 7 and 8.**

**CAUTION:** The air shutter should never be set so as to make the tips of the flames sooty or create sooting on the viewing glass, logs, or media. If soot begins to form after burning, the air shutter should be opened gradually until the sooting condition stops. Gas quality and gas pressure may vary, which can affect the burning characteristics of the appliance.

**BURNER AIR SHUTTER ADJUSTMENT INSTRUCTIONS**

1. Adjust the air shutters per instructions in **Figure 7** and **Table 2.**
2. Light the fireplace. Follow the lighting procedure on the lighting label in the control compartment.
3. Allow the burner to operate for at least fifteen (15) minutes while observing the flame continuously to ensure that the proper flame appearance is achieved (**Figure 8**). If the following conditions are present, adjust accordingly.
  - If flame appears sooty, adjust the air shutter, incrementally, to a more open position until the proper flame appearance is achieved.
  - If flame remains blue, adjust the air shutter, incrementally, to a more closed position until the proper flame appearance is achieved.
4. When satisfied that the burner flame appearance is normal, reinstall the facade, then proceed to finish the installation.

Models	Propane Gas
All	1/2" (12.7 mm)

**NOTE:** When rear venting or running fireplace for an extended period of time the shutter should be moved to a more open position by pulling rod down (especially on LP gas)

**Table 2 - Main Burner Shutter Opening - Factory Setting**

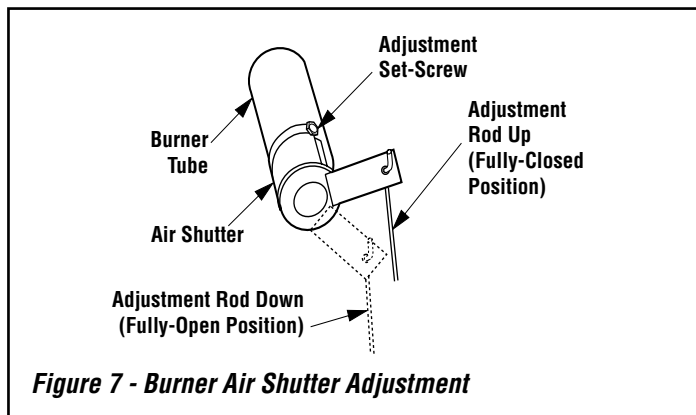

**Figure 7 - Burner Air Shutter Adjustment**

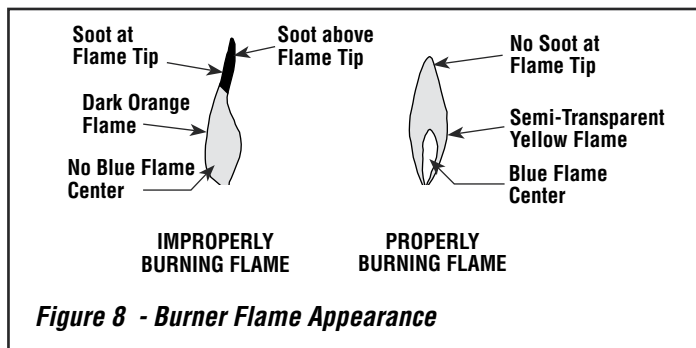

**Figure 8 - Burner Flame Appearance**

**Step 15.** Relight the main burner. The lighting instructions can be found on the lighting label in the control compartment. Verify proper burner ignition and operation (**Figure 7**).

Inspect the pilot system for proper flame. The pilot should have two flames: one that engulfs the thermocouple and one that lights the main burner (**Figure 9**).

Using a manometer, test the inlet and manifold gas pressures (**Tables 3-4, Page 5**). The inlet pressure is tested at elbow fitting removable plug and the outlet pressure is tested at gas valve outlet test port (see **Figures 13 and 14 on Page 6**).

Always test pressures with the valve regulator control at the highest setting.

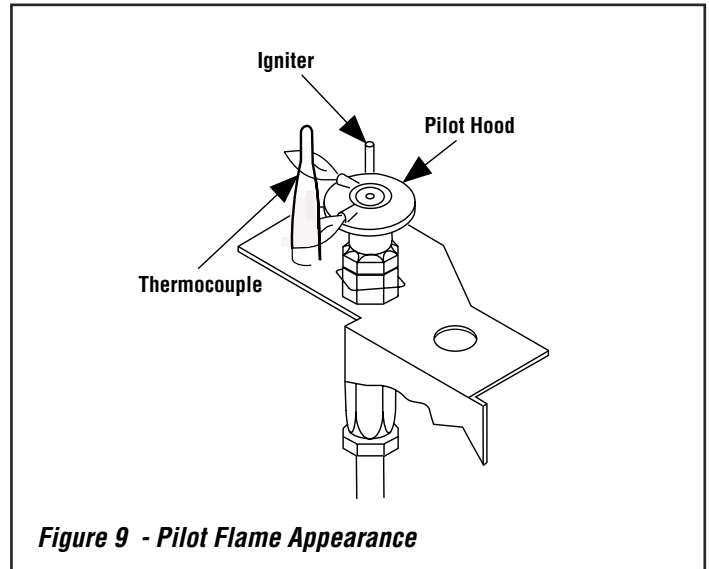

**Figure 9 - Pilot Flame Appearance**

**Step 16.** Ensure the proper relationship of the pilot to the main burner as shown in **Figure 10**.

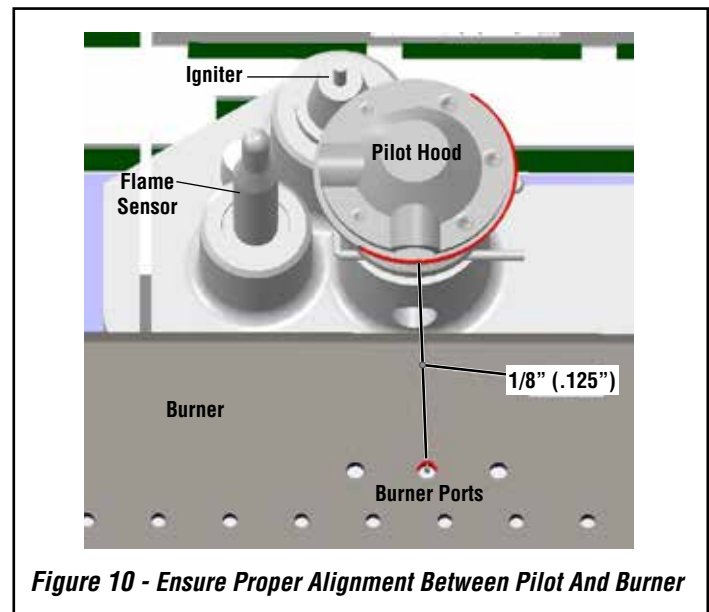

**Figure 10 - Ensure Proper Alignment Between Pilot And Burner**

**Step 17.** Affix the supplied gas conversion sticker next to the rating plate label stating this unit has been converted to propane gas. See **Figure 11**.

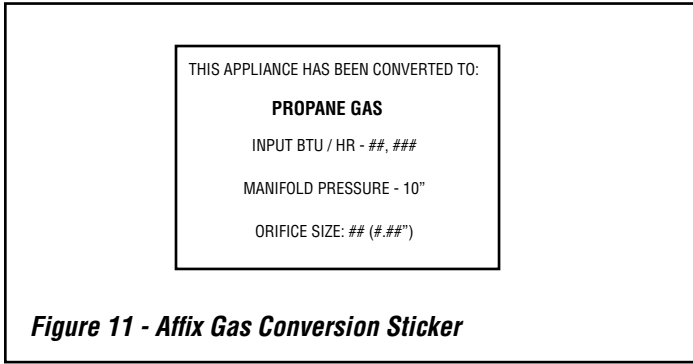

**REFERENCE INFORMATION**

Inlet Gas Supply Pressure		
Fuel #	Minimum	Maximum
Propane	11.0" WC (2.74 kPa)	13.0" WC (3.23 kPa)

**Table 3**

Manifold Gas Supply Pressure	
Fuel #	Pressure
Propane	10.0" WC / (2.49 kPa)

**Table 4**

**Step 18.** Fill out, then affix the supplied gas conversion form sticker next to the rating plate. See **Figure 12**.

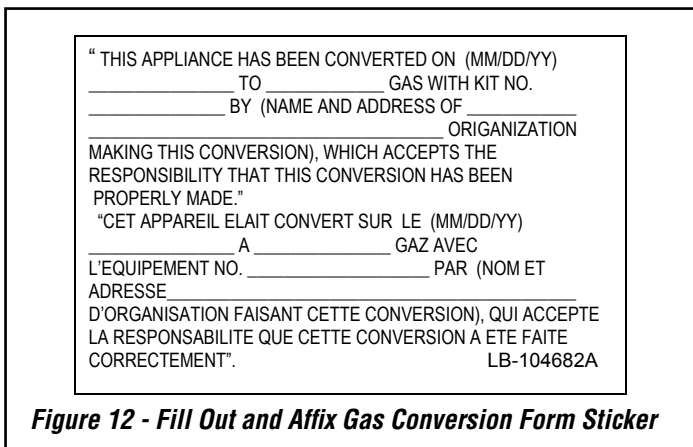

Orifice Sizes (Drill Size)	
Models	Propane - drill size
Gemini35-C, ScorpioCD35-C	99K78 (0.048")
Gemini40-C, ScorpioCD40-C	#54, 99K79 (0.055")
Gemini45-C, ScorpioCD45-C	#53, 39L10 (0.0595")

**Table 5**

**Step 19.** Reinstall the facade that included the barrier.

**NOTE: A BARRIER DESIGNED TO REDUCE THE RISK OF BURNS FROM HOT VIEWING GLASS SHALL BE USED DURING OPERATION OF THIS FIREPLACE FOR THE PROTECTION OF CHILDREN AND OTHER AT-RISK INDIVIDUALS.**

BTU/Hr Input		
Models	Propane Gas	
	High Rate	Low Rate
Gemini35-C	17,000	11,000
Gemini40-C	24,000	18,000
Gemini45-C	26,000	20,000
ScorpioCD35DEP-C	18,000	13,000
ScorpioCD40DEP-C	23,000	18,000
ScorpioCD45DEP-C	27,000	20,000

**Table 6**

## REFERENCE INFORMATION (continued)

### Gas Pressure Test Points

The outlet **manifold** test gauge connection is provided on the valve stem (see **Figure 13**). The inlet line gas pressure test point is shown in **Figure 14**. The control valves have a 3/8" (10 mm) NPT thread inlet and outlet side of the valve.

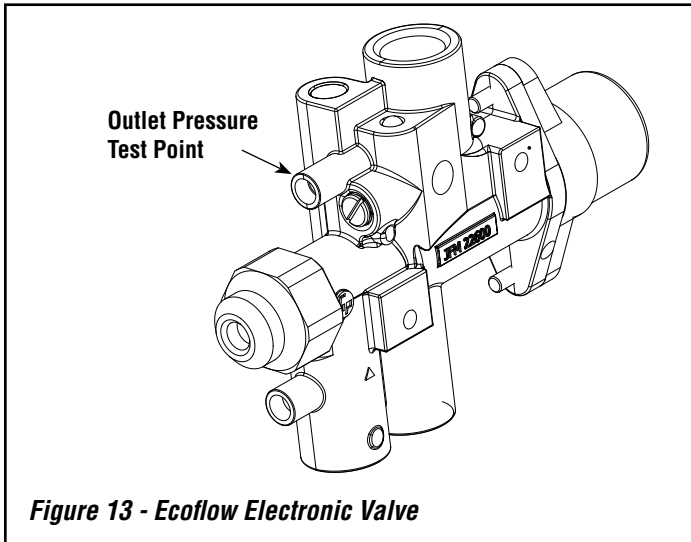

### Testing Inlet Gas Pressure (Qualified Technicians Only):

1. Turn off gas shutoff valve and electrical.
2. Remove 1/8" plug (shown in diagram below).
3. Install an 1/8" nipple in place of plug.
4. Connect manometer to nipple, using an 1/8" NPT air hose nipple/fitting.
5. Turn on shutoff valve and check for proper inlet gas pressure.
6. Reverse steps 1-5.

Some parts have been removed for clarity

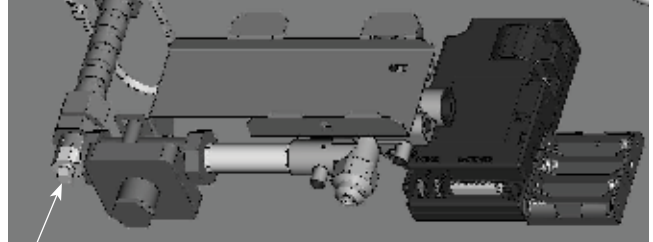

1/8" Inlet gas pressure 'test point' plug (in control compartment)

**Figure 14 - Ecoflow Inlet Gas Pressure Test Point**

Innovative Hearth Products (IHP) reserves the right to make changes at any time, without notice, in design, materials, specifications, prices and also to discontinue colors, styles and products. Consult your local distributor for fireplace code information.