

HEAT-ZONE®-WD WOOD AIR DUCT KIT

Part No: HEAT-ZONE-WD

APPROVALS

The Heat-Zone®-WD wood air duct kit is approved to use on EPA Fireplace Pioneer-III.

INTRODUCTION

The Heat-Zone®-WD wood accessory kit conveys warm air from the fireplace through air duct(s) to remote locations in the same room or other rooms of the building. See Figure 1. One or two Heat-Zone kits can be installed on the fireplace.

PRELIMINARY PREPARATION

1. Contents of kit:
 - 16" Snap Lock Starter pipe - cut to desired length (See Figure 2 on page 2).
 - Mounting Plate
 - Adapter
 - Fan Housing Assembly
 - Return Air Grille
 - Variable Speed Wall Rheostat
 - Fastener Package (Part number 13580)

If any parts are missing or damaged, contract your dealer before starting installation. DO NOT install a damaged kit.

Possible Air Duct Runs / Locations

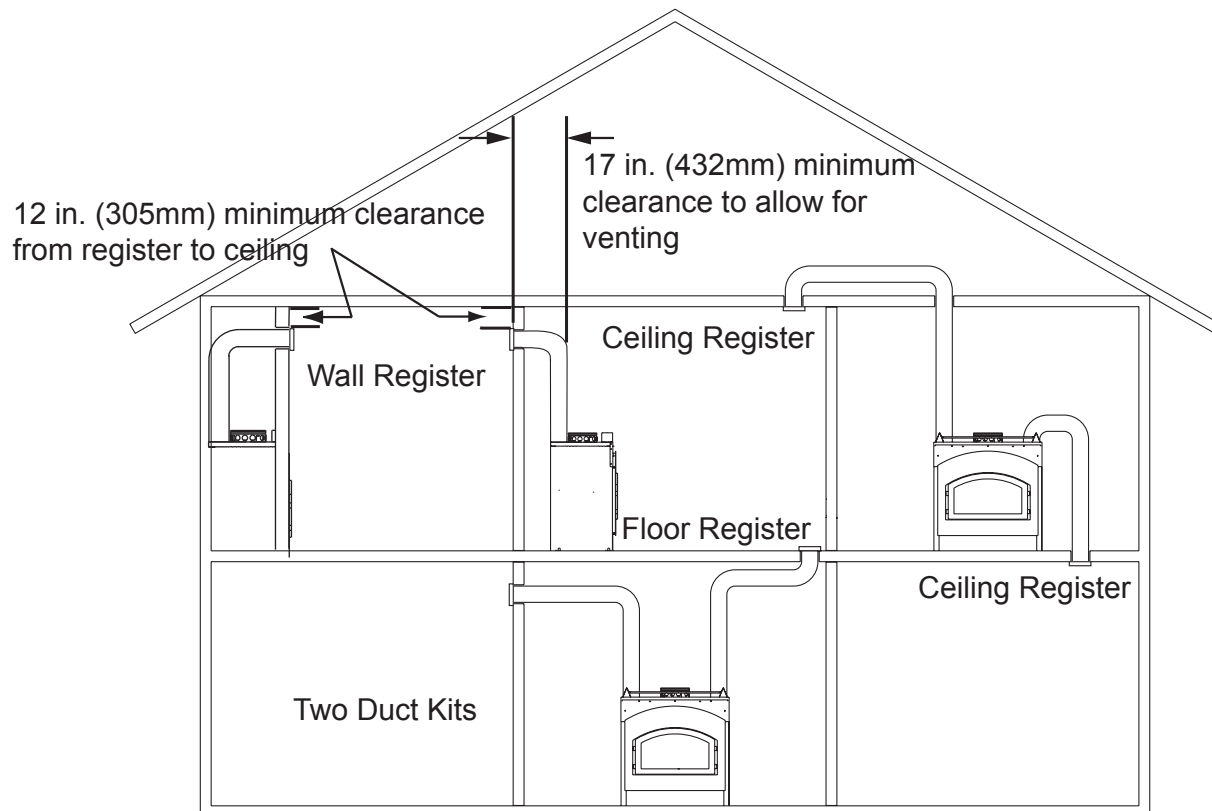

Figure 1

2. REQUIREMENTS AND INSTALLATION

The Heat-Zone accessory kit conveys warm air from the fireplace through air duct(s) to remote locations in the same room or other rooms of the building. You may install 1 or 2 Heat-Zone kits on the fireplace. Installation of this kit **MUST** be performed by a qualified service technician. If any parts are missing or damaged, contact your local dealer before starting installation. **DO NOT** install a damaged kit.

This kit is tested and safe when installed in accordance with this installation manual. It is your responsibility to read all instructions before starting installation and to follow these instructions carefully during installations.

The Heat-Zone-WD kit is carefully engineered and must be installed only as specified. If you modify it or any of its components you will void the warranty and you may possibly cause a fire hazard. Installation must be done according to applicable local, state, provincial and/or national codes.

Plan the location of the fireplace and warm air duct run(s).

DUCT RUN REQUIREMENTS

MAXIMUM Duct Run = 40-ft. (12 m)

MINIMUM Duct Run = 36 in. (914 mm)

DUCTING MATERIAL

6 in. (152 mm) B-vent Only

DO NOT duct into existing furnace plenum

MINIMUM CLEARANCE TO COMBUSTIBLES

1 in. (25 mm) from the B-vent

0 in. (0 mm) from top & bottom of outlet box

0 in. (0 mm) from the sides of outlet box

12 in. (305 mm) from wall register to ceiling

Refer to Figure 1

CAUTION! ALL wiring should be done by a qualified electrician and shall be in compliance with local codes and with the National Electric Code NFPA/NEC No. 70-current. CSC22.1 Canadian Electric Code.

Installation

- Remove the knockout or cover plate from the top of the fireplace and discard it. See Figure 2.
- Cut a 3 in. (76 mm) hole in the insulation board and remove it as per the dimensions shown in Figure 2.

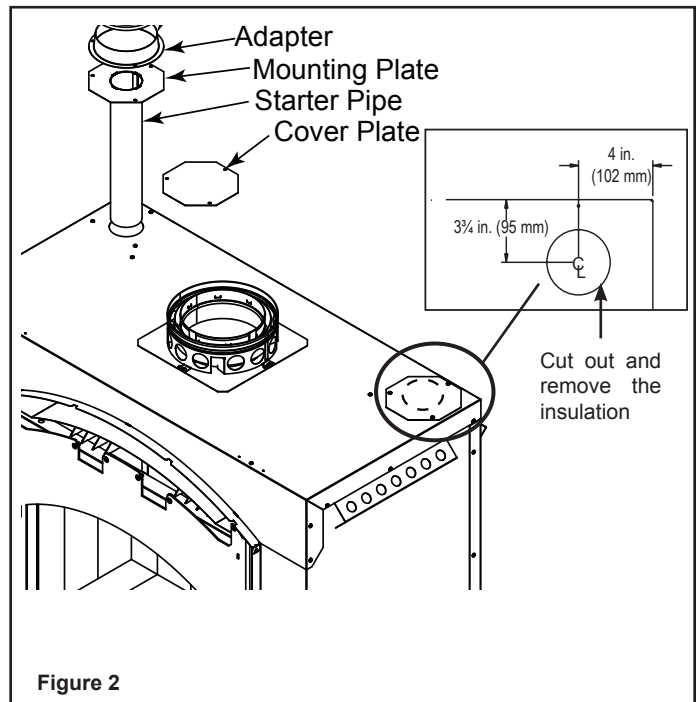

Figure 2

- Determine the necessary length of starter pipe from Table 1 and cut as required.

Table 1

Run Length	Cut Pipe
20 - 40 ft (6-12 m)	2 in. (51 mm)*
*A minimum of 2 in. (51 mm) pipe must be used to cover the raw insulation to prevent it from blowing out through the return air grille.	
10 - 20 ft (3 - 6 m)	8 in. (203 mm)
3 - 10 ft (1 - 3 m)	12 in. (305 mm)
**Do not use full 16 in. (406 mm) as supplied, it must be cut down.	

NOTE: It is important the pipe length be adhered to or it will affect the performance of your fireplace.

- On the mounting plate, hand bend the tabs downward. Slide the tabs over the outside of the starter pipe. Secure with four sheet metal screws included in fasteners package. Figure 3.

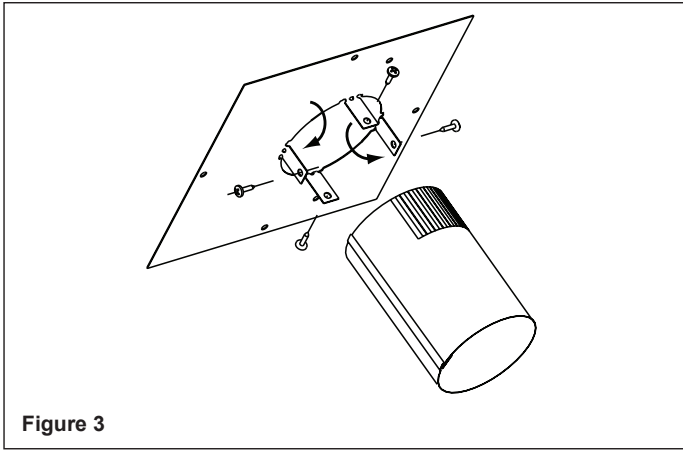

Figure 3

- Slide the starter pipe into the fireplace, matching the holes in the plate to the holes in the fireplace.
- Place the adapter on the mounting plate lining up holes. Using four sheet metal screws included in the kit, secure the adapter and mounting plate into fireplace. After securing to the fireplace, tape down the adapter edges to the top of the fireplace with aluminum tape to prevent leakage.

- Determine the location for the air register and fan housing assembly. Cut a 6-3/4 in. x 13-1/8 in. (213 mm x 333 mm) hole between framing members (wall studs or floor joists). Attach the brackets to the fan housing with the screws provided. The brackets can be rotated 180° and mounted to the back side of the 2 x 4 if necessary. See Figure 4.

NOTICE: The fan and electrical connections must be accessible for servicing per local code requirements.

- Attach enough 6 in. (152 mm) B-Vent as required for your installation to the fan housing. **A maximum of (4) 90° elbows is recommended.** Screw the B-vent to the adapter.

Also screw the B-vent to the outlet box on the fan housing. See Figure 5. Support duct at intervals of no greater than 4 ft (1 m) as required by local code.

WARNING! Risk of Fire! Comply with all minimum clearances specified.

- A minimum 1 in. (25 mm) air clearance must be maintained at the back and 1½ in. (38 mm) to the sides of the fireplace assembly.

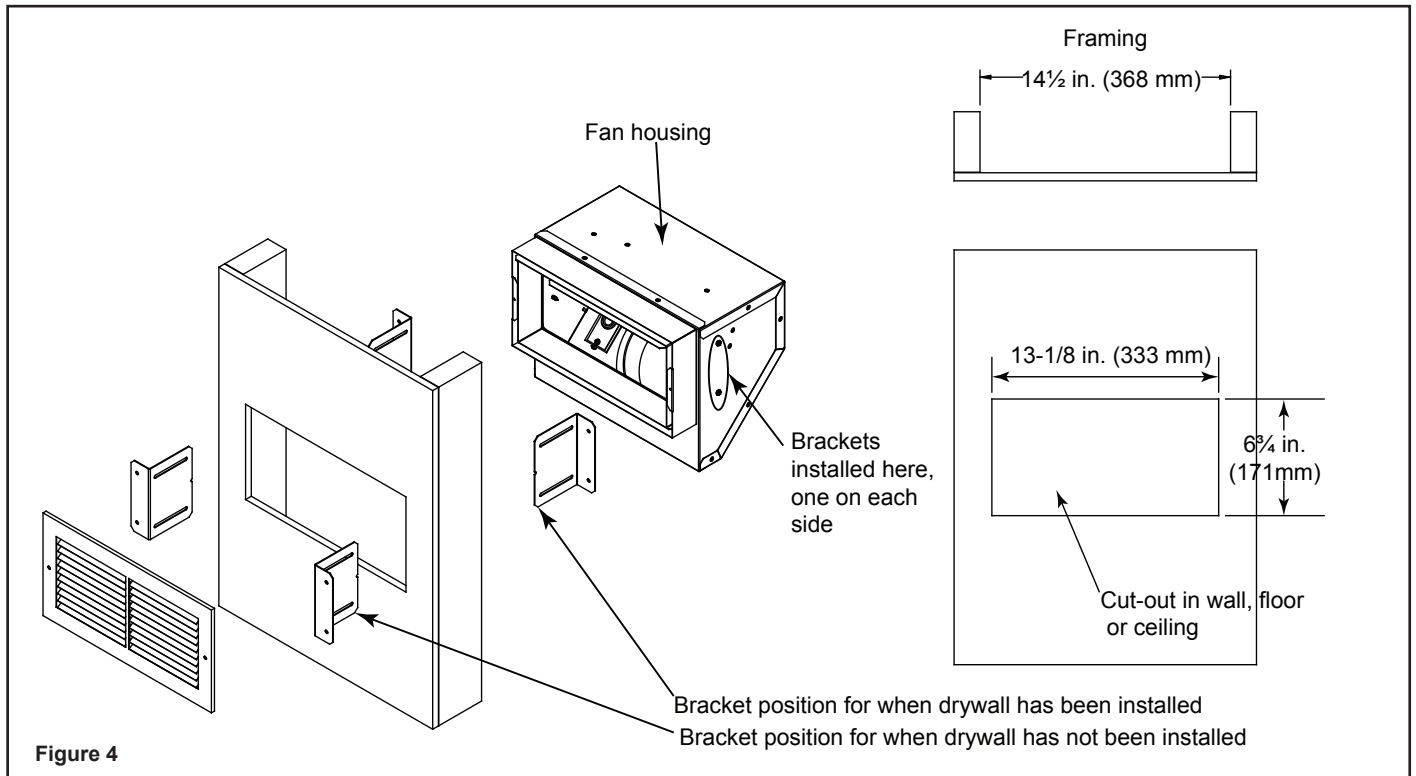

Figure 4

NOTICE: Secure the duct so that clearance to the fireplace outer wrap is maintained. Tape all seams with aluminum tape 1-1/4 in. (32 mm) minimum width or as specified by local codes.

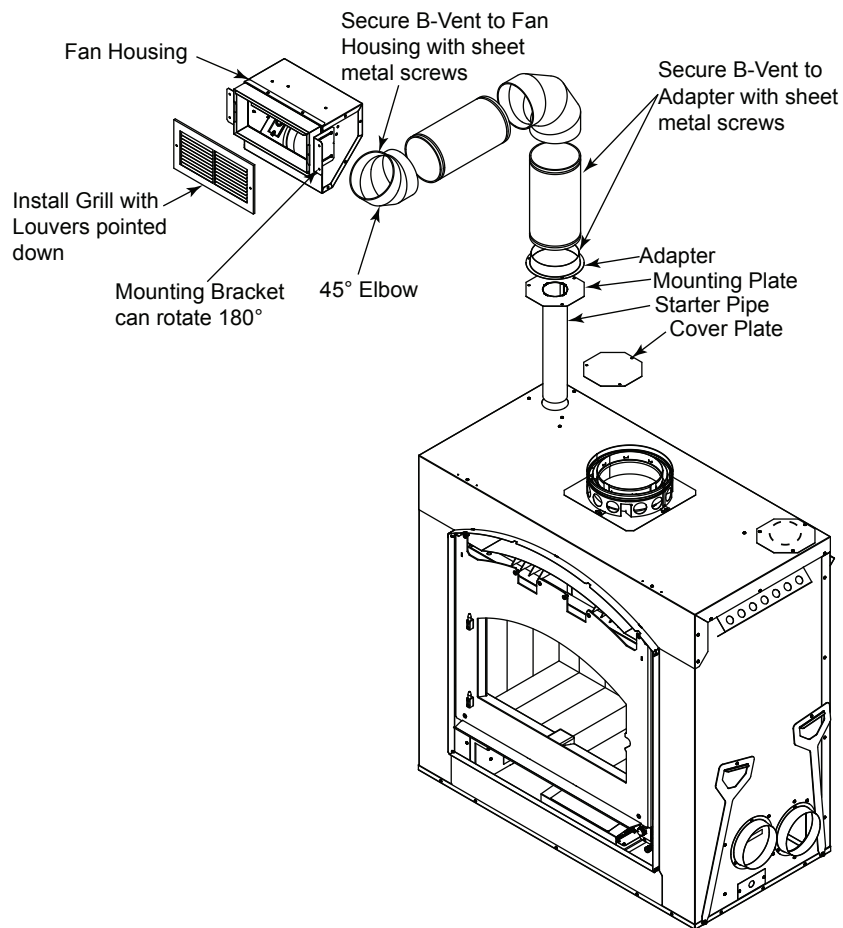

Figure 5

Installing Fan In Housing

- Attach the (2) wires to the spade terminals on the fan motor.
- Tilt the fan forward to clear the mounting brackets then lift the fan onto the brackets. See Figure 7.
- Insert fan into the fan housing starting with motor end first. Slip it below the "L" bracket on the left side allowing the right side to drop in. See Figure 6.

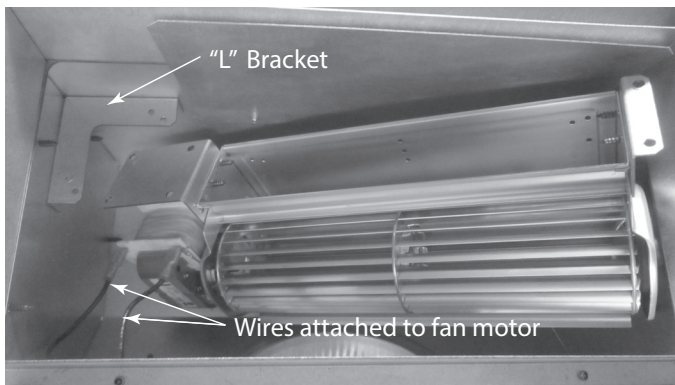

Figure 6

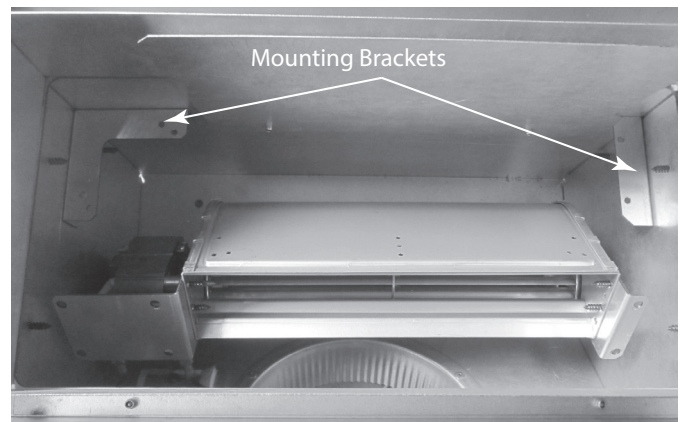

Figure 7

- Secure the fan to the mounting brackets with (4) screws provided. See Figure 8.

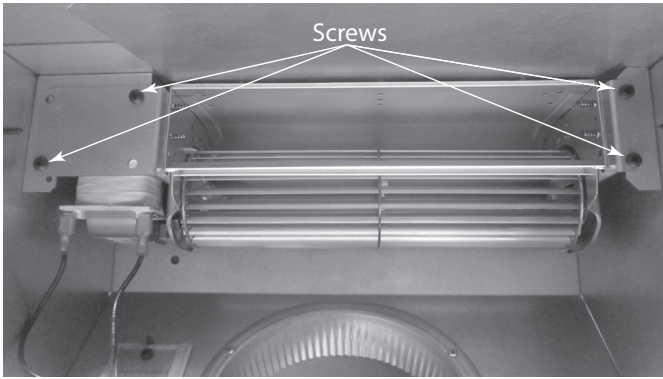

Figure 8

- Insert the fan wires through the grommet and into the junction box. See Figure 9.

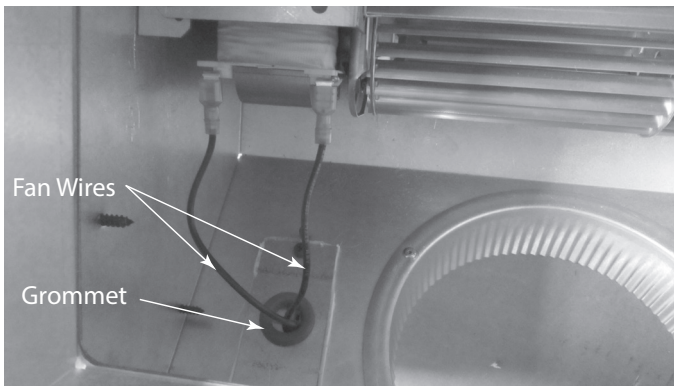

Figure 9

- Install the variable speed wall rheostat (with setting on "OFF") in a convenient location. This switch will control the Heat-Zone fan operation.
- Remove the junction box. Wire 110 VAC service TO the wall rheostat and FROM the wall rheostat to the fan junction box. Use wire nuts to secure the 110 VAC service wires to the hot (black) and neutral (white) fan wires and screw the 110 VAC ground wire to the junction box. See Figure 10.
- Secure the return air grille to the fan housing making sure it is flush. The grille must be installed with the louvers pointing down.

NOTICE: DO NOT USE ADJUSTABLE REGISTERS.

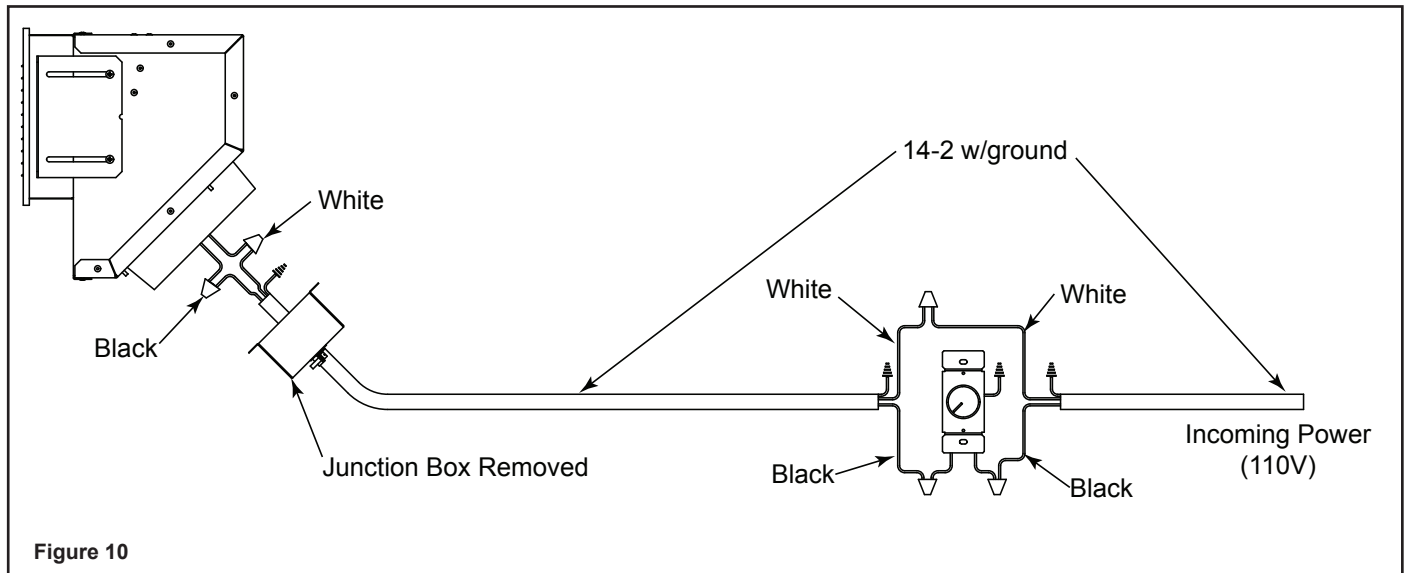

Figure 10