

## AC POWERED ELECTRONIC PILOT KIT



(Suitable for G4 and G45 series burners)

- HOT SURFACE IGNITION PILOT
- REMOTE OR MANUAL OPERATION
- AC POWER OPERATION

### EPK-05 PILOT KITS

#### **WARNING**

If the information in this manual is not followed exactly, a fire or explosion may result, causing property damage, personal injury, or loss of life.

Do not store or use gasoline or other flammable vapors and liquids in the vicinity of this or any other appliance.

#### **WHAT TO DO IF YOU SMELL GAS:**

- Open a window.
- Do not try to light any appliance.
- Do not touch any electrical switch; do not use any phone in the building.
- Immediately call the gas supplier from a neighbor's phone and follow the gas supplier's instructions.
- If you cannot reach the gas supplier, call the fire department.

**Installation and service must be performed by an NFI Certified or other qualified professional installer, service agency, or the gas supplier.**

#### **INSTALLER & CONSUMER**

These instructions **MUST** be retained with this appliance

**Important:** Read these instructions carefully before starting installation of the burner control system.

The Peterson Real Fyre burner system is to be installed only in a solid-fuel-burning fireplace with a working flue constructed of noncombustible material. Solid fuels shall not be burned in a fireplace where the unit is installed. The installation, including provisions for combustion, ventilation air, and required minimum permanent vent opening, must conform with the *National Fuel Gas Code (ANSI Z223.1/NFPA 54)* and applicable local building codes. In Canada, the installation must conform with the *Natural Gas and Propane Storage and Handling Installation Code (CSA-B-149.1)*. A damper stop clamp is included to maintain the minimum permanent vent opening and to prevent full closure of the damper blade. **The chimney damper must be fixed fully opened when burning the unit. The burner system is designed to burn with yellow flames; thus, adequate ventilation is absolutely necessary.**



We recommend that our gas hearth products be installed and serviced by professionals who are certified in the U.S. by the National Fireplace Institute® (NFI) as NFI Gas Specialists.

# TABLE OF CONTENTS

TABLE OF CONTENTS .....	2
IMPORTANT INFORMATION .....	3
WIRING DIAGRAM.....	3
ELECTRICAL SAFETY INFORMATION .....	4
SPECIFICATIONS.....	4
PARTS LIST .....	5
INSTALLATION.....	6
<i>PREPARATION</i> .....	6
<i>ORIENTATION</i> .....	6
<i>CREATE VALVE HOUSING OPENING/FRAME</i> .....	6
<i>INSTALL THE FLAME DIVERTER BRACKET</i> .....	6
<i>INSTALL THE PILOT/IGNITER ASSEMBLY TO THE BURNER</i> .....	7
<i>CONNECT THE VALVE TO THE GAS SUPPLY</i> .....	7
<i>CONNECT THE VALVE TO BURNER</i> .....	7
<i>LEAK TEST</i> .....	7
<i>CONNECT THE IGNITOR PACK TO A POWER SUPPLY</i> .....	8
<i>SECURE THE VALVE HOUSING</i> .....	8
05 VALVE SERIES LIGHTING INSTRUCTIONS.....	9
TROUBLESHOOTING.....	10
FUSE REPLACEMENT .....	10
NOTES PAGE .....	11
WARRANTY .....	12

## IMPORTANT INFORMATION

### CHECK TO BE SURE THAT THE PROPER FUEL GAS IS BEING USED WITH THIS PILOT KIT.

The installation, including provisions for combustion and ventilation air, must conform with local codes, or in the absence of local codes, with the National Fuel Gas Code (ANSI Z223.1/NFPA 54).

This component and its individual shutoff valve must be disconnected from the gas-supply piping system when testing at pressures that exceed  $1/2$  psig. This is accomplished by closing the gas-supply line valve.

This component must be isolated from the gas-supply piping system by closing its individual manual shutoff valve during any testing of the gas-supply system at test pressures up to and including  $1/2$  psig.

A fireplace screen must be in place when the gas burner system is in operation. Unless other provisions for combustion air are provided, the screen shall have an opening(s) for introduction of combustion air.

### WHEN GLASS FIREPLACE ENCLOSURES (DOORS) ARE USED, OPERATE THE BURNER SYSTEM WITH THE GLASS DOORS FULLY OPEN; BOTH SIDES IF THE FIREPLACE IS A SEE-THROUGH TYPE.

This appliance may be installed in an aftermarket, permanently located, manufactured (mobile) home where not prohibited by local codes. Installation of appliances designed for manufactured homes or mobile homes must conform with *Manufactured Home Construction and Safety Standard, Title 24 CFR, Part 3280* in the U.S.; or with *CAN/CSA Z240 MH* in Canada; or with *ANSI/NCSCS A225.1/NFPA 501A, Manufactured Home Installations Standard* when such as standard is not applicable.

Do not use this appliance if any part has been underwater. Immediately call a qualified service technician to inspect the appliance and to replace any part of the control system and any gas control that has been underwater.

## WIRING DIAGRAM

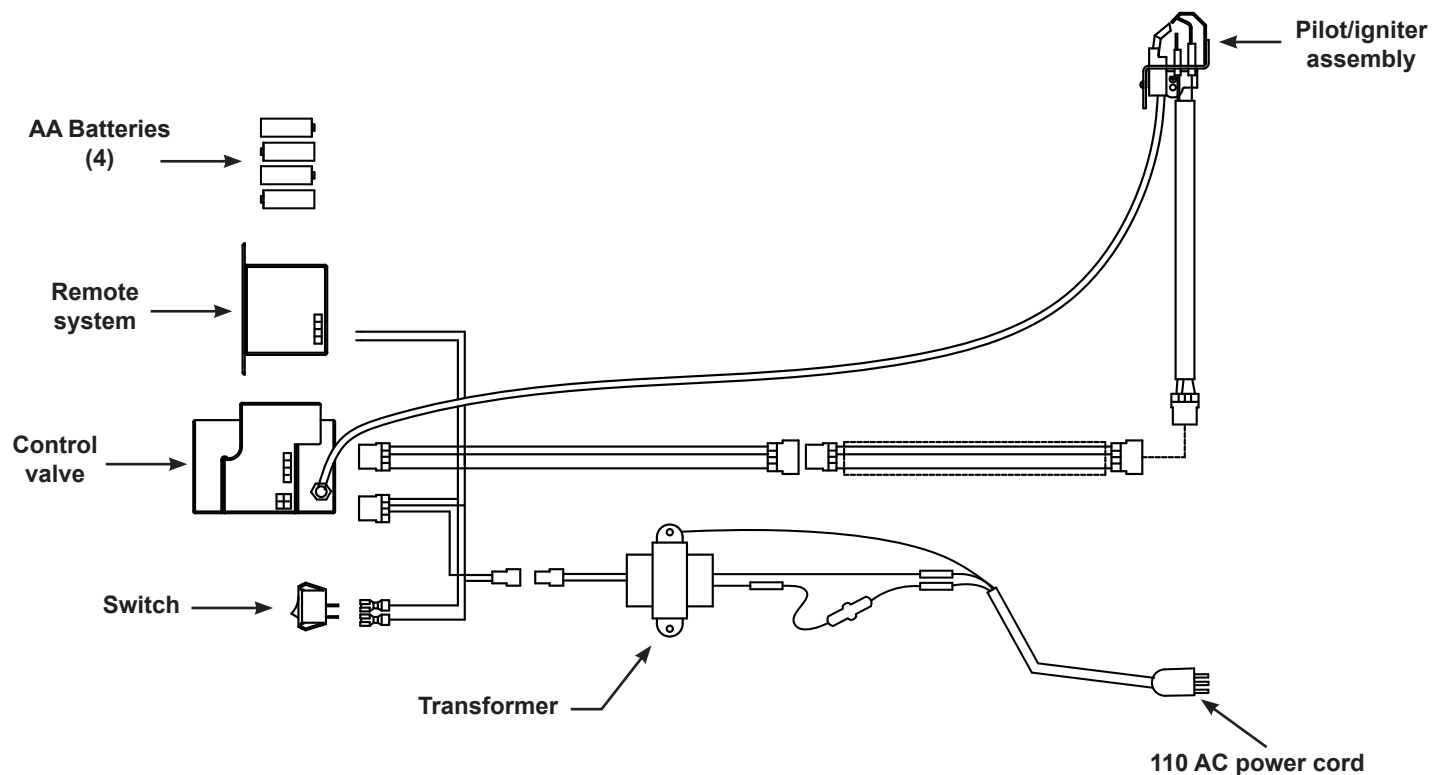

Fig. 3-1

## ELECTRICAL SAFETY INFORMATION

- To protect against electric shock, do not immerse cord or plugs in water or other liquid.
- Unplug from the outlet before servicing. Allow to cool before putting on or taking off parts.
- Do not operate with a damaged cord, plug, or after the appliance malfunctions or has been damaged in any manner. Contact the manufacturer for repair.
- Do not let the cord touch hot surfaces.
- When connecting, first make wire connections then plug appliance into the outlet.
- Do not use for purposes other than intended.
- **Use only a properly wired and inspected 120VAC (15 AMP minimum) Ground Fault Circuit Interrupter (GFCI) GROUNDED 3-wire receptacle with this unit.**
- Use only extension cords with a 3 prong grounding plug and rated for the power of the equipment.
- **The provisions of the National Electric Code as well as any local codes must be observed when installing the product.**

## SPECIFICATIONS

The **EPK-05** accommodates burners up to 60" (nat. gas only).  
 The **EPK-05P** accommodates burners up to 60" (L.P. gas only).

Refer to the burner owner's manual for minimum firebox dimensions.

Model	BTUs	
	Nat.	L.P.
EPK-05(P)	200k	200k

**Table 1** - Maximum BTUs

Specification	Value	Qty.
Input electrical requirements	120VAC / 15 AMP minimum / 60 Hz / GFCI outlet	N/A

**Table 2** - Technical Data

# EPK-05 REPLACEMENT PARTS LIST

Note: Photos not to scale

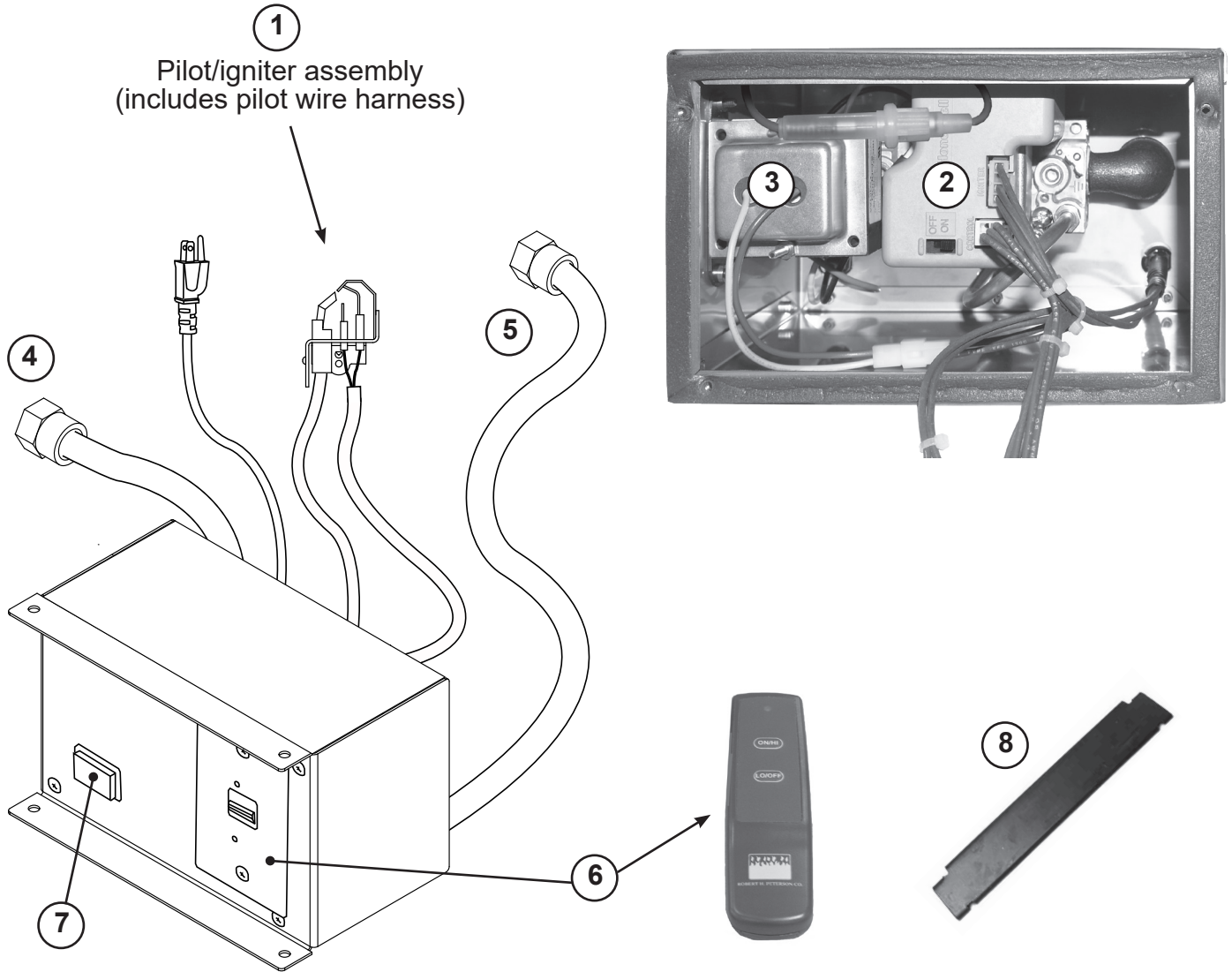

## Replacement parts list

Item	Description	Part No.	Qty.
1.	Pilot assembly (natural/propane)	PAC-8	1
2.	Control valve	SV-44	1
3.	Transformer	TRN-01	1
4.	Flex connector 24"	CK-5-24SP	1
5.	Flex connector 36"	CK-5-36	1
6.	Remote kit	RR-1A	1
7.	Switch	SW-11	1
8.	Flame diverter bracket	SH-1	1

# INSTALLATION

This safety pilot system must be installed by a qualified professional service technician. Instructions must be followed carefully when installing to ensure proper performance and full benefit from the burner system and safety pilot system.

These instructions must be used as a supplement to the instructions supplied with the Peterson burner system. Follow the burner system instructions and make adjustments as appropriate for the addition of a safety pilot system. Use gas pipe sealing compound that is resistant to all gasses (or Teflon tape) and apply to all male pipe connections. Make sure that all connections are tight.

The valve system is shipped pre-assembled for easy installation onto the burner pan. **Perform installation with care ensuring not to damage the pilot assembly.**

## PREPARATION

If the burner that the valve system is to be added to is already installed, remove all decorative media, set aside to be reinstalled later, and disconnect the flex connector and adapter from the burner pan (using the instructions that came with the original burner).

## ORIENTATION

Prior to installation, please review and determine the orientation of this unit by referencing Fig. 6-1. **Be sure the location of the valve housing is within reach of the burner (for flex connector and pilot/igniter assembly), the gas supply (for flex connector), and the 110V receptacle (for transformer adaptor).**

## CREATE VALVE HOUSING OPENING/FRAME

The valve housing must be secured in an opening/frame within the allowed range of the burner as mentioned in Fig. 6-1. The cutout for the valve housing is  $8\frac{5}{8}$ " wide by  $5\frac{1}{2}$ " high, with a depth of  $7\frac{7}{8}$ " (see Fig. 6-2). Be sure to allow for wires/tubing clearance behind the housing. The valve housing will be secured upon completion of installation. (See SECURE VALVE HOUSING section.)

## INSTALL THE FLAME DIVERTER BRACKET

For installation on G4/G45 burners only. When properly installed onto the burner pan, the flame diverter bracket will promote quicker ignition and protect the safety control system from overheating.

**Note:** You must first install the flame diverter bracket before installing the pilot/igniter assembly. Use only the pilot/igniter assembly pre-assembled with this kit. Never substitute with an existing pilot.

1. Place the flame diverter bracket over the side edge of the burner pan, near the location the safety control system pilot bracket will be attached. It should be placed **approximately  $2\frac{1}{2}$ "** from the rear wall of the burner pan (see Fig. 6-3).
2. Tap the bracket lightly with a hammer to secure it in place.

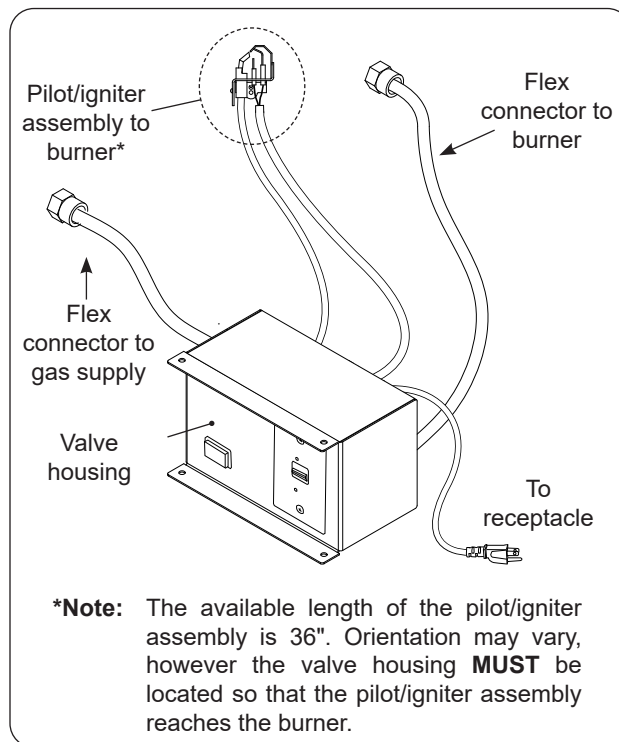

Fig. 6-1

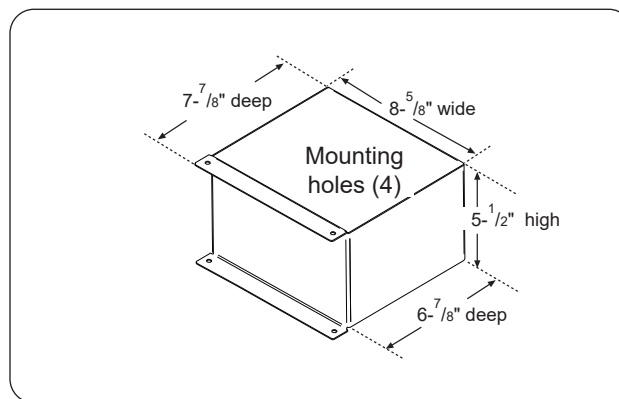

Fig. 6-2

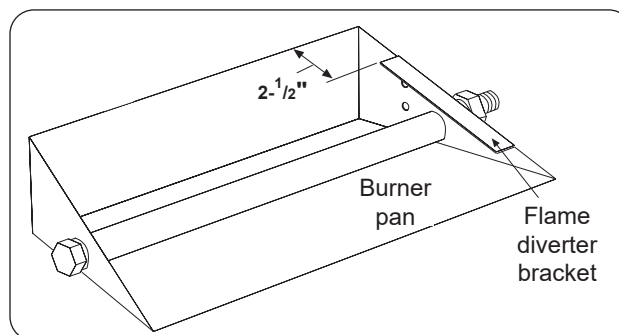

Fig. 6-3

## INSTALL THE PILOT/IGNITER ASSEMBLY TO THE BURNER

**CAUTION:** Do not kink or damage the pilot supply tube, sparking, and sensor probes. Do not unscrew the gas line from the valve.

1. Route the pilot/igniter assembly coming from the valve system to the burner.
2. Remove the two existing screws on the right side of the burner, align the pilot in place, and fasten using the provided screws. See Fig. 7-1. **Check to be certain the pilot hood and probes are situated above the edge of the pan. Adjust if necessary.**

**WARNING:** Keep the pilot/igniter assembly clear at all times. Never cover any part of the pilot/igniter assembly.

## CONNECT THE VALVE TO THE GAS SUPPLY

1. **Be sure gas to the fireplace is off.** Locate the 1/2" flex connector coming from the rear of the valve system that is attached to the **IN** adapter. Route the connector to the gas supply stub.
2. Remove the adapter that is loosely connected to the flex connector. Attach the adapter to the gas-supply stub using a pipe compound resistant to all gasses. Tighten securely. Then attach the open end of the flex connector to the adapter. Tighten securely (See Fig. 7-2).

## CONNECT THE VALVE TO BURNER

1. Locate the 1/2" flex connector coming from the rear of the valve system that is attached to the **OUT** adapter. Route the connector to the burner.
2. Remove the adapter that is loosely connected to the flex connector. Attach the adapter to the fuel injector or air mixer on the burner using a pipe compound resistant to all gasses. Tighten securely. Then attach the open end of the flex connector to the adapter. Tighten securely (See Fig. 7-3).

## LEAK TEST

Turn on the fireplace gas supply, and test at all connections for leaks using the appropriate soapy water solution. If bubbles appear, a leak is present. Turn off the gas and tighten at all connections. Repeat until no leaks are present. If a leak persists, turn off the gas supply and contact the local gas company or dealer.

**NEVER USE A FLAME TO CHECK FOR LEAKS.**

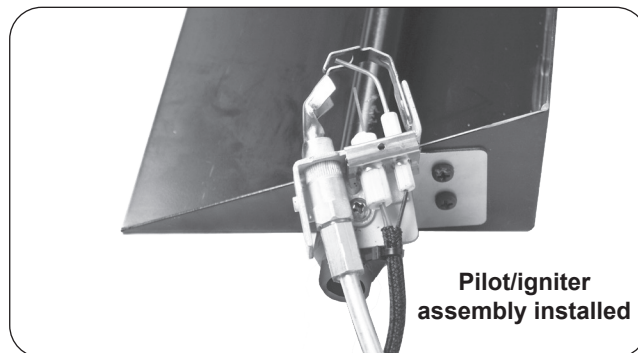

Fig. 7-1

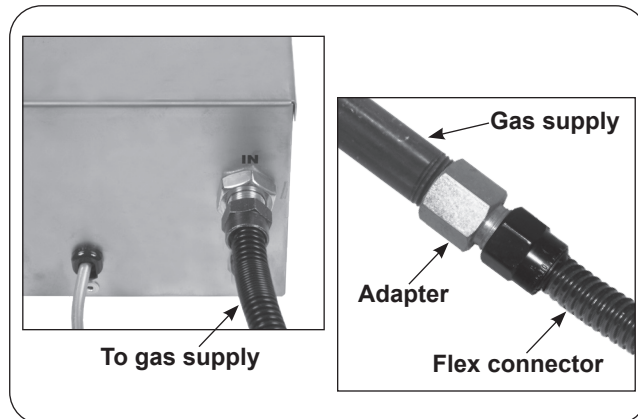

Fig. 7-2

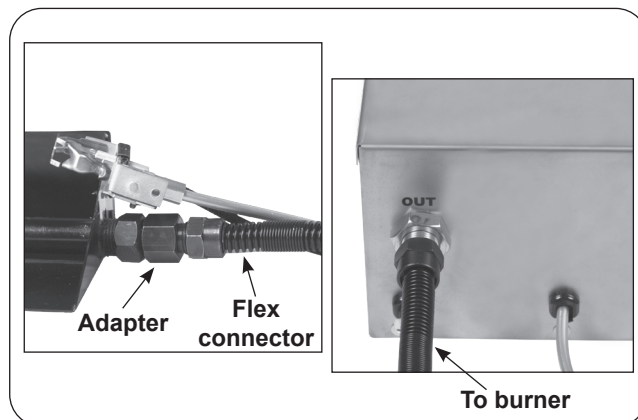

Fig. 7-3

## INSTALLATION (Cont.)

### CONNECT THE IGNITOR PACK TO A POWER SUPPLY

Route the cord(s) (coming from valve box and/or power supply) to the previously wired **120VAC (15AMP minimum) GFCI GROUNDED 3-wire receptacle** and connect (see Fig. 8-1).

### SECURE THE VALVE HOUSING

Align the housing into the opening/frame (previously made) and fasten the housing in using four screws (not provided).

**Important:** Be sure all wires/tubing are completely inside the opening and are not pinched or kinked when fastening the housing. See Fig. 8-2 & Fig. 8-3.

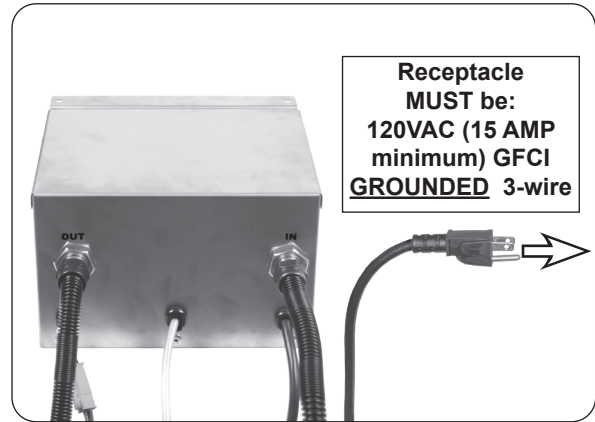

Fig. 8-1

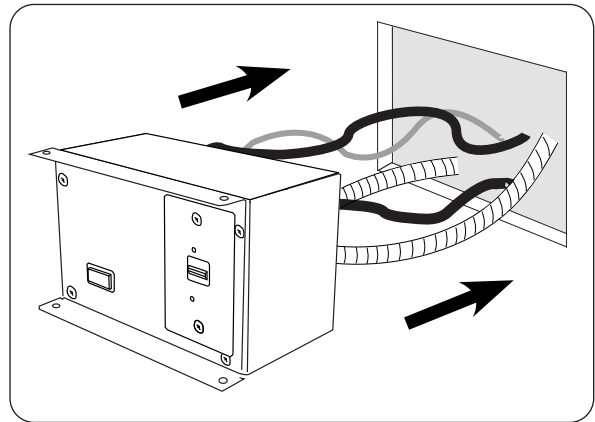

Fig. 8-2



Fig. 8-3



# OPERATING THE UNIT - LIGHTING AND EXTINGUISHING

## FOR YOUR SAFETY, READ BEFORE LIGHTING

**WARNING: IF YOU DO NOT FOLLOW THESE INSTRUCTIONS EXACTLY, A FIRE OR EXPLOSION MAY RESULT, CAUSING PROPERTY DAMAGE, PERSONAL INJURY, OR LOSS OF LIFE.**

- A. BEFORE LIGHTING**, smell all around the unit area for gas. Be sure to smell next to the floor, because some gas is heavier than air and will settle on the floor.
- B. WHAT TO DO IF YOU SMELL GAS**
1. **Shut off the gas to the appliance.**
  2. **Extinguish any open flame.**
  3. **If odor continues, immediately call your gas supplier or the fire department.**
- C.** Use only your hand to push in or move the controls. Never use tools. If the control will not push in or move by hand, **DO NOT** try to repair it. Call a qualified professional service technician. Force or attempted repair may result in fire or explosion.
- D. DO NOT** use the unit if any part has been underwater. Immediately call a qualified service technician to inspect the unit and to replace any part of the control system and any gas control that has been underwater.

## 05 VALVE SERIES LIGHTING INSTRUCTIONS

**Note:** For any lighting method, no gas will flow to the main burner unless the pilot is lit and stable.

1. **STOP!** Read the safety information above.
2. Turn the gas valve to the **ON** position.
3. **Lighting the unit using remote handset**
  - a. Ensure the main switch is in the **OFF/REMOTE** position.
  - b. Slide the ON/REMOTE/OFF switch (O/R/O) to **REMOTE** setting (see Fig. 9-1).
  - c. Point the top of the remote handset toward the control panel and press the **ON** button on the handset. The valve will begin its lighting sequence and the pilot will light. When the pilot flame becomes stable (about 10 seconds), gas will flow to the main burner, and it will ignite.
4. **Lighting the unit without using the remote**
  - a. Slide the ON/REMOTE/OFF switch to the **ON** setting, **OR**, press the main switch to the **ON** position. The valve will begin its lighting sequence and the pilot will light. When the pilot flame becomes stable (about 10 seconds), gas will flow to the main burner, and it will ignite.

### SHUTTING OFF THE UNIT

5. **Shutting off the unit using remote handset**
  - a. Slide the ON/REMOTE/OFF switch (O/R/O) to **REMOTE** position (center).
  - b. Point the top of the remote handset toward the control panel and press the **OFF** button (handset). Main burner and pilot will extinguish.
6. **Shutting off the unit without using remote**
  - a. With the main switch in the **OFF/REMOTE** position; slide the ON/REMOTE/OFF switch to the **OFF** setting. Main burner and pilot will extinguish.

**Fig. 9-1 control panel**



**Fig. 9-1 Control panel**

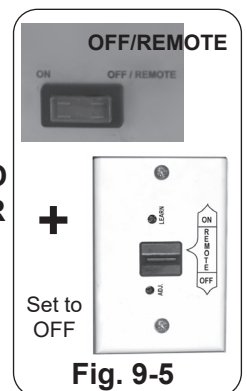
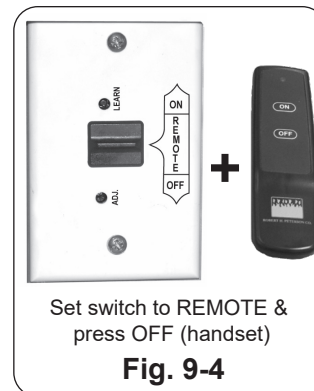
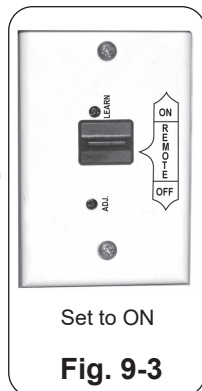

# TROUBLESHOOTING

PROBLEM	CAUSE	SOLUTION
1. Pilot will not light	<ul style="list-style-type: none"> <li>a. Obstruction in pilot gas supply or pilot gas-supply line is kinked</li> <li>b. Inadequate gas supply</li> <li>c. Air in line</li> </ul>	<ul style="list-style-type: none"> <li>a. Clear out obstruction. Replace pilot gas-supply line if kinked</li> <li>b. Have gas pressure checked by installer or gas supplier</li> <li>c. Air should clear; attempt to relight</li> </ul>
2. Hot surface igniter not operating	<ul style="list-style-type: none"> <li>a. Loose wires</li> <li>b. Bad igniter</li> <li>c. Valve not operating properly</li> </ul>	<ul style="list-style-type: none"> <li>a. Check all wires are securely in place</li> <li>b. Replace igniter</li> <li>c. Replace valve</li> </ul>
3. Pilot lights, but main burner will not	<ul style="list-style-type: none"> <li>a. Wire leads are not connected to proper valve terminals</li> <li>b. Improper pilot flame sensor adjustment</li> <li>c. Defective valve</li> </ul>	<ul style="list-style-type: none"> <li>a. Make sure all wire leads are tight and attached to proper terminals (see wiring diagram on p. 3, Fig. 3-1)</li> <li>b. Adjust pilot flame sensor</li> <li>c. Replace valve</li> </ul>
4. Burner system not burning properly	<ul style="list-style-type: none"> <li>a. Low flame/uneven flame</li> </ul>	<ul style="list-style-type: none"> <li>a. Check for low gas pressure; should have operating pressures of 7" w.c. for natural gas, 11" w.c. for propane at manifold</li> <li>b. Burner should be filled completely with sand or vermiculite</li> </ul>
5. Burner system shuts down during operation	<ul style="list-style-type: none"> <li>a. Glass doors closed, causing excessive heat buildup</li> <li>b. Pilot flame sensor not properly set to pilot location</li> <li>c. Heat shield not in place</li> </ul>	<ul style="list-style-type: none"> <li>a. Open glass doors</li> <li>b. See p. 6 (INSTALL THE PILOT ASSEMBLY TO THE BURNER)</li> <li>c. Place heat shield over valve. Be sure the solid black face of the shield is between the valve and the burner</li> </ul>

Periodically inspect the pilot assembly and valve controls and maintain them free of obstruction or debris. If the pilot flame is not blue with possibly yellow tips and does not impinge on the electrodes or if the pilot does not stay lit, contact a qualified professional service technician to service the pilot system.

## FUSE REPLACEMENT

1. Using a Phillips screwdriver, remove the 4 screws found on the front of the valve housing (see Fig. 10-1).
2. Carefully open the box by pulling its cover away.
3. "Push in and twist" the fuse holder (red wire), exposing the fuse. See Fig. 10-2.
4. Replace the fuse accordingly (3AG 2 AMP).

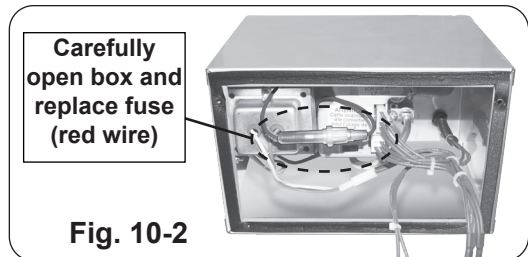
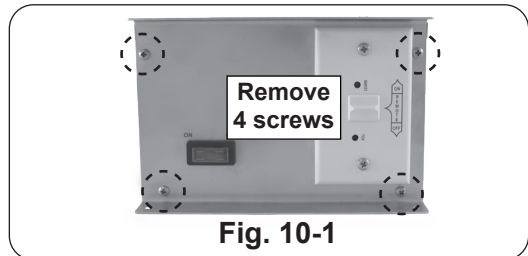

Please use this page to record any information that you may want to have at hand.

# WARRANTY

## PETERSON VENTED DECORATIVE GAS APPLIANCE LIMITED WARRANTY

Robert H. Peterson Co. ("RHP") warrants your Real Fyre vented decorative gas appliance to be free from defects in material and workmanship. Peterson vented refractory gas logs are warranted for **as long as the original purchaser owns them (lifetime) when used indoors and for THREE (3) YEARS when used outdoors.**

Peterson vented fiber-ceramic blended gas logs are warranted for **FIVE (5) YEARS when used indoors and for THREE (3) YEARS when used outdoors.**

Peterson **indoor** vented gas log burners and stainless steel burners (excluding controls) are warranted for **TEN (10) YEARS.**

Peterson **outdoor** vented stainless steel burners (excluding controls) are warranted for **FIVE (5) YEARS.**

The **SPK-26** is warranted for **THREE (3) YEARS** and **APK-17** (including -17 valve) is warranted for **TWO (2) YEARS.**

All other valves, pilots, and controls are warranted for **ONE (1) YEAR** (excluding batteries).

Peterson glass, gems, and nuggets are warranted for **TEN (10) YEARS.**

### A COPY OF YOUR SALES SLIP FOR PROOF OF PURCHASE IS REQUIRED

This warranty applies to the original purchaser for products which are installed in the United States or Canada and which are operated and maintained as intended for single family residential usage. This warranty is valid only with proof of purchase, commences on the date of purchase, and terminates (both as to original and any replacement products) on the anniversary date of the original purchase of the product per the above schedules.

This warranty covers defects in material and workmanship. This warranty **does not** cover parts which become defective as a result of negligence, misuse, use not in compliance with the Installation and Owner's Manual, accidental damage, improper handling, improper storage, improper installation, **lack of required routine maintenance** (as specified in the Installation and Owner's Manual), electrical damage, local gas impurities or failure to protect against combustible materials. Product must be installed (and gas must be connected) as specified in the Installation and Owner's Manual by a **qualified professional installer**. This warranty **does not** apply to rust, corrosion, oxidation, or discoloration unless the affected part becomes inoperable. Peterson products including valves, pilots and controls, are designed and certified to be used as a system. Modifications to products which are not specifically authorized will void this warranty and could render the product to be unsafe. Burners, valves, parts, accessories, remotes, etc. used with this product must be Peterson products or this warranty is void.

Warranted items will be repaired or replaced at Peterson's sole discretion. This warranty **does not** cover labor or labor related charges, except as provided by separate specific written programs from the Peterson Co. All repair work must be performed by a qualified professional service person and requires prior approval of Peterson.

Peterson may require the defective product or part to be returned to the factory to determine the cause of failure. Peterson will pay freight charges if the product or part is determined to be defective. This warranty does not cover breakage in shipment from our independent distributor to its customer if the damage is determined to have occurred during that shipment.

This warranty specifically excludes liability for **indirect, incidental, or consequential** damages. Some states and provinces do not allow the exclusion or limitation of incidental or consequential damages, so the above exclusion may not apply to you. This warranty gives you specified legal rights, and you may have other rights that vary from state to state or province.

For additional information regarding this warranty, or to place a warranty claim, contact the R.H. Peterson dealer where the product was purchased.

When contacting your Peterson dealer or the R.H. Peterson Co., please provide the following information:

- Your name, address, telephone number, e-mail
- Sales receipt showing where purchased and date purchased
- Model number, serial number of product, date code
- Relevant information: installer, additions, repairs, when defect was first noted

**TO REGISTER YOUR PRODUCT ONLINE GO TO: [WWW.RHPETERSON.COM](http://WWW.RHPETERSON.COM),  
AND CLICK ON PRODUCT REGISTRATION. THANK YOU FOR YOUR PURCHASE.**

<b>Quality Check</b>		<b>Date:</b> _____	
<b>Leak Test:</b> _____	<b>Burn Test:</b> _____	<b>Gas Type:</b> <u>Nat.</u> / <u>L.P.</u>	
<b>Inspector:</b> _____			