



Installation and Operation Instructions

Unvented (Vent-Free) Gas Log Heater

P/N 900743-00 Rev. E 09/2020



Models

MNF24INE MNF24IPE MNF30INE MNF30IPE

For use with log sets

LMF24GTA/B	LMF24MOA/B
LMF30GTA/B	LMF30MOA/B
LMF36GTA/B	LMF36MOA/B

INSTALLER: Leave this manual with the appliance.

CONSUMER: Retain this manual for future reference.

This appliance may be installed in an aftermarket permanently located, manufactured (mobile) home, where not prohibited by local codes. This appliance is only for use with the type of gas indicated on the rating plate. This appliance is not convertible for use with other gases.

WARNING: This appliance is for installation only in a solid-fuel burning masonry or UL127 factory-built fireplace or in a listed ventless firebox enclosure. It is design-certified for these installations in accordance with ANSI Z21.11.2. Exception: DO NOT install this appliance in a factory-built fireplace that includes instructions stating it has not been tested or should not be used with unvented gas logs.

This is an unvented gas-fired heater. It uses air (oxygen) from the room in which it is installed. Provisions for adequate combustion and ventilation air must be provided. Refer to Air for Combustion and Ventilation section on *Page 6* of this manual.

⚠ WARNING: If the information in this manual is not followed exactly, a fire or explosion may result causing property damage, personal injury or loss of life.

- Do not store or use gasoline or other flammable vapors and liquids in the vicinity of this or any other appliance.
- **WHAT TO DO IF YOU SMELL GAS**
 - Do not try to light any appliance.
 - Do not touch any electrical switch; do not use any phone in your building.
 - Immediately call your gas supplier from a neighbor's phone. Follow the gas supplier's instructions.
 - If you cannot reach your gas supplier, call the fire department.
- Installation and service must be performed by a qualified installer, service agency or the gas supplier.

TABLE OF CONTENTS

Safety.....	2	Accessories.....	38
Product Identification.....	5	Parts	39
Local Codes	5	Replacement Parts.....	43
Unpacking.....	5	Service Hints.....	43
Product Features.....	6	Technical Service	43
Air For Combustion and Ventilation.....	6	Warranty	47
Installation	8		
Power Supply and Battery Installation	15		
Operation	21		
Inspecting Burners.....	28		
Cleaning and Maintenance	28		
Specifications.....	29		
Wiring Diagram.....	30		
Troubleshooting	31		



SAFETY

⚠ WARNING: FIRE, EXPLOSION, AND ASPHYXIATION HAZARD

Improper adjustment, alteration, service, maintenance, or installation of this heater or its controls can cause death or serious injury.

Read and follow instructions and precautions in User's Information Manual provided with this heater.

⚠ WARNING: This appliance is for installation only in a solid-fuel burning masonry or UL127 factory-built fireplace or in a listed ventless firebox enclosure. It is design-certified for these installations in accordance with ANSI Z21.11.2. Exception: **DO NOT** install this appliance in a factory-built fireplace that includes instructions stating it has not been tested or should not be used with unvented gas logs.

⚠ WARNING: Vent-free products are prohibited for bedroom and bathroom installation in the Commonwealth of Massachusetts.

⚠ WARNING: This product can expose you to chemicals including Carbon Black, which is known to the State of California to cause cancer, and Carbon Monoxide, which is known to the State of California to cause birth defects or other reproductive harm. For more information go to www.P65Warnings.ca.gov

⚠ WARNING: This is an unvented gas-fired heater. It uses air (oxygen) from the room in which it is installed. Provisions for adequate combustion and ventilation air must be provided. Refer to *Air for Combustion and Ventilation* section on Page 6 of this manual.

This appliance may be installed in an aftermarket,* permanently located, manufactured (mobile) home, where not prohibited by local codes. This appliance is only for use with the type of gas indicated on the rating plate. This appliance is not convertible for use with other gases.

* Aftermarket: Completion of sale, not for purpose of resale, from the manufacturer

IMPORTANT: Read this owner's manual carefully and completely before trying to assemble, operate or service this fireplace. Improper use of this fireplace can cause serious injury or death from burns, fire, explosion, electrical shock and carbon monoxide poisoning.

Any safety screen, guard, or barrier removed for servicing an appliance must be replaced prior to operating the heater. The firescreen or guard designed for this unvented appliance must be installed prior to operation.

SAFETY

Continued

 **DANGER: Carbon monoxide poisoning may lead to death!**

Carbon Monoxide Poisoning: Early signs of carbon monoxide poisoning resemble the flu, with headaches, dizziness or nausea. If you have these signs, the fireplace may not be working properly. **Get fresh air at once!** Have fireplace serviced. Some people are more affected by carbon monoxide than others. These include pregnant women, people with heart or lung disease or anemia, those under the influence of alcohol and those at high altitudes.

Natural and Propane/LP gases are odorless. An odor-making agent is added to these gases. The odor helps you detect a gas leak. However, the odor added to the gas can fade. Gas may be present even though no odor exists.

Make certain you read and understand all warnings. Keep this manual for reference. It is your guide to safe and proper operation of this fireplace.

 **WARNING: Any change to this heater or its controls can be dangerous.**

 **WARNING: Do not use a blower insert, heat exchanger insert or other accessory not approved for use with this heater.**

 **WARNING: Do not allow fans to blow directly into the fireplace. Avoid any drafts that alter burner flame patterns. Ceiling fans can create drafts that alter burner flame patterns. Altered burner patterns can cause sooting.**

Due to high temperatures, the appliance should be located out of traffic and away from furniture and draperies.

Do not place clothing or other flammable material on or near the appliance. Never place any objects on the heater.

Heater base assembly becomes very hot when running heater.

Young children should be carefully supervised when they are in the same room with the appliance. When using the hand-held remote accessory, keep selector switch in the OFF position to prevent children from turning on burners with remote.

You must operate this heater with the fireplace screen and hood in place before running heater. The fireplace screen shall have openings for introduction of combustion air.

Keep the appliance area clear and free from combustible materials, gasoline and other flammable vapors and liquids.

Solid-fuels shall not be burned in a fireplace in which an unvented room heater is installed.

Installation and repair should be done by a qualified service person. The appliance should be inspected before use and at least annually by a professional service person. More frequent cleaning may be required due to excessive lint from carpeting, bedding material, etc. It is imperative that control compartments, burners, and circulating air passageways of the appliance be kept clean.

 **WARNING: Do not place log scraps or volcanic stone on burner.**

Children and adults should be alerted to the hazard of high surface temperature and should stay away to avoid burns or clothing ignition. Heater will remain hot for a time after shutdown. Allow surface to cool before touching.

SAFETY

Continued

- 1. WARNING: This appliance is only for use with the type of gas indicated on the rating plate. This appliance is not convertible for use with other gases.**
2. Do not place propane/LP supply tank(s) inside any structure. Locate propane/LP supply tank(s) outdoors (propane/LP units only).
 3. If you smell gas
 - shut off gas supply
 - do not try to light any appliance
 - do not touch any electrical switch; do not use any phone in your building
 - immediately call your gas supplier from a neighbor's phone. Follow the gas supplier's instructions
 - if you cannot reach your gas supplier, call the fire department
 4. This heater shall not be installed in a bedroom or bathroom.
 5. **WARNING: Before installing in a solid fuel burning fireplace, the chimney flue and firebox must be cleaned of soot, creosote, ashes and loose paint by a qualified chimney cleaner.** Creosote will ignite if highly heated. A dirty chimney flue may create and distribute soot within the house. Inspect chimney flue for damage. If damaged, repair flue and firebox before operating heater.
 6. Do not burn solid-fuel in a fireplace in which an unvented appliance is installed.
 7. If fireplace has glass doors, never operate this heater with glass doors closed. Any glass doors shall be fully opened when the appliance is in operation. If you operate heater with doors closed, heat buildup inside fireplace will cause glass to burst. Make sure there are no obstructions across openings of fireplace.
 8. To prevent the creation of soot, follow the instructions in *Cleaning and Maintenance, Page 27*.
 9. Before using furniture polish, wax, carpet cleaner or similar products, turn heater off. If heated, the vapors from these products may create a white powder residue within burner box or on adjacent walls and furniture.
 10. This heater needs fresh, outside air ventilation to run properly. This heater has an Oxygen Depletion Sensing (ODS) safety shutoff system. The ODS shuts down the heater if enough fresh air is not available. See *Air for Combustion and Ventilation, Page 6*. If heater keeps shutting off, see *Troubleshooting, Page 30*.
 11. Do not run heater
 - where flammable liquids or vapors are used or stored
 - under dusty conditions
 12. Do not use this heater to cook food or burn paper or other objects.
 13. Do not use this room heater if any part has been under water. Immediately call a qualified service technician to inspect the room heater and to replace any part of the control system and any gas control which has been under water.
 14. Do not operate heater if any log is broken. Do not operate heater if a log is chipped (dime-sized or larger).
 15. Turn appliance off and let cool before servicing, installing or repairing. Only a qualified service person should install, service or repair appliance.
 16. Make sure the remote is set to the OFF position when you are away from home for long periods of time.
 17. Remote heaters must not be connected to any external electrical source.
 18. Operating heater above elevations of 4,500 feet may cause pilot outage.
 19. To prevent performance problems, do not use propane/LP fuel tank of less than 100 lb. capacity (propane/LP units only).
 20. Provide adequate clearances around air openings.
 21. When installing as a vented appliance in a manufactured home or mobile home, the installation must conform with the Manufactured Home Construction and Safety Standard, Title 24 CFR, Part 3280, or when applicable, with Manufacture Home Installations Standard, ANSI/NCBCS A225.1/NFPZ 501A.
 22. This log heater is designed to be smokeless. If logs ever appear to smoke, turn off heater and call a qualified service person.
NOTE: *During initial operation, slight smoking could occur due to log curing and heater burning manufacturing residues.*

PRODUCT IDENTIFICATION

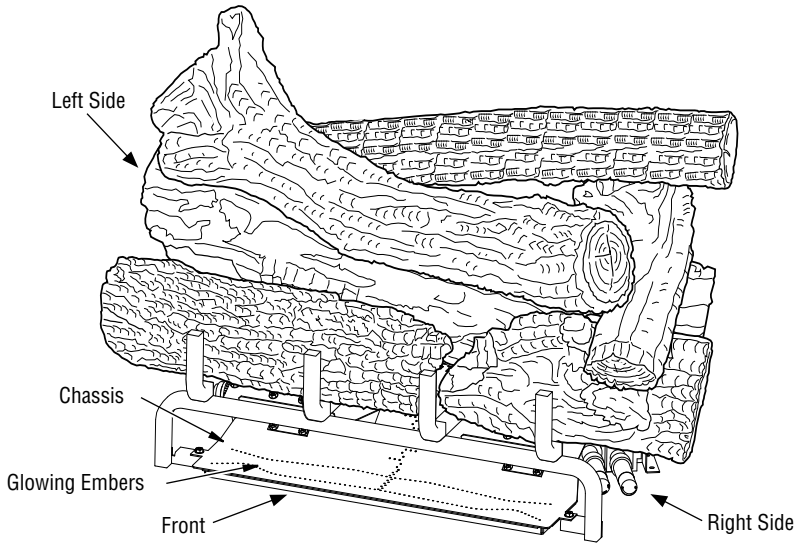

Figure 1 - Product Identification

LOCAL CODES

Install and use appliance with care. The installation must conform with local codes or in the absence of local codes, to the latest edition of The National Fuel Gas Code, ANSI Z223.1/NFPA54*.

*Available from:

American National Standards Institute, Inc.
25 West 43rd Street, 4th floor
New York, NY 10036

National Fire Protection Association, Inc.
1 Batterymarch Park
Quincy, MA 02169-7471

UNPACKING

1. Remove logs and appliance base assembly from carton(s).

NOTE: Do not pick up appliance base assembly by burners. This could damage the appliance. Always handle base assembly by grate.

2. Remove all protective packaging applied to logs and appliance for shipment.
3. Check appliance for any shipping damage. If appliance is damaged, promptly inform dealer where you purchased the appliance.

⚠ CAUTION: Do not remove the data plates from the grate assembly. The data plates contain important warranty and safety information.

COMMONWEALTH OF MASSACHUSETTS REQUIREMENTS

These appliances are approved for installation in the US state of Massachusetts if the following additional requirements are met:

- Un-vented Room Heaters shall be installed in accordance with 527 CMR 30.
 - Installation and repair must be done by a plumber or gas fitter licensed in the Commonwealth of Massachusetts.
 - The flexible gas line connector used shall not exceed 36 inches (92 centimeters) in length.
 - The individual manual shut-off must be a T-handle type valve.
 - Unvented appliances may NOT be installed in bedrooms or bathrooms.
 - A working smoke detector must be installed in the area where vent-free appliances are installed.
- Seller of unvented propane or natural gas-fired supplemental room heaters shall provide to each purchaser a copy of 527 CMR 30 upon sale of the unit.

PRODUCT FEATURES

OPERATION

This appliance is clean burning. It requires no outside venting. There is no heat loss out a vent or up a chimney. Heat is generated by both realistic flames and glowing coals. This appliance is designed for vent-free operation with flue damper closed. It has been tested and approved to the ANSI Z21.11.2 standard for unvented room heaters.

SAFETY DEVICE

This heater has a pilot with an Oxygen Depletion Sensing (ODS) safety shutoff system. The ODS/pilot is a required feature for unvented appliances. The ODS/pilot shuts off the appliance if there is not enough fresh air.

ELECTRONIC IGNITION SYSTEM

This appliance has an electronic igniter to light appliance fuel supply.

AIR FOR COMBUSTION AND VENTILATION

⚠ WARNING: This heater shall not be installed in a room or space unless the required volume of indoor combustion air is provided by the method described in the National Fuel Gas Code, ANSI Z223.1/NFPA 54, the International Fuel Gas Code, or applicable local codes. Read the following instructions to ensure proper fresh air for this and other fuel-burning appliances in your home.

Today's homes are built more energy efficient than ever. New materials, increased insulation and new construction methods help reduce heat loss in homes. Homeowners apply weather strip and caulk around windows and doors to keep the cold air out and the warm air in. During heating months, homeowners want their homes as airtight as possible.

While it is good to make your home energy efficient, your home needs to breathe. Fresh air must enter your home. All fuel-burning appliances need fresh air for proper combustion and ventilation.

Exhaust fans, some fireplaces, clothes dryers and some fuel-burning appliances draw air from the house to operate. You must provide adequate fresh air for these appliances. That will ensure proper venting of vented fuel-burning appliances.

PROVIDING ADEQUATE VENTILATION

The following are excerpts from *National Fuel Gas Code, ANSI Z223.1/NFPA 54, Air for Combustion and Ventilation*.

All spaces in homes fall into one of the three following ventilation classifications:

1. Unusually Tight Construction
2. Unconfined Space
3. Confined Space

The information on **Pages 6-8** will help you classify your space and provide adequate ventilation.

Unusually Tight Construction

The air that leaks around doors and windows may provide enough fresh air for combustion and ventilation. However, in buildings of unusually tight construction, you must provide additional fresh air.

Unusually tight construction is defined as construction where:

- a. walls and ceilings exposed to the outside atmosphere have a continuous water vapor retarder with a rating of one perm (6×10^{-11} kg per pa-sec-m²) or less with openings gasketed or sealed **and**
- b. weather stripping has been added on openable windows and doors **and**
- c. caulking or sealants are applied to areas such as joints around window and door frames, between sole plates and floors, between wall-ceiling joints, between wall panels, at penetrations for plumbing, electrical and gas lines and at other openings.

If your home meets all three criteria above, you must provide additional fresh air. See [Ventilation Air From Outdoors, Page 8](#).

If your home does not meet all three criteria above, proceed to [Determining Fresh-Air Flow For Heater Location, Page 7](#).

Confined and Unconfined Space

The National Fuel Gas Code, ANSI Z223.1/NFPA54 allows two methods for determining whether the space in which the heater is being installed is confined or unconfined space.

AIR FOR COMBUSTION AND VENTILATION

Continued

The standard method defines a confined space as a space whose volume is less than 50 cubic feet per 1,000 Btu/hr (4.8 m³ per kw) of the aggregate input rating of all appliances installed in that space and an unconfined space as a space whose volume is not less than 50 cubic feet per 1,000 Btu/hr (4.8 m³ per kw) of the aggregate input rating of all appliances installed in that space. Rooms communicating directly with the space in which the appliances are installed*, through openings not furnished with doors, are considered a part of the unconfined space.

Where the air infiltration rate of a structure is known, the Known Air Infiltration Rate Method may be used. Follow The National Fuel Gas Code, ANSI Z223.1/NFPA 54 to use this method to determine if the space is confined or unconfined.

* Adjoining rooms are communicating only if there are doorless passageways or ventilation grills between them.

DETERMINING FRESH-AIR FLOW FOR HEATER LOCATION

Determining if You Have a Confined or Unconfined Space Using the Standard Method

Use this work sheet to determine if you have a confined or unconfined space.

Space: Includes the room in which you will install fireplace plus any adjoining rooms with doorless passageways or ventilation grills between the rooms.

1. Determine the volume of the space (length x width x height).

Length x Width x Height = _____ cu. ft. (volume of space)

Example: Space size 20 ft. (length) x 16 ft. (width) x 8 ft. (ceiling height) = 2560 cu. ft. (volume of space)

If additional ventilation to adjoining room is supplied with grills or openings, add the volume of these rooms to the total volume of the space.

2. Multiply the space volume by 20 to determine the maximum Btu/Hr the space can support.

_____ (volume of space) x 20 = (Maximum Btu/Hr the space can support)

Example: 2560 cu. ft. (volume of space) x 20 = 51,200 (maximum Btu/Hr the space can support)

3. Add the Btu/Hr of all fuel-burning appliances in the space.

Vent-free fireplace	_____	Btu/Hr
Gas water heater*	_____	Btu/Hr
Gas furnace	_____	Btu/Hr
Vented gas heater	_____	Btu/Hr
Gas fireplace logs	_____	Btu/Hr
Other gas appliances*	+ _____	Btu/Hr
Total	= _____	Btu/Hr

* Do not include direct-vent gas appliances. Direct-vent draws combustion air from the outdoors and vents to the outdoors.

Example:

Gas water heater	_____	40,000	Btu/Hr	
Vent-free fireplace	+	_____	33,000	Btu/Hr
Total	=	_____	73,000	Btu/Hr

4. Compare the maximum Btu/Hr the space can support with the actual amount of Btu/Hr used.

_____ Btu/Hr (maximum the space can support)

_____ Btu/Hr (actual amount used)

Example: 51,200 Btu/Hr (maximum the space can support)

73,000 Btu/Hr (actual amount of Btu/Hr used)

The space in the above example is a confined space because the actual Btu/Hr used is more than the maximum Btu/Hr the space can support. You must provide additional fresh air. Your options are as follows:

- Rework worksheet, adding the space of an adjoining room. If the extra space provides an unconfined space, remove door to adjoining room or add ventilation grills between rooms. See *Ventilation Air From Inside Building, Page 8*.
- Vent room directly to the outdoors. See *Ventilation Air From Outdoors, Page 8*.
- Install a lower Btu/Hr appliance, if lower Btu/Hr size makes room unconfined.

If the actual Btu/Hr used is less than the maximum Btu/Hr the space can support, the space is an unconfined space. You will need no additional fresh air ventilation.

⚠ WARNING: If the area in which the heater may be operated does not meet the required volume for indoor combustion air, combustion and ventilation air shall be provided by one of the methods described in the National Fuel Gas Code, ANSI Z223.1/ NFPA 54, the International Fuel Gas Code, or applicable local codes.

AIR FOR COMBUSTION AND VENTILATION

Continued

VENTILATION AIR

Ventilation Air From Inside Building

This fresh air would come from an adjoining unconfined space. When ventilating to an adjoining unconfined space, you must provide two permanent openings: one within 12" of the ceiling and one within 12" of the floor on the wall connecting the two spaces (see options 1 and 2, **Figure 2**). You can also remove door into adjoining room (see option 3, **Figure 2**). Follow the *National Fuel Gas Code, ANSI Z223.1/NFPA 54, Air for Combustion and Ventilation* for required size of ventilation grills or ducts.

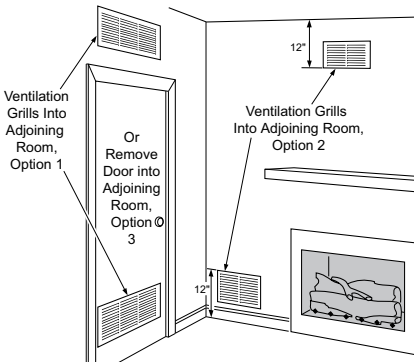

Figure 2 - Ventilation Air from Inside Building

Ventilation Air From Outdoors

Provide extra fresh air by using ventilation grills or ducts. You must provide two permanent openings: one within 12" of the ceiling and one within 12" of the floor. Connect these items directly to the outdoors or spaces open to the outdoors. These spaces include attics and crawl spaces. Follow the *National Fuel Gas Code, ANSI Z223.1/NFPA 54, Air for Combustion and Ventilation* for required size of ventilation grills or ducts.

IMPORTANT: Do not provide openings for inlet or outlet air into attic if attic has a thermostat-controlled power vent. Heated air entering the attic will activate the power vent.

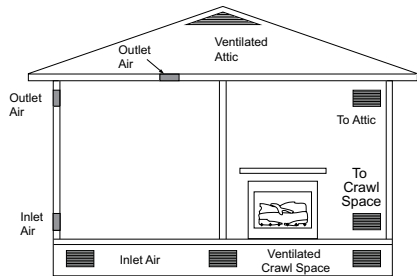

Figure 3 - Ventilation Air from Outdoors

INSTALLATION

NOTICE: This appliance is intended for supplemental heating. Use this appliance along with your primary heating system. Do not install this appliance as your primary heat source. If you have a central heating system, you may run system's circulating blower while using appliance. This will help circulate the heat throughout the house. In the event of a power outage, you can use this appliance as your primary heat source.

WARNING: A qualified service person must install appliance. Follow all local codes.

WARNING: Any outside air ducts and/or ash dumps in the fireplace shall be permanently closed at time of appliance installation.

WARNING: Seal any fresh air vents or ash clean-out doors located on floor or wall of fireplace. If not, drafting may cause pilot outage or sooting. Use a heat-resistant sealant. Do not seal chimney flue damper.

WARNING: Before installing in a solid fuel-burning fireplace, the chimney flue and firebox must be cleaned of soot, creosote, ashes and loose paint by a qualified chimney cleaner. Creosote will ignite if highly heated. A dirty chimney flue may create and distribute soot within the house. Inspect chimney and firebox flue for damage. If damaged, repair flue and firebox before operating appliance.

INSTALLATION

Continued

⚠ WARNING: Never install the appliance

- in a bedroom or bathroom
- in a recreational vehicle
- where curtains, furniture, clothing or other flammable objects are less than 36" from front, 42" from top of appliance; for side clearances see *Figure 4, Page 10*
- in high traffic areas
- in windy or drafty areas

⚠ CAUTION: This appliance creates warm air currents. These currents move heat to wall surfaces next to heater. Installing heater next to vinyl or cloth wall coverings or operating heater where impurities (such as, but not limited to, tobacco smoke, aromatic candles, cleaning fluids, oil or kerosene lamps, etc.) in the air exist, may discolor walls or cause odors.

⚠ WARNING: Make sure the selector switch is in the OFF position before installing heater.

NOTICE: State or local codes may only allow operation of this appliance in a vented configuration. Check your state or local codes.

IMPORTANT: Vent-free appliances add moisture to the air. Although this is beneficial, installing appliance in rooms without enough ventilation air may cause mildew to form from too much moisture. See *Air for Combustion and Ventilation, Page 6*.

CHECK GAS TYPE

Use the correct type of gas (natural or propane/LP). If your gas supply is not the correct gas type, do not install appliance. Call the dealer where you purchased the appliance for proper type appliance.

⚠ WARNING: This appliance is equipped for either natural gas or propane/LP gas but not both. Gas type is indicated on the rating plate. Field conversion is not permitted.

INSTALLATION AND CLEARANCES FOR VENT-FREE OPERATION

⚠ WARNING: Maintain the minimum clearances. If you can, provide greater clearances from floor, ceiling and adjoining wall.

MINIMUM FIREPLACE CLEARANCE TO COMBUSTIBLE MATERIALS

Side Wall 16", Ceiling 42"
Floor 5", Front: 36"

LOG SIZING REQUIREMENTS

Log Size	Minimum Firebox Size			
	Height	Depth	Front Width	Rear* Width
LMF24GTA/B LMF24MOA/B	29"	15.5"	32.5"	22.75"
LMF30GTA/B LMF30MOA/B	29"	15.5"	39"	26.75"
LMF36GTA/B LMF36MOA/B	29"	20"	47"	33"

* Also approved for use in VEGA42 and VALIANT42 SERIES fireplaces.

Carefully follow the instructions below. This will ensure safe installation into a masonry, UL127-listed manufactured fireplace or listed vent-free firebox.

Minimum Clearances For Side Combustible Material, Side Wall and Ceiling

A. Clearances from the side of the fireplace cabinet to any combustible material and wall should follow diagram in *Figure 4, Page 10*.

Example: The face of a mantel, bookshelf, etc. is made of combustible material and protrudes 3-1/2" from the wall. This combustible material must be 4" from the side of the fireplace cabinet (see *Figure 4, Page 10*).

INSTALLATION

Continued

NOTE: When installing your gas logs into a manufactured firebox, follow firebox manufacturer's instructions for minimum clearances to combustible materials.

- B. Clearances from the top of the fireplace opening to the ceiling should not be less than 42".

Maintain adequate clearances for accessibility for purposes of servicing and proper operation.

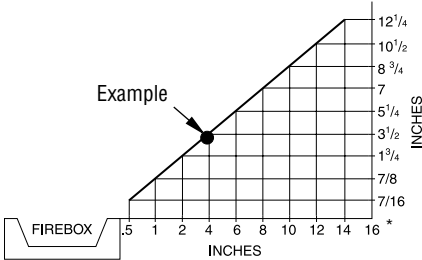

*Minimum 16" from Side Wall

Figure 4 - Minimum Clearance for Combustible to Wall

Minimum Noncombustible Material Clearances

If Not Using Mantel

NOTE: If using a mantel proceed to If Using Mantel. If not using a mantel, follow these instructions.

You must have noncombustible material(s) above the fireplace opening. Noncombustible materials (such as slate, marble, tile, etc.) must be at least 1/2" thick. With sheet metal, you must have noncombustible material behind it. Noncombustible material must extend at least 8" up (for all models). If noncombustible material is less than 12", you must install the fireplace hood accessory (24" and 30" Models Only). See **Figure 5** for minimum clearances.

Noncombustible Material Distance (A)	Requirements for Safe Installation
12" or more	Noncombustible material OK.
Between 8" and 12"	Install fireplace hood accessory (GA6050 - see <u>Accessories, Page 38</u>).
Less than 8"	Noncombustible material must be extended to at least 8". See <u>Between 8" and 12"</u> , above. If you cannot extend material, you must operate appliance with flue damper open.

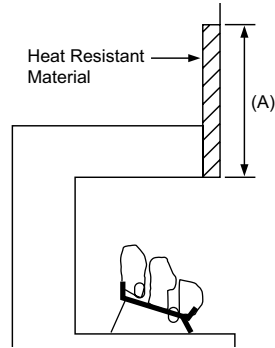

Figure 5 - Heat Resistant Material (Slate, Marble, Tile, etc.) Above Fireplace

If Using Mantel

You must have noncombustible material(s) above the fireplace opening. Noncombustible materials (such as slate, marble, tile, etc.) must be at least 1/2" thick. With sheet metal, you must have noncombustible material behind it. Noncombustible material must extend at least 8" up (for all models). If noncombustible material is less than 12", you must install the fireplace hood accessory. Even if noncombustible material is more than 12", you may need the hood accessory to deflect heat away from your mantel shelf. See **Figures 5-7, Pages 10-11**, for minimum clearances.

INSTALLATION

Continued

MANTEL CLEARANCES

In addition to meeting noncombustible material clearances, you must also meet required clearances between fireplace opening and mantel shelf. If you do not meet the clearances listed below, you will need a hood.

Determining Minimum Mantel Clearance

If you meet minimum clearance between mantel shelf and top of fireplace opening, a hood is not required (see **Figure 6**).

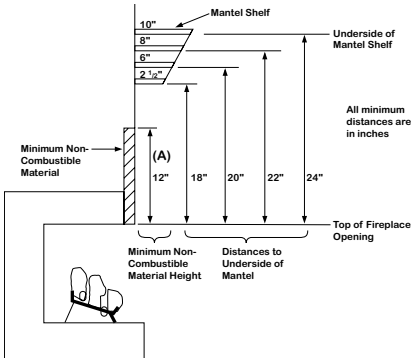

Figure 6 - Minimum Mantel Clearances Without Using Hood

Determining Minimum Mantel Clearance When Using a Hood

If minimum clearances in **Figure 6**, are not met, you must have a hood. When using a hood there are still certain minimum mantel clearances required. Follow minimum clearances shown in **Figure 7**, when using hood.

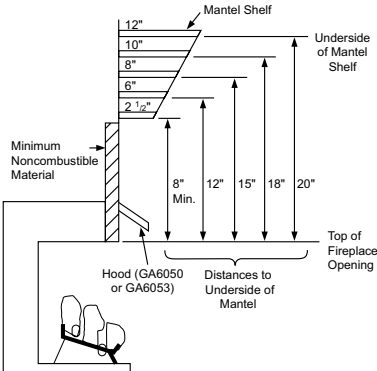

Figure 7 - Minimum Mantel Clearances When Using Hood

Minimum clearance requirements include any projections such as shelves, window sills, mantels, etc. above the appliance.

NOTICE: Surface temperatures of adjacent walls and mantels become hot during operation. Walls and mantels above the firebox may become hot to the touch. If installed properly, these temperatures meet the requirement of the national product standard. Follow all minimum clearances shown in this manual.

NOTICE: If your installation does not meet the minimum clearances shown, you must do one of the following:

- operate the logs only with the flue damper open
- raise the mantel to an acceptable height
- remove the mantel

FLOOR CLEARANCES

- A. If installing appliance on the floor level, you must maintain the minimum distance of 14" to combustibles (see **Figure 8**).
- B. If combustible materials are less than 14" to the fireplace, you must install appliance at least 5" above the top surface of combustible flooring including tile and carpet (see **Figure 9**).

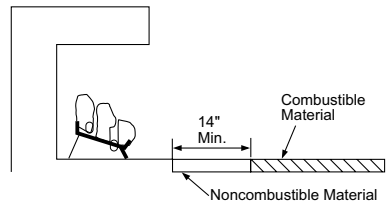

Figure 8 - Minimum Fireplace Clearances If Installed at Floor Level

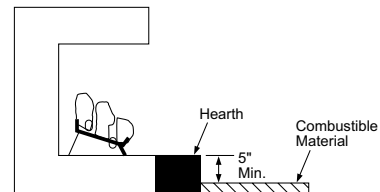

Figure 9 - Minimum Fireplace Clearances Above Combustible Flooring

INSTALLATION

Continued

INSTALLING APPLIANCE BASE ASSEMBLY

⚠ WARNING: You must secure this heater to fireplace floor. If not, heater will move when you adjust controls. Moving heater may cause a gas leak or log misplacement.

⚠ WARNING: If installing in a sunken fireplace, special care is needed. You must raise the fireplace floor to allow access to heater control panel. This will ensure adequate air flow and guard against sooting and controls being damaged. Raise fireplace floor with noncombustible material. Make sure material is secure.

⚠ CAUTION: Do not pick up heater base assembly by burners. This could damage heater. Only handle base assembly by grates.

IMPORTANT: Make sure the appliance burners are level.

Installation Items Needed

- hardware package (provided with appliance)
- approved flexible gas hose and fittings provided (if allowed by local codes)
- sealant (resistant to propane/LP gas, not provided)
- electric drill with 3/16" masonry drill bit

NOTE: Install optional MRC Series receiver and hand-held remote control kit (see *Accessories, Page 38*) before installing gas log appliance. See installation instructions included with the kit.

1. Apply pipe joint sealant lightly to male threads of the 3/8 NPT side of gas fitting elbow (provided) and connect to inlet side of gas control. Remove gas fitting from flexible gas hose (provided) before connecting to elbow (see *Figure 10*).
2. Position appliance base assembly in fireplace.

3. Mark screw locations through holes in front panel of base (see *Figure 11*). If installing in a brick-bottom fireplace, mark screw locations in mortar joint of bricks.
4. Remove appliance base from fireplace.
5. Drill holes at marked locations using 3/16" drill bit.
6. Attach base, through holes in back side panels of base, to fireplace floor using masonry screws provided in hardware package (see *Figure 11*).
7. Connect to gas supply. See *Connecting To Gas Supply, Page 13*.

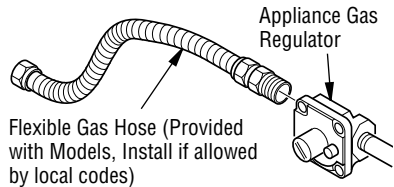

Figure 10 - Attaching Flexible Gas Hose to Appliance Gas Regulator

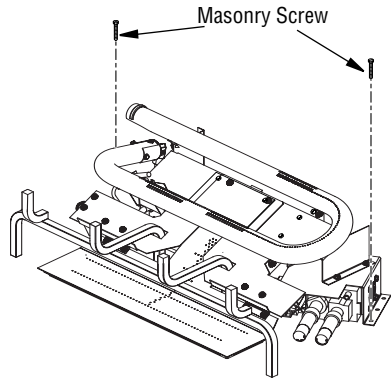

Figure 11 - Attaching Base to Fireplace Floor

INSTALLATION

Continued

CONNECTING TO GAS SUPPLY

⚠ WARNING: This appliance requires a 3/8" NPT (National Pipe Thread) inlet connection to the pressure regulator.

⚠ WARNING: A qualified service person must connect appliance to gas supply. Follow all local codes.

⚠ CAUTION: Never connect propane/LP fireplace directly to the propane/LP supply. This heater requires an external regulator (not supplied). Install the external regulator between the heater and propane/LP supply.

⚠ WARNING: Never connect this appliance to private (non-utility) gas wells. This gas is commonly known as wellhead gas and does not have odorants and may have impurities, and variations in BTU content. The use of well-head gas will void the manufacturer's warranty to this appliance.

⚠ CAUTION: Use only new, black iron or steel pipe. Internally-tinned copper tubing may be used in certain areas. Check your local codes. Use pipe of 1/2" diameter or greater to allow proper gas volume to heater. If pipe is too small, undue loss of volume will occur.

⚠ WARNING: Use pipe joint sealant that is resistant to liquid petroleum (LP) gas.

Installation Items Needed

Before installing appliance, make sure you have the items listed below.

- external regulator (supplied by installer)
- piping (check local codes)
- sealant (resistant to propane/LP gas)
- equipment shutoff valve *
- test gauge connection *
- sediment trap
- tee joint
- pipe wrench
- approved flexible gas line with gas connector (if allowed by local codes) (not provided)

* An equipment shutoff valve with 1/8" NPT tap is an acceptable alternative to test gauge connection.

For propane/LP units, the installer must supply an external regulator. The external regulator will reduce incoming gas pressure. You must reduce incoming gas pressure to between 11" and 14" of water. If you do not reduce incoming gas pressure, appliance regulator damage could occur. Install external regulator with the vent pointing down as shown in *Figure 12, Page 13*. Pointing the vent down protects it from freezing rain or sleet.

Installation must include an equipment shutoff valve, union and plugged 1/8" NPT tap. Locate NPT tap within reach for test gauge hook up. NPT tap must be upstream from appliance (see *Figure 13, Page 14*).

IMPORTANT: Install equipment shutoff valve in an accessible location. The equipment shutoff valve is for turning on or shutting off the gas to the appliance.

Check your building codes for any special requirements for locating equipment shutoff valve to appliances.

Apply pipe joint sealant lightly to male NPT threads. This will prevent excess sealant from going into pipe. Excess sealant in pipe could result in clogged appliance valves.

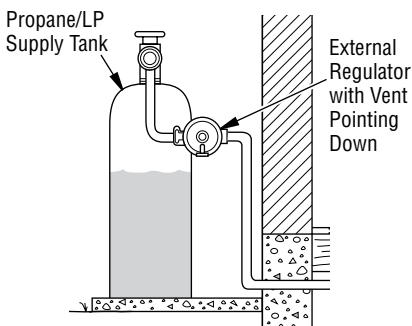

Figure 12 - External Regulator With Vent Pointing Down

INSTALLATION

Continued

PROPANE/LP From External Regulator
(11" W.C.** to 14" W.C. Pressure)

NATURAL From Gas Meter (5" W.C.**
to 10.5" W.C. Pressure)

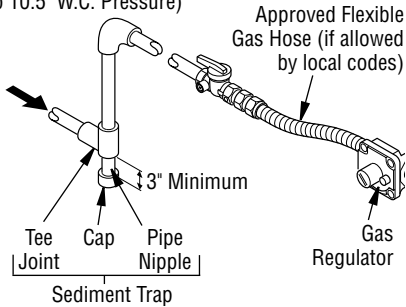

** Minimum inlet pressure for purpose of input adjustment.

Figure 13 - Gas Connection

We recommend that you install a sediment trap in supply line as shown in **Figure 13**. Locate sediment trap where it is within reach for cleaning. Install in piping system between fuel supply and appliance. Locate sediment trap where trapped matter is not likely to freeze. A sediment trap traps moisture and contaminants. This keeps them from going into appliance controls. If sediment trap is not installed or is installed wrong, appliance may not run properly.

CAUTION: Avoid damage to gas control. Hold gas control with wrench when connecting it to gas piping and/or fittings.

CHECKING GAS CONNECTIONS

WARNING: Test all gas piping and connections, internal and external to unit, for leaks after installing or servicing. Correct all leaks at once.

WARNING: Never use an open flame to check for a leak. Apply a noncorrosive leak detection fluid to all joints. Bubbles forming show a leak. Correct all leaks at once.

CAUTION: Make sure external regulator has been installed between propane/LP supply and appliance. See guidelines under Connecting to Gas Supply, Page 13.

PRESSURE TESTING GAS SUPPLY PIPING SYSTEM

The appliance and its appliance main gas valve must be disconnected from the gas supply piping system during any pressure testing of that system at test pressures **in excess of** 1/2 psi (3.5 kPa).

The appliance must be isolated from the gas supply piping system by closing its equipment shutoff valve during any pressure testing of the gas supply piping system at test pressures **equal to or less than** 1/2 psi (3.5 kPa).

Test Pressures In Excess Of 1/2 PSIG (3.5 kPa)

1. Disconnect appliance with its appliance main gas valve (control valve) and equipment shutoff valve from gas supply piping system. Pressures in excess of 1/2 psig (3.5 kPa) will damage appliance regulator.
2. Cap off open end of gas pipe where equipment shutoff valve was connected.
3. Pressurize supply piping system by either opening propane/LP supply tank valve for propane/LP gas or opening main gas valve located on or near gas meter for natural gas or using compressed air.
4. Check all joints of gas supply piping system. Apply noncorrosive leak detection fluid to all joints. Bubbles forming show a leak.
5. Correct all leaks at once.
6. Reconnect appliance and equipment shutoff valve to gas supply. Check reconnected fittings for leaks.

Test Pressures Equal To or Less Than 1/2 PSIG (3.5 kPa)

1. Close equipment shutoff valve (*see Figure 14*).
2. Pressurize supply piping system by either opening propane/LP supply tank valve for propane/LP gas or opening main gas valve located on or near gas meter for natural gas or using compressed air.
3. Check all joints from gas meter to equipment shutoff valve for natural gas or propane/LP supply to equipment shutoff valve for propane/LP (*see Figure 15 or Figure 16*). Apply noncorrosive leak detection fluid to all joints. Bubbles forming show a leak.
4. Correct all leaks at once.

INSTALLATION

Continued

PRESSURE TESTING APPLIANCE GAS CONNECTIONS

1. Open equipment shutoff valve (see **Figure 14**).
2. Open main gas valve located on or near gas meter for natural gas or open propane/LP supply tank valve.
3. Make sure control knob of appliance is in the OFF position.
4. Check all joints from gas meter to equipment shutoff valve for natural gas or propane/LP supply to equipment shutoff valve for propane/LP (see **Figure 15**, or **Figure 16**). Apply noncorrosive leak detection fluid to all joints. Bubbles forming show a leak.
5. Correct all leaks at once.
6. Light appliance (see **Operation, Page 20**). Check all other internal joints for leaks.
7. Turn off appliance (see **To Turn Off Gas to Appliance, Page 20**) for Remote models.

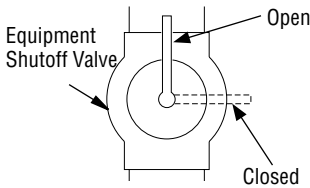

Figure 14 - Equipment Shutoff Valve

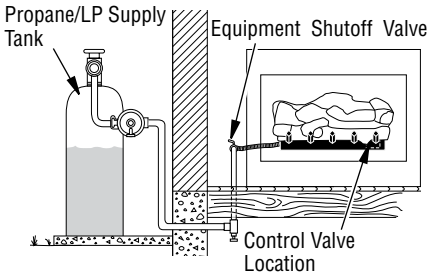

Figure 15 - Checking Gas Joints (Propane/LP Only)

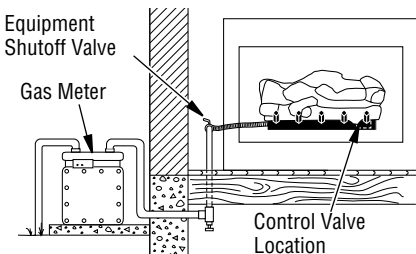

Figure 16 - Checking Gas Joints (Natural Gas Only)

POWER SUPPLY AND BATTERY INSTALLATION

It is helpful to have a flashlight so you can see the connections as described below. Locate the battery power supply. It is the black box with the red and black wires. Locate the control module (see **Figure 17**). Connect the battery power supply to the control module by plugging the battery power supply to the mating receptacle on the control module. The receptacle is located on the side of the black control module next to the word "BATT" which is molded in the control module's black housing (see **Figure 17**). Be certain to push the plug fully into the receptacle. Install batteries in the battery power supply and hand held remote control. Place the battery box so it is located away from the burner as much as possible towards the back left side of the fireplace floor.



Connect Battery Plug Here

Figure 17 - Control Module

INSTALLATION

Continued

INSTALLING LOGS, EMBERS AND VOLCANIC STONE

⚠ WARNING: Failure to position the parts in accordance with these diagrams or failure to use only parts specifically approved with this heater may result in property damage or personal injury.

⚠ CAUTION: Do not remove the data plates attached to the heater base assembly. The data plates contain important safety and warranty information.

⚠ WARNING: After installation and periodically thereafter, check to ensure that no flame comes in contact with any log. With the heater set to High, check to see if flame contact any log. If so, reposition logs according to the log installation instructions in this manual. Flames contacting logs will create soot.

LOG PLACEMENT

It is very important to install these logs exactly as instructed. Do not modify logs. Only use logs supplied with appliance or for MF models, as identified for use with the appliance as shown in **Figure 21**.

NOTE: Each log includes an identifying number cast in the log. Look at each log when placing them on the burner system to be certain it is correct.

Magniflame SERIES BURNER SYSTEM-LOG COMPATIBILITY CHART

Burner System Model	Refractory Concrete Logs For Use With This Burner System
MNF24INE MNF24IPE	LMF24GTA/B LMF30GTA/B LMF24MOA/B LMF30MOA/B
MNF30INE MNF30IPE	LMF36GTA/B LMF36MOA/B

Figure 21 - Magniflame Log Compatibility Chart

1. Find the right front log (LMF24GTA/B or LMF24MOA/B models: D-061, LMF30GTA/B or LMF30MOA/B models: D-019, LMF36GTA/B or LMF36MOA/B models: D-027). See **Figures 22, 22A, 22B, and 22C** for reference. The log has a rectangular shape on the bottom that fits against the lip on the black metal base, the square grate, and the round tube burner. Slide the log in place as shown in Figures.

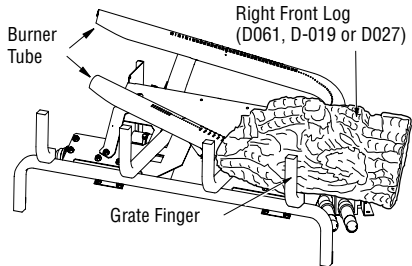

Figure 22 - Installing Right Front Log



Figure 22A - Installing Right Front Log, Top View

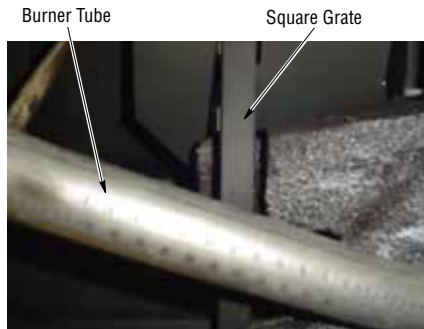

Figure 22B - Installing Right Front Log, Top View

INSTALLATION

Continued

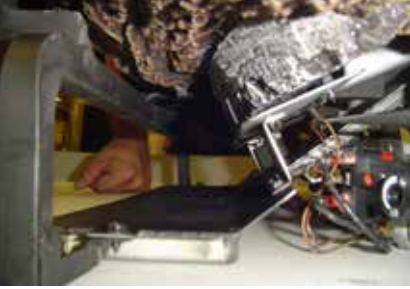

Figure 22C - Installing Right Front Log, Side View



Vertical Portion of Burner Tube

Figure 23B - Installing Back Left Log (D-018) Rear View

2. Find the back left log (LMF24GTA/B or LMF24MOA/B models: D-060, LMF30GTA/B or LMF30MOA/B models: D-018, LMF36GTA/B or LMF36MOA/B models: D-026). See **Figures 23, 23A, and 23B**. **Figure 23A** shows how the log must fit against the end of the burner. **Figure 23B** shows how the notch in log fits against the vertical portion of the burner tube. Place this log on the base assembly by inserting it from the left side as shown in **Figure 23**. You will need to twist the log slightly to get it to fit against the burners properly. It will rest even with the back edge of the pan.
3. Find the front left log (LMF24GTA/B or LMF24MOA/B models: D-059, LMF30GTA/B or LMF30MOA/B models: D-017, LMF36GTA/B or LMF36MOA/B models: D-025).

See **Figures 24, 24A, and 24B**. The log has a rectangular stand off on the bottom that fits against the lip on the black metal base as shown in **Figure 24A**. The bottom of this log has a slot that fits over the second bar on the grate as shown in **Figure 24B, Page 17**. Place the log on the base assembly as shown in figures.

4. Find the charred log (D-020). See **Figures 25, 25A, and 25B**. The log has a slot in the bottom that fits over the square grate and rests against the burner tube as shown in **Figure 25**. Place this log on the base as shown in figures.

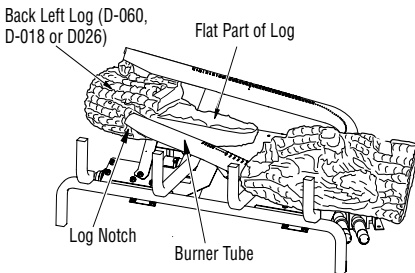

Figure 23 - Installing Back Left Log

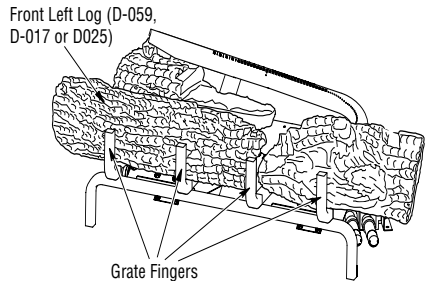

Figure 24 - Installing Front Left Log



Figure 23A - Installing Back Left Log



Figure 24A - Installing Front Left Log Side View

INSTALLATION

Continued



Grate Finger

Log Slot

Figure 24B - Installing Front Left Log

- Find the middle split log (LMF24GTA/B or LMF24MOA/B models: D-063, LMF30GTA/B or LMF30MOA/B models: D-021, LMF36GTA/B or LMF36MOA/B models: D-028).

See **Figures 26 and 26A**. The split side of the log faces forward. The log has a notch that fits around the burner tube on the right side. The left side of the burner tube fits into the notch on the back side of this log. The log is placed properly when it sits parallel to the tube burner and the square peg is pointing up. See figures for reference.

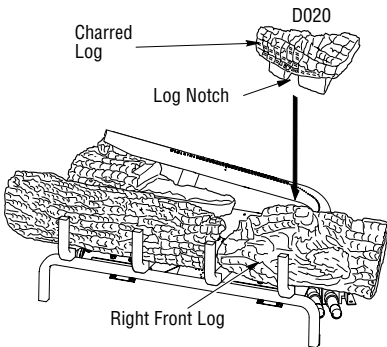
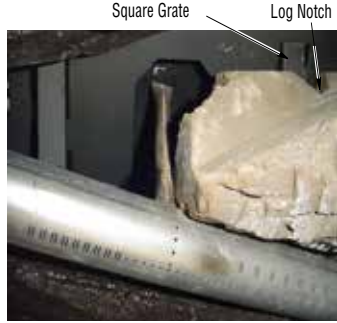

Figure 25 - Installing Charred Log



Square Grate

Log Notch

Figure 25B - Installing Charred Log Top Side View

- Find the right split crossover log (D-022). The bottom of the log has a rectangular stand off that fits in the slots on the right side of the front right log and the middle split log. Place this log as shown in **Figure 27**.

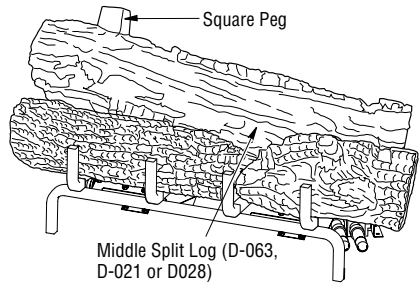

Square Peg

Middle Split Log (D-063, D-021 or D028)

Figure 26 - Installing Middle Split Log (D-021)



Figure 25A - Installing Charred Log Top View

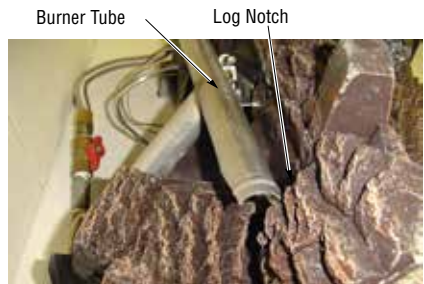

Burner Tube

Log Notch

Figure 26A - Installing Middle Split Log Rear Top Side View

INSTALLATION

Continued

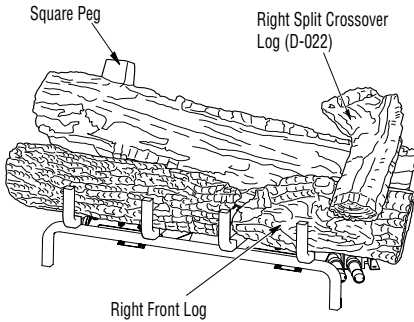

Figure 27 - Installing Right Split Crossover Log

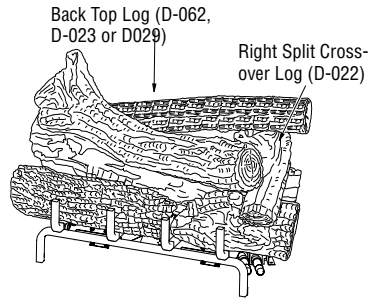

Figure 29 - Installing Back Top Log and Final Assembly

- For GTA/GTB logs, find the front top log (D-024). See **Figure 28**. The left end of this log has a square hole that fits over a square peg that is on the top of the middle split log. The right end of this log rests behind the knot on the top of the front right log.

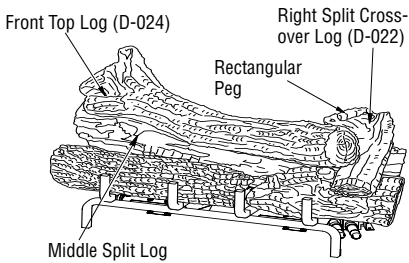

Figure 28 - Installing Large Middle Log



Figure 29A - Installing Back Top Log, Top View

- Find the back top log (LMF24GTA/B or LMF24MOA/B models: D-062, LMF30GTA/B or LMF30MOA/B models: D-023, LMF36GTA/B or LMF36MOA/B models: D-029). See **Figures 29, and 29A**. The left end of this log has a round hole that fits over the round peg that is on the top of the back left log. The right end of this log has a rectangular hole that fits over the rectangular peg on the top of the right crossover log.



Figure 30 - Installing Small Left Hand And Right Hand Logs

For MOA/B logs only, follow steps 9 and 10.

- Install the small Left Top Log D080 as shown in **Figure 30** by mating the rectangular peg and notch.
- Install the small Right Top Log D081 as shown in **Figure 30**.

INSTALLATION

Continued

Two ember materials are supplied with this log set. Platinum Bright Embers give a bright glow appearing as hot coals. Should embers need replacing, see *Accessories, Page 37*.

EMBER PLACEMENT

- **Platinum Bright Ember placement.** Add embers to front, flat burner. Gently remove embers from bag. Separate pieces of ember material and place on surface of flat burner just behind horizontal ports as shown in *Figure 31*.
- **Glowing Embers placement.** Place glowing embers material on front flat burner in areas away from ports as shown in *Figure 32*.

WARNING: ALL PREVIOUSLY APPLIED LOOSE MATERIAL MUST BE REMOVED PRIOR TO REAPPLICATION.

WARNING: Do not use any other ember material not supplied with this unit.

WARNING: Do not operate unit without ember material correctly in place as shown in *Figures 31 and 32*. Do NOT place ember material anywhere else on the unit. Use only ember material supplied with unit. Excessive or incorrectly placed ember material may produce carbon monoxide or soot. If replacement embers are needed, the replacement embers must be purchased from IHP. See *Page 39* for part numbers.

VOLCANIC STONE PLACEMENT

- Add Volcanic Stone; Volcanic Stone may cover 1/2 inch of the front burner (flat metal ember pan burner) but shall not be allowed to come in contact with either the burner ports or flame around base of appliance if desired. **DO NOT place rock or additional logs on front burner or on logs except as directed above.** Placing any material on unit other than ember material on front burner may result in production of carbon monoxide or soot. A switch log is included with each log set. This log is designed to house a switch on remote ready models. On variable remote models, this switch is not needed. The log can be placed on the floor of the fireplace to enhance the look of the log set. Use Volcanic Stone to hide wires from switch/log to control valve. Place switch/log so the switch is easy to access.



Figure 31 - Platinum Bright Embers



Figure 32 - Placement of Glowing Embers (shown with Platinum Bright Embers)

OPERATION

NOTICE: During initial operation of new appliance, burning logs will give off a paper-burning smell. Orange flame will also be present. Open damper or window to vent smell. This will only last a few hours.

⚠ WARNING:

- If fireplace has glass doors, never operate this appliance with glass doors closed. If you operate appliance with doors closed, heat buildup inside fireplace will cause glass to burst. Make sure there are no obstructions across openings of fireplace.
- You must operate this appliance with a fireplace screen in place. Make sure fireplace screen is closed before running appliance.

⚠ WARNING: Damper handle will be hot if appliance has been running.

⚠ CAUTION: Do not try to adjust heating levels by using the equipment shutoff valve.

FOR YOUR SAFETY READ BEFORE LIGHTING

⚠ WARNING: If you do not follow these instructions exactly, a fire or explosion may result causing property damage, personal injury or loss of life.

- A. This appliance is equipped with an ignition device which automatically lights the pilot. Do not light pilot by hand.

- B. **BEFORE LIGHTING** smell all around the appliance area for gas. Be sure to smell next to the floor because some gas is heavier than air and will settle on the floor.

WHAT TO DO IF YOU SMELL GAS

- Do not try to light any appliance.
 - Do not touch any electric switch; do not use any phone in your building.
 - Immediately call your gas supplier from a neighbor's phone. Follow the gas supplier's instructions.
 - If you cannot reach your gas supplier, call the fire department.
- C. Do not use this appliance if any part has been under water. Immediately call a qualified service technician to inspect the appliance and to replace any part of the control system and any gas control which has been under water.

LIGHTING INSTRUCTIONS

1. STOP! Read the safety information.
2. Make sure equipment shutoff valve is fully open.
3. Press any button on the remote to power the remote on. Press the MODE zone or the MODE/SET Button to start the unit. You will hear a beep from the control module and the pilot will start to light the unit.

NOTE: You may be running this appliance for the first time after hooking up to gas supply. If so, you may have to restart the unit several of times to allow the air to bleed from the system.

TO TURN OFF GAS TO APPLIANCE

1. Once you have activated the screen press the MODE Zone or MODE/SET Button until you see OFF.
2. Close equipment shutoff valve.

OPERATION

Continued

REMOTE CONTROL OPERATION

BASIC CONSTRUCTION

- Touch-Screen LCD and three push buttons will allow input from users.
- LCD screen will provide system status and input feedback to user.
- Backlight will illuminate LCD screen for 5 seconds after any user input – the 1st touch of the LCD screen will only illuminate the backlight (will not respond to associated zone function). To activate any command, the backlight for the screen must be on and the command must be touched before the backlight goes off.
- Powered via four AAA sized batteries (6V nominal) with LOW BATTERY INDICATOR (5.0V).

Touch-Screen LCD and Button Layout (Not to scale)

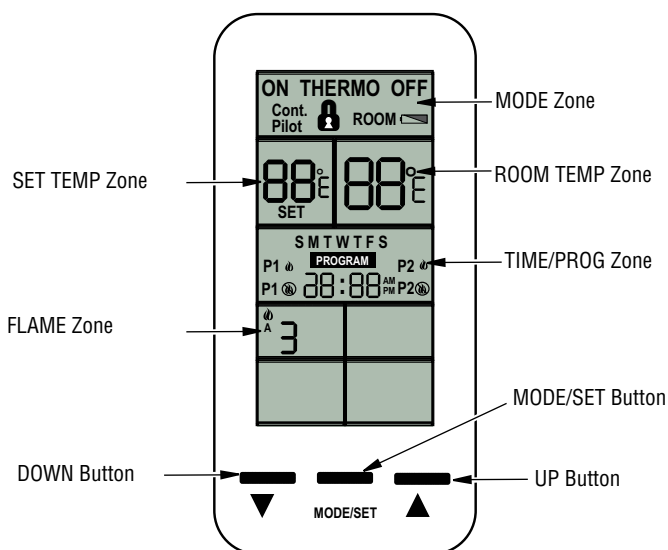

Figure 33 - Touch-Screen LCD and Button Layout

OPERATION

Continued

FUNCTIONAL DESCRIPTION

NOTE: All function adjustments will be automatically accepted 15-seconds after pressing a given touch zone or button. The user may press the MODE/SET button to immediately accept the adjustment manually.

MODES OF OPERATION

OPERATION MODES:

- MANUAL OFF
- MANUAL ON
- THERMOSTAT (with optional PROGRAM Mode)

The modes may be cycled in the order above by touching the MODE Zone or pressing the MODE/SET Button.

MANUAL OFF MODE:

- Transmits flame OFF command.
- Pilot Method: Intermittent Pilot Ignition (IPI)/ Spark-to-Pilot only (continuous/standing pilot not allowed)
 - Pilot flame will be turned OFF
- **LCD Displays:**
 - MODE Zone: OFF is displayed
 - ROOM TEMP Zone: Measured temperature is displayed
 - SET TEMP Zone: Blank
 - TIME/PROG Zone: Current day indicator and current time is displayed
 - FLAME Zone: Blank

MANUAL ON MODE:

- Transmits flame ON command.
- Pilot Method: Intermittent Pilot Ignition (IPI)/ Spark-to-Pilot only (continuous/standing pilot not allowed)
- Pilot flame will be ignited before turn Main Flame ON.
- **LCD Displays:**
 - MODE Zone: ON is displayed
 - ROOM TEMP Zone: Measured temperature is displayed
 - SET TEMP Zone: Blank
 - TIME/PROG Zone: Current day indicator and current time is displayed
 - FLAME Zone: A Flame Icon and flame setting level number is displayed

THERMOSTAT MODE:

- Will cycle flame on and off based on room and set temperatures. Will transmit ON command if SET TEMP (+SWING) is higher than ROOM TEMP and will transmit OFF command if SET TEMP (-SWING) is lower than ROOM TEMP.
- Built-in thermostat will measure room temperature.
- All programming should be written for deg. F and converted to deg. C when selected.
- Temperatures may be displayed in degrees F (factory default) or degrees C. Press the UP and DOWN Buttons simultaneously to change between degrees F and C.
- SET TEMP: While in THERMOSTAT mode, press the UP or DOWN Button to change the SET TEMP (45-90 deg. F, 7-32 deg. C); the new set temperature will automatically be accepted after 2 seconds. The factory default SET TEMP is 68 deg. F.
- SWING Temperature: This model does not allow for SWING temperature adjustment. This model utilizes thermostatic flame modulation that will modulation the main flame based on the difference between room temperature and set temperature (see example below).
- Important - factory SWING TEMPERATURE setting is 2 degrees. The thermostatic flame modulation feature will not allow this SWING to be changed.

EXAMPLE:

Set Temperature	Room Temp.	Flame Level
	74F	OFF
	73F	Level 1
Set Temperature (72) →	72F	Level 2
	71F (or less)	Level 3

- Pilot Method: Continuous/Standing Pilot only (Intermittent Pilot Ignition (IPI)/Spark-to-Pilot not allowed).
- Pilot flame will remain ON when Main Flame Cycles ON and OFF.
- Manual Flame Adjustment while in THERMOSTAT mode: If Flame-A is manually adjusted while in thermostat mode, it will override the automatic flame setting until the flame cycles off, then back ON thermostatically; when the flame cycles ON again, automatic flame adjustment will resume. Automatic flame adjustment will also resume if the operational mode is cycled out of, then back into THERMOSTAT mode or if the SET temperature is changed.

OPERATION

Continued

- THERMOSTAT OFF LCD Displays:
 - MODE Zone: THERMO and OFF is displayed
 - ROOM TEMP Zone: Measured temperature is displayed
 - SET TEMP Zone: SET TEMP is displayed
 - TIME/PROG Zone: Current day indicator and current time is displayed
 - FLAME Zone: Blank
- THERMOSTAT ON LCD Displays:
 - MODE Zone: THERMO and ON are displayed
 - ROOM TEMP Zone: Measured temperature is displayed
 - SET TEMP Zone: SET TEMP is displayed
 - TIME/PROG Zone: Current day indicator and current time is displayed
 - FLAME Zone: A Flame Icon and flame setting level number is displayed
- The time of day will be in 12-hour AM, 12-hour PM format. Midnight will be displayed as 12:00am.
- Day/Time Setup:
 1. Touch and hold the MODE Zone for 5 seconds to enter Day/Time Setup.
 2. Press the UP or DOWN Buttons to adjust the day of week (press the MODE/SET Button or wait for 15 seconds for adjustment to be accepted, then enter hour of day adjustment).
 1. Press the UP or DOWN Buttons to adjust the hour of the day. The time will advance in 1-hour increments; AM and PM will change when the hour advances to 12:00 midnight and 12:00 noon respectively (press the MODE/SET Button or wait for 15 seconds for adjustment to be accepted, then enter minute of hour adjustment).
 2. Press the UP or DOWN Buttons to adjust the minute of the hour. The time will advance in 1-minute increments (press the MODE/SET Button or wait for 15 seconds and the transmitter will exit Day/Time Setup and return to normal operation).
 3. LCD Displays – when in Day/Time Setup:
 - MODE Zone: Blank
 - ROOM TEMP Zone: Blank
 - SET TEMP Zone: Blank
 - TIME/PROG Zone: Day of Week, or Time of Day will Flash
 - FLAME Zone: Blank

Thermostat Disable Feature

- The Thermostat Mode (described above) may be disabled for applications where a thermostat is not allowed or undesirable. When Thermostat Mode is Disabled:
 - The Modes of operation will cycle between MANUAL ON and MANUAL OFF (omitting THERMO).
 - Program Operation (described below) is also disabled.
 - The SET TEMP zone will be blank.
 - The room temperature will still be measured and displayed in the ROOM TEMP Zone.
 - The TIME/PROG zone will continue to display the Clock and Day of week, but none of the icons associated with Program Mode will be displayed.
- To disable or re-enable the Thermostat, the transmitter must be in MANUAL OFF Mode, then touch and hold the SET TEMP Zone and the DOWN Button simultaneously for 10- seconds. The LCD screen will go blank except either THERMO and OFF or THERMO and ON will flash 3-times (0.5-seconds OFF, 0.5-seconds ON) to indicate the change has been made.

DAY AND TIME DISPLAY

- The current day of week and time of day will be continuously displayed in the TIME/PROG Zone (except during Setup operations).
- The day of week will be displayed as one of the following: S, M, T, W, T, F, S

Program Operation

- Touch the TIME/PROG Zone to activate or deactivate Program Operation. Touching the MODE Zone or pressing the MODE/SET Button will also deactivate Program Operation. When Program Operation is deactivated, the transmitter will return to MANUAL OFF Mode.
- Program Operation will cycle fireplace ignition ON and OFF based on time settings (2 weekend periods and 2 weekday periods) and thermostat settings. Press the MODE/SET Button or wait for 15 seconds to advance to each subsequent program setting.
- To enter Program Setup, touch and hold the TIME/PROG Zone for 5 seconds.

OPERATION

Continued

- Program OFF LCD Displays:
 - MODE Zone: OFF
 - ROOM TEMP Zone: Measured temperature is displayed
 - SET TEMP Zone: Blank
 - TIME/PROG Zone: Current day indicator, current time, and Program status (P1- OFF or P2-OFF) is displayed
 - FLAME Zone: Blank
- Program ON LCD Displays:
 - MODE Zone: THERMO and either ON or OFF is displayed
 - ROOM TEMP Zone: Measured temperature is displayed
 - SET TEMP Zone: SET TEMP is displayed
 - TIME/PROG Zone: Current day indicator, current time, and Program status (P1- ON or P2-ON) is displayed
 - FLAME Zone:
 - If Thermostat is ON, A Flame Icon and flame setting level number is displayed.
 - If Thermostat is OFF, display is blank.

Program Disable Feature

- The Program Mode (described above) may be disabled for applications where a program operation is not allowed or undesirable. When Program Mode is Disabled:
 - The user will not be able to activate Program Mode
 - The user will not be able to enter Program Setup or edit Program Mode settings.
 - The TIME/PROG zone will continue to display the Clock and Day of week, but none of the icons associated with Program Mode will be displayed.
- To disable or re-enable the Program Mode, the transmitter must be in MANUAL OFF Mode, then touch and hold the TIME/PROG Zone and the DOWN Button simultaneously for 10-seconds. The LCD screen will go blank except either PROGRAM and OFF (OFF display in MODE Zone) or PROGRAM and ON (ON display in MODE Zone) will flash 3-times (0.5-seconds OFF, 0.5-seconds ON) to indicate the change has been made.

Flame-A (or Main) Adjustment

- Transmits a flame height setting command to the control module to adjust the Flame-A height.
- Available settings are 1-3 with a factory default of 3. Refer to the THERMOSTAT Mode section for additional details on flame modulation in THERMOSTAT mode.
- While in MANUAL ON, THERMOSTAT ON, or PROGRAM ON modes, touch the FLAME Zone to enter Flame-A Adjustment, then press the UP or DOWN buttons to raise and lower the flame; press the MODE/SET Button or wait for 15 seconds to accept the new setting.
- LCD Display: When setting the Flame-A height, the Flame-A icon, and Flame-A setting number will flash in the FLAME Zone.

Child-Lock Operation

- Child-Lock operation prevents any user input to the transmitter. No mode of operation or feature may be adjusted when Child-Lock is activated. All automatic functions (thermostat, program, etc.) will continue normally.
- To activate or deactivate the Child-Lock feature, press and hold the MODE/SET and DOWN Buttons simultaneously for 5 seconds.
- LCD Displays:
 - When activated, the LOCK icon will appear in the MODE Zone.
 - If any touch-zone or button is pressed when activated, the LCD backlight will illuminate and the LOCK icon will flash for 5 seconds in the MODE Zone.

Room Temperature Limit

- The Room Temperature Limit Shutdown feature will operate in MANUAL ON, THERMOSTAT ON mode, and PROGRAM ON modes. If the room temperature reaches 95 deg. F or greater, the transmitter will automatically change to MANUAL OFF mode and send a MANUAL OFF command to the control module. If the user turns the control back ON and the room temperature is still 95F or greater, the transmitter will switch to back manual OFF and send another OFF command the next time the transmitter reads and updates the room temperature (2-minute update interval).

OPERATION

Continued

LEARN PROCESS (PAIRING THE REMOTE TO THE CONTROL MODULE)

NOTE: The transmitter must be in the "OFF" or "THERMO OFF" in order to allow the remote to pair with the control module.

To pair the remote transmitter to the control module, press the learn switch and release. There should be an audible beep indicating the module is ready to accept a transmitter code. Next, press the mode/set button twice on the transmitter within 60 seconds to send a signal (the "MODE/SET" button must be pressed once to activate the screen [lights up] and then a second time for the remote and module to pair). If the signal is received, the module should beep indicating the signal was received. **NOTE:** Module will remain "Open" and ready to accept a signal for 60 seconds after the learn switch is pressed.

The control module will learn up to 3 different transmitter security codes (only one may be a thermostat style).

Press and hold in the learn switch in for 6 seconds to clear all transmitter security codes retained in memory. After releasing the switch, three series of beeps will be heard. This serves as proof that the transmitter's security codes have been cleared from memory. Repeat learn process as needed.

SWITCHING ON

To turn the system on, press the Burner ON/OFF switch to the ON position (see figure on **Page 26**). Once the start up process is complete, the main burner and pilot will be lit.

REGULATING THE FLAME LEVEL.

1. To decrease the flame level to low, press the Hi-Low switch to the ON position.
2. To increase to high flame level, press the Hi-Low switch to the OFF position.

NOTE: If the appliance is set to the low flame level and turned off, it will light on high flame level and then cycle to low flame level on the next flame sequence.

SWITCHING OFF

To switch off the fire, press the Burner ON/OFF Switch to the OFF position.

WARNING: Do not convert heater to use different fuel type. Only use heater with fuel type specified.

Unit Mounted Switches



Burner

Hi-Lo

Learn

ON/OFF Switch turns the burner on and off

Hi (Off) / Low (On) Switch controls the main burner flame height

Momentary Switch (Learn) is for programming the remote (see instructions above).

INSPECTING BURNERS

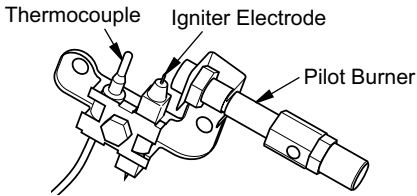

Figure 35 - Pilot (Natural)

Check pilot flame pattern and burner flame patterns often.

PILOT FLAME PATTERN

Figure 36 shows a correct pilot flame pattern. **Figure 37** shows an incorrect pilot flame pattern. The incorrect pilot flame is not touching the thermocouple. This will cause the thermocouple to cool. When the thermocouple cools, the appliance will shut down.

If pilot flame pattern is incorrect, as shown in **Figure 37**.

- turn appliance off (see [To Turn Off Gas to Appliance, Page 20](#))
- see [Troubleshooting, Page 30](#)

NOTE: The pilot flame on natural gas units will have a slight curve, but flame should be blue and have no yellow or orange color.

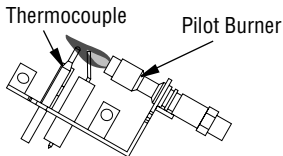

Figure 36 - Correct Pilot Flame Pattern (Your pilot may vary from pilots shown)

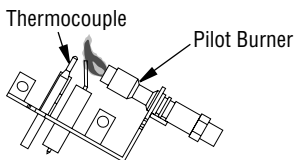

Figure 37 - Incorrect Pilot Flame Pattern (Your pilot may vary from pilots shown)

CLEANING AND MAINTENANCE

WARNING: Turn off fireplace and let cool before cleaning.

CAUTION: You must keep control areas, burner, and circulating air passageways of fireplace clean. Inspect these areas of fireplace before each use. Have fireplace inspected yearly by a qualified service person. Fireplace may need more frequent cleaning due to excessive lint from carpeting, bedding material, pet hair, etc.

WARNING: Failure to keep the primary air opening(s) of the burner(s) clean may result in sooting and property damage.

Perform a periodic visual check of pilot and burner flame.

BURNER INJECTOR HOLDER AND PILOT AIR INLET HOLE

The primary air inlet holes allow the proper amount of air to mix with the gas. This provides a clean burning flame. Keep these holes clear of dust, dirt, lint and pet hair. Clean these air inlet holes prior to each heating season. Blocked air holes will create soot. We recommend that you clean the unit every three months during operation and have appliance inspected yearly by a qualified service person.

We also recommend that you keep the burner tube and pilot assembly clean and free of dust and dirt. To clean these parts we recommend using compressed air no greater than 30 PSI. Your local computer store, hardware store or home center may carry compressed air in a can. If using compressed air in a can, please follow the directions on the can. If you don't follow directions on the can, you could damage the pilot assembly.

1. Shut off unit, including pilot. Allow unit to cool for at least thirty minutes.
2. Inspect burner, pilot and primary air inlet holes on injector holder for dust and dirt (see **Figure 38, Page 28**).
3. Blow air through the ports/slots and holes in the burner.

CLEANING AND MAINTENANCE

Continued

4. Check injector holder located at end of burner tube again. Remove any large particles of dust, dirt, lint or pet hair with a soft cloth or vacuum cleaner nozzle.
5. Blow air into the primary air holes on the injector holder.
6. In case any large clumps of dust have now been pushed into the burner repeat steps 3 and 4.

Clean pilot assembly also. Additional cleaning may be needed for proper pilot operation based on use/lack of use. A yellow tip on the pilot flame may indicate dust and dirt in the pilot assembly. There is a small pilot air inlet hole about from where the pilot flame comes out of pilot assembly (see **Figure 39**). With unit off, lightly blow air through air inlet hole. You may blow through a drinking straw if compressed air is not available.

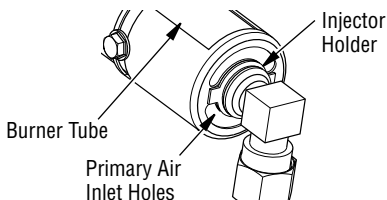

Figure 38 - Injector Holder On Outlet Burner Tube

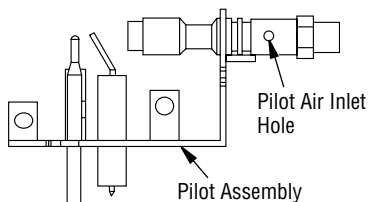

Figure 39 - Pilot Inlet Air Hole (Your pilot may vary from pilot shown)

LOGS

- If you remove logs for cleaning, refer to *Installing Logs, Embers and Volcanic Stone*, **Page 16**, to properly replace logs.
- Replace log(s) if broken or chipped (dime-sized or larger).

MAIN BURNER

Periodically inspect all burner flame holes with appliance running. All slotted burner flame holes should be open with flame present. All round burner flame holes should be open with a small blue flame present. Some burner flame holes may become blocked by debris or rust, with no flame present. If so, turn off appliance and let cool. Remove blockage, blocked burner flame holes will create soot.

WARNING: The injector holders (air shutters) are not adjustable. Do not move injector holders from their original positions.

SPECIFICATIONS

MNF24INE AND MNF30INE

- Rating (Variable): 28,000/38,000 Btu/Hr
- Type Gas: Natural
- Ignition: Electronic
- Manifold Pressure: 4.5" W.C.
- Inlet Gas Pressure (in. of water):
Max - 10.5" W.C., Min* - 5" W.C.

*For purpose of input adjustment

MNF24IPE AND MNF30IPE

- Rating (Variable): 31,000/39,000 Btu/Hr
- Type Gas: Propane/LP
- Ignition: Electronic
- Manifold Pressure: 8.0" W.C.
- Inlet Gas Pressure (in. of water):
Max - 14" W.C., Min* - 11" W.C.

*For purpose of input adjustment

WIRING DIAGRAM

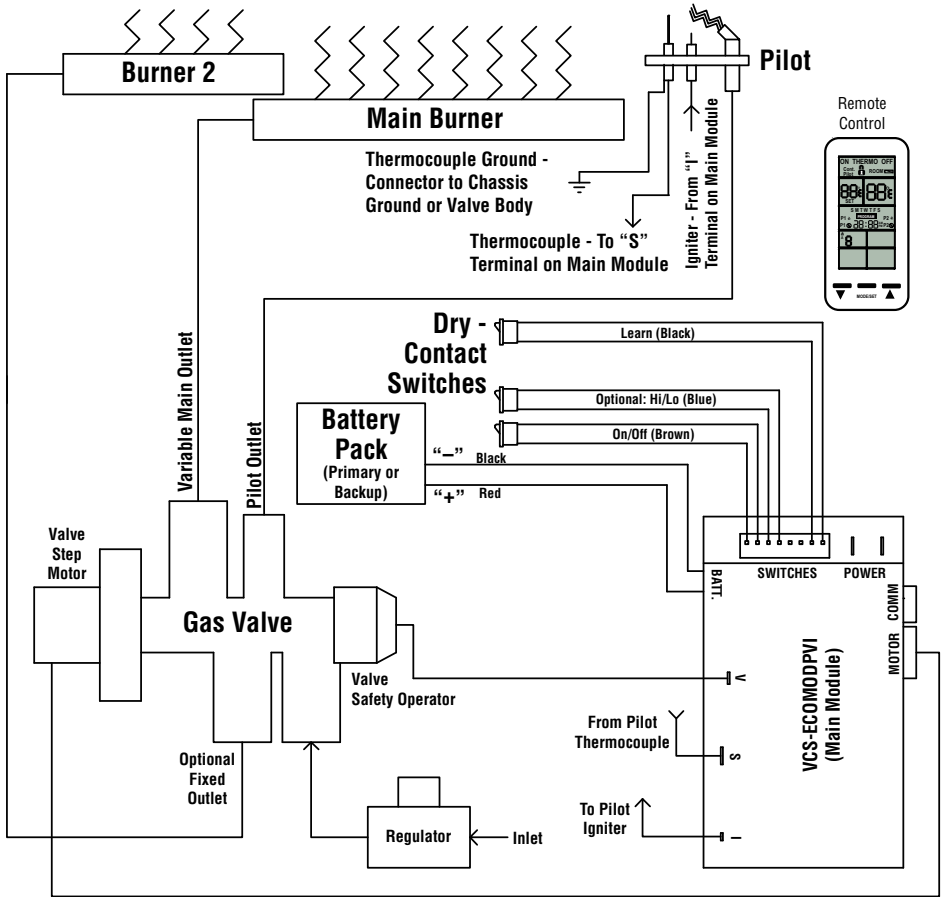

CAUTION: Label all wires prior to disconnection when servicing controls. Wiring errors can cause improper and dangerous operation. Verify proper operation after servicing.

TROUBLESHOOTING

⚠ WARNING: Turn off appliance and let cool before servicing. Only a qualified service person should service and repair heater.

⚠ CAUTION: Never use a wire, needle or similar object to clean ODS/pilot. This can damage ODS/pilot unit.

NOTE: All troubleshooting items are listed in order of operation.

OBSERVED PROBLEM	POSSIBLE CAUSE	REMEDY
<p>Either the remote or touch pad buttons are pressed to start the burner ignition sequence and there is no function or response.</p>	<ol style="list-style-type: none"> 1. Missing or weak batteries at power supply box or remote. Control module may beep 10 times or may not beep at all. LCD display may show "BATTERY ERROR". 2. Unplugged power supply (battery) box 3. Touch pad not plugged in to module or plugged in incorrectly 4. Control valve wiring harness not plugged in or not in proper position 5. Remote not communicating with control module 	<ol style="list-style-type: none"> 1. Check batteries and replace if needed. (Batteries in the power supply box can be tested with a multimeter at the two connections at the back of the battery housing where the red and black wires are connected. Set the multimeter to DC voltage, initiate the ignition sequence, and observe the voltage while the system is lighting (under load). The system will not function under 3.8 volts and batteries should be replaced if the voltage is under 4.0 volts.) 2. Plug power supply box to module see Page 16. 3. Plug touch pad in module see Page 16, Figure 19. Check to see it is positioned as shown. 4. Check to see that the control valve wiring harness' blue connector is plugged in to the module. Check to see that it is aligned with the mating pins. If any pins are visible, then the connector is not in the correct position. If this is the case, disconnect, align, and reconnect to the module. 5. The remote communicates with the module periodically. It doesn't communicate with the module continuously to conserve battery power.

TROUBLESHOOTING

Continued

OBSERVED PROBLEM	POSSIBLE CAUSE	REMEDY
<p>Either the remote or touch pad buttons are pressed to start the burner ignition sequence and there is no function or response. (Continued from Page 30).</p>	6. LED is blinking	6. This indicates the battery power is low. Replace the batteries in the power supply box.
	7. Igniter cable is not connected	7. Check the igniter connection at both the control module and the ODS pilot. Connect if loose.
	8. Igniter cable pinched or wet	8. Free igniter cable if pinched by any metal or tubing. Keep igniter cable dry.
	9. Broken Igniter cable.	9. Replace wire harness including igniter cable.
	10. Igniter electrode positioned wrong.	10. Replace ODS pilot assembly.
	11. Igniter electrode broken.	11. Replace ODS pilot assembly.
	12. Control module sounds 2 cycles of 3 beeps; LCD display may show ROM ERROR	12. Replace control module
	13. Control module sounds 2 cycles of 5 beeps; LCD display may show SUPPORT ERROR	13. Ground cable from control valve wiring harness is not grounding properly. Reposition spade terminal so that it makes contact with burner chassis metal or valve body.
	14. Bad reception from remote	14. Change batteries in remote. Check reception of signal from a shorter distance. If still not working, try changing the channel in the configuration menu. If this does not fix the problem, reset the channel (<i>see Page 22 Channel Selection</i>) and follow the instructions in Pairing on Page 26 . Replace remote and control module as a final action.
	15. If LED on touch pad is continuously on, the cable is connected the wrong way.	15. Disconnect the touch pad between the long and short cables, turn the short cable with the touch pad over and reconnect.
	16. The control module sounds 2 cycles of 5 beeps. The wiring assembly from the control valve is disconnected or broken.	16. Connect the wiring harness at the control module. Replace the valve assembly if all other cause/remedies fail to correct his problem.

TROUBLESHOOTING

Continued

OBSERVED PROBLEM	POSSIBLE CAUSE	REMEDY
<p>When igniter button is pressed on the remote or touch pad, the pilot sparks but there is no ignition.</p>	<ol style="list-style-type: none"> 1. Gas supply turned off or equipment shutoff valve closed 2. Air in gas lines. 3. Thermocouple circuit between the control valve and the control module is open. 4. No gas to the ODS pilot 5. Depleted gas supply (propane/LP only) 6. Valve cable is disconnected or broken. 7. ODS pilot is clogged 8. Gas regulator setting is not correct 	<ol style="list-style-type: none"> 1. Turn on gas supply or open equipment shutoff valve. 2. Continue turning the burner system ON and OFF. Repeat igniting operation until air is removed. On first time ignitions, air in the lines is common and it is not uncommon to repeat the ignition sequence 10 to 15 times before enough gas is at the ODS pilot for it to light. 3. Check the thermocouple connection at the control valve and also at the control module. The thermocouple connection at the control valve should be hand tight plus 1/4 to 1/2 turn. You should not be able to loosen the thermocouple at the control valve with your hand. Check the thermocouple terminal connection at the control module. If it is loose, remove it with needle nose pliers, using the pliers, slightly close the terminal's opening and reinstall on to the control module. 4. While the pilot is sparking, check for gas flow at the ODS pilot. If flow is present, try to light the pilot with a long reach lighter. If it will not light but the flame is disturbed, air is in the line. Cycle through the ignition sequence to clear the line of air until gas is present. If no flow is present at the gas valve, check to see all shut off valves are open. Verify proper pressure is supplied to the valve. Excessive pressure can lock out the appliance's regulator. Also check to see that the wiring harness from the control valve is properly connected at the control module. The wiring harness connection housing can be identified by it's blue connector housing. 5. Contact local propane/LP gas company. 6. Connect valve cable correctly 7. Clean ODS pilot (<i>see Cleaning and Maintenance, Page 27</i>) or replace ODS pilot assembly. 8. Replace gas regulator

TROUBLESHOOTING

Continued

OBSERVED PROBLEM	POSSIBLE CAUSE	REMEDY
ODS pilot lights but pilot flame goes out before burners light.	<ol style="list-style-type: none"> 1. Equipment shutoff valve not fully open 2. Missing or weak batteries at power supply box or remote. 3. Thermocouple circuit between the ODS pilot and control module is loose or damaged. 4. Pilot flame not touching thermocouple, which allows thermocouple to cool, causing pilot flame to go out. This problem could be caused by one or both of the following: A) Low gas pressure or B) Dirty or partially clogged ODS pilot. 5. Thermocouple damaged 6. Control valve damaged. 	<ol style="list-style-type: none"> 1. Fully open equipment shutoff valve. 2. Check batteries and replace if needed. (Batteries in the power supply box can be tested with a multimeter at the two connections at the back of the battery housing where the red and black wires are connected. Set the multimeter to DC voltage, initiate the ignition sequence, and observe the voltage while the system is lighting (under load). The system will not function under 3.8 volts and batteries should be replaced if the voltage is under 4.0 volts.) 3. Check thermocouple terminal connection at the control module. If it is loose, remove it with needle nose pliers, using the pliers, slightly close the terminal's opening and reinstall on to the control module. 4. A) Contact local natural or propane/LP gas company. B) Clean ODS pilot (<i>see Cleaning and Maintenance, Page 27</i>) or replace ODS pilot assembly. 5. Replace ODS pilot assembly. 6. Replace control valve
Burner system lights from remote but not from touch pad	<ol style="list-style-type: none"> 1. Touch pad cable disconnected or broken 2. Defective touch pad 	<ol style="list-style-type: none"> 1. Connect or replace touch pad and cable. 2. Replace touch pad
Burner system does not ignite the burner while the remote is in the program mode.	<ol style="list-style-type: none"> 1. Program mode does not work if soft start is deactivated. 	<ol style="list-style-type: none"> 1. Activate soft start in the remote.
Burner system shuts off after operating 6 seconds then sounds 5 beeps	<ol style="list-style-type: none"> 1. Short in touch pad wiring. 	<ol style="list-style-type: none"> 1. Replace touch pad and wiring harness.
Low battery power in remote.	<ol style="list-style-type: none"> 1. Batteries are weak. LOW BATTERY is shown in remote display. 	<ol style="list-style-type: none"> 1. Replace batteries in remote.

TROUBLESHOOTING

Continued

OBSERVED PROBLEM	POSSIBLE CAUSE	REMEDY
Burner system shuts off. Control module sounds 2 cycles of 3 beeps.	1. Faulty control module	1. Replace control module.
Burner system shuts off. Control module sounds 2 cycles of 3 beeps.	1. Remote and control module not communicating properly 2. Faulty control module	1. Follow Pairing instructions on Page 26 to re-pair remote to control module. 2. Replace control module
Burner system shuts off. Control module sounds 20 beeps.	1. Loss of communication between control module and remote after 18 minutes.	1. Either the remote is too far from the burner system or the remote needs new batteries. The remote should work within 20 feet of the burner system. If it does not, replace the batteries in the remote and battery supply box.
Burner system shuts off. Control module sounds 1 long beep.	1. Control module is too hot	1. Check to see the fireplace size meets the minimum requirements. Call technical service.
Burner systems shuts off.	1. The SAFETY temperature setting in the remote has shut the burner system off.	1. The remote includes a shut off that is preset at 40C (104F). If the remote is placed in a location that is at or above this temperature it will shut the burner system off. Placing the remote on a mantel may result in this problem. If it occurs, relocate the remote to a cooler location.
Burner system lights or shuts off without touching the remote.	1. More than one burner system is present and operating on the same frequency.	1. Follow Pairing instructions on Page 26 to re-pair remote to control module.

TROUBLESHOOTING

Continued

OBSERVED PROBLEM	POSSIBLE CAUSE	REMEDY
Burners do not light after ODS/pilot is lit	<ol style="list-style-type: none"> 1. Inlet gas pressure is too low 2. Burner orifice(s) clogged 3. Mislocated crossover tube 	<ol style="list-style-type: none"> 1. Contact local natural or propane/LP gas company 2. Clean burner(s) (<i>see Cleaning and Maintenance, Page 27</i>) or replace burner orifice(s) 3. Contact qualified service person
Delayed ignition of one or both burners	<ol style="list-style-type: none"> 1. Manifold pressure is too low 2. Burner orifice(s) clogged 3. Mislocated crossover tube 	<ol style="list-style-type: none"> 1. Contact local natural or propane/LP gas company 2. Clean burner(s) (<i>see Cleaning and Maintenance, Page 27</i>) or replace burner orifice(s) 3. Contact qualified service person
Burner backfiring during combustion	<ol style="list-style-type: none"> 1. Burner orifice is clogged or damaged 2. Damaged burner 3. Gas regulator defective 	<ol style="list-style-type: none"> 1. Clean burner (<i>see Cleaning and Maintenance, Page 27</i>) or replace burner orifice 2. Replace damaged burner 3. Replace gas regulator
Yellow flame in middle burner during burner combustion	<ol style="list-style-type: none"> 1. Not enough air 2. Gas regulator defective 	<ol style="list-style-type: none"> 1. Check burner(s) for dirt and debris. If found, clean burner(s) (<i>see Cleaning and Maintenance, Page 27</i>) 2. Replace gas regulator
Slight smoke or odor during initial operation	<ol style="list-style-type: none"> 1. Residues from manufacturing processes and logs curing 	<ol style="list-style-type: none"> 1. Problem will stop after a few hours of operation
Appliance produces a whistling noise when burners are lit	<ol style="list-style-type: none"> 1. Set the unit to HI by using the remote when burners are cold 2. Air in gas line 3. Air passageways on appliance blocked 4. Dirty or partially clogged burner orifice(s) 	<ol style="list-style-type: none"> 1. Set the unit to LO by using the remote and let warm up for a minute 2. Operate burners until air is removed from line. Have gas line checked by local natural or propane/LP gas company 3. Observe minimum installation clearances (<i>see Pages 9-11</i>) 4. Clean burners (<i>see Cleaning and Maintenance, Page 27</i>) or replace burner orifice(s)
White powder residue forming within burner box or on adjacent walls or furniture	<ol style="list-style-type: none"> 1. When heated, vapors from furniture polish, wax, carpet cleaners, etc. may turn into white powder residue 	<ol style="list-style-type: none"> 1. Turn appliance off when using furniture polish, wax, carpet cleaners or similar products
Moisture/condensation noticed on windows	<ol style="list-style-type: none"> 1. Not enough combustion/ventilation air 	<ol style="list-style-type: none"> 1. Refer to <i>Air for Combustion and Ventilation</i> requirements (<i>Page 6</i>)
Appliance produces a clicking/ticking noise just after burners are lit or shut off	<ol style="list-style-type: none"> 1. Metal expanding while heating or contracting while cooling 	<ol style="list-style-type: none"> 1. This is normal with most appliances. If noise is excessive, contact qualified service person

TROUBLESHOOTING

Continued



WARNING: If you smell gas

- Shut off gas supply.
- Do not try to light any appliance.
- Do not touch any electrical switch; do not use any phone in your building.
- Immediately call your gas supplier from a neighbor's phone. Follow the gas supplier's instructions.
- If you cannot reach your gas supplier, call the fire department.

IMPORTANT: Operating heater where impurities in air exist may create odors. Cleaning supplies, paint, paint remover, cigarette smoke, cements and glues, new carpet or textiles, etc., create fumes. These fumes may mix with combustion air and create odors. These odors will disappear over time.

OBSERVED PROBLEM	POSSIBLE CAUSE	REMEDY
Appliance produces unwanted odors	<ol style="list-style-type: none"> 1. Appliance burning vapors from paint, hair spray, glues, cleaners, chemicals, new carpet, etc. (See <i>IMPORTANT</i> statement above) 2. Low fuel supply (propane/LP only) 3. Gas leak. See Warning statement at top of Page 	<ol style="list-style-type: none"> 1. Open window to ventilate room. Stop using odor causing products while appliance is running 2. Refill supply tank (propane/LP only) 3. Locate and correct all leaks (see <i>Checking Gas Connections, Page 14</i>)
Appliance shuts off in use (ODS operates)	<ol style="list-style-type: none"> 1. Not enough fresh air is available 2. Low line pressure 3. ODS/pilot is partially clogged 	<ol style="list-style-type: none"> 1. Open window and/or door for ventilation 2. Contact local natural or propane/LP gas company 3. Clean ODS/pilot (see <i>Cleaning and Maintenance, Page 27</i>)
Gas odor even when control knob is in OFF position	<ol style="list-style-type: none"> 1. Gas leak. See Warning statement at top of Page 2. Control valve or gas control defective 	<ol style="list-style-type: none"> 1. Locate and correct all leaks (see <i>Checking Gas Connections, Page 14</i>) 2. Replace control valve or gas control
Gas odor during combustion	<ol style="list-style-type: none"> 1. Foreign matter between control valve and burner 2. Gas leak. See Warning statement at top of Page 	<ol style="list-style-type: none"> 1. Take apart gas tubing and remove foreign matter 2. Locate and correct all leaks (see <i>Checking Gas Connections, Page 14</i>)
Log set cycles to pilot, but room temperature drops to a lower than ideal level before log set comes back on	<ol style="list-style-type: none"> 1. Optional Hand-held remote control is too close to appliance 	<ol style="list-style-type: none"> 1. Move hand-held remote control unit farther away from the appliance

ACCESSORIES

Purchase these appliance accessories from your local dealer. If they can not supply these accessories, contact IHP at SuperiorFireplaces.us.com for referral information. You can also write to the address listed on the back Page of this manual.

Only kits supplied by IHP shall be used in the installation of this appliance. Use of non-approved accessory/part kit(s) can result in poor performance and safety hazards.

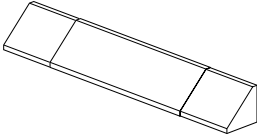

FIREPLACE HOOD, BLACK

Cat. No. F1764, Model GA6050

For all models. Helps deflect heat away from mantel or wall above fireplace. Fits openings 28" to 48" wide.



VOLCANIC STONE

Cat. No. 80L42, Model FDVS

For all models. Order when additional volcanic stone is desired.

EMBER KITS

Cat. No J6207 - Platinum Embers

Cat. No J6208 - Glowing Embers (rockwool)



FLOOR MEDIA KIT

Cat. No. F1762, Model FM100

For all models. Includes Volcanic Stone, burner embers, and burner cinders.



MAGNIFLAME ACCESSORY LOG KIT

Cat. No. F0252, Model LAMF



GAS APPLIANCE INSTALLATION KIT

Cat. No. F0249, Model CIKA

PARTS

REMOTE CONTROL MODELS

MNF24INE, MNF24IPE, MNF30INE, AND MNF30IPE

Cat. No.	Model
F2087	MNF24INE
F2090	MNF24IPE
F2093	MNF30INE
F2096	MNF30IPE

⚠ WARNING: Failure to position the parts in accordance with these diagrams or failure to use only parts specifically approved with this heater may result in property damage or personal injury.

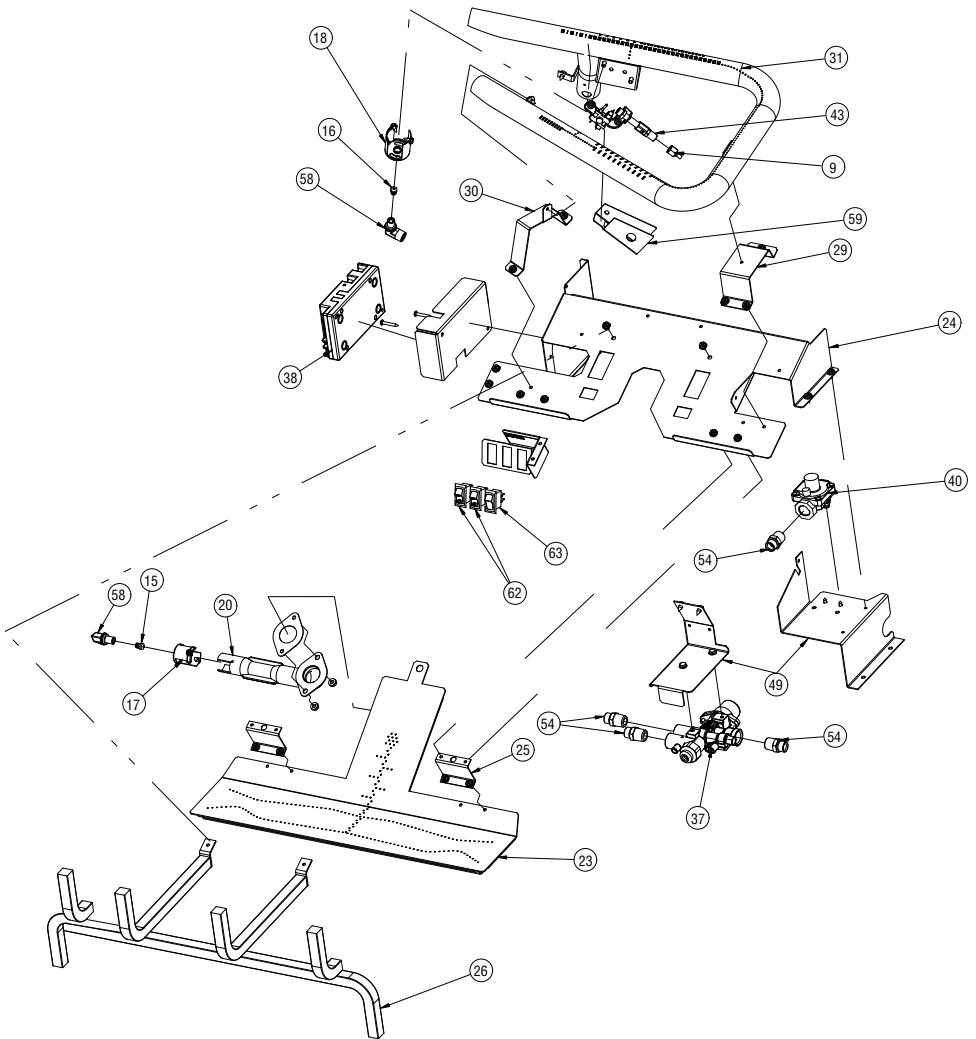

PARTS

REMOTE CONTROL MODELS

MFN24INE, MFN24IPE, MFN30INE, AND MFN30IPE

This list contains replaceable parts used in your appliance. When ordering parts, follow the instructions listed under Replacement Parts on *Page 42* of this manual.

⚠ WARNING: Contact an IHP dealer to obtain any of these parts. Never use substitute materials not approved by IHP. Use of non-approved parts can result in poor performance and safety hazards.

KEY NO.	PART NO.	DESCRIPTION					QTY.
			MFN24INE	MFN24IPE	MFN30INE	MFN30IPE	
15	J8079	Orifice, 0.028 (Pan)					1
15	RP099056-46	Orifice, 0.051 (Pan)	•	•	•	•	1
16	J3615	Orifice, 0.07 (Rear)		•	•	•	1
16	F2930	Orifice, 0.1065 (Rear)	•	•	•	•	1
58	J6127	Orifice Holder,90 Degree Elbow	•	•	•	•	2
9	F2932	Tube, Pilot	•	•	•	•	1
17	J4886	Shutter, Air	•	•	•	•	1
18	J5199	Shutter, Air	•	•	•	•	1
18	J5200	Shutter, Air	•	•	•	•	1
20	J5416	Tube, Venturi	•	•	•	•	1
24	J8094	Base, 24" & 30"	•	•	•	•	1
25	J6147	Bracket, Front Burner	•	•	•	•	2
29	J8175	Bracket, Right Burner	•	•	•	•	1
30	J8176	Bracket, Left Burner	•	•	•	•	1
31	J6356	Burner, MF Series Yellow Flame	•	•	•	•	1
23	J6364	Assy, Pan Burner MF42/48	•	•	•	•	1
33	J6489	Plate, Log Placement	•	•	•	•	1
26	J8177	Assy, Grate MF42	•	•	•	•	1
26	J6491	Assy, Grate MF48	•	•	•	•	1
37	F2947	Valve, Electronic Copreci	•	•	•	•	1
37	F2948	Valve, Electronic Copreci	•	•	•	•	1
38	F2960	Module, Ecoflow ODS RF Control	•	•	•	•	1
39	F2958	Supply, Battery Power	•	•	•	•	1
40	J7603	Regulator, Gas	•	•	•	•	1
40	J3653	Regulator, Gas	•	•	•	•	1
43	F2955	Pilot, NG Electric Copreci	•	•	•	•	1
43	F2956	Pilot, LP Electric Copreci	•	•	•	•	1
62	27K30	Switch, Rocker, Burner On/Off	•	•	•	•	1
62	F3456	Switch, Rocker, Burner Hi/Lo	•	•	•	•	1
63	F2964	Switch, Momentary	•	•	•	•	1
48	J8076	Leg, Support	•	•	•	•	1
49	F2951	Bracket, Valve & Regulator	•	•	•	•	1
54	J3562	Connector, Male 3/8 NPTF to 3/8 Tube	•	•	•	•	4
64	F2942	Bracket, Caution Decal With Switch Holes	•	•	•	•	1
60	F3195	Shield, Control Module Heat	•	•	•	•	1
59	J6508	Shield, Pilot	•	•	•	•	1
64	F3194	Bracket, Module	•	•	•	•	1
68	F3196	Shield, Valve Heat	•	•	•	•	1
PARTS AVAILABLE — NOT SHOWN							
	J3664	Decal, Caution Label	•	•	•	•	1
	J3689	Kit, Hardware	•	•	•	•	1
	80L42	Volcanic Stone, FDVS	•	•	•	•	1
	J6207	Kit, Platinum Embers	•	•	•	•	2
	J6208	Kit, Glowing Embers (rockwool)	•	•	•	•	2
	J6585	Plate Lighting Instructions	•	•	•	•	1
	F2950	Remote Control ODS Touchscreen	•	•	•	•	1
	F2949	ODS Remote Wiring Harness	•	•	•	•	1
	J7933	V-Wire	•	•	•	•	1
	J6599	Flex Line Regulator to Valve	•	•	•	•	1
	J8083	Flex Line Valve to Pan Burner	•	•	•	•	1
	J8084	Flex Line Valve to Rear Burner	•	•	•	•	1
	F2957	ODS Spark Wire	•	•	•	•	1

PARTS

LOG SET MODELS

LMF24GTA/B, LMF30GTA/B, AND LMF36GTA/B (GIANT TIMBERS)

This list contains replaceable parts used in your appliance. When ordering parts, follow the instructions listed under [Replacement Parts](#) on **Page 42** of this manual.

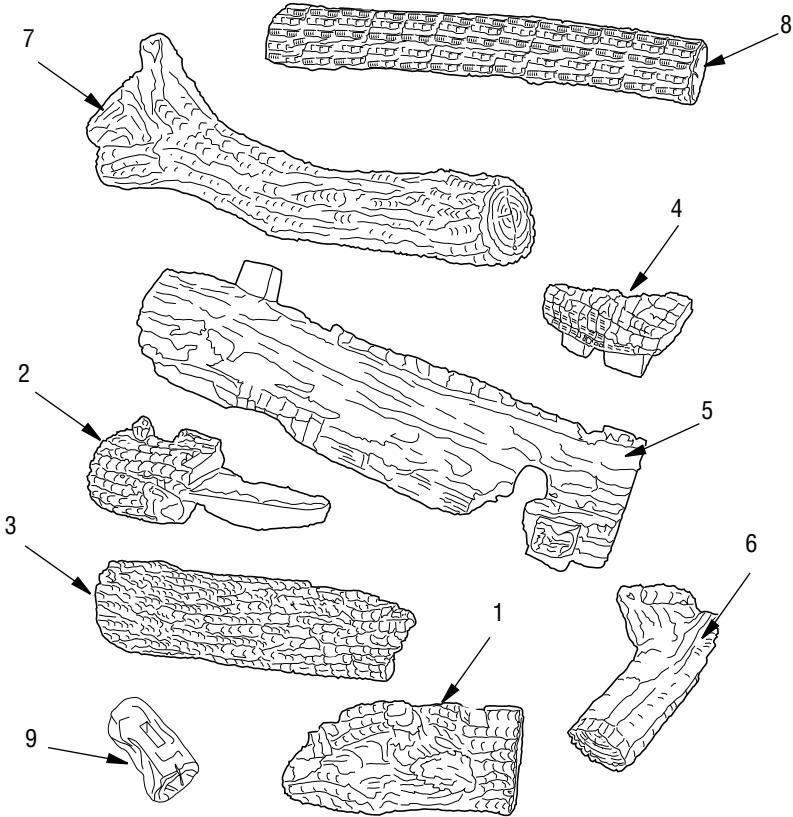

KEY NO.	LMF24GTA/B		LMF30GTA/B		LMF36GTA/B		DESCRIPTION	QTY.
	CAT. NO.	Log Id. #	CAT. NO.	Log Id. #	CAT. NO.	Log Id. #		
1	J6696	D-061	J6516	D-019	J6527	D-027	Log, Front Right	1
2	J6697	D-060	J6517	D-018	J6528	D-026	Log, Back Left	1
3	J6698	D-059	J6518	D-017	J6529	D-025	Log, Front Left	1
4	J6519	D-020	J6519	D-020	J6519	D-020	Log, Charred	1
5	J6699	D-063	J6520	D-021	J6530	D-028	Log, Middle Split	1
6	J6521	D-022	J6521	D-022	J6521	D-022	Log, Right Split Crossover	1
7	J6522	D-024	J6522	D-024	J6522	D-024	Log, Front Top	1
8	J6700	D-062	J6523	D-023	J6531	D-029	Log, Back Top	1
9	J6496	None	J6496	None	J6496	None	Log Switch	1

Each log includes a reference number. The first number indicates the order it is placed on the burner assembly. The next two numbers indicate the set size.

PARTS

LOG SET MODELS

LMF24MOA/B, LMF30MOA/B, AND LMF36MOA/B

This list contains replaceable parts used in your appliance. When ordering parts, follow the instructions listed under Replacement Parts on **Page 42** of this manual.

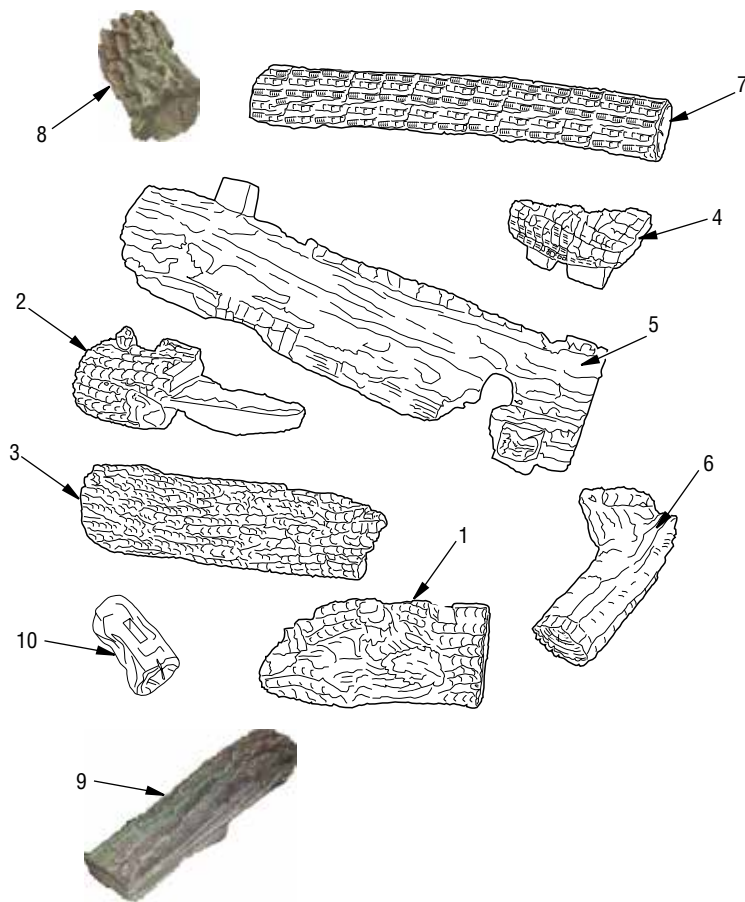

KEY NO.	LMF24MOA/B		LMF30MOA/B		LMF36MOA/B		DESCRIPTION	QTY.
	CAT. NO.	Log Id. #	CAT. NO.	Log Id. #	CAT. NO.	Log Id. #		
1	J8245	D-061	J8253	D-019	J8259	D-027	Log, Front Right	1
2	J8246	D-060	J8254	D-018	J8260	D-026	Log, Back Left	1
3	J8247	D-059	J8255	D-017	J8261	D-025	Log, Front Left	1
4	J6519	D-020	J6519	D-020	J6519	D-020	Log, Charred	1
5	J8248	D-063	J8256	D-021	J8262	D-028	Log, Middle Split	1
6	J8249	D-022	J8249	D-022	J8249	D-022	Log, Right Split Crossover	1
7	F4584	D-062	J8258	D-023	J8264	D-029	Log, Back Top	1
8	J8251	D-080	J8251	D-080	J8251	D-080	Log, Top Left	1
9	J8252	D-081	J8252	D-081	J8252	D-081	Log, Top Right	1
10	J6496	None	J6496	None	J6496	None	Log Switch	1

Each log includes a reference number. The first number indicates the order it is placed on the burner assembly. The next two numbers indicate the set size.

REPLACEMENT PARTS

See **Pages 38-41** for a complete replacement parts list. Use only parts supplied from the manufacturer.

Normally, all parts should be ordered through your IHP distributor or dealer. Parts will be shipped at prevailing prices at time of order.

NEVER USE SUBSTITUTE MATERIALS. USE OF NON-APPROVED PARTS CAN RESULT IN POOR PERFORMANCE AND SAFETY HAZARDS.

SERVICE HINTS

When Gas Pressure Is Too Low

- pilot will not stay lit
- burners will have delayed ignition
- appliance will not produce specified heat
- propane/LP gas supply may be low

You may feel your gas pressure is too low. If so, contact your local propane/LP or natural gas supplier.

When ordering repair parts, always give the following information:

1. The model number of the appliance.
2. The serial number of the appliance.
3. The part number.
4. The description of the part.
5. The quantity required.
6. The installation date of the appliance.

If you encounter any problems or have any questions concerning the installation or application of this appliance, please contact your dealer.

TECHNICAL SERVICE

You may have further questions about installation, operation, or troubleshooting. Please contact your IHP dealer for any questions or concerns. When contacting your dealer please have your model and serial numbers of your appliance ready. You can also visit our web site at SuperiorFireplaces.us.com.

Innovative Hearth Products Superior® Brand Gas Log Set Limited Three Year Warranty

THE WARRANTY

Innovative Hearth Products Limited Three Year Warranty ("IHP") warrants your Superior® brand Gas Log Set ("Product") to be free from defects in materials and workmanship at the time of manufacture. The logs and grate carry the Limited Three Year Warranty. After installation, if covered components manufactured by IHP are found to be defective in materials or workmanship during the Limited Three Year Warranty period and while the Product remains at the site of the original installation, IHP will, at its option, repair or replace the covered components. If repair or replacement is not commercially practical, IHP will, at its option, refund the purchase price or wholesale price of the IHP product, whichever is applicable. IHP will also pay IHP prevailing labor rates, as determined in its sole discretion, incurred in repairing or replacing such components. THERE ARE EXCLUSIONS AND LIMITATIONS to this Limited Three Year Warranty as described herein.

COVERAGE COMMENCEMENT DATE

Warranty coverage begins on the date of purchase. In the case of new home construction, warranty coverage begins on the date of first occupancy of the dwelling or six months after the sale of the Product by an independent IHP dealer, whichever occurs earlier. The warranty shall commence no later than 24 months following the date of product shipment from IHP, regardless of the installation or occupancy date.

EXCLUSIONS AND LIMITATIONS

This Limited Three Year Warranty applies only if the Product is installed in the United States or Canada and only if operated and maintained in accordance with the printed instructions accompanying the Product and in compliance with all applicable installation and building codes and good trade practices.

This warranty is non-transferable and extends to the original owner only. The Product must be purchased through a listed supplier of IHP and proof of purchase must be provided. The following do not carry the Limited Three Year Warranty but are warranted as follows:

Gas components – Repair or replacement for one year from the date of installation.

Remote control – Repair or replacement for one year from the date of installation.

Labor coverage – Prevailing IHP labor rates apply for the warranty period of the component.

Parts not otherwise listed carry a 90 day warranty from the date of installation.

Whenever practicable, IHP will provide replacement parts, if available, for a period of 10 years from the last date of manufacture of the product.

IHP will not be responsible for: (a) damages caused by normal wear and tear, accident, riot, fire, flood or acts of God; (b) damages caused by abuse, negligence, misuse, or unauthorized alteration or repair of the Product affecting its stability or performance (The Product must be subjected to normal use. The Product is designed to burn either natural or propane gas only. Burning conventional fuels such as wood, coal or any other solid fuel will cause damage to the Product, will produce excessive temperatures and could result in a fire hazard.); (c) damages caused by failing to provide proper maintenance and service in accordance with the instructions provided with the Product; (d) damages, repairs or inefficiency resulting from faulty installation or application of the Product.

This Limited Three Year Warranty covers only parts and labor as provided herein. In no case shall IHP be responsible for materials, components or construction which are not manufactured or supplied by IHP or for the labor necessary to install, repair or remove such materials, components or construction. Additional utility bills incurred due to any malfunction or defect in equipment are not covered by this warranty. All replacement or repair components will be shipped F.O.B. from the nearest stocking IHP factory.

LIMITATION ON LIABILITY

It is expressly agreed and understood that IHP's sole obligation and the purchaser's exclusive remedy under this warranty, under any other warranty, expressed or implied, or in contract, tort or otherwise, shall be limited to replacement, repair, or refund, as specified herein.

In no event shall IHP be liable for any incidental or consequential damages caused by defects in the Product, whether such damage occurs or is discovered before or after replacement or repair, and whether such damage is caused by IHP's negligence. IHP has not made and does not make any representation or warranty of fitness for a particular use or purpose, and there is no implied condition of fitness for a particular use or purpose.

IHP makes no expressed warranties except as stated in this Limited Three Year Warranty. The duration of any implied warranty is limited to the duration of this expressed warranty.

No one is authorized to change this Limited Three Year Warranty or to create for IHP any other obligation or liability in connection with the Product. Some states and provinces do not allow the exclusion or limitation of incidental or consequential damages, so the above limitations or exclusions may not apply to you. The provisions of this Limited Three Year Warranty are in addition to and not a modification of or subtraction from any statutory warranties and other rights and remedies provided by law.

INVESTIGATION OF CLAIMS AGAINST WARRANTY

IHP reserves the right to investigate any and all claims against this Limited Three Year Warranty and to decide, in its sole discretion, upon the method of settlement.

To receive the benefits and advantages described in this Limited Three Year Warranty, the appliance must be installed and repaired by a licensed contractor approved by IHP.

Contact IHP at the address provided herein to obtain a listing of approved dealers/distributors. **IHP shall in no event be responsible for any warranty work done by a contractor that is not approved without first obtaining IHP's prior written consent.**

HOW TO REGISTER A CLAIM AGAINST WARRANTY

In order for any claim under this warranty to be valid, you must contact the IHP dealer/distributor from which you purchased the product. If you cannot locate the dealer/distributor, then you must notify IHP in writing. IHP must be notified of the claimed defect in writing within 90 days of the date of failure. Notices should be directed to the IHP Warranty Department at 1769 East Lawrence Street; Russellville, AL 35654 or visit our website at WWW.SUPERIORFIREPLACES.US.COM.

SuperiorFireplaces.us.com

Record the following important information about your appliance:

Appliance model number	
Appliance serial number	
Date appliance was Installed	
Type of gas appliance uses	
Dealer name	

Innovative Hearth Products (IHP) reserves the right to make changes at any time, without notice, in design, materials, specifications, prices and also to discontinue colors, styles and products. Consult your local distributor for fireplace code information.

