

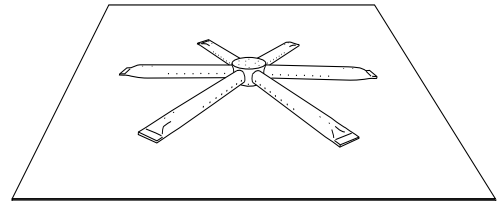

DO NOT DISCARD. THIS MANUAL HAS IMPORTANT OPERATING AND MAINTENANCE INSTRUCTIONS. LEAVE WITH THE HOMEOWNER.

MODEL:

SERIAL #:

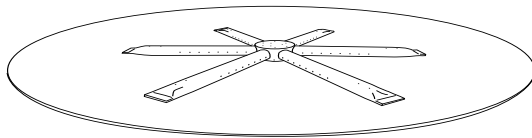

MODELS

Natural Gas	Description	Propane
FPB-25SFBSTMSI-N	25" Square Flat Disc (TMSI)	FPB-25DBSTMSI-P
FPB-25SFBSTFS-N	25" Square Flat Disc (TFS)	FPB-25SFBSTFS-P
FPB-26DBSTMSI-N	26" Round Flat Disc (TMSI)	FPB-26DBSTMSI-P
FPB-29DBSTMSI-N	29" Round Flat Disc (TMSI)	FPB-29DBSTMSI-P
FPB-29DBSTFS-N	29" Round Flat Disc (TFS)	FPB-29DBSTFS-P
FPB-30SFBSTMSI-N	30" Square Flat Disc (TMSI)	FPB-30SFBSTMSI-P
FPB-30SFBSTFS-N	30" Square Flat Disc (TFS)	FPB-30SFBSTFS-P
FPB-34DBSTMSI-N	34" Round Flat Disc (TMSI)	FPB-34DBSTMSI-P
FPB-34DBSTFS-N	34" Round Flat Disc (TFS)	FPB-34DBSTFS-P
FPB-34SFBSTMSI-N	34" Square Flat Disc (TMSI)	FPB-34SFBSTMSI-P
FPB-34SFBSTFS-N	34" Square Flat Disc (TFS)	FPB-34SFBSTFS-P

Outdoor Round and Square Flat Fire Pit Discs

Installation and Operating Instructions

IF YOU CANNOT READ OR UNDERSTAND THESE INSTALLATION INSTRUCTIONS DO NOT ATTEMPT TO INSTALL OR OPERATE THIS APPLIANCE

INSTALLATION PRECAUTION:

This fire pit requires a minimum 18-square inches (per side) of cross ventilation. Failure to provide proper ventilation can void the warranty.



Warning: For Outdoor Use Only



We recommend that our gas hearth products be installed and serviced by professionals who are certified in the U.S. by the National Fireplace Institute® (NFI) as NFI Gas Specialists.



DANGER

CARBON MONOXIDE HAZARD

This appliance can produce carbon monoxide which has no odor.

Using it in an enclosed area can kill you.

Never use this appliance in an enclosed space such as a camper, tent, car or home.



**DANGER
FIRE OR EXPLOSION
HAZARD**

If you smell gas:

1. Shut off gas to the appliance
2. Extinguish any open flame.
3. If odor continues, leave the area immediately.
4. After leaving the area, call your gas supplier or fire department.



WARNING

Do not store or use gasoline or other flammable vapors and liquids in the vicinity of this or other appliance.

An LP cylinder not connected for use shall not be stored in the vicinity of this or any other appliance.

WARNING

Do not leave unattended during use.
Do not use for cooking.
Follow all gas leak procedures in this manual prior to operation.



WARNING

Improper installation, adjustment, alteration, service or maintenance can cause injury or property damage, personal injury or loss of life
Read the owner's information manual provided with this appliance.
Installation and service must be performed by a qualified installer, service agency, or the gas supplier.

WARNING

If the information in this manual is not followed exactly, a fire or explosion may result causing property damage, personal injury, or **loss of life**.

FOR YOUR SAFETY

Do not store or use gasoline or other flammable vapors and liquids in the vicinity of this or other appliances.



Fuels used in gas fired appliances, and the products of combustion such as fuels, contain chemicals known to cause cancer, birth defects and/or other reproductive harm.
This warning is issued pursuant to the California Health & Safety Code Sec. 25249.1

CALIFORNIA PROPOSITION 65



WARNING

This product is designed to operate with one of the following fuel sources: Liquid Propane or Natural Gas. The fuel used to operate this product, and the products of combustion of such fuel, can expose you to chemicals including Benzene which is known to the State of California to cause cancer, birth defects and other reproductive harm and Carbon Monoxide which is known to the State of California to cause birth defects or other reproductive harm.

(For more information go to: www.p65Warnings.ca.gov.)

NOTE: This installation instruction covers two different ignition systems: Thermocouple Manual Safety (TMSI) and Thermocouple Flame Sense (TFS). Look for your specific section in the table of contents.

TABLE OF CONTENTS

Specifications	4-5
Disc Specifications	4
Btu Specifications	5
Gas Pipe Sizing Chart	6
Preparation for Non-Combustible Structure	7
Hard Piping to Fire Pit	7
Cross Ventilation Requirements	7
High Elevation	7
Installation into an Approved Enclosure	8
Section A Thermocouple Manual Safety (TMSI) Installation	9-14
Operation & Lighting	12
TMSI Troubleshooting/Maintenance	13
Expanded TMSI Model View	14
Section B Thermocouple Flame Sense (TFS) Installation	15-23
Operation & Lighting	19
TFS Troubleshooting/Maintenance	20-22
Expanded TFS Model View	23
Replacement Parts	24
Replacement Parts List	25-26
Optional Accessories	27



All media (i.e. lava rock, lava stones, lava boulders and fire glass) has the potential of thermal spalling. This is a process that may occur when media is wet and moisture gets trapped inside of the material due to rapid temperature differences. When this happens the media has the potential to crack or “pop” outside the fireplace.

WE HIGHLY RECOMMEND COVERING ALL FIRE FEATURES WHEN NOT IN USE

The use of a cover can lessen the impact of thermal spalling; however, heavy rains, high humidity and the presence of moisture may still cause the media to pop.

ALWAYS USE CAUTION WHEN USING THE FIRE FEATURE

Extra caution should be taken when lighting a fireplace when heavy rains, high humidity and moisture are present. Light the fireplace; leave the area allowing any moisture in the media to dissipate. We strongly recommend that during this drying out time that you monitor the fire feature from a distance. This drying out period should be no less than 30 minutes. Continue monitoring the flame from distance to ensure that all popping has ceased before fully enjoying the fire.

SPECIFICATIONS

Model: Natural Gas (NG)	Model: Propane Gas (LP)	A Disc Depth	B Pan Diameter	C Min.Install Opening	D Ground Level	E Side Wall	F Combustible Ceiling	G Combustible Floor
FPB-25SFBSTMSI-N	FPB-25SFBSTMSI-P	1/16"	25"	24"	8"	19"	69"	18"
FPB-25SFBSTFS-N	FPB-25SFBSTFS-N	1/16"	25"	24"	18"	19"	69"	18"
FPB-26DBSTMSI-N	FPB-26DBSTMSI-P	1/16"	26"	25"	8"	19"	69"	18"
FPB-26DBSTFS-N	FPB-26DBSTFS-P	1/16"	26"	25"	18"	19"	69"	18"
FPB-29DBSTMSI-N	FPB-29DBSTMSI-P	1/16"	29"	28"	8"	19"	69"	18"
FPB-29DBSTFS-N	FPB-29DBSTFS-P	1/16"	29"	28"	18"	19"	69"	18"
FPB-30SFBSTMSI-N	FPB-30SFBSTMSI-N	1/16"	30"	31"	8"	19"	69"	18"
FPB-30SFBSTFSI-N	FPB-30SFBSTFS-N	1/16"	30"	31"	18"	19"	69"	18"
FPB-34DBSTMSI-N	FPB-34DBSTMSI-P	1/16"	34"	33"	8"	19"	69"	18"
FPB-34DBSTFS-N	FPB-34DBSTFS-P	1/16"	34"	33"	18"	19"	69"	18"

Table1. Disc Specifications

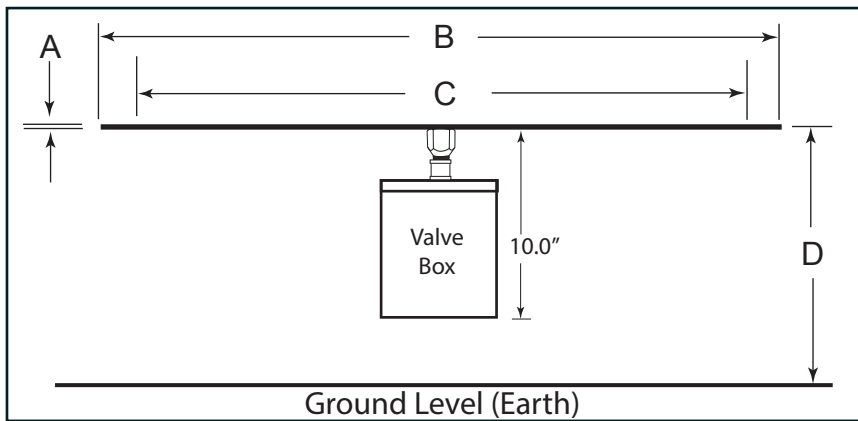

Fig.1. Flat Disc Dimensions; refer to Table 1. **NOTE:** A TFS model is depicted above. Disc dimensions for all TMSI models are the same without the valve box shown.

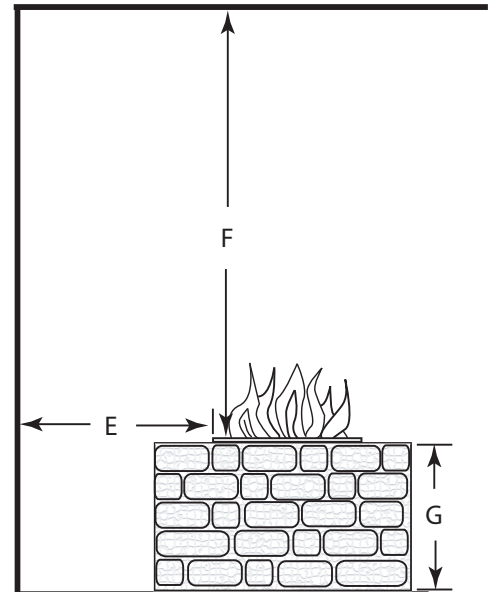

Fig. 2. Clearance to Combustibles
(Not to be used in an enclosed space)

SPECIFICATIONS

<i>Model: Round Disc NG</i>	<i>NG Factory Orifice</i>	<i>NG Btu's High</i>	<i>NG Btu's Low</i>	<i>Model: Round Disc LP</i>	<i>LP Factory Orifice</i>	<i>Btu's High</i>	<i>LP Btu's Low</i>
FPB-25SFBSTMSI-N	#29	65,000 (19.05kW)	N/A	FPB-25SFBSTMSI-P	#41	65,000 (19.05kW)	N/A
FPB-25SFBSTFSI-N	#7	105,000 (30.77kW)	51,000 (14.94kW)	FPB-25SFBSTFSI-P	#31	100,000 (29.30kW)	49,500 (14.50kW)
FPB-26DBSTMSI-N	#29	65,000 (19.05kW)	N/A	FPB-26DBSTMSI-P	#41	65,000 (19.05kW)	N/A
FPB-29DBSTMSI-N	#29	65,000 (19.05kW)	N/A	FPB-29DBSTMSI-P	#41	65,000 (19.05kW)	N/A
FPB-29DBSTFS-N	#7	105,000 (30.77kW)	51,000 (14.94kW)	FPB-29DBSTFS-P	#31	100,000 (29.30kW)	49,500 (14.50kW)
FPB-30SFBSTMSI-N	#29	65,000 (19.05kW)	N/A	FPB-30SFBSTMSI-P	#41	65,000 (19.05kW)	N/A
FPB-30SFBSTFS-N	#7	105,000 (30.77kW)	51,000 (14.94kW)	FPB-30SFBSTFS-P	#31	100,000 (29.30kW)	49,500 (14.50kW)
FPB-34DBSTMSI-N	#29	65,000 (19.05kW)	N/A	FPB-34DBSTMSI-P	#41	65,000 (19.05kW)	N/A
FPB-34DBSTFS-N	#7	105,000 (30.77kW)	51,000 (14.94kW)	FPB-34DBSTFS-P	#31	100,000 (29.30kW)	49,500 (14.50kW)

Table 2. Btu Specifications

<i>Pressure</i>	NG	LP
Min. Inlet	5.0" WC (1.24 kPa)	10.5" WC (2.61kPa)
Max. Inlet	10.5" WC (2.61kPa)	13.0" WC (3.23kPa)
Normal Inlet	7.0" WC (1.74kPa)	11.0" WC (2.73kPa)
Manifold	5.0" WC (1.24 kPa)	10.5" WC (2.61kPa)

Disclaimer: Btu listings are based on 7.0"WC for Natural Gas and 11.0"WC for Liquid Propane (LP) at the burner orifice. Flex line size and proper gas pipe sizing will also affect Btu's. As a result your Btu's may vary slightly from Table 2 specifications.

Table 3. Gas Pressures

NOTE: All disc (TMSI & TFS) models come from the factory as Natural gas and can be converted to Propane (LP) gas in the field except TFS models, they must be order specifically as Natural gas or Propane; they cannot be field converted from one gas to another.

NOTICE

Firegear Outdoors fire pits are constructed and tested to follow the rigid ANSI standards for gas appliances and manufactured safely providing dependable and certified products. If these fire pits are not installed according to the installation manual (i.e. not providing ventilation, not providing proper drainage, installing fire pits below grade or modifying the existing products from a normal installation). Firegear Outdoors cannot be responsible if the product does not operate as designed.

Modifying the fire pit directly out of the carton will void the warranty and nullify any listing it was certified for. Before you consider creating your own custom design with a certified product ensure you contact Firegear Outdoors to consult the installation before proceeding. If you move forward and modify a product without consulting, Firegear Outdoors cannot be responsible if the product does not operate as designed.



GAS PIPE SIZING CHART

GAS PIPE SIZING

NATURAL GAS : PIPE SIZING CHART

Length of Pipe in Feet	1/2"	3/4"	1"	1 - 1/4"	1 - 1/2"	2"	2 - 2 1/2"	3"	4"
10	108	230	387	793	1237	2259	3640	6434	-
20	75	160	280	569	877	1610	2613	5236	9521
30	61	129	224	471	719	1335	2165	4107	7859
40	52	110	196	401	635	1143	1867	3258	6795
50	46	98	177	364	560	1041	1680	2936	6142
60	42	89	159	336	513	957	1559	2684	5647
70	38	82	149	317	476	896	1447	2492	5250
80	36	76	140	239	443	840	1353	2315	4900
90	33	71	133	275	420	793	1288	2203	4667
100	32	68	126	266	411	775	1246	2128	4518
125	28	60	117	243	369	700	1143	1904	4065
150	25	54	105	215	327	625	1008	1689	3645
175	23	50	93	196	303	583	993	1554	3370
200	22	47	84	182	280	541	877	1437	3160
300	17	37	70	145	224	439	686	1139	2539

- Natural Gas (NG) flow is given in thousands of BTU/hr. = 1 cubic foot of NG gas - 1000 BTU
- Nominal pressure at the burner for Natural Gas is 3.5" of water column. (Typical machine supply 5"-7")
- Pipe length must include additional length for all fittings. Add approximately 5 feet of pipe per fitting.
- Natural Gas Example: A machine with a burner that requires 440,000 BTU would need a 1 -1/4" pipe for a 20" long run.

LIQUID PROPANE : PIPE SIZING CHART

Length of Pipe in Feet	1/2"	3/4"	1"	1 - 1/4"	1 - 1/2"	2"	2 - 2 1/2"	3"	4"
10	275	567	1071	2205	3307	6221	10140	17990	35710
20	189	393	732	1496	2299	4331	7046	12510	25520
30	152	315	590	1212	1858	3465	5695	10110	20620
40	129	267	504	1039	1559	2992	4778	8481	17300
50	114	237	448	913	1417	2646	4343	7708	15730
60	103	217	409	834	1275	2394	3908	6936	14150
70	89	185	346	724	1086	2047	3329	5908	12050
80	78	162	307	630	976	1811	2991	5309	10830
90	69	146	275	567	866	1606	2654	4711	9613
100	63	132	252	511	787	1496	2412	4281	8736
125	54	112	209	439	665	1282	2083	3618	7382
150	48	100	185	390	590	1138	1808	3210	6549
175	43	90	168	353	534	1030	1637	2905	5927
200	40	83	155	325	491	947	1505	2671	5450
300	37	77	144	303	458	887	1404	2492	5084

- Liquid Propane (LP) Gas flow is given in thousands of BTU/hr. = 1 cubic foot of LP gas - 2500 BTU.
- This chart refers to low pressure LP, after regulation, Standard nominal pressure at the burner for Liquid Propane Gas is 11" of water column.
- Pipe length must include additional length for all fittings. Add approximately 5 feet of pipe per fitting.
- LP Example: A machine with a burner that requires 440,000 BTU would need a 1" pipe for a 20" long run.

NOTE: The sizing charts above list the specific pipe sizes required for the amount of BTU's for a new gas line installations. If you are using an existing gas line you must take into consideration the existing gas line capacities to ensure you will have proper pressure. **This chart is for reference only, we recommend you consult with a Licensed Plumber/Gas Fitter or NFPA54 (National Fuel Gas Code - current edition) for more details.**

Table 4 Gas pipe sizing chart



WARNING: Proper clearances from combustible materials must be maintained from all sides, top and bottom of this appliance. Use the specifications listed on pages 4 and 5 for proper clearance to combustibles.

PREPARING A NON-COMBUSTIBLE STRUCTURE

The fire pit can be installed on a flat, stable surface, away from any combustible materials. Install fire pit on any level, outdoor non-combustible, flat stable surface or a combustible floor according to the clearances specified in this manual.

NOTE: Do not place fire pit directly on grass, dirt, or rocks as this may prevent proper ventilation (Fig. 3). **Ensure proper water drainage is also incorporated into the fire pit enclosure.**

HARD PIPING TO FIRE PIT WITHOUT GAS PROXIMITY

NOTE: Refer to the NFPA54 (National Fuel Gas Code) for proper pipe sizing. In the absence of NFPA54 booklet, you can use gas pipe sizing chart on page 6.

1. Turn **OFF** gas supply system. **NOTE:** All gas connections (except for brass to brass) require the following: Clean pipe threads using either a wire brush or steel wool. Apply pipe sealant to the fittings before making any connection. **BE CAREFUL!** Ensure all gas connections are snug, but do not over tighten!
2. The primary gas shut-off (not supplied) will require a ½" male flared fitting to enable connection of the stainless steel flex gas line supplied with the fire pit.

IMPORTANT

Installation of Natural or LP gas should be done by a qualified installer, service agency or gas supplier. This appliance must be isolated from the gas supply piping system by closing its manual shutoff valve during any pressure testing of the gas supply piping system at test pressures equal to or less than ½" psig (3.5kPa)

VENTILATION FOR NON-COMBUSTIBLE ENCLOSURE

Fire pits are subjected to many outdoor elements such as rain, snow, wind, heat or cold. **A minimum of 18 square inches of cross ventilation (2 sides) is required to keep the components in good working order.** Use Fig. 3 as a guide to assist to incorporate proper ventilation.

HIGH ELEVATION INSTALLATION

This appliance is listed for elevations from 0- 4500 feet in Canada and the U.S. If elevation exceeds 4500 feet it may be necessary to decrease the input rating by changing the existing burner orifice to a smaller size. Input should be reduced 4% for each 1000 feet beyond the 4500 feet above sea level. Check with your local gas utility for assistance in determining the proper orifice in your location. In some cases the heating value may already be reduced and downsizing the orifice may not be necessary. Refer to NFPA54 Table E.1.1(d) for high altitude orifice sizing.

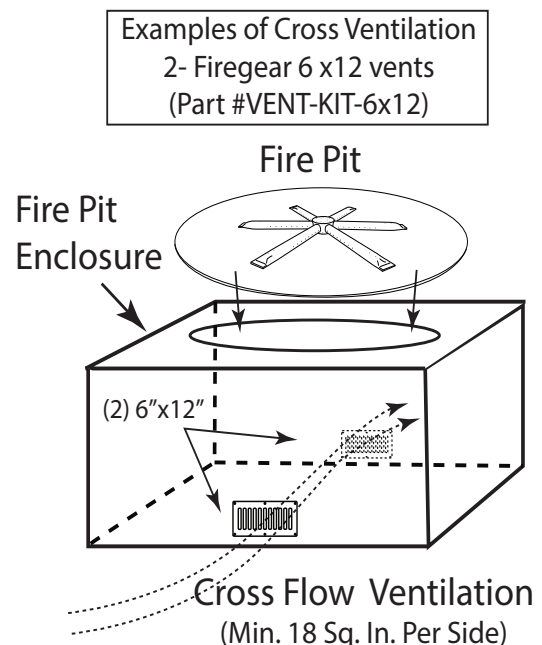

Fig. 3. Cross Ventilation Example

INSTALLATION OF FIRE PIT INTO AN APPROVED ENCLOSURE

REQUIREMENTS

1. Only non-combustible materials should come in direct contact with any part of the fire pit. Underneath area should be non-combustible or a flat level combustible surface according to the clearances specified in this manual..
2. Refer to the NFPA54 (National Fuel Gas Code) for proper pipe sizing. See gas pipe sizing chart on page 6.
3. Determine the size of the round fire pit you are preparing to install (Refer to page 4).
4. You must provide an opening to place the flat disc in a non-combustible enclosure. Do not exceed the maximum opening from Table 1, dimension B located on page 4.
5. Follow the local code requirements for the gas type being used. This fire pit should be installed in accordance with local codes and ordinances or in the absence of local codes, with the latest National Fuel Gas Code, ANSI Z223.1 NFPA54 or CSA B149.1, Natural and Propane Installation Code in Canada.
6. Fire pits create high temperatures, it is very important to have any combustibles at a safe distance. Refer to page 4.
7. **CAUTION: A minimum of 18 square inches of cross ventilation (per side) is required to keep the inside of the enclosure dry. We recommend installation of a VENT-KIT-6x12. See accessory section on page 27.**
8. These products are designed for outdoor use only. Not approved for any indoor use.
9. This fire pit is designed to have lava rock completely covering the spur burner, so that the burner is not visible. Do not cover more than 1" above the top of the burner. When purchasing lava rock use 1" to 2" diameter as a base to cover a flat disc.
10. Gas lines and fittings must be installed into the non-combustible structure. All gas connections must be leak tested before installation of the fire pit. Soapy water leak detection is required before regular use of the fire pit.
11. Do not use materials that will absorb moisture over time and will not release moisture quickly. Moisture can boil in this material and can rapidly break apart and cause damage or personal injury.
12. Never leave any other combustible material on top of the fire pit. This could cause unsafe operation of this system and damage to the component that will not be covered under our warranty.
13. **Ensure proper water drainage is also incorporated into the fire pit enclosure.**

Section A

Thermocouple Manual Safety (TMSI) Installation

Flat disc's are typically used with landscape blocks. The illustrations below show examples of possible installations. Figs. 4 and 5 show the use of the flex frame system which provides the ability to easily remove the disc if necessary.

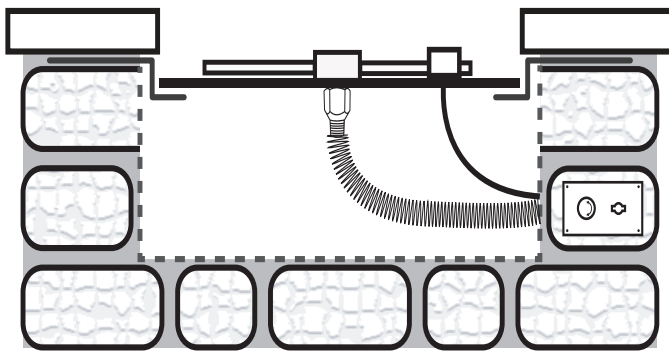

Fig. 4 Shows disc secured under stone caps.

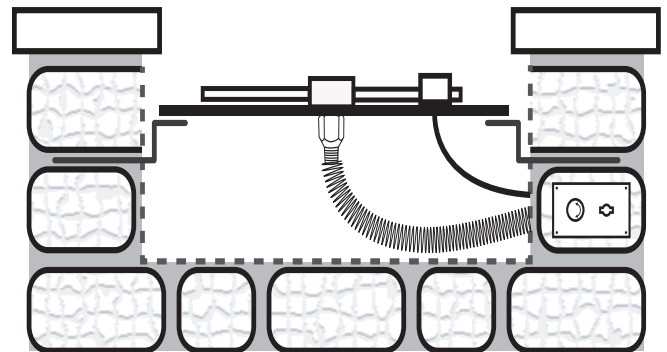

Fig. 5 Shows disc secured between layer of block.

INSTALLING BURNER ORIFICE (OAS)

Locate the burner nipple underneath the burner pan. Ensure the nipple on the spur burner has gas rated Teflon tape wrapped around the threads. Thread the OAS (orifice air shutter) to the nipple of the burning spur clockwise manner. Secure into position. See Fig. 6.

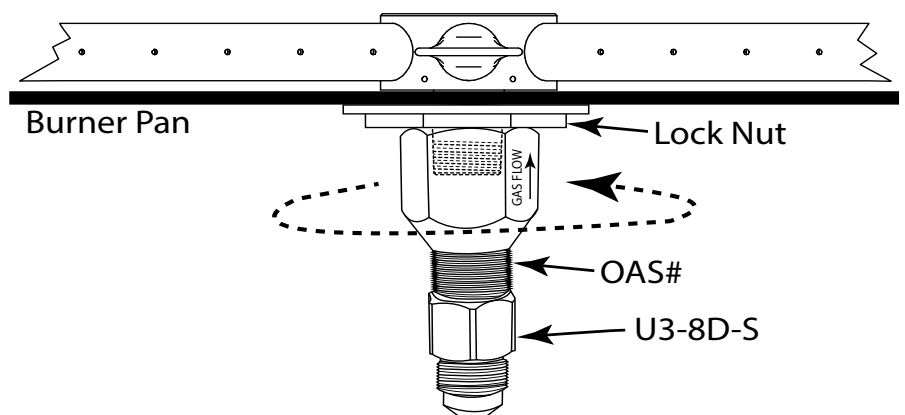

Fig. 6 Installing OAS assembly to spur burner.

INSTALLING GAS VALVE

The gas valve is secured into the mounting plate with a nut. Fig. 7 shows an example of a typical installation.

Illustration shows side view of valve and Piezo ignitor.

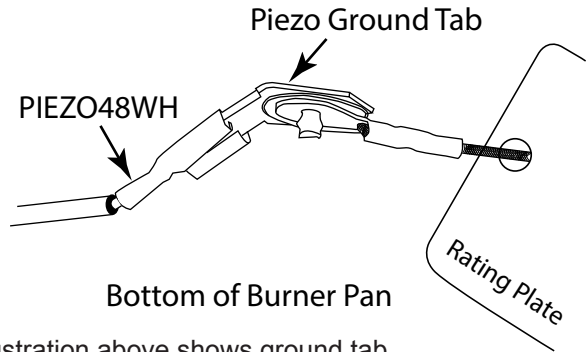
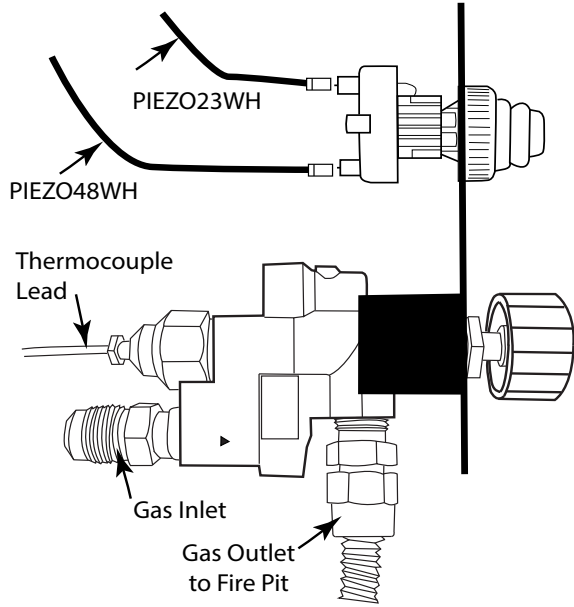

Illustration above shows ground tab connection underneath the burner pan.

Remove red button cap and install battery into Piezo ignitor module.

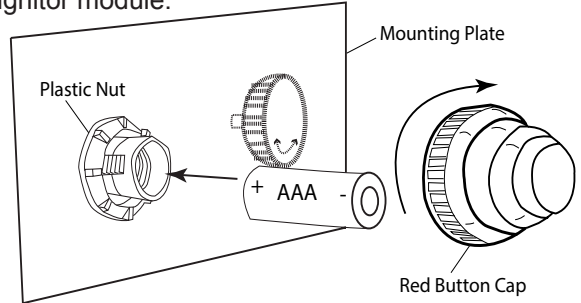

Fig. 7 TMSI typical installation.

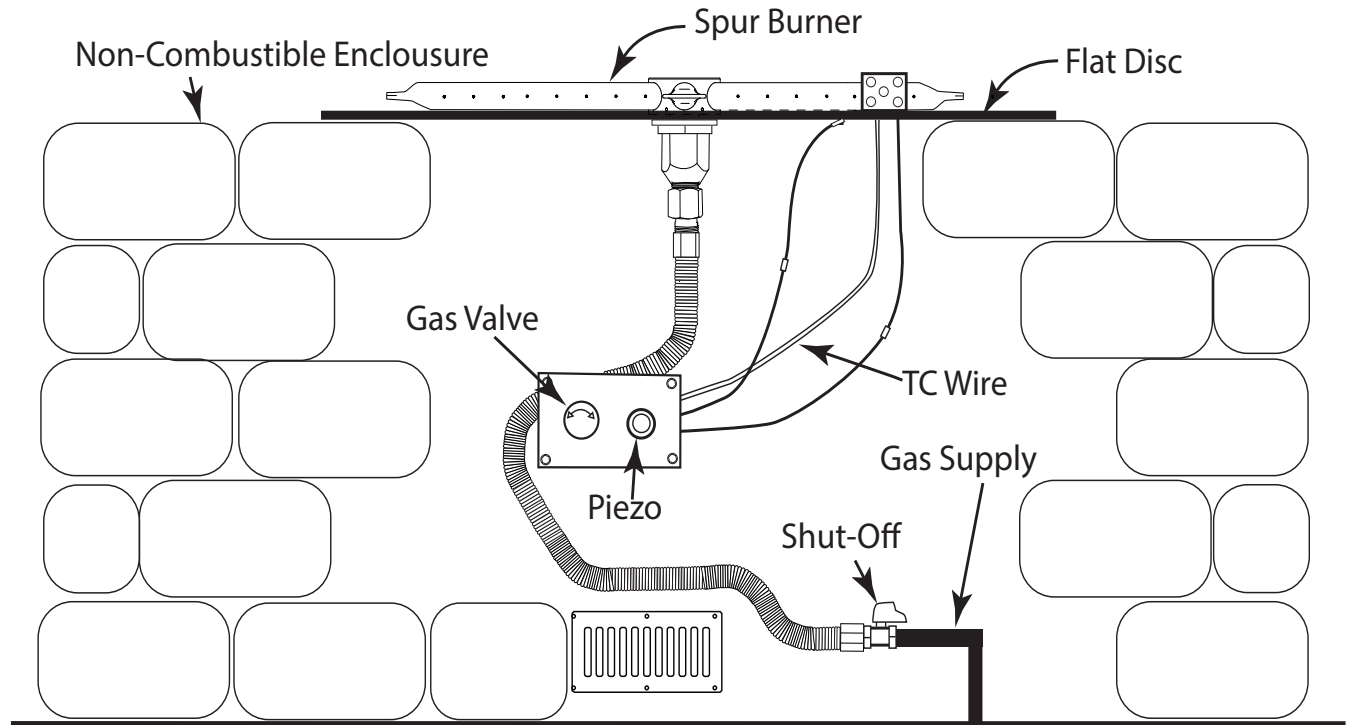

Fig. 8 Typical installation.

Gas valve and flexible gas lines are supplied; gas shut-off is not, but available in accessories page 27. Flex lines with flared fittings do not require Teflon tape or pipe compound. Ensure not to “kink” the flex lines to allow better gas flow of gas. The illustration above is only a guide for the gas connection. Local codes may require different methods to connect the gas supply. **Note: See optional mounting method of TMSI face plate on back of this manual.**

IGNITOR ALIGNMENT

It is important to check that the ignitor probes are properly aligned over top of the burner port holes and did not move during shipping. Use the Fig. 9 as a guide. Before lighting, remove the screen cover of the ignition hood to burner and ensure the thermocouple is directly over top of a burner port hole. The sparking probes and the thermocouple must be in the path of a flame to ignite the gas for proper ignition of the flame. Replace the screen cover and follow the operating instructions.

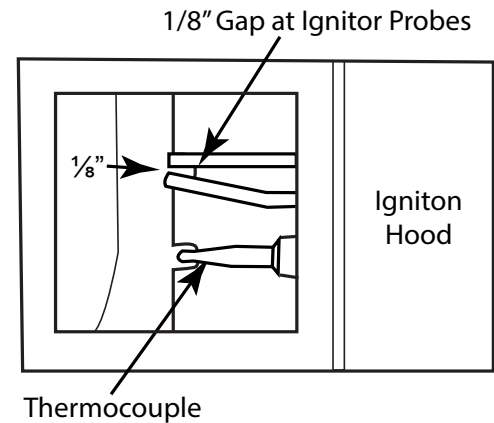

Fig. 9 Proper alignment of thermocouple.

INSTALLATION OF LAVA ROCK/MEDIA INTO BURNER PAN

Install lava rock into the burner pan. Ensure the lava rock is a 1-inch diameter for proper operation. **Note:** Do not pour Lava Rock directly from bag. It should be placed naturally and NOT packed in tight. Loose fitting is important to ensure robust flames. Be sure rocks are free of any excessive dust. This prevents the burner pan weep holes from being plugged and holding water.

IMPORTANT: Do not place rock over top or under the screen cover. The screen must be free of any debris to ensure proper lighting of burner and good flame sense (See Fig. 10).

Cover the burner completely with media but do not make the depth greater than 1-inch over top of the burner portholes.

Do NOT cover the screen mesh with any rock or glass. It must be free of any debris to operate properly.

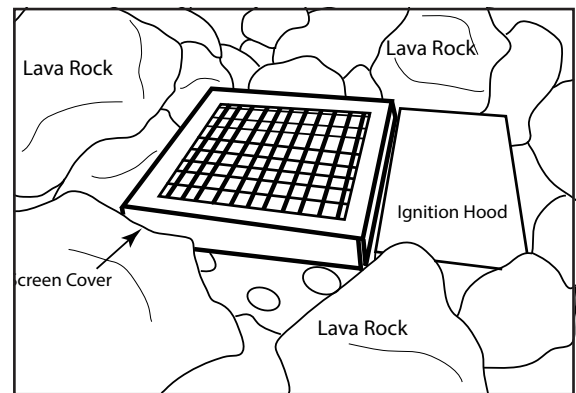

Fig. 10 Keep screen cover exposed

OPERATION

CAUTION: Children and adults should be alerted to the hazards on high surface temperatures and should stay away to avoid burns or clothing ignition. Young children should be carefully supervised when they are in the area of the appliance.

WARNING: Do not use this appliance if any part has been under water. Immediately call a qualified service technician to inspect the appliance and to replace any part of control system and any gas control, which has been under water.

SAFETY WARNINGS

1. Never leave the fire pit unattended during operation.
2. Clothing or other flammable materials should not be placed on or near the appliance.
3. Any guard or other protective device removed for servicing the appliance must be replaced prior to operating the appliance.
4. Installation and repair should be done by a qualified service person. The appliance should be inspected before use and at least annually by a qualified service person. More frequent cleaning may be required as necessary. It is imperative the control compartment, burners and circulating air passageways of the appliance be kept clean.
5. Inspect the fuel supply connection before each use of the appliance.
6. Temporary storage of this appliance indoors is permissible only if it has been disconnected from its fuel supply (Natural or LP gas line).

WARNING

1. This appliance is hot when operated and can cause severe burns if contacted.
2. Do not burn any solid fuels in this appliance.

READ ALL LIGHTING INSTRUCTIONS BEFORE ATTEMPTING TO LIGHT FIRE PIT

CAUTION: ENSURE YOU HAVE LEAK TESTED THE FIRE PIT BEFORE OPERATING.

WARNING: Do not stand over fire pit during ignition or operation due to high surface temperatures.

LIGHTING INSTRUCTIONS

TURNING ON FIRE PIT

1. Depress and hold the red Piezo ignitor button and ensure sparking is occurring at the probes inside ignition hood.
2. Rotate control knob on gas valve counter clockwise to the ON position.
3. Depress control knob inward to light the burner.
4. After the fire pit lights release the Piezo button but continue to depress the control knob for at least 30 seconds then release knob. If fire pit does not light within 30 seconds, release control knob, turn knob clockwise to turn OFF and wait 5 minutes before trying again. Turn gas supply OFF to check probe spacing and Piezo battery if fire pit does not light.
5. Repeat steps 1-4.

TURNING OFF FIRE PIT

1. Push the control knob slightly inward and turn clock wise until it stops at the OFF position. Fire pit will turn OFF.
2. After cooling off install lid (if applicable).

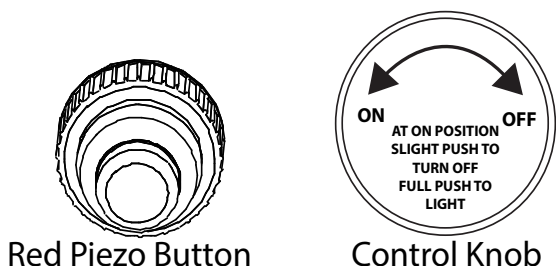

Fig. 11. Control knob and Piezo button

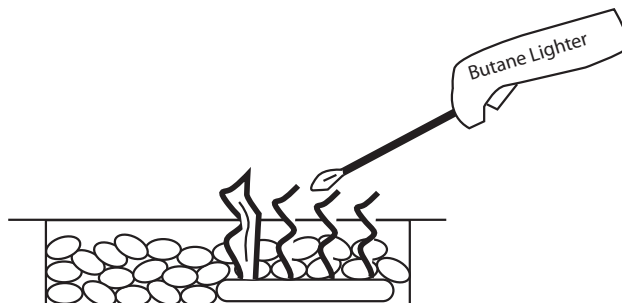

Fig. 12 Lighting with Butane lighter

FIRE PIT MAINTENANCE

1. The fire pit should be inspected and cleaned before initial use at least annually by a qualified field service person.
2. Any component that is found faulty must be replaced with an approved component.
3. Any tampering or modifying with the fire pit is dangerous and voids all warranties.
4. During winter months in cold climates and various seasons, operation of the fire pit may be affected by weather conditions. It is recommended to use a cover/lid over top of your fire pit to protect it from humid/rainy weather conditions when not in use. Heavy rains/downpours could affect the fire pit operation if not covered; if this occurs, ensure you allow the fire pit time to dry out before attempting to operate. **NOTE:** If a combustible type lid is used over the fire pit when not in use, be sure to remove lid before operating to prevent a severe safety hazard.
5. Carbon (soot) may build up on the surface of logs (if installed) during heavy use. Sooting may also occur periodically on the screen of the ignitor hood. To clean, brush off with a dry bristle brush or cloth. Keep soot away from clothing or furniture.
6. Over time stainless steel parts can discolor when heated, usually a golden or brown hue. This discoloration is normal and does not affect the performance of the appliance.

TMSI TROUBLE SHOOTING

<u>Symptom</u>	<u>Remedy</u>
Fire pit won't light	<ol style="list-style-type: none"> 1. Bleed gas line. 2. Ensure all gas supply lines are turned ON. 3. Ensure there is not too much media overtop of burner; it can inhibit gas from flowing.
Low Flame	<ol style="list-style-type: none"> 1. Ensure the base media is at least 1-inch in diameter and top media is no more than 1-inch over top of burner. 2. Ensure all shut-off valves and valve is fully open. . 3. Check for spider webs inside burner orifice.
Water in my fire pit	<ol style="list-style-type: none"> 1. Excess dust/sand material from media may be blocking the weep holes to relieve water. 2. Remove all media and unplug weep holes. Clean or install new media free of dust and dirt. 3. Ensure fire pit enclosure has proper drainage for water and proper ventilation to dry out. 4. Recommend to purchase a cover/lid to keep excessive water out of the fire pit.
Whistling Noises	<ol style="list-style-type: none"> 1. Check media to ensure it is not too tightly packed around the burner tube. 2. Ensure a non-whistling flex connector is being used.
Fire pit won't stay lit	<ol style="list-style-type: none"> 1. Check alignment of thermocouple over rainshield on page 11, Fig. 9. 2. Ensure thermocouple is not screwed too tight into gas valve. It should be finger tight plus a quarter turn with a wrench. 3. Ensure thermocouple is clean and free of any debris. Excessive soot can be an issue.

Expanded View of Thermocouple Manual Safety (TMSI) Fire Pit

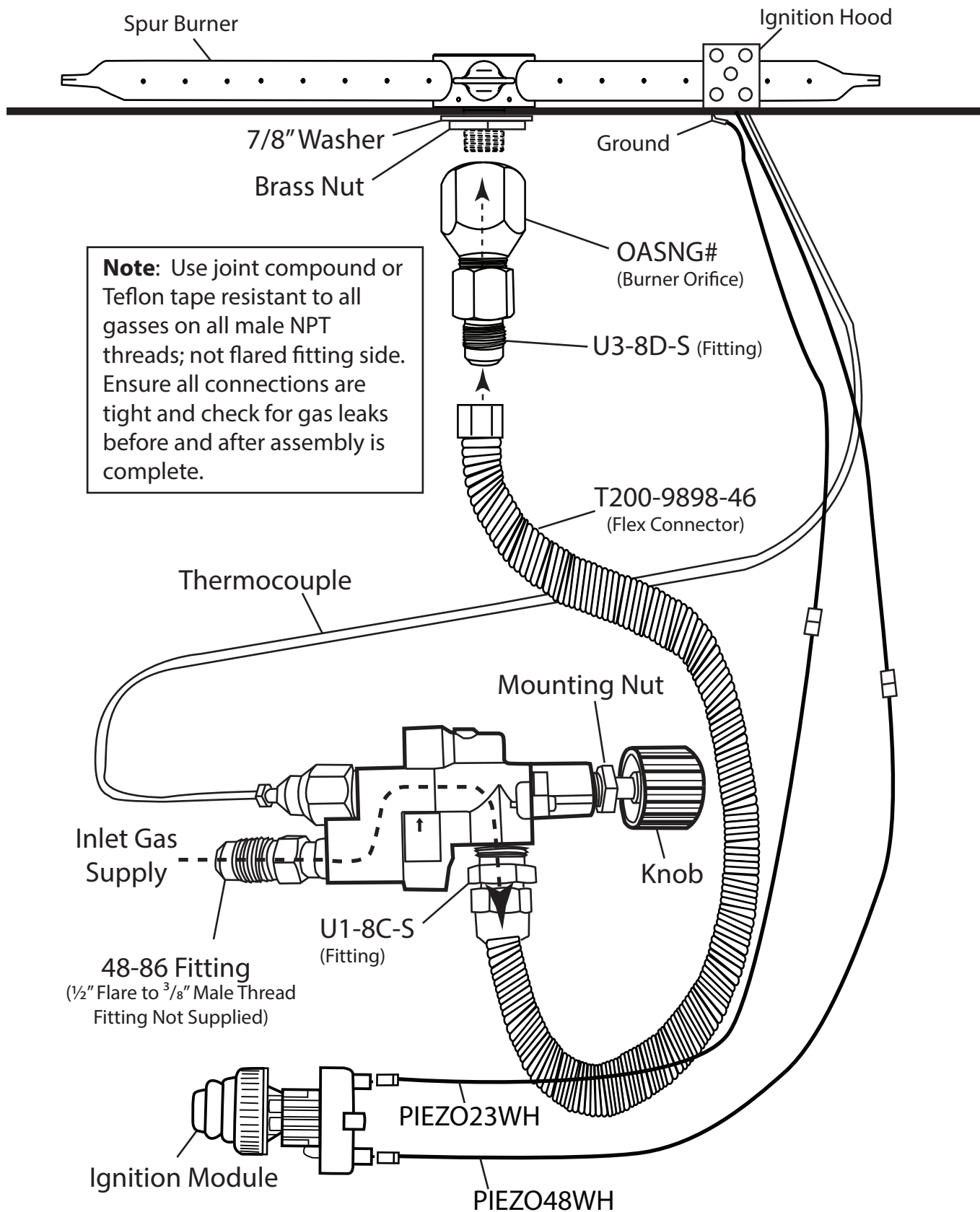

Note: Use joint compound or Teflon tape resistant to all gasses on all male NPT threads; not flared fitting side. Ensure all connections are tight and check for gas leaks before and after assembly is complete.

Section B

Thermocouple Flame Sense (TFS) Installation

Flat discs are typically used with landscape blocks. The illustrations below show examples of possible installations.

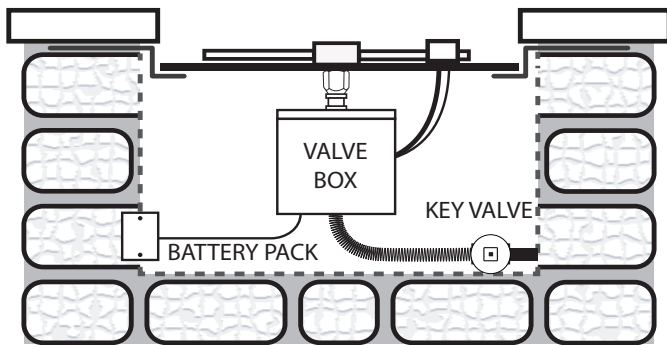

Fig. 13 Typical installation.

NOTE: Gas valve, flexible gas lines and TFS components are supplied. Gas shut-off is not supplied. Battery pack can be installed within the 12-foot wire length. If exposed to the elements a weather proof box is recommended.

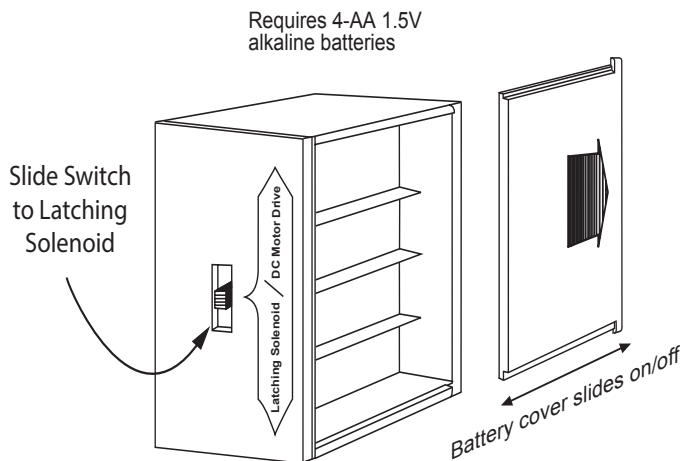

Fig. 14. Slide switch on latching solenoid

Install (4) AA batteries into the battery pack and ensure the slide switch is in the Latching Solenoid position on the front side.

Snap the battery pack into the cover plate then set it aside.

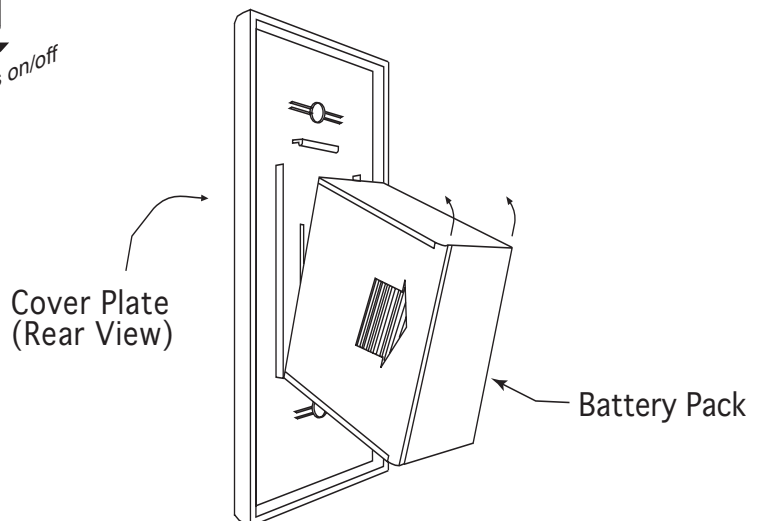

Fig. 15 Cover plate installation

INSTALLING BATTERY PACK INTO WEATHERPROOF BOX

After the weatherproof box location has been established and installed, run the black 4-PIN connector wire along with the red and black wires from the valve box into the weatherproof box. Connect red to red and black to black wires from the valve box to the wires of the battery pack. Connect the 4-PIN connector into the back of the battery pack.

Next, secure the battery pack into the weatherproof box as shown in Fig. 16

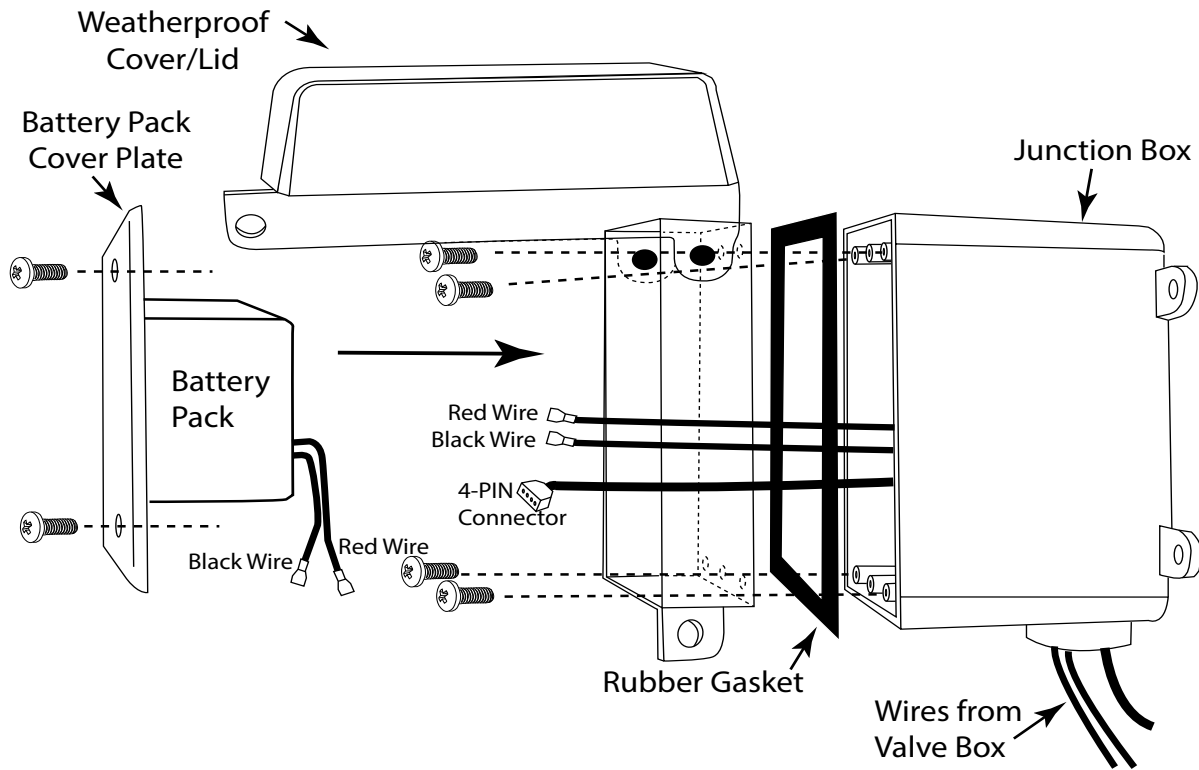

Fig. 16 Weatherproof cover/lid installation.

INSTALLATION OF BATTERY INTO TRANSMITTER

You have one handheld transmitter and you will need to install the included (12-volt battery) into the transmitter. Slide the battery cover off the case, on the backside of the transmitter. Place the battery into the compartment matching positive-to-positive and negative-to-negative. To ensure the battery is properly installed push any button on the transmitter and you will see a red LED light at the top of the transmitter glow. The red LED light will only be lit when a button is pushed. See Fig. 17.

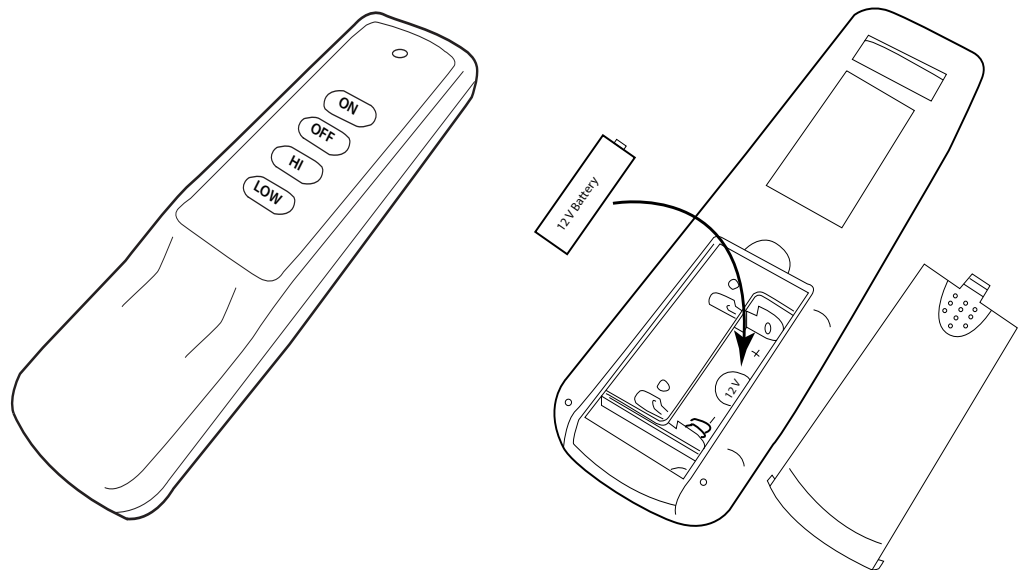

Fig. 17 Installing battery into transmitter.

LEARNING THE REMOTE CONTROL TO THE MODULE

This fire pit comes standard with one remote controlled transmitter. The handheld remote is shipped with this system already learned (programmed) to the module inside the control box. Additional transmitters can be learned to this electronic module; up to a total of three transmitters are available. Contact Firegear to discuss additional transmitter options or see the accessory page of this instruction manual.

Learning the new transmitters will require pressing the learn button on the module. You should learn any new transmitters before the final installation of the fire pit. Follow the steps below:

1. Remove the two screws securing the cover on the control box (See Fig. 18). The cover will slide down exposing the gas valve and control module.
2. Find the black module attached to the inside of the control box. Locate the "Learn Button" on the bottom of the module.
3. Once the Learn button is located, press and release the button once. You will hear a beep indicating that the module is ready to receive a transmitter code (See Fig. 19)
4. Take the transmitter and press the OFF button. You will hear a series of rapid beeps indicating the module has accepted the new code.

NOTE: A maximum of three (3) codes can be programmed to the module. After a total of three (3) codes have been programmed the memory is full and will not accept any additional codes. To clear all codes, press and hold the learn button for 10 seconds. The module will beep three (3) times indicating the memory is clear of all codes. After codes have been cleared see Step #3 above to re-learn transmitter.

INSTALLATION OF LAVA ROCK/MEDIA INTO BURNER PAN

Install lava rock/media into the burner pan. Ensure the media is a minimum of 1 to 2-inch diameter for proper operation. **Note:** Do not pour lava rock directly from bag. Media should be placed naturally and NOT packed in tight. Loose fitting is important to ensure robust flames. Be sure rocks are free of any excessive dust. This prevents the burner pan weep holes from being plugged and holding water. **IMPORTANT:** Do not place media over top or under the screen cover. The screen must be free of any debris to ensure proper lighting of burner and to allow proper heating of the thermocouple.

Cover the burner completely with media but do not make the depth greater than 1-inch over top of the burner portholes.

Decorative glass may be loosely scattered on top of the lava rock. Do NOT cover the stainless steel screen cover with any rock or glass. It must be free of any media/debris to operate properly.

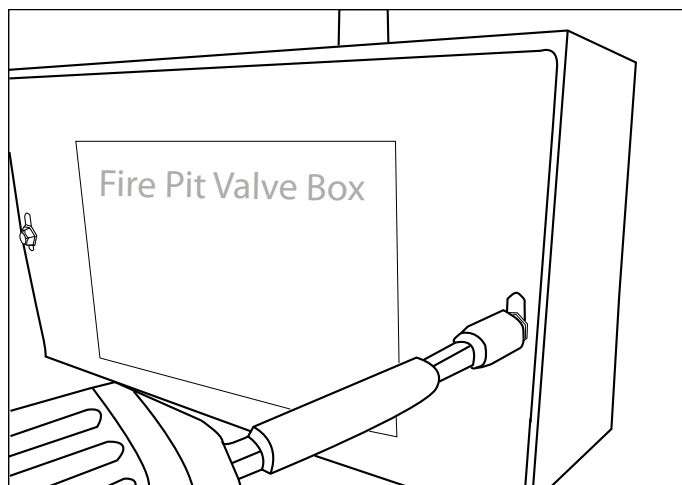

Fig. 18 Removing the cover from metal box.

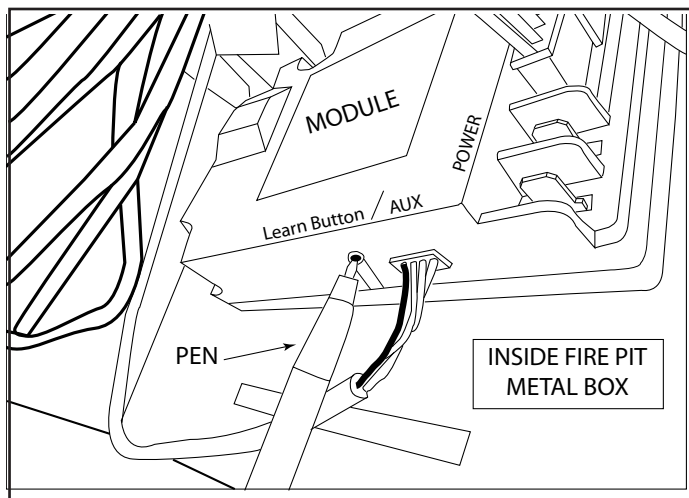

Fig. 19 Learn button location

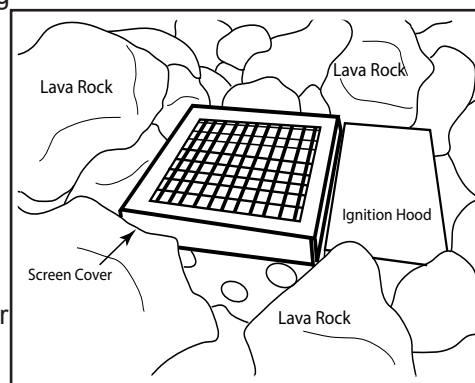

Fig. 20 Keep screen cover exposed

IGNITOR ALIGNMENT

It is important to check that the ignitor probes are properly aligned over top of the burner port holes and did not move during shipping. Use the Fig. 21 as a guide. Before lighting, remove the screen cover of the ignition hood to burner and ensure the spark probes are directly over top of a burner port hole. The sparking probes and the thermocouple must be in the path of a flame to ignite the gas for proper ignition of the flame. Replace the screen cover and follow the operating instructions.

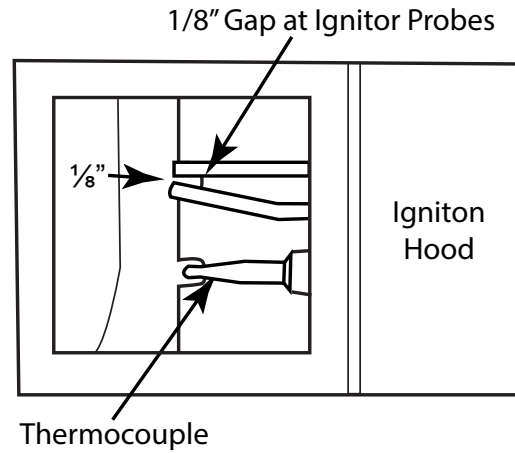

Fig. 21 Proper alignment of probes and thermocouple.

CONNECTING GAS SUPPLY Connect the gas supply line to the bottom of the valve box with the supplied flex connector as shown in Fig. 22 below. If necessary remove the lid for greater access to the connection. Ensure you have enough flex line available to pull the fire pit out of the enclosure if needed for maintenance or service. **NOTE:** If removing lid, ensure you slide the flex line through the lid access hole to enable you to reattach the lid.

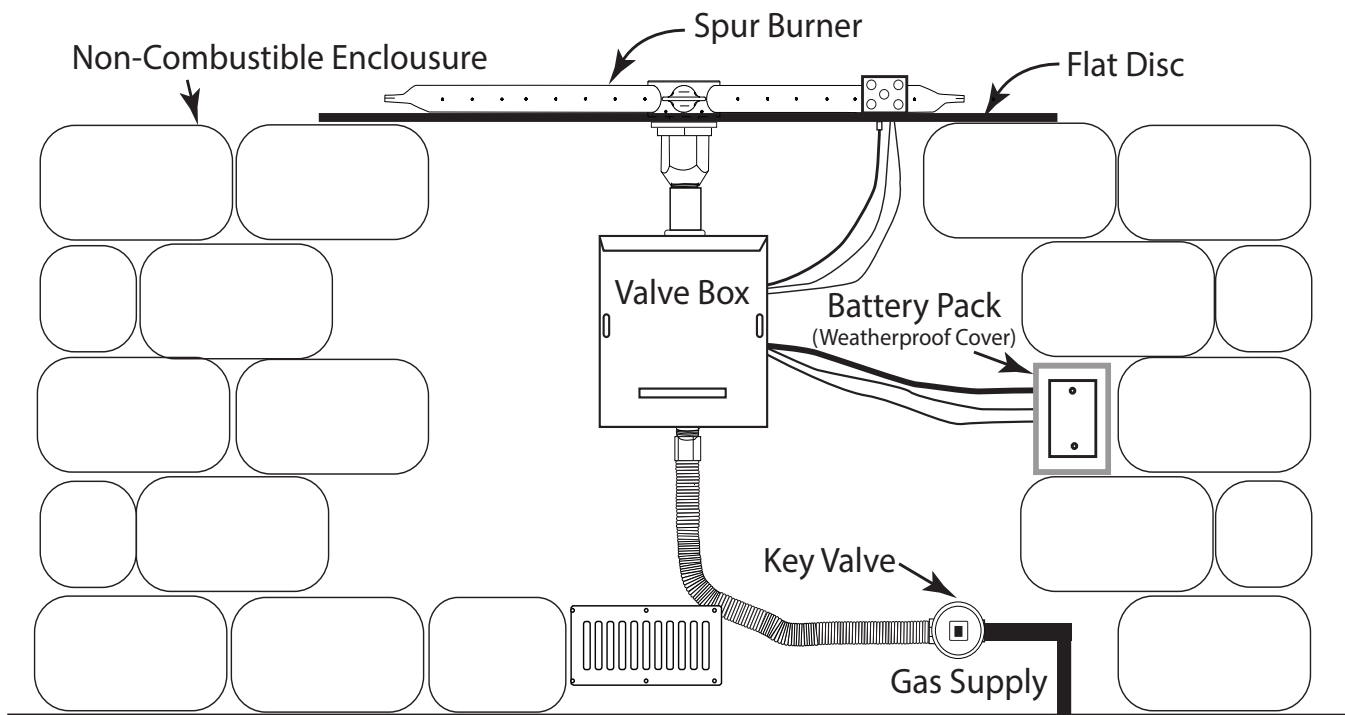

Fig. 22 Shows TFS system installed into an enclosure.

Gas valve and flexible gas lines are supplied; gas shut-off is not, but available in accessories page. Flex lines with flared fittings do not require Teflon tape or pipe compound. Ensure not to "kink" the flex lines to allow better gas flow of gas. The illustration above is only a guide for the gas connection. Local codes may require different methods to connect the gas supply.

OPERATION

CAUTION: Children and adults should be alerted to the hazards on high surface temperatures and should stay away to avoid burns or clothing ignition. Young children should be carefully supervised when they are in the area of the appliance.

WARNING: Do not use this appliance if any part has been under water. Immediately call a qualified service technician to inspect the appliance and to replace any part of control system and any gas control, which has been under water.

SAFETY WARNINGS

1. Never leave the fire pit unattended during operation.
2. Clothing or other flammable materials should not be placed on or near the appliance.
3. Any guard or other protective device removed for servicing the appliance must be replaced prior to operating the appliance.
4. Installation and repair should be done by a qualified service person. The appliance should be inspected before use and at least annually by a qualified service person. More frequent cleaning may be required as necessary. It is imperative the control compartment, burners and circulating air passageways of the appliance be kept clean.
5. Inspect the fuel supply connection before each use of the appliance.
6. Temporary storage of this appliance indoors is permissible only if it has been disconnected from its fuel supply (Natural or L.P. gas line).

WARNING

1. This appliance is hot when operated and can cause severe burns if contacted.
2. Do not burn any solid fuels in this appliance.

LIGHTING INSTRUCTIONS

READ ALL WARNING AND SAFETY INFORMATION ABOVE BEFORE ATTEMPTING TO LIGHT FIRE PIT

TURNING ON FIRE PIT

1. Ensure you have leak tested the fire pit before operating. Turn main gas supply ON.
2. Ensure batteries are installed in battery pack and switch is on Latching Solenoid.
3. Press the **ON** button on the transmitter (Fig. 23) You will hear the ignitor probe begin sparking for 15-seconds and the fire pit will turn ON.
4. If the fire pit does not light the module will “beep” one time every second indicating an ignition error. This is a hard lockout. If this occurs press the **OFF** button on the remote control and repeat step 1-3.
5. If fire pit does not light after second try, turn main gas OFF, wait 5 minutes and repeat steps 1-3.

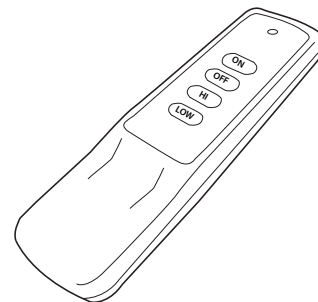

Fig. 23 Transmitter

NOTE: It may take several cycles of ON/OFF to purge the airflow from the gas lines. The direct spark ignition will turn OFF after 15 seconds. If the burner does not light, you will need to press the OFF button on the transmitter then then ON again to initiate ignition.

Flame height is HI and LO. By pressing the buttons on the handheld transmitter you can operate ON-OFF-HI-LO. The transmitter defaults to the HI setting when initially lighting the fire pit each time but will remember the last setting used and change back to that last setting in approximately 5 seconds after lighting.

TURNING OFF FIRE PIT

1. To turn OFF the fire pit, press the OFF button on the transmitter. Fire pit will turn OFF.
2. After fire pit has completely cooled off, install cover.

TROUBLE SHOOTING FOR TFS MODELS

FAULT CODES

The VCS-5000MODTC control module has built-in error detection for several common operating fault conditions. When the control module detects an error, it will emit a series of beeps. The beeping pattern will help to determine the cause of the operating fault.

SECTION B THERMOCOUPLE FLAME SENSE (TFS) INSTALLATION

Ignition Safety (Protection for ignition system):

Error Code: One beep every one second.

Description of Fault: Warn users if the pilot is not successfully ignited in 15 seconds.

How to Clear: Press OFF then ON buttons to re-attempt ignition.

What to Check:

1. Ensure gas supply is turned on.
2. Ensure that the gas line is purged of air. Air is common in the gas line if the appliance has just been installed, has been disconnected then re-connected to the gas line, or if the appliance has been unused for an extended period of time.
3. Ensure there is no blockage in the gas line.
4. Make sure that the flame sensor electrode is clean. Soot buildup will insulate the electrode and will not allow for proper flame sensing.
5. Ensure orange/white leads from module are plugged into the "PILOT" connection on the valve body.
6. Ensure green/white leads from module are plugged into the "MAIN" connection on the valve body.
7. Verify lead from igniter on electrode assembly is connected to the "I" terminal on the module.
8. Verify lead from flame sensor on electrode assembly is connected to the "S" terminal on the module.
9. Verify that the black ground lead from the module is connected to a proper ground on the appliance.

Sensor Safety (Protection for flame sensor):

Error Code: 4 Beeps every one second (Constant beeping)

Description of Fault: Warn users the flame sensor detects a flame already present when ignition sequence is initiated. This fault will also occur if the flame sensor is shorted to ground.

How to Clear: Press OFF then ON buttons to re-attempt normal ignition.

What to Check:

1. Check if flame is actually present when valve is turned OFF (if so, replace valve).
2. Ensure that the flame sensor electrode is not touching the burner or another metal surface.
3. Check to ensure ground wire from thermocouple and module is connected to gas valve.
4. If 3-probe ignitor is exposed to excessive moisture/water it will need 24-48 hours to dry out.
5. Replace electrode assembly.
6. Replace module.

Thermal Safety (Overheat Protection):

Error Code: 4 Beeps every 2 seconds.

Description of Fault: Warn users that the module's internal temperature exceeds 170°F.

How to Clear: Module's internal temperature must cool to below 160°F and then press ON button.

What to Check:

1. Ensure that there is proper ventilation to the control module.
2. Is module located in unapproved location, too close to burner?
3. Move to cooler location.

Wireless Remote Transmitter Will Not Operate Appliance

Make sure that the transmitter is within the 25-foot operational range of the control module.

1. Ensure batteries in transmitter are fully charged and properly installed.
2. If using the battery pack, ensure batteries are fully charged and properly installed. Also, make sure the battery pack's 4-pin connector is securely connected to the battery pack and control module.
3. If using optional AC adapter, ensure that the AC adapter leads are securely attached to "POWER" connection on the control module. Also, ensure that the AC adapter is connected to a live 120VAC power source.
4. Ensure "Remote/Off" switch on control module is set to "Remote".
5. Ensure the control module has learned the transmitter's security code (learning section page 17).
6. Make sure that the remote transmitter is not placed/mounted to a metal surface, which will reduce the operating range.
7. Make sure that there is not a large metal obstruction between the remote transmitter and the control module.

Igniter Electrode Sparks Frequently During Operation

1. The control module will generate a spark at the igniter electrode if the system is in the ON position, but does not sense a flame.
2. Make sure that the flame sensor electrode is clean. Soot buildup will insulate the electrode and will not allow for proper flame sensing.
3. Make sure that wind does not blow the flame off of the flame sensor. The sensor hood and the appliance media (rocks, glass, etc.) provides shielding from the wind. Ensure that the sensor hood and appliance media is properly positioned per the appliance instructions. If wind is too strong, and the flame will not maintain contact with the flame sensor, the appliance should not be operated.

Flame Modulation Will Not Work or Works Backwards

1. Ensure that the black and red leads from the battery pack are securely connected to the red and black leads from the Hi/Lo latching solenoid located on the valve body (red to red and black to black).
2. Verify that the selector switch on the battery pack is set to LATCHING SOLENOID only.
3. Check functionality with all transmitters to determine if there is an issue with the main control system or an individual transmitter. If the issue is with an individual transmitter, make sure that the batteries in both the transmitter and battery pack are installed properly and fully charged.

Fig. 24 Wiring Diagram

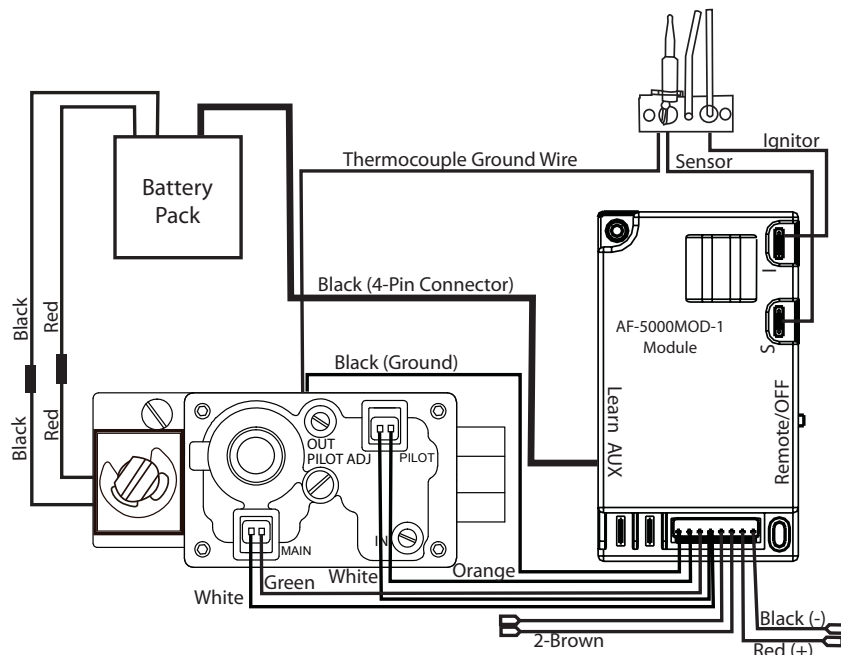

ADDITIONAL TROUBLE SHOOTING

Symptom	Remedy
Fire Pit Won't Light	<ol style="list-style-type: none"> 1. Bleed gas line. 2. Ensure all gas lines are turned ON. 3. Ensure there is not too much media over top the burner, it can inhibit the gas flow. Too little or no media can also contribute to non-lighting. 4. Check alignment of thermocouple (TC) over rainshield on page 17, Fig. 19. Adjust if needed. 5. Check batteries in battery pack. Minimum total voltage to operate should be 5.3 volts.
No Spark to Ignite	<ol style="list-style-type: none"> 1. Visually look at ignitor for any physical damage. 2. Ensure batteries are not installed backwards in battery pack. Check min. voltage of 5.3 volts. 3. Ensure battery in transmitter is not installed backwards and at minimum voltage of 9.0 DCV.
Continues to Spark after Lighting	<ol style="list-style-type: none"> 1. Thermocouple out of alignment. 2. Check connection of thermocouple at "S" terminal on control module to ensure it is connected.
Low Flame	<ol style="list-style-type: none"> 1. Ensure the base media is at least 1 to 2-inch in diameter and top media is no more than 1-inch over top of burner. 2. Ensure all shut-off valves and valve is fully open. 3. Check for spider webs inside burner orifice.
Water in my Fire Pit	<ol style="list-style-type: none"> 1. Excess dust/sand material from media may be blocking the weep holes to relieve water. Remove all media and unplug weep holes. Clean or install new media free of dust and dirt. 2. Ensure fire pit enclosure has proper drainage for water and proper ventilation to dry out. 3. Recommend to purchase a cover/lid to keep excessive water out of the fire pit.
Whistling Noises	<ol style="list-style-type: none"> 1. Check media to ensure it is not too tightly packed around the burner tube. 2. Ensure a non-whistling flex connector is being used.
Fire Pit Won't Stay Lit	<ol style="list-style-type: none"> 1. Check alignment of thermocouple over rainshield on page 17, Fig. 19. 2. Thermocouple reading should be between 10-20mV. Test at the brass ground lead on gas valve and the gold lead at "S" terminal on the control module. If no minimum millivolts are maintained replace the TC. 3. Check continuity of thermocouple. Using a volt meter, remove the TC test lead "S" from the control module and the brass fork terminal from the gas valve. Test for continuity. If no continuity then replace the TC. 4. Ensure thermocouple is clean and free of any debris. Excessive soot can be an issue.

FIRE PIT MAINTENANCE

1. The fire pit should be inspected and cleaned before initial use at least annually by a qualified field service person.
2. Any component that is found faulty must be replaced with an approved component.
3. Any tampering or modifying with the fire pit is dangerous and voids all warranties.
4. During winter months in cold climates and various seasons, operation of the fire pit may be affected by weather conditions. It is recommended to use a ventilated cover over top of your fire pit to protect it from humid/rainy weather conditions when not in use. Heavy rains/downpours could affect the fire pit operation if not covered; if this occurs ensure you allow the fire pit time to dry out before attempting to operate. **NOTE:** If a combustible type cover is used over the fire pit when not in use be sure to remove it before operation to prevent a severe safety hazard.
5. Carbon (soot) may build up on the surface of logs (if installed) during heavy use. Sooting may also occur periodically on the screen of the ignitor hood. To clean, brush off with a dry bristle brush or cloth. Keep soot away from clothing or furniture.
6. Over time stainless steel parts can discolor when heated, usually a golden or brown hue. This discoloration is normal and does not affect the performance of the appliance.

Expanded View of Thermocouple Flame Sense (TFS) Fire Pits

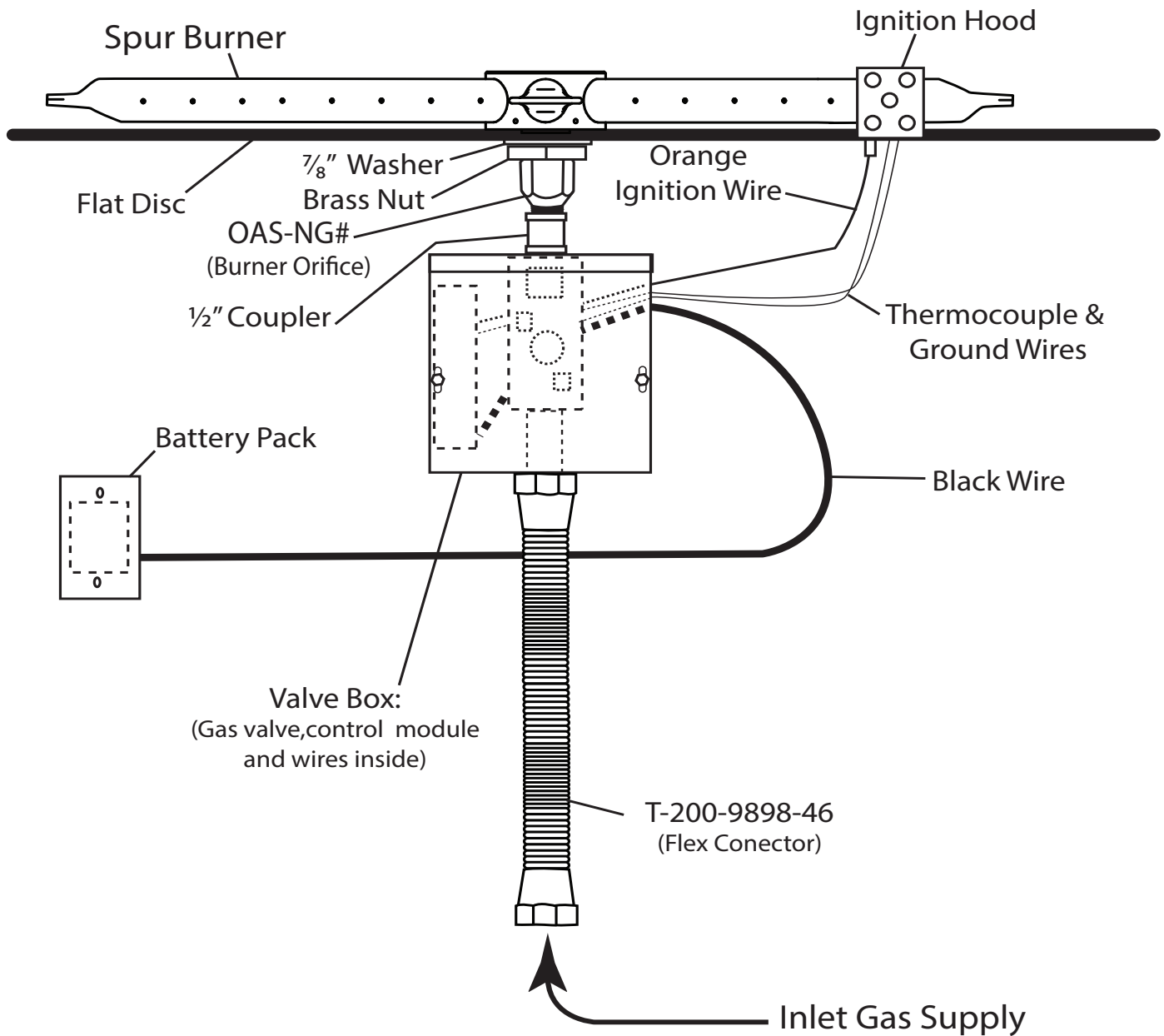

Note: Use joint compound or Teflon tape resistant to all gasses on all male NPT threads; not flared fittings. Ensure all connections are tight and check for gas leaks before and after assembly is complete.

ROUND FLAT DISC REPLACEMENT PARTS

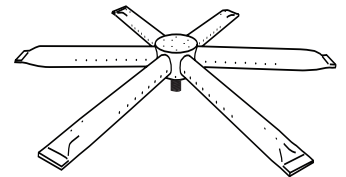
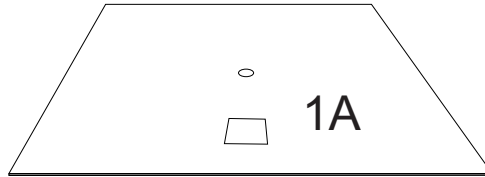
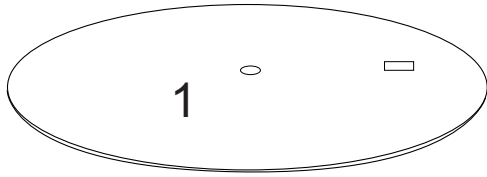

2

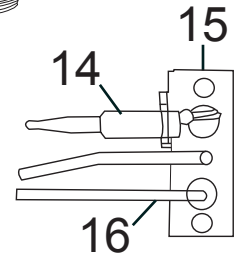
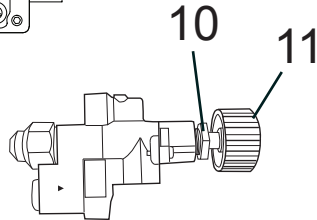
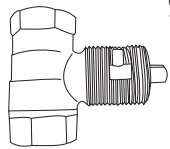
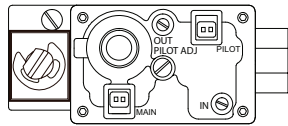
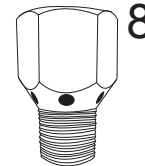
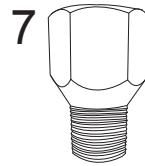
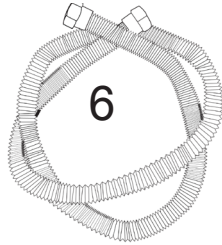
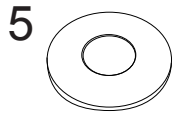
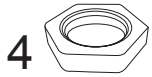

Drawings are not to scale

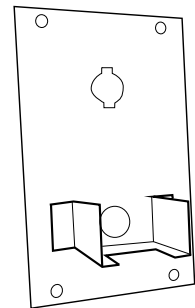
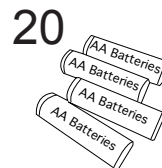
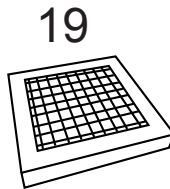
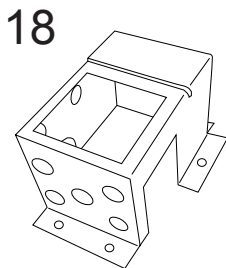
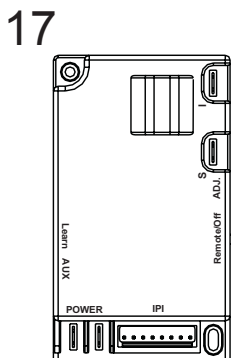

21

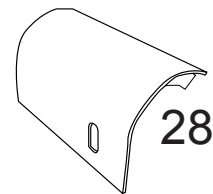
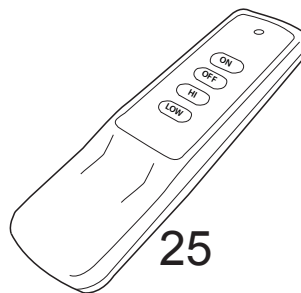
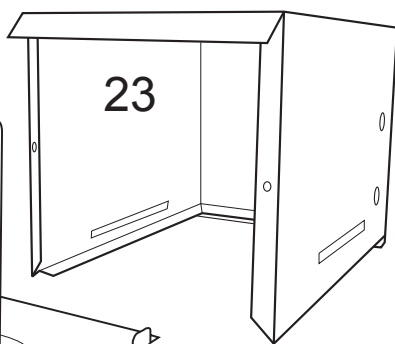
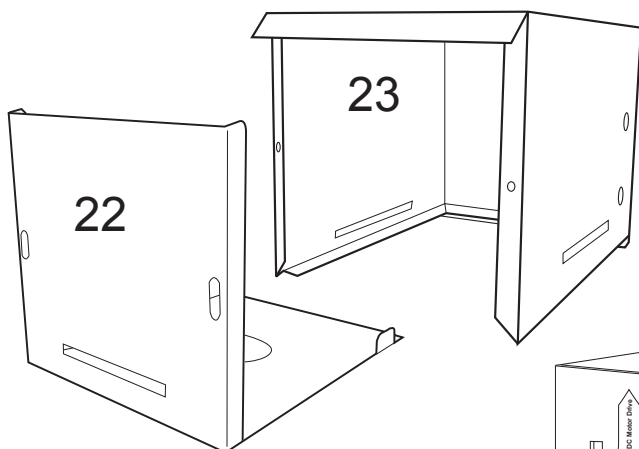

28

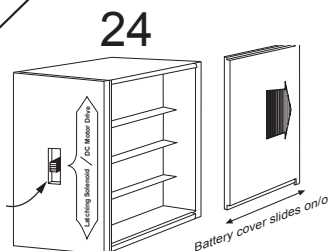

29

30

31

ROUND FLAT DISC REPLACEMENT PARTS LIST

Item	Description	Qty.	Part Number	TMSI	TFS
1	26-inch Round Flat Stainless Disc	1	PAN-SS26D	x	
1	29-inch Round Flat Stainless Disc	1	PAN-SS29D	x	x
1	34-inch Round Flat Stainless Disc	1	PAN-SS34D	x	x
1A	25-inch Square Flat Stainless Disc	1	PAN-SS25SF	x	x
1A	30-inch Square Flat Stainless Disc	1	PAN-SS30SF	x	x
1A	34-inch Square Flat Stainless Disc	1	PAN-SS34SF	x	x
2	22-inch Burning Spur (used in all flat pan disc's)	1	B-SPUR-22	x	x
4	1/2" NPS Brass Mounting Nut	1	105-8	x	x
5	7/8" Flat Washer/Spacer	1	ST3-113-1026	x	x
6	1/2" Flex Gas Line (46-inch Length)	1	T-200-9898-46	x	x
7	Orifice Air Shutter NG (Used on TMSI Natural models)	1	OAS-NG29	x	x
8	Orifice Air Shutter LP (Used on TMSI Propane models)	1	OAS-LP41	x	x
8	Orifice Air Shutter NG (Used on TFS Natural models)	1	OAS-NG7		x
8	Orifice Air Shutter LP (Used on TFS Propane models)	1	OAS-LP31		x
9	Electronic IPI Gas Valve with Solenoid	1	AF-4026		x
9	Manual Gas Valve (TMSI)	1	ST3-080-1009	x	
10	Gas Valve Mounting Nut (used with TMSI valve)	1	ST3-110-1005	x	
11	Manual Gas Valve Control Knob	1	ST3-050-1024	x	
12	Chrome Plated Key	1	KEY-PC-12		
13	Chrome Cover Plate	1	CVR-BVL2CP		
14	Thermocouple for TFS Pilot (Must be ordered with item #15)	1	ST3-040-1023		x
14	Thermocouple for TMSI Pilot	1	ST3-040-1025	x	
15	Thermocouple Bracket (Must be ordered with TFS item #14)	1	ST3-100-1054		x
16	Ignitor Probes	1	VCS-5000DSI2P01		x
17	Ignition Module	1	VCS-5000MODTC		x
18	Ignition Hood for Spur Burner	1	SPURHOOD	x	x
19	Mesh Screen Cover	1	ST3-100-1027	x	x
20	AA Batteries 1.5 Volt (used in battery pack)	4	BATTAA		x
21	Valve Mounting Plate (used with item #9)	1	TMSIFACEPLATE	x	
22	Valve Box Stainless Steel Lid	1	ST3-100-1033		x
23	Valve Box Stainless Steel		ST3-100-1034		x
24	Battery Pack (with 12-foot 4-Pin, 4-wire harness, cover plate and 12-foot red & black 2-wire harness for solenoid)	1	AF-4000BP12		x
25	ON/OFF HI/LO Transmitter	1	RCAF-3TXUNF		x
26	Transmitter Battery (not shown)	1	BATT12VOLT		x
27	Stainless Thread Cutting Screws #10-24x 1/2" (not shown)	4	10420		x
28	Rain Shield	1	RAINSHIELD	x	x
29	#10-24 x 1.25" Black Oxide Phillips Screw	4	SCREW1024PANBL	x	
30	#10-24 Stainless Nut	4	ST3-113-1020	x	
31	#10 Stainless Flat Washer	1	WASHER10SS	x	
32	Gas Valve 8-Pin Wiring Harness (not shown)	1	AF-40008PIN12WH/2		x
33	Weatherproof Junction Box with Tabs (not shown)	1	WP-JBOX		x
34	12-inch, 8-Pin Wire Harness (not shown)	1	ST3-042-1001		x
35	1/2" NPT Male to Male Close Nipple (not shown)	1	ST3-093-1025		x

ROUND FLAT DISC REPLACEMENT PARTS LIST

Item	Description	Qty.	Part Number	TMSI	TFS
36	1/2" Stainless Steel Coupler (not shown)	1	SS499-8		x
37	Thermocouple/Ignitor/Rainshield Replacement Kit (not shown)	1	TFS-IGNT-ASSEMBLY		x
38	Thermocouple/Rainshield Replacement Kit (not shown)	1	TMS-TC-ASSEMBLY	x	
39	Manual Spark Ignitor Module (not shown)	1	3042-RB	x	
40	23" Piezo Extension wire - See page 16 (not shown)	1	PIEZO23WH	x	
41	48" Piezo Extension wire - See page 16 (not shown)	1	PIEZO48WH	x	
42	Ground tab for Piezo ignition (not shown)	1	GROUNDTAB	x	
43	Weatherproof Cover/lid (not shown)	1	WP-COVER		x
44	6-32 x 1" Flat Head Phillips Screw - Holds WP Lid to WP-JBOX (not shown)	4	SCREW6-32X1PHFHZ		x
45	5½" x 3" TMSI & TFS cover plate (not shown)	1	PLATE-TFS/TMSI	x	x

FOR TECHNICAL SERVICE, CALL: (800) 966-8126



Firegear Outdoors
17322 Gothard St
Huntington Beach, CA 92647
Web Site: www.firegearoutdoors.com

Manual changes often occur, ensure to check the Firegear Outdoor website for any recent updates and warranty information.

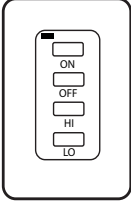
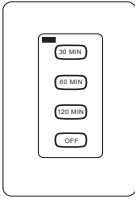
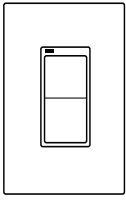

OPTIONAL ACCESSORIES

The following accessories are available from your local Firegear dealer/distributor.
Each accessory comes with a separate installation manual. Read each instruction thoroughly before installing.

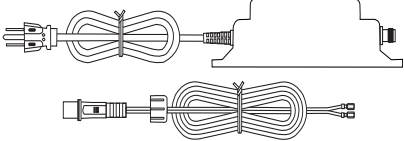
<p style="text-align: center;"><u>Media</u></p> <p><i>Lava Stones: 1" to 2" size (50 lbs)</i> Model: FG-LS-50 (bag)</p>	<p style="text-align: center;"><u>Media</u></p> <p><i>Lava Boulders: 6" to 12" size (30lbs)</i> Model: FG-LB30 Box</p>	<p style="text-align: center;"><u>Media</u></p> <p><i>Lava Rock: 1" to 1½" size</i> Model: FG-LAVA-50 (bag) Model: FG-LAVA-10 (bag)</p>
<p style="text-align: center;"><u>Wireless Wall Switch</u></p>  <p>ON/OFF/HI/LO (TFS models only) Model: 1322-WT</p>	<p style="text-align: center;"><u>Wireless 4-button Timer</u></p>  <p>30/60/120/OFF (TFS models only) Model: TMR-AF1</p>	<p style="text-align: center;"><u>Wireless Wall Switch</u></p>  <p>ON/OFF (TFS models only) Model: 1001D-AF1-TX</p>
<p style="text-align: center;"><u>LP Conversion Kit</u></p> <p>For use with listed models below. Kit Includes: OAS, rating plate sticker and instructions. Model: LPK#41</p> <p>For Use With Models:</p> <p>FPB-25SFBSTMSI-N FPB-26DBSTMSI-N FPB-29DBSTMSI-N FPB-30SFBSTMSI-N FPB-30DBSTMSI-N FPB-34DBSTMSI-N</p>  <p>NOTE: There is no LP conversion kit for Thermocouple Flame Sense (TFS) models. You must order Propane models directly from the factory.</p>	<p style="text-align: center;"><u>Shut-Off Valves</u></p> <p>Model: 01-387 ⅜" OD Flare x ½" FIP Model: 01-487 ½" OD Flare x ½" FIP Model: 01-266 ⅜" OD Flare x ⅜" OD Flare Model: 01-288 ½" OD Flare x ½" OD Flare</p> <p style="text-align: center;"><u>Adapter</u></p> <p>Model: ADP10-OUT (10' wire)</p>  <p>Outdoor approved 7.5VDC adapter/transformer eliminates the use of battery power with any TFS system.</p>	<p style="text-align: center;"><u>Home Automation System</u></p> <p>A transmitter compatible with home automation systems using dry contacts to operate fire pit. Model: AF4000HAT</p> <p style="text-align: center;"><u>Vent Kits</u></p> <p>Provide 18 sq. in of ventilation per side of enclosure)</p> <p>Model: VENT-KIT-6X12SS Model: PAVER-VENT-4LNTS Model: PAVER-VENT-6LNTS</p> <p style="text-align: center;"><u>Paver Control Panels</u></p> <p>PAVER-CP-TMSI TMSI systems</p>
<p style="text-align: center;"><u>Log Sets</u></p> <p>Model: L-SF (Spit Fire) - 17pc (52lbs) L-BF (Beach Fire) 8pc (20lbs) L-Sedona (Sedona) 19pc (200lbs) 326-930 Twigs 6pc (20lbs)</p>	<p style="text-align: center;"><u>E-STOP</u></p> <p>Mechanical gas timer valve with emergency shut-off.</p> <p>Model: ESTOP1-0H 1hr. timer Model: ESTOP2-5H 2.5hr. timer * Not for use with TFS fire pit systems</p>	<p style="text-align: center;"><u>FLEXFRAME</u></p> <p>44" Universal brackets to support fire pit disc when using paver blocks or other non-combustible enclosures.</p> <p>Model: FLEXFRAME-SS (2pc) FLEXFRAME-SS3 (3pc)</p>
<p style="text-align: center;"><u>Lids</u></p> <p><i>Stainless Round Lids</i> Models: LID-25R, LID-29R2, LID33R2</p>	<p style="text-align: center;"><u>Lids</u></p> <p><i>Stainless Square Lids</i> Models: LID-26S, LID-32S</p>	

NOTE: See the Firegear Outdoors catalog for other optional accessories.

FIREGEAR LIMITED WARRANTY - 2020

Firegear Outdoors hereby warrants to the end user that products will be free from material and workmanship defects that prevent safe and correct operation of the product. The warranty commences from date of sale to the end user for the following period:

CONSUMER RESIDENTIAL APPLICATIONS – MANUFACTURED AFTER 12/02/2019

BURNER SYSTEMS, BURNERS, COMPONENTS AND ACCESSORIES

- LIFETIME WARRANTY ON CONSTRUCTION AND MANUFACTURER DEFECTS
- LIFETIME WARRANTY - STAINLESS STEEL BURNERS AND PANS
- LIFETIME WARRANTY - BRASS BURNERS
- FIVE (5) YEAR WARRANTY - GAS VALVE, SPARK IGNITER, PILOT ASSEMBLIES
- FIVE (5) YEAR WARRANTY - AWS ELECTRONIC IGNITION SYSTEMS (24VAC, 30 VDC)
- FIVE (5) YEAR WARRANTY - TFS/TMSI ELECTRONIC COMPONENTS
- FIVE (5) YEAR WARRANTY – MT COMPONENTS (KEY VALVE)
- FIVE (5) YEAR WARRANTY - REFRACTORY GAS LOG SETS
- FIVE (5) YEAR WARRANTY - READY TO FINISH/ANF FIRE PIT ENCLOSURES
- FIVE (5) YEAR WARRANTY – SKYTECH MANUFACTURED OPTIONAL CONTROLS

OUTDOOR FIREPLACE – KALEA BAY

- LIFETIME WARRANTY - CONSTRUCTION AND MANUFACTURER DEFECTS
- LIFETIME WARRANTY - STAINLESS STEEL COMPONENTS
- FIVE (5) YEAR WARRANTY - GAS VALVE, PILOT ASSEMBLY, POWER SUPPLY, CONTROLS
- FIVE (5) YEAR WARRANTY – SKYTECH MANUFACTURED OPTIONAL CONTROLS

SANCTUARY SERIES – GFRC FIRE FEATURES

- THREE (3) YEAR WARRANTY - GFRC STRUCTURE
- REFER TO THE APPROPRIATE BURNER SYSTEM FOR WARRANTY

WARRANTY COVERS MANUFACTURING DEFECTS OR STRUCTURAL FAILURE. SMALL STRESS CRACKS AND SURFACE CRAZING ARE A NATURAL OCCURRENCE IN GFRC PRODUCTS AND NOT COVERED BY WARRANTY.

READY TO FINISH/ANF ENCLOSURES

- FRAME – LIFETIME WARRANTY ON CONSTRUCTION AND MANUFACTURER DEFECTS

ACCESSORIES

- LIFETIME WARRANTY - CONSTRUCTION AND MANUFACTURER DEFECTS
- LIFETIME WARRANTY - STAINLESS STEEL COMPONENTS (LIDS, STAINLESS STEEL COVERS)
- ONE (1) YEAR WARRANTY – ESTOP1-OH, ESTOP2-5H WINDSHIELDS, HOSES AND REGULATORS



COMMERCIAL APPLICATIONS – MANUFACTURED AFTER 12/02/2019

BURNER SYSTEMS, BURNERS, COMPONENTS AND ACCESSORIES

- TWO (2) YEAR WARRANTY ON CONSTRUCTION AND MANUFACTURER DEFECTS
- TWO (2) YEAR WARRANTY - STAINLESS STEEL BURNERS AND PANS
- TWO (2) YEAR WARRANTY - BRASS BURNERS
- TWO (2) YEAR WARRANTY - GAS VALVE, SPARK IGNITER, PILOT ASSEMBLIES
- TWO (2) YEAR WARRANTY - AWS ELECTRONIC IGNITION SYSTEMS (24VAC, 30 VDC)
- TWO (2) YEAR WARRANTY – MT COMPONENTS (KEY VALVE)
- TWO (2) YEAR WARRANTY - REFRACTORY GAS LOG SETS
- FIVE (5) YEAR WARRANTY - READY TO FINISH/ANF FIRE PIT ENCLOSURES
- TWO (2) YEAR WARRANTY – SKYTECH MANUFACTURED OPTIONAL CONTROLS

OUTDOOR FIREPLACE – KALEA BAY

- LIFETIME WARRANTY - CONSTRUCTION AND MANUFACTURER DEFECTS
- LIFETIME WARRANTY - STAINLESS STEEL COMPONENTS
- TWO (2) YEAR WARRANTY - GAS VALVE, PILOT ASSEMBLY, POWER SUPPLY, CONTROLS
- TWO (2) YEAR WARRANTY – SKYTECH MANUFACTURED OPTIONAL CONTROLS

SANCTUARY SERIES – GFRC FIRE FEATURES

- THREE (3) YEAR WARRANTY - GFRC STRUCTURE
- REFER TO THE APPROPRIATE BURNER SYSTEM FOR WARRANTY

WARRANTY COVERS MANUFACTURING DEFECTS OR STRUCTURAL FAILURE. SMALL STRESS CRACKS AND SURFACE CRAZING ARE A NATURAL OCCURRENCE IN GFRC PRODUCTS AND NOT COVERED BY WARRANTY.

READY TO FINISH/ANF ENCLOSURES

- FRAME – LIFETIME WARRANTY ON CONSTRUCTION AND MANUFACTURER DEFECTS

ACCESSORIES

- LIFETIME WARRANTY - CONSTRUCTION AND MANUFACTURER DEFECTS
- LIFETIME WARRANTY - STAINLESS STEEL COMPONENTS (LIDS, STAINLESS STEEL COVERS)
- ONE (1) YEAR WARRANTY – ESTOP1-OH, ESTOP2-5H WINDSHIELDS, HOSES AND REGULATORS

The end-user must provide a bill of sale, canceled check, or payment record to verify the purchase date and to establish the warranty period. This Limited Warranty shall be valid and limited to the original purchaser only.

WARNING Any modification to the product will void the warranty.

This Limited Warranty shall be limited to the repair and/or replacement of parts that have been proven to be defective under normal use and service. All warranty claims must be made by the OEM/Distributor/Dealer account on behalf of the end-user. You may contact Technical Support at 800-966-8126.

Our Technical Service Department must confirm all approved defects. If a defect is confirmed and we approve the claim, we will replace such parts without charge. This warranty gives you specific legal rights, and you may also have other rights, which vary from state to state.

The manufacturer may request defective products returned with an RMA (Return Merchandise Authorization) issued by Firegear Outdoors for specific products, which is considered to be the nature of the defect and or warranty claim. Product to be returned should; be packed so as not to incur damages during transportation. Firegear is not responsible for damages on returned items. RMA is valid for thirty (30) days from the date issued. The RMA must be clearly marked on the outside of the package.

Please check with your local building code department or governing agency for proper approvals before purchasing. Firegear Outdoors is not responsible for any violation of local codes.

Travel, diagnostic cost, service labor to repair the defect on warranty parts to and from the factory will be the responsibility of the owner. We will not be responsible for labor charges and/or damage incurred in installation, repair, and replacement. Firegear is not responsible for Issues related to gas or electrical installation.

The Limited Warranty is voided if not assembled, installed, and operated as intended. This Limited Warranty does not cover any defects due to accident, abuse, misuse, alteration, misapplication, vandalism, improper installation or improper maintenance or service, removal from the original location, or re-installation into another location, or failure to perform normal and routine maintenance.

Damage due to severe weather conditions such as hail, hurricanes, earthquakes, tornadoes, discoloration due to overheating, exposure to chemicals (including chlorine and salt), either directly or in the atmosphere, or very high humidity, is not covered by this Limited Warranty. Coastal, humid and/or salt environments are subject to manufacturer review. All out-of-box claims must be made within 30 days of purchase and must be made prior to installation. Any product installed damaged will be considered damaged during installation and not covered under warranty.

There are no other express warranties except as set forth herein. For consumer applications, any applicable implied warranties of merchantability and fitness are limited in duration to the period of coverage of this Limited Warranty. Some states do not allow limitation on how long an implied warranty lasts, so this limitation may not apply to you.

For Commercial Applications, the liability of Firegear Outdoors is limited to the express terms of this warranty. We expressly disclaim any and all implied warranties, including any warranties of fitness for a particular purpose or merchantability.



We are not liable for any special, indirect or consequential damages. Our maximum liability is limited to the purchase price of the purchased units. Some states do not allow the exclusion or limitation of incidental or consequential damages, so this limitation or exclusion may not apply to you.

We do not authorize any person or company to assume for it any other obligation or liability in connection with the sale, installation, use, removal, return, or replacement of its equipment, and or such representation are binding.

Firegear Outdoors
17322 Gothard Street, Huntington Beach, CA 92647
www.firegearoutdoors.com
Phone: 800-966-8126
Email: order@firegearoutdoors.com



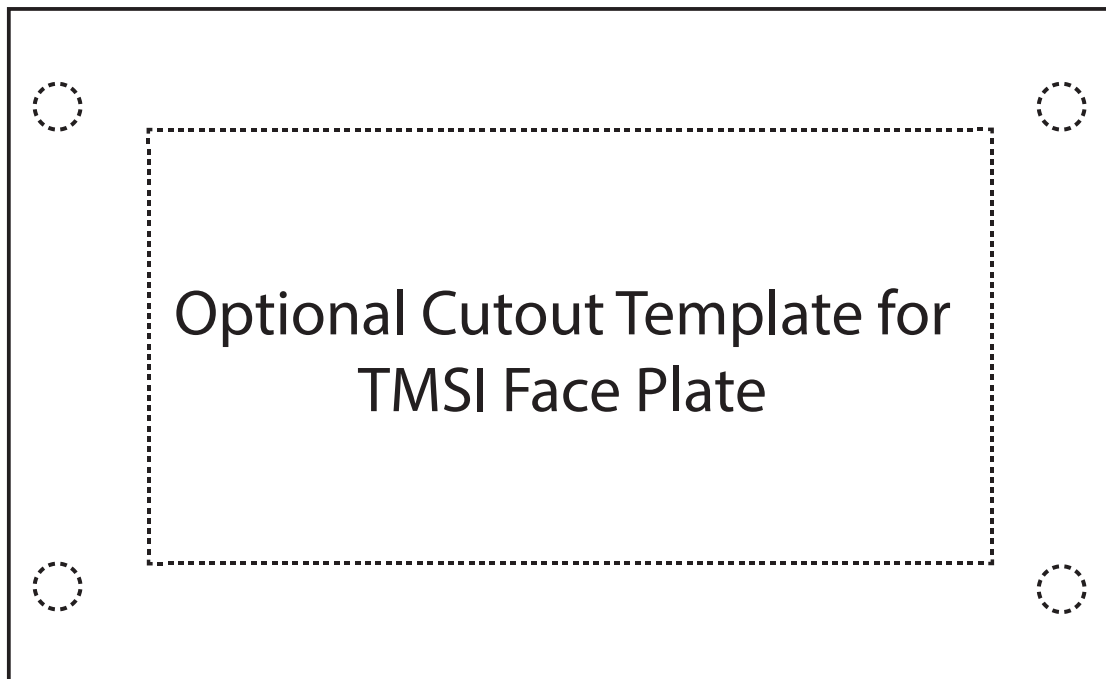

This fire pit instruction provides an option to mount the TMSI face plate to concrete board. Use the template above to complete the installation.

The TMSI face plate can be mounted vertically or horizontally. Our suggestion is to attach the face plate in a horizontal position with the gas valve on the left side. This allows the control knob text to be orientated in a position to be easily read. **Note:** Mounting plate can also be installed into a paver control panel (PAVER-CP-TMSI) bracket system.

Using scissors carefully cutout the template and trace it on your concrete board. The dotted line provides the cutout area to mount face plate. Use a concrete drill bit to drill (4) 3/16" diameter holes. Install the 1¼" screws through the front of the faceplate with the nuts and washers on the backside. These are all provided in the hardware bag.

CAUTION: Careful not to over-tighten screws and nuts to ensure the cement board does not crack or break.

The TMS valve bracket can be oriented in different positions to accommodate different installations. Once the bracket and knob are installed, the knob may not be oriented in a convenient position to easily read. If this is the case, we have provided a label that can be placed over top of the existing knob for the user to easily know which way to turn the control knob to light a fire pit.

The drawing below shows different positions bracket may be installed and which way to apply new label to better serve the user.

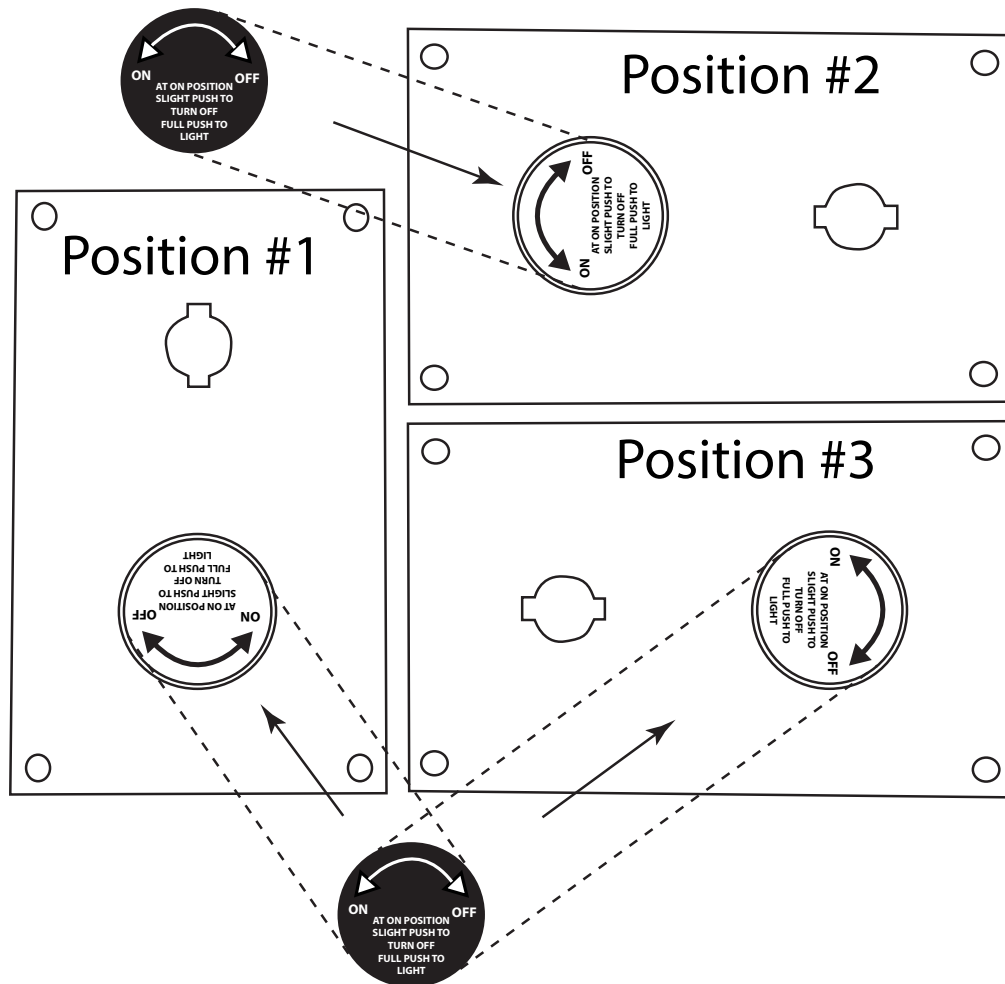



Having problems getting the fireplace to operate? Don't leave the job site! We want to help! Call 800.966.8126 for Technical Support between the hours of 8:00AM to 5:00PM PST.

BEFORE YOU CALL WE WILL NEED THIS INFORMATION

1. Model Number: _____
2. Serial Number: _____
3. How long is the gas line run? Nat Gas _____ LP Gas _____
4. What size is gas line? _____
5. Inlet Gas Pressure: _____ WC
Manifold Gas Pressure: _____ WC
6. What type of media are you using? _____
7. Review the troubleshooting section in the installation manual.
8. What are the symptoms? Please be prepared to explain.
9. Be prepared to send photos to us when on the phone.
10. Found missing or damaged parts? Let us know ASAP or send photos.