



## STANDARD FEATURES

- Available in a 40" see-through model
- Top flue 6" B-vent configuration
- Millivolt ignition provides continued operation in the event of a power outage
- Standard tempered glass and a protective screen\*
- Beautifully crafted ceramic fiber "oak" log set with heavy-duty grate
- Clean faced heat-circulating design
- Black painted interior (optional ceramic fiber liner available)
- Durable textured powder coat finish
- Optional outside air kit for increased performance
- Optional hand-held remote control available
- 20 Year Limited Warranty

\*All applicable models comply with ANSI Z21.50/88 barrier requirements.

## INTERIOR

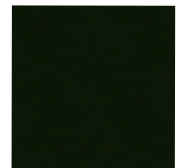

Black Painted (Standard)



Buff Stacked  
Ceramic Fiber Liner



Optional Touch Remote

## APPLIANCE SPECIFICATIONS

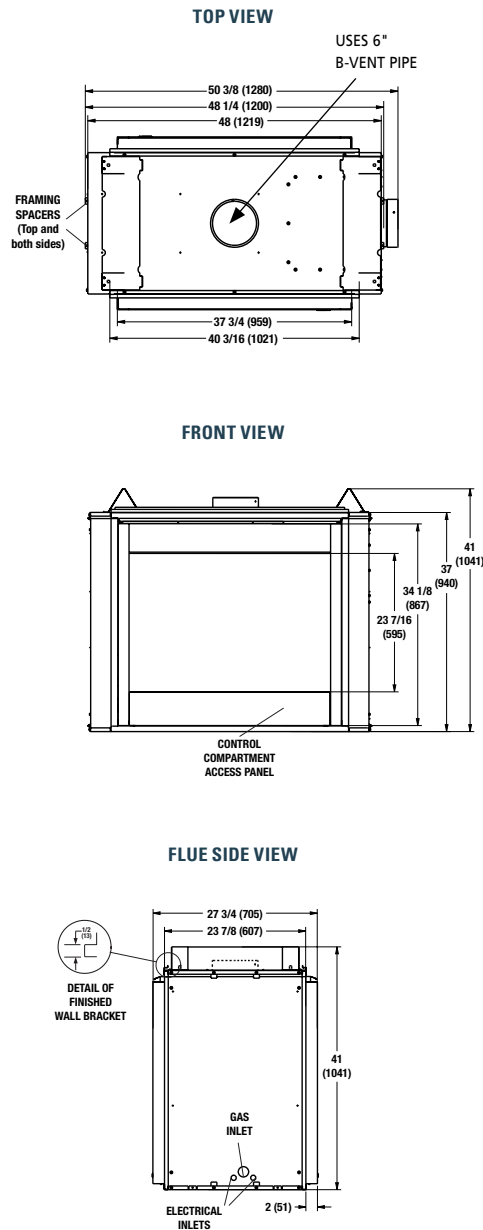

## FRAMING SPECIFICATIONS

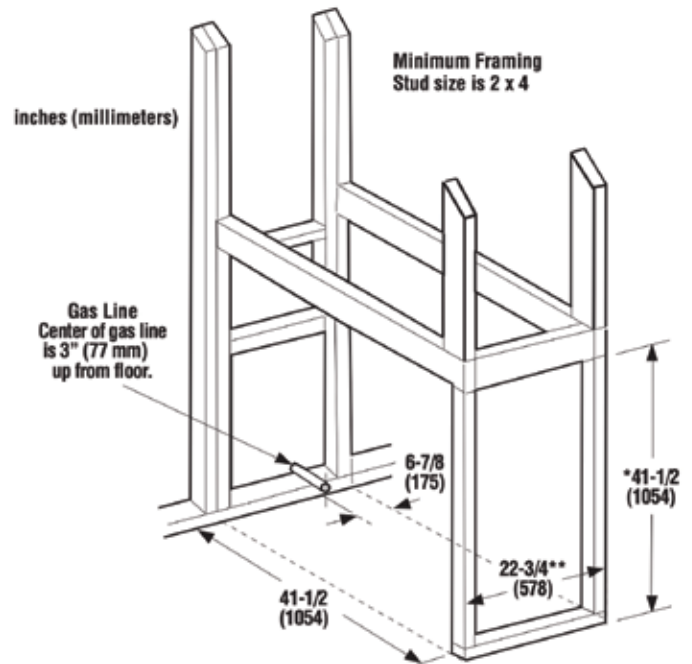

### BRT40 MULTI-VIEW FIREPLACE EFFICIENCIES — Listed to ANSI Z21.50 as a decorative gas appliance

MODEL	FUEL	BTU/HR
BRT40ST TMN	NG	30,000-37,500
BRT40ST TMP	LP	27,000-34,000

#### IMPORTANT NOTES:

As with any fireplace, this appliance is extremely hot during operation. Read and understand all operating instructions before using this appliance. For further information, consult your dealer.

Local conditions, such as elevation, wind, vent configuration and choice of fuel will affect overall appearance of the fire and heating performance. Performance can also vary with home design and insulation, climate, condition and type of fuel used, appliance location, burn rate, accessories chosen, chimney installation and how the appliance is operated.

Diagrams, illustrations and photographs are not to scale—consult installation instructions. Product designs, materials, dimensions, specifications, colors and prices are subject to change or discontinuance without notice.



© 2022 Innovative Hearth Products

785846M 08/22

Visit us online  
[SuperiorFireplaces.us.com](http://SuperiorFireplaces.us.com)

