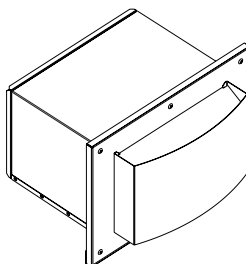
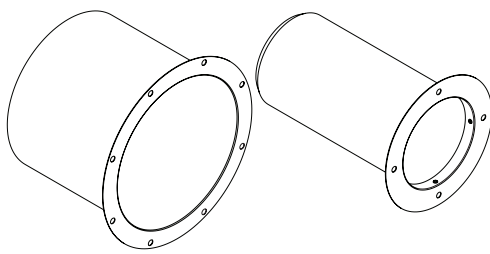
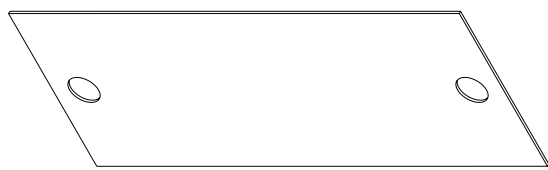
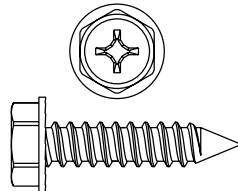
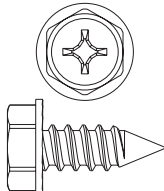

DVKPM-1 HORIZONTAL POWER-VENT INSTALLATION INSTRUCTIONS

**FOR USE ON THE FOLLOWING PRODUCTS EQUIPPED WITH MULTI FUNCTION REMOTE:
DVLL(27,48,60,72), DVCT(36,40), DVCX(36,42), TOP VENT ONLY**

INSTRUCTIONS MUST BE LEFT WITH THE OWNER FOR FUTURE REFERENCE AFTER INSTALLATION.

CARTON CONTENTS AND HARDWARE PACKET IDENTIFICATION		
Items Not Shown To Scale 		
Vertical Conversion Kit Sheet Metal - QTY (1)	Dura-Vent Pipe Adaptor - QTY (1)	
		
Flue Restrictor - QTY (1)	#10 X 1" Hex Head Screws - QTY (8)	#10 X 1/2" Hex Head Screws - QTY (12)

TOOLS NEEDED:

- 5/16 inch nut driver or screw gun
- #2 Phillips driver or screw gun
- 300° F continious exposure silicone sealant

⚠ CAUTION
Sharp edges. Use gloves when installing this kit.

ACCESSORIES		
Description	Model Number	Used With
DVKCV	Vertical Conversion Kit- Power Vent	DVKPM
WHP25	25 Foot Wire Harness Kit	DVKPM
WHP50	50 Foot Wire Harness Kit	DVKPM
WHP75	75 Foot Wire Harness Kit	DVKPM
WHP100	100 Foot Wire Harness Kit	DVKPM
SD58DVAX46	Decreaser 5X8 to 4X6-5/8	DVCT, DVLL, DVCX
These Parts Are Required For DVKPM Installation On Units With Serial Number Before 1821xxxxxx		
24339	Backer Plate -Junction	DVCT, DVCX, DVLL27
37094	Access Panel	DVLL(48,72)
37761	Access Panel	DVLL48SP
34395	Access Panel	DVLL60

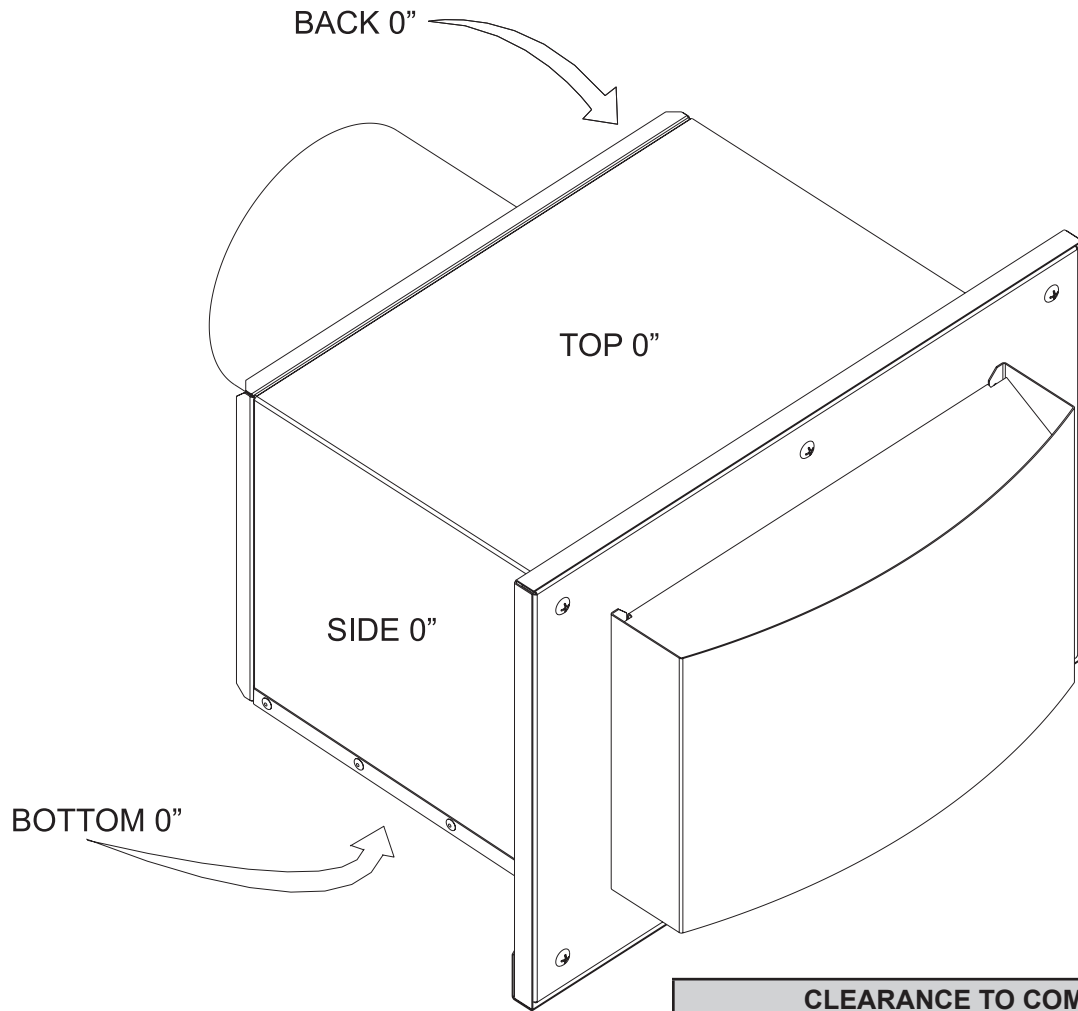

CLEARANCE TO COMBUSTIBLES
Back 0 inch
Sides 0 inch
Top/Bottom 0 inch

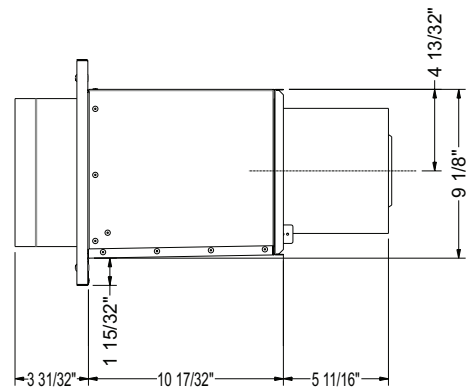
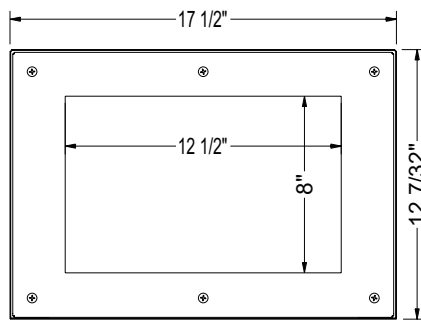
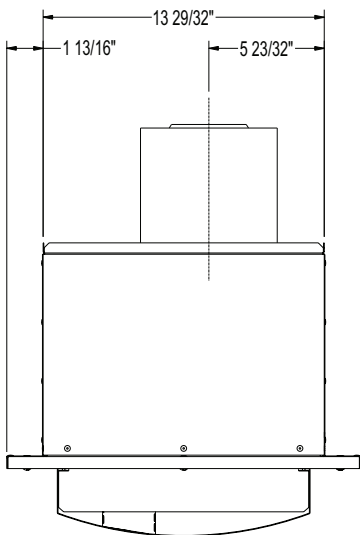

POWER-VENT WIRING DIAGRAM

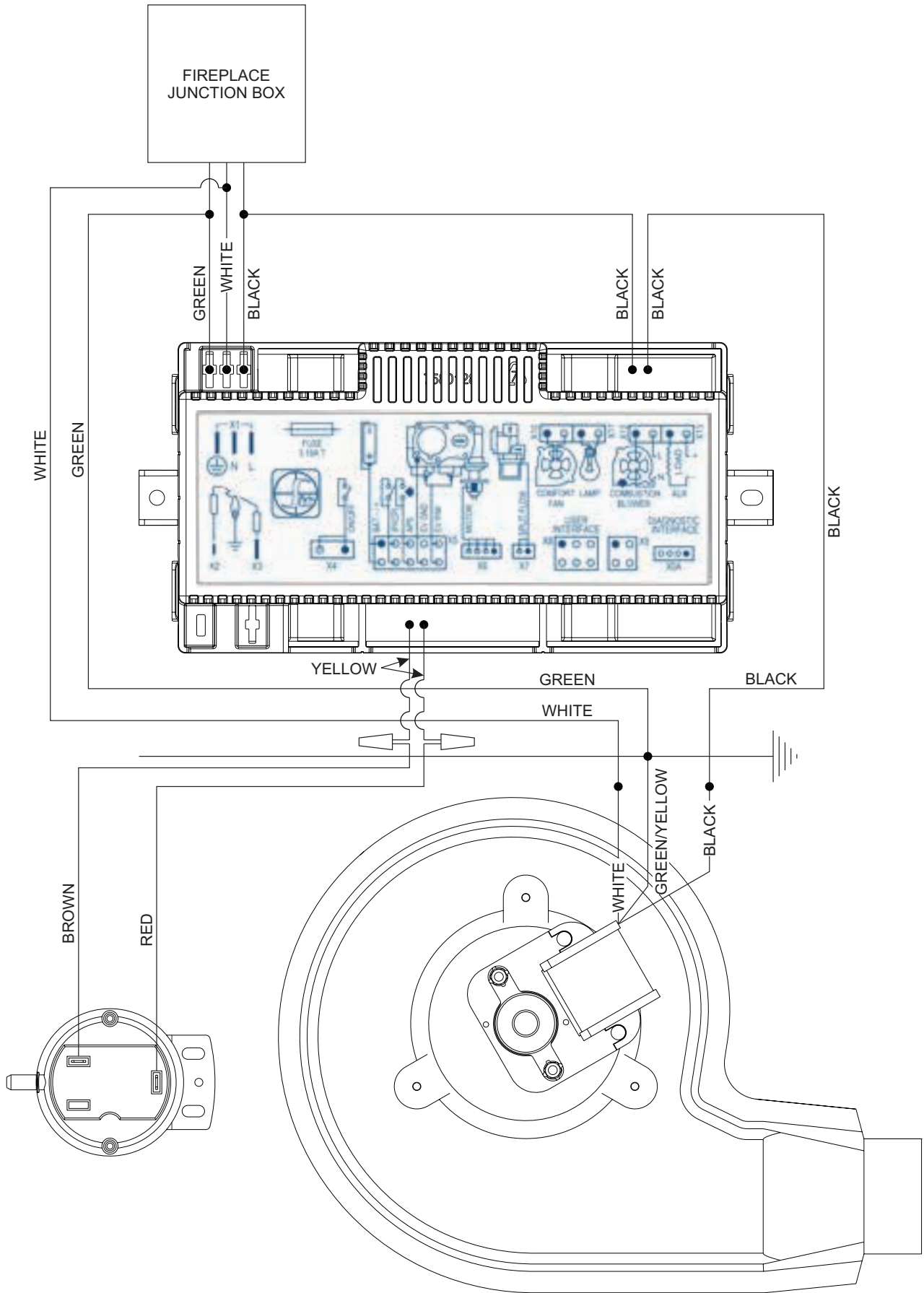

Figure 1

For vent runs in the gray section of the blender door setting chart, a restrictor must be added to the flue connector of the power vent.

1. Attach the flue restrictor under the smaller pipe from the Dura-Vent adaptor with the 4 #10 X 1/2 inch screws. If the vent run is in the white section of the blender door setting chart, attach the smaller pipe from the Dura-Vent adaptor without the restrictor using 4 #10 x 1/2 inch screws as shown in **Figure 2**.

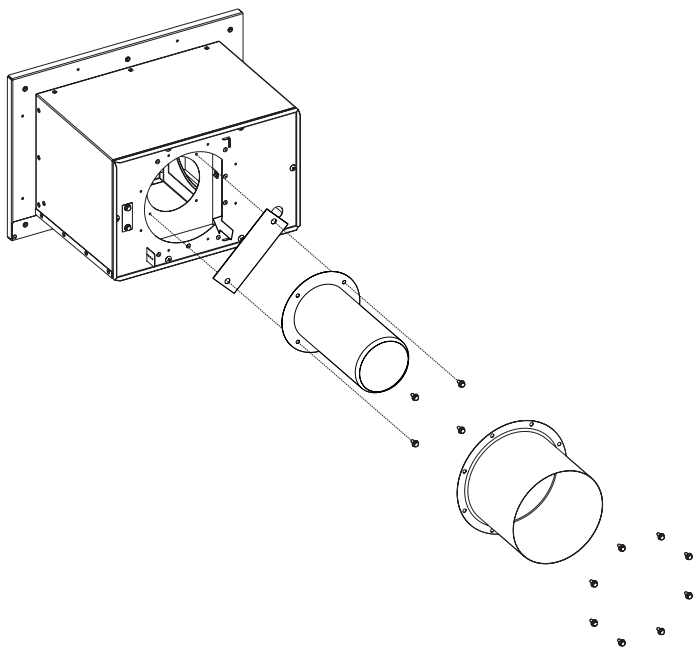

Figure 2

2. Use the remaining 8 #10X1/2 inch screws to attach the larger DuraVent adapter pipe.

ELECTRICAL CONNECTIONS ON FIREPLACE

⚠ CAUTION

All wiring should be done by a qualified electrician and shall be in compliance with all local, city and state building codes. Before making the electrical connection, make sure that the main power supply is disconnected. The fireplace, when installed, must be electrically grounded in accordance with local codes, or in the absence of local codes, with the National Electrical Code ANSI/NFPA 70 (Latest Edition).

FOR DVCT(36,40), DVCX(36,42), DVLL(27)

Locate the factory installed electrical junction box located on the right side of the fireplace shown in **Figure 3**. (If the fireplace serial number is before 1821XXXXXX you will need to purchase 24339 backer plate-junction box to replace the current backer plate). Remove the knockout from the rear side of the junction box, insert the 90 degree side of the power vent harness through the hole and secure with nut. Remove a side knockout and insert the bushing supplied with the Power-Vent wire harness. Thread the harness through the bushing and into the cabinet of the fireplace.

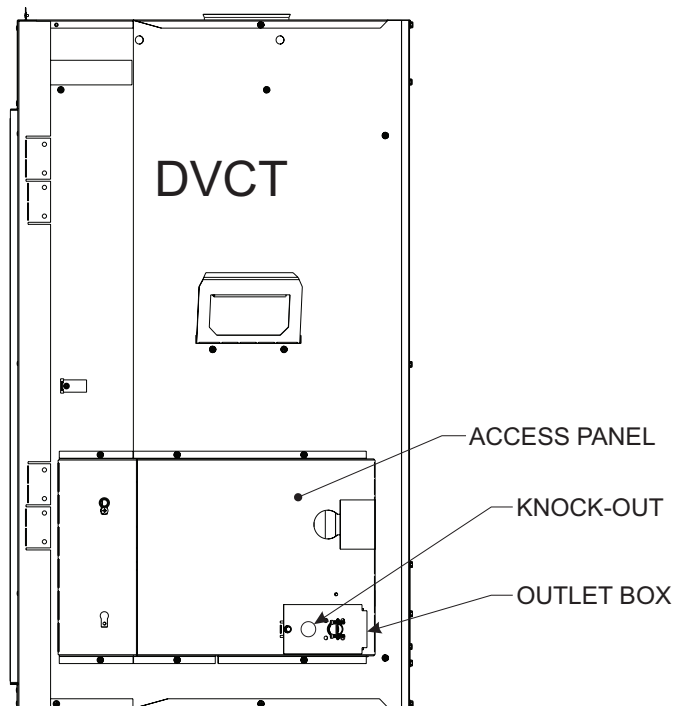

Figure 3

FOR DVLL(48,48SP,60,72)

Locate and remove the access panel on the right side of the fireplace.(If the fireplace serial number is before 1821XXXXXX you will need to purchase 34395 for DVLL60, 37761 for DVLL48SP and 37094 for DVLL(48,72) to replace the existing panel.) Remove the knockout from the access panel and insert the 90 degree side of the power vent harness through the hole and secure with nut.

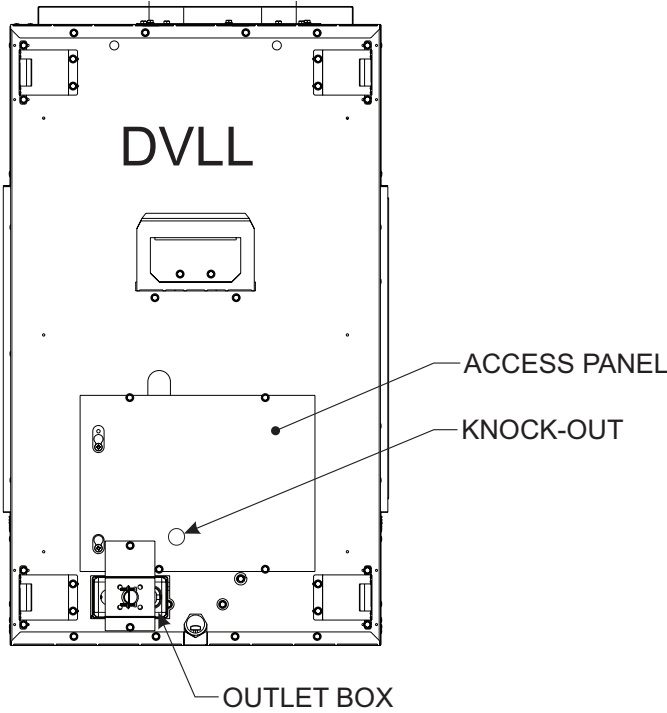

Figure 4

Locate the receiver module on the right side of the fireplace. Document or label the factory wiring connections to the receiver module for future reference then remove all connections to the module. Remove the module from the fireplace and remove the top cover of the module by releasing the 4 clips at the sides of the module. With the cover removed locate and remove the jumper on the JP1 Terminal as shown in **Figure 5**.

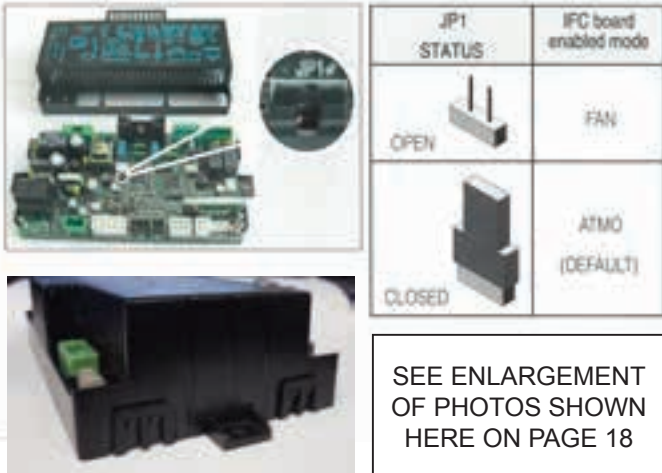

Figure 5

Replace the cover and reconnect X2, X3, X4 and X6 harnesses (X7, X10 and X11 if available). X1 wiring will be connected later.

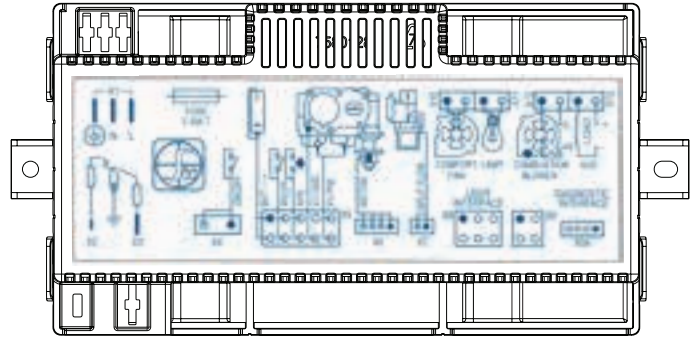

Figure 6

NOTE: The user interface(X8) and battery backup(X5) must be removed before the Power-Vent can be operated.

NOTE: Continuous pilot mode will not be available once Power-Vent is installed.

Connect the female disconnect of the green wire on the main wire harness to the ground post of the X1 terminal and connect the female terminal of the white wire to the "N" post of the X1 terminal on the receiver module. Connect the female disconnect of the jumper harness to the "L" post of the X1 terminal on the receiver module. Connect the green male disconnect to the ground wire, the white male disconnect to the neutral wire, and the black male disconnect to the hot wire coming from the junction box.

Connect the terminal block to the X12 terminal. Insert the black pin of the jumper harness and the black pin of the main harness into the adapter on the X12 terminal. Tighten the set screw until the pins are snug.

Locate and cut the Yellow wire with the APS tag on the X5 connector, strip insulation 1/2 inch on both wires and use wire nuts to connect the Red and Brown wires from the Power-Vent harness.

ELECTRICAL CONNECTIONS ON POWER VENT

Remove the rear panel and flue box of the Power-Vent by removing the six #10-24 X 3/8 inch screws shown in **Figure 7**.

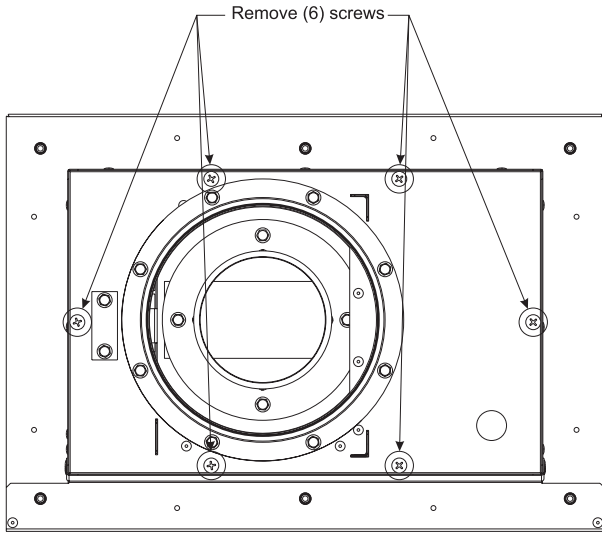

Figure 7

Insert the straight side of the main harness through the 7/8 inch hole in the rear panel of the Power-Vent and secure with nut. Connect the black and white wire to the terminals on the inducer motor and connect the red and brown wires to the vacuum switch as shown in **Figure 8**.

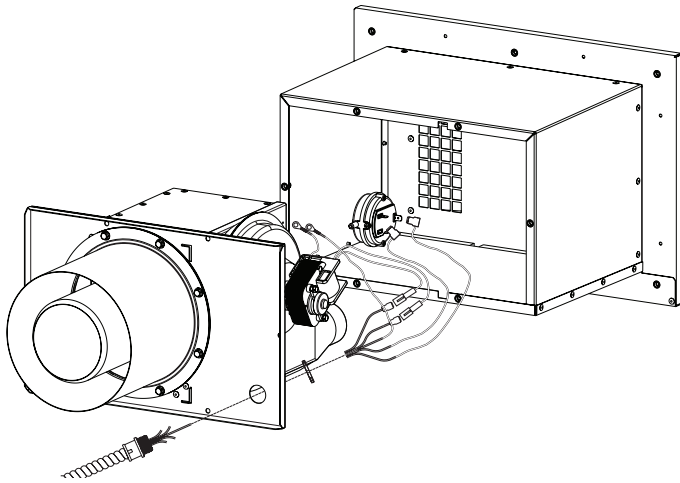

Figure 8

Remove the top #10 X 1/2 inch screw on the front of the flue box and attach the green wire from the main harness and the green/yellow wire from the inducer motor with the screw as shown in **Figure 9**.

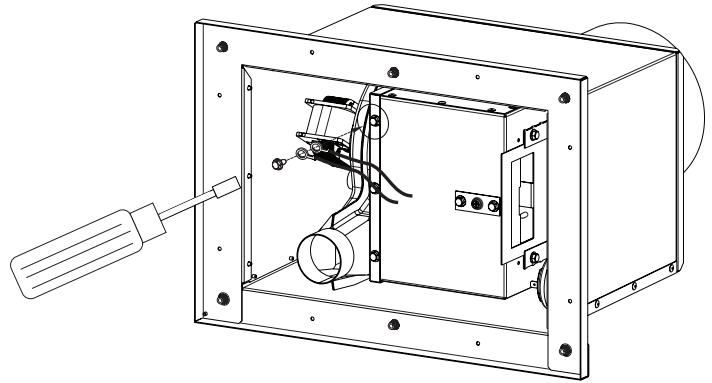

Figure 9

Re-attach the rear panel and flue box to the Power-Vent outer box with six #10 X 3/8 inch screws.

VENT INFORMATION

Begin the vent system installation by identifying the path the vent will take from the fireplace to the power-vent. Verify clearances are met throughout the entire path of the venting system.

Determine how the vent system will be terminated, (vertically or horizontally). Verify clearances for the termination.

NOTICE: If terminated vertically, DVKCV (Vertical Conversion Kit) is required.

NOTICE: This Power-Vent cannot be vented out the rear of the fireplace.

NOTICE: This Power-Vent can only be used with DuraVent Direct Vent Pro® 4 X 6-5/8 inch piping. If your fireplace is equipped with 5 X 8 inch connections you will need to use the SD58DVAX46 Decreaser.

NOTICE: All outer connection joints must be sealed with aluminum tape or silicone sealant rated above 300°F/149°C. The inner flue joints do not require any sealant.

THIS POWER VENT CAN BE ROUTED IN ANY PATH AS LONG AS IT MEETS THE FOLLOWING REQUIREMENTS:

- Maximum vertical distance above Fireplace floor=60 ft
- Maximum effective length = 110 ft (effective length calculations shown below in **Equation 1**).
- Minimum effective length = 15 ft
 - DVCT units must have the fireplace damper door fully open for any run less than 25 ft.
- Maximum 6-90° elbows or 12-45° elbows
- Maximum 5 ft below the base of the fireplace
- Maximum drop of 12 ft from highest point in run.
- If vent pipe runs downward it cannot turn back upward.

EFFECTIVE LENGTH IS CALCULATED BY THE FOLLOWING EQUATION:

Equation 1

Effective length=Vertical Run Up + (2 × Vertical Run Down) + Horizontal Run + (3 × # of 90° elbows) +(1.5 × # of 45° elbows)

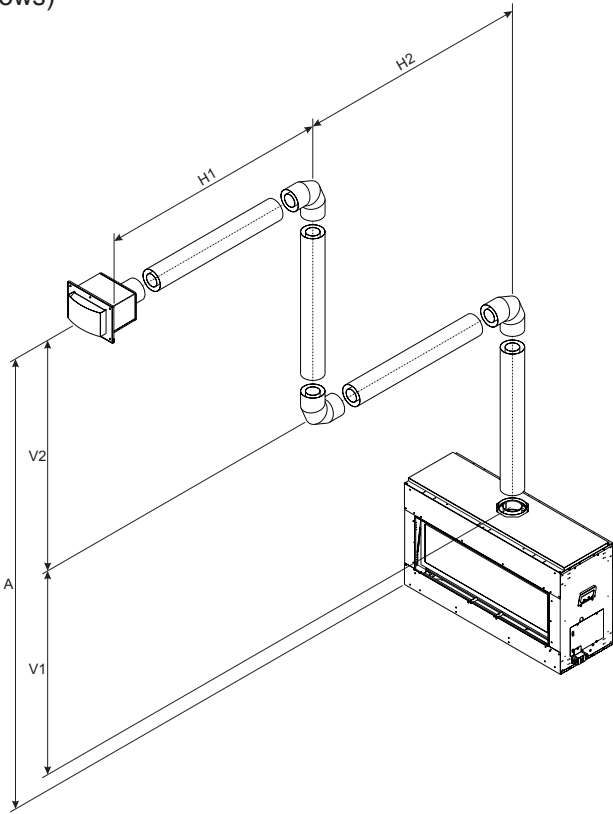

Figure 10

EXAMPLE 1						
Fireplace Height	V1	V2	H1	H2	Elbows	Total Effective Length
4 ft	5 ft	10 ft	5 ft	10 ft	3	43 ft

Vertical Run Up = (Fireplace Height + V1 + V2) = 4 ft. + 5 ft. + 10 ft. = 19 ft.

Vertical Run Down = 0 ft.

Horizontal Run = (H1 + H2) = (5 ft. + 10 ft.) = 15 ft.

Number of Elbows = 3

Effective Length = Vertical Run Up + (2 x Vertical Run Down) + Horizontal Run + (3 x # of 90° Elbows) + (1.5 x # of 45° Elbows)

Effective Length = 19 ft. + (2 x 0 ft.) + 15 ft. + (3 x 3 Elbows) + (1.5 x 0 Elbows)

Effective Length = 43 ft.

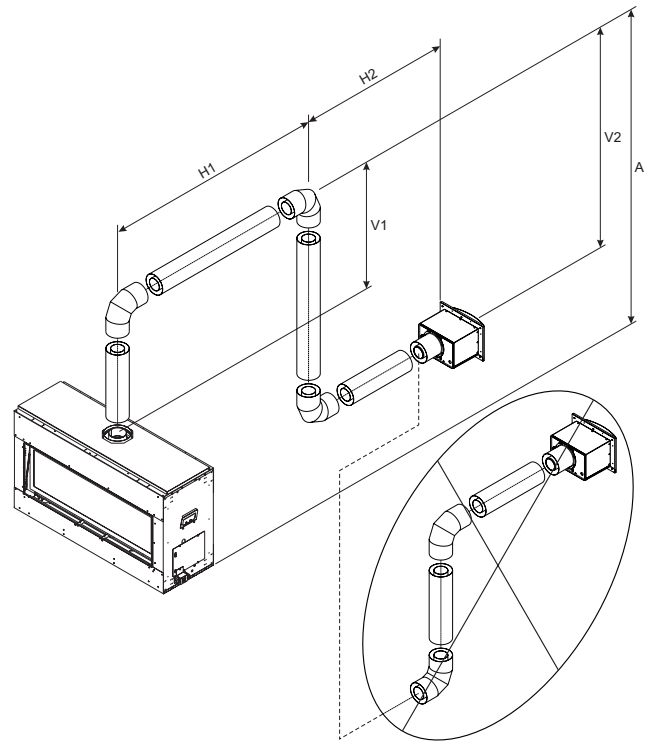

Figure 11

EXAMPLE 2						
Fireplace Height	V1	V2	H1	H2	Elbows	Total Effective Length
4 ft	5 ft	10 ft	10 ft	5 ft	3	53 ft

Vertical Run Up = (Fireplace Height + V1) = (4 ft. + 5 ft.) = 9 ft.

Vertical Run Down = 10 ft.

Horizontal Run = (H1 + H2) = (5 ft. + 10 ft.) = 15 ft.

Number of Elbows = 3

Effective Length = Vertical Run Up + (2 x Vertical Run Down) + Horizontal Run + (3 x # of 90° Elbows) + (1.5 x # of 45° Elbows)

Effective Length = 9 ft. + (2 x 10 ft.) + 15 ft. + (3 x 3 Elbows) + (1.5 x 0 Elbows)

Effective Length = 53 ft.

NOTICE: Once vent runs in downward direction it cannot turn back upward.

NOTICE: If this Power-Vent will be serviced from the rear side a minimum of 12 inches of vent pipe must be removable to gain clearance for removal of the rear panel. This can be achieved with an adjustable pipe that will collapse to clear the Power-Vent connector flange and then be removed. This can also be achieved by breaking the connection at the nearest elbow and removing that section of pipe.

Ensure the sidewall venting clearances are observed. If venting system is installed below ground, we recommend a window well with adequate and proper drainage to be installed around the termination area.

TYPICAL BASEMENT INSTALLATION

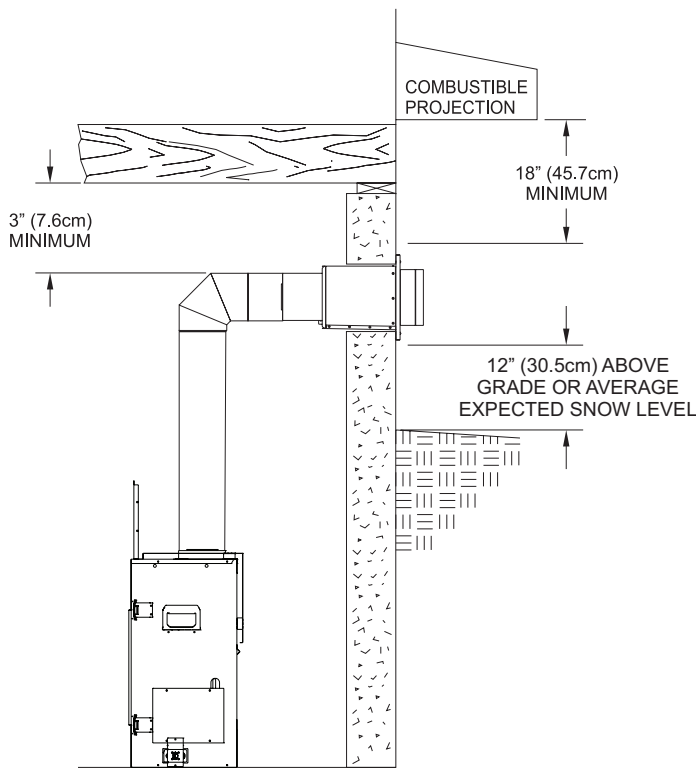

Figure 12

NOTE: Maintain at least 1/4 inch rise for every 12 inches of vent run.

INSTALLING SUPPORT BRACKETS

A horizontal pipe support **MUST BE** used for each 3 feet of horizontal run. The pipe supports should be placed around the pipe and nailed in place to framing members. There **MUST BE** a 3 inch clearance to combustibles above 6-5/8 inch diameter pipe and elbows and 1 inch clearance on both sides and bottom of 6-5/8 inch pipe to combustibles on all horizontal pipe sections and elbows.

Vertical runs of this vent systems must be supported every 4 feet above the appliance flue outlet by wall brackets attached to the 6-5/8 inch vent pipe and secured with nails or screws to structural framing members.

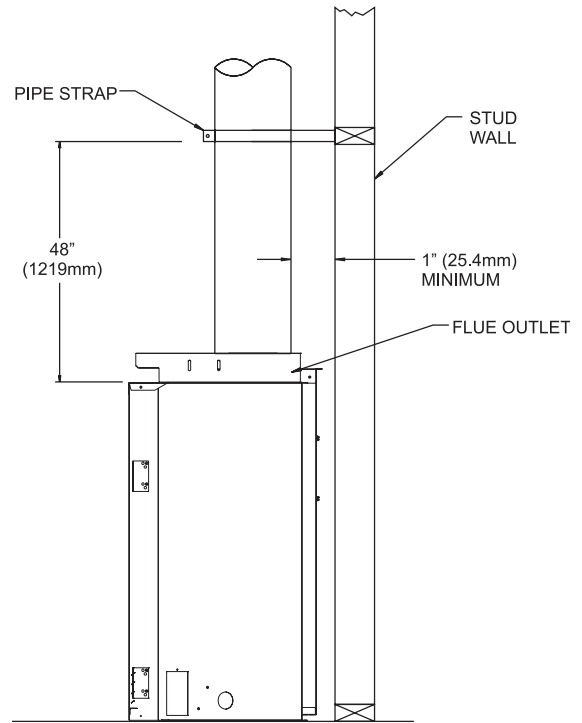

Figure 13

INSTALLING FIRESTOPS

Firestops are required for safety whenever the vent system passes through an interior wall, an exterior wall, or a ceiling. These firestops act as a firebreak heat shield and as a means to insure that minimum clearances are maintained to the vent system.

Horizontal runs in the vent system which pass through either interior or exterior walls, require the use of wall firestops on both sides of the wall through which the vent passes.

Position the firestops on both sides of the 10 x 11 inch hole, previously cut. Secure with nails or screws. The heat shields of the firestops **MUST BE** placed towards the top of the hole. Continue the vent run through the firestops. **See Figure 14.**

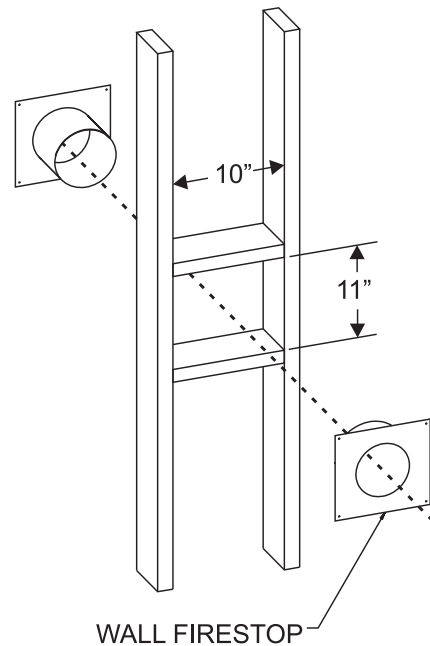

Figure 14

Vertical runs of this system which pass through ceilings require the use of one ceiling firestop at the hole in each ceiling through which the vent passes.

Position a plumb bob directly over the center of the vertical vent component and mark the ceiling to establish the center point of the vent. Drill a hole or drive a nail through this center point and check the floor above for any obstructions such as wiring or plumbing runs. Reposition the appliance and vent system, if necessary, to accommodate ceiling joists and/or obstructions.

Cut a 10 inch x 10 inch hole through the ceiling, using the center point previously marked. Frame the hole with framing lumber the same size as the ceiling joists. **See Figure 15.** If the area above the ceiling is NOT an attic, position and secure the ceiling firestop on the ceiling side of the previously cut and framed hole. **See Figure 16.** If the area above the ceiling is an attic, position and secure the firestop on top of the previously framed hole. **See Figure 17.**

NOTE: Remove insulation from the framed area in the attic before installing the firestop and/or vent pipes.

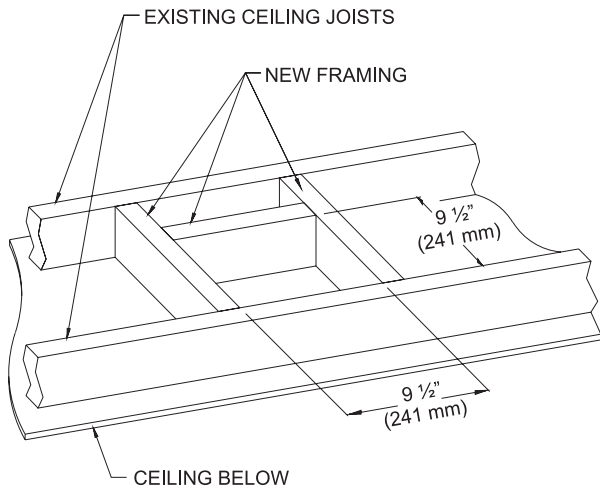

Figure 15

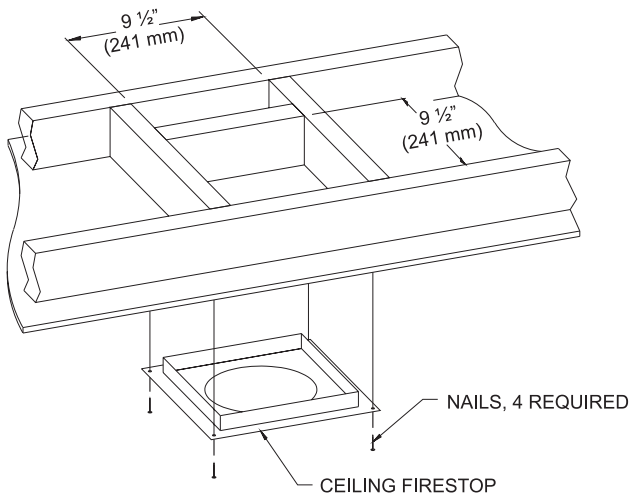

Figure 16

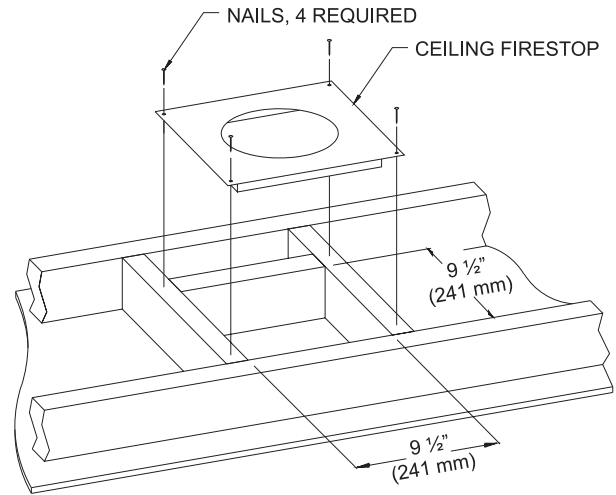

Figure 17

VENT PIPE CLEARANCE

NOTICE: Maintain one inch of clearance around vertical vent pipe. **See Figure 18.**

For horizontal vent, maintain a minimum 1 inch clearance to the bottom and sides of the vent, and 3 inch clearance to combustibles above the vent pipe. **See Figure 19.**

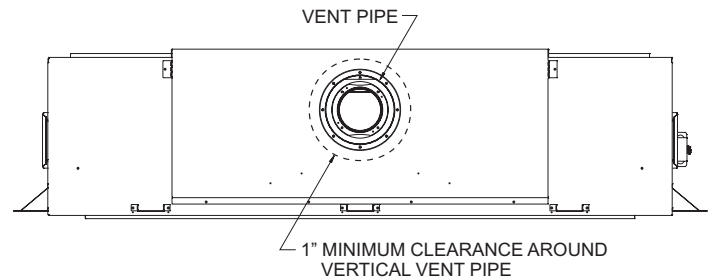

Figure 18

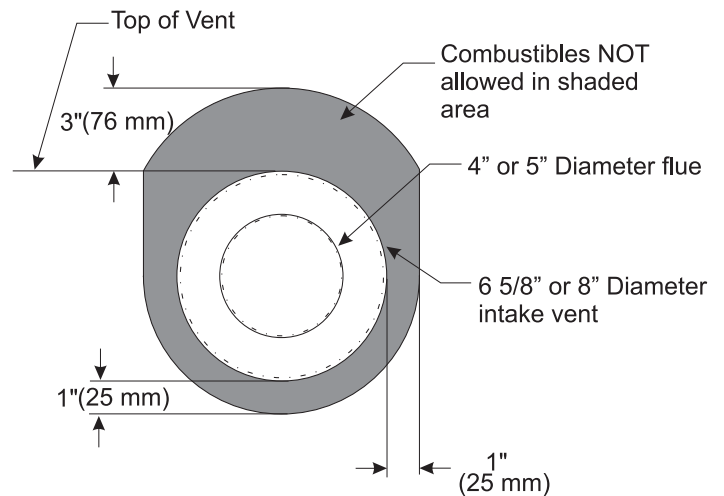

Figure 19

TERMINATION CLEARANCE FOR BUILDINGS WITH COMBUSTIBLE AND NONCOMBUSTIBLE EXTERIORS.

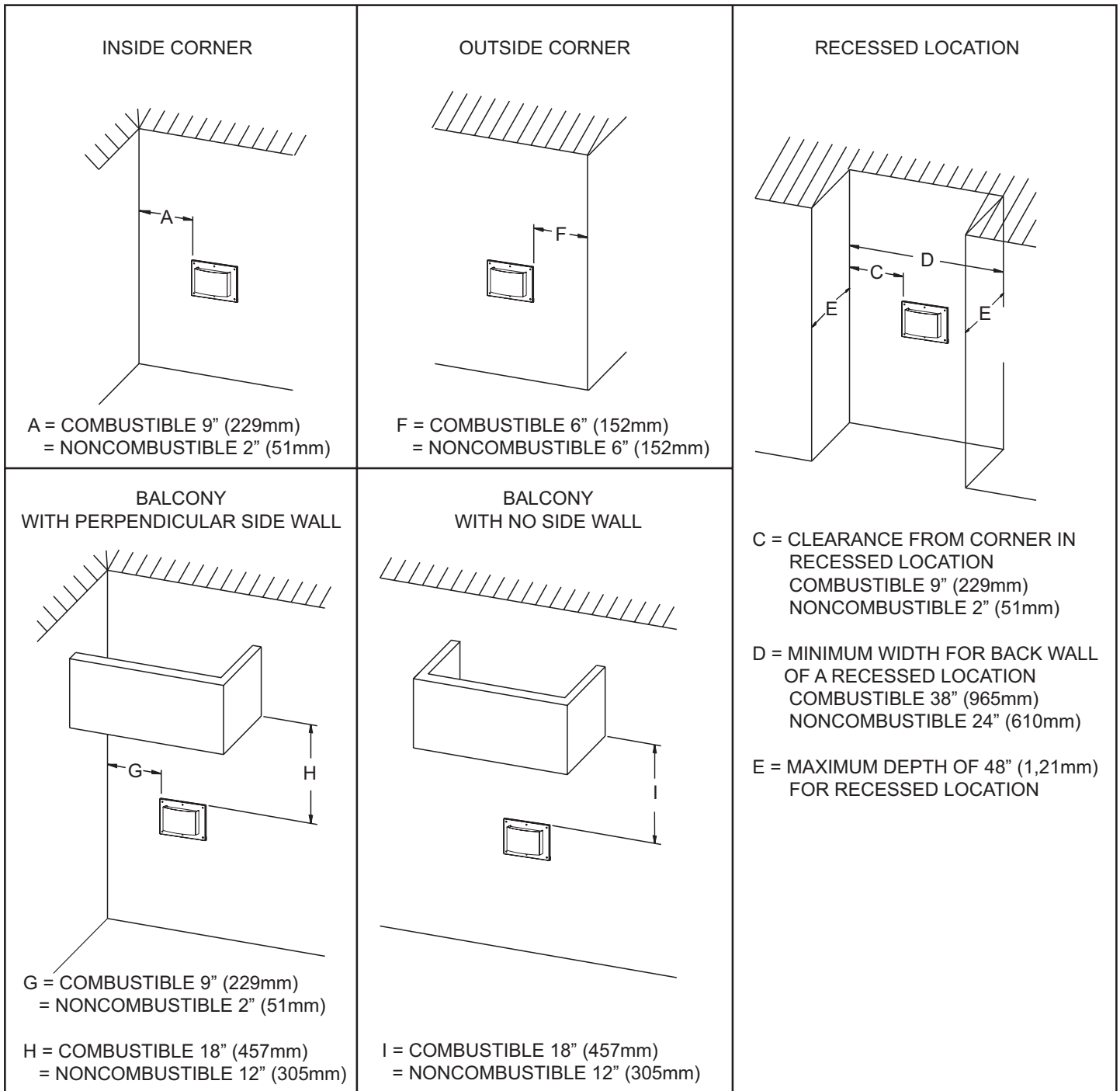
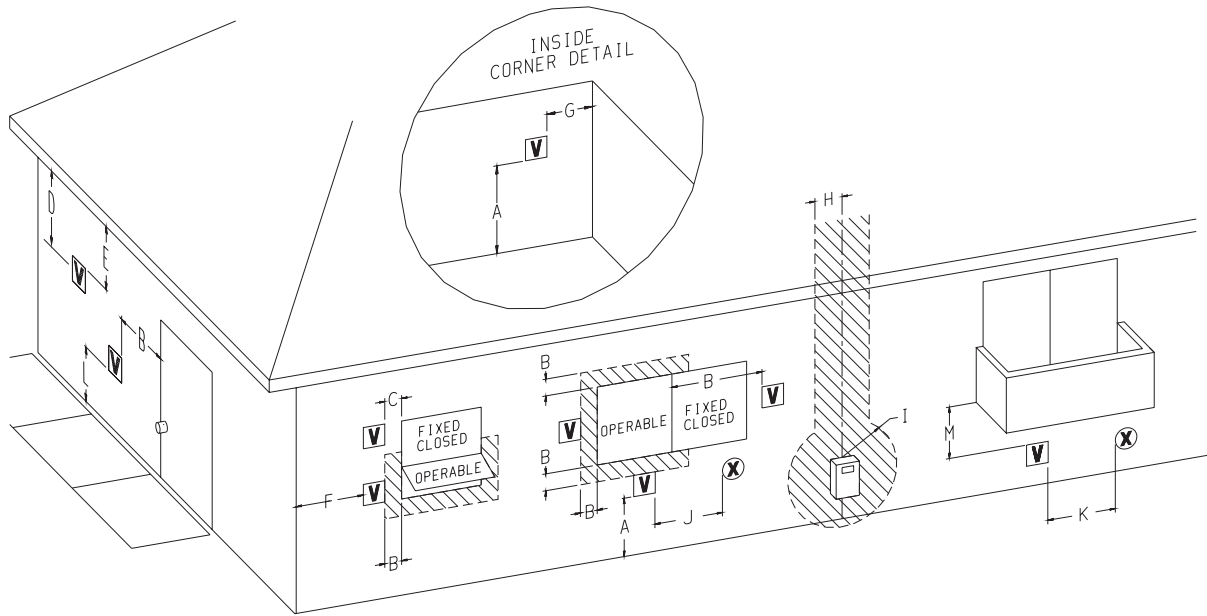

Figure 20

VENT TERMINATION CLEARNCES



V VENT TERMINAL

X AIR SUPPLY INLET

AREA WHERE TERMINAL IS NOT PERMITTED

	Canadian Installations ¹	US Installations ²		Canadian Installations ¹	US Installations ²
A= Clearance above grade, veranda, porch, deck, or balcony	12 in (30 cm)	12 in (30cm)	I= Clearance to service regulator vent outlet	3 ft (91 cm)	6 ft
B= Clearance to window or door that may be open	6 in (15 cm) for appliances ≤ 10,000 Btuh (3 kW), 12 in (30 cm) for appliances > 10,000 Btuh (3 kW) and ≤ 100,000 Btuh (30 kW), 36 in (91 cm) for appliances > 100,000 Btuh (30 kW)	6 in (15 cm) for appliances ≤ 10,000 Btuh (3 kW), 9 in (23 cm) for appliances > 10,000 Btuh (3 kW) and ≤ 50,000 Btuh (15 kW), 12 in (30 cm) for appliances > 50,000 Btuh (15 kW)	J= Clearance to nonmechanical air supply inlet to building or the combustion air inlet to any other appliance	6 in (15 cm) for appliances ≤ 10,000 Btuh (3 kW), 12 in (30 cm) for appliances > 10,000 Btuh (3 kW) and ≤ 100,000 Btuh (30 kW), 36 in (91 cm) for appliances > 100,000 Btuh (30 kW)	6 in (15 cm) for appliances ≤ 10,000 Btuh (3 kW), 9 in (23 cm) for appliances > 10,000 Btuh (3 kW) and ≤ 50,000 Btuh (15 kW), 12 in (30 cm) for appliances > 50,000 Btuh (15 kW)
C= Clearance to permanently closed window	12 in (30 cm)	12 in (30 cm)	K= Clearance to a mechanical air supply inlet	6 ft (1.83 m)	3 ft (91 cm) above if within 10 ft (3 m) horizontally
D= Vertical clearance ventilated soffit located above the terminal within a horizontal distance of 2 feet (61 cm) from the center line of the terminal	24 in (61 cm)	24 in (61 cm)	L= Clearance above paved sidewalk or paved driveway located on public property	7 ft (2.13 m) †	7 ft (2.13 m) †
E= Clearance to unventilated soffit	12 in (30 cm)	12 in (30 cm)	M= Clearance under veranda, porch deck, or balcony	12 in (30 cm) ‡	12 in (30 cm) ‡
F= Clearance to outside corner	6 in (15 cm)	6 in (15 cm)	1	In accordance with the current CSA B149.1, Natural Gas and Propane Installation Code	
G= Clearance inside corner	9 in (23 cm)	9 in (23 cm)	2	In Accordance with the current ANSI Z223.1/NFPA 54, National Fuel Gas Code	
H= Clearance to each side of center line extended above meter/regulator assembly	3 ft (91 cm) within a height 15 ft (4.5 m) above the meter/regulator assembly	3 ft (91 cm)	†	A vent shall not terminate directly above a sidewalk or paved driveway that is located between two single family dwellings and serves both dwellings	
ATTENTION: Vinyl Soffit, Vinyl Ceiling, Vinyl Overhang Disclaimer Clearances are to heat resistant material (i.e. wood, metal). This does not include vinyl. Empire Comfort Systems Inc. will not be held responsible for heat damage caused from terminating under vinyl overhangs, vinyl ceilings or vinyl ventilated/unventilated soffits.			‡	Permitted only if veranda, porch, deck, or balcony is fully open on a minimum of two sides beneath the floor.	
			*	For clearances not specified in ANSI Z223.1/NFPA 54 or CSA B149.1, one of the following shall be indicated: Clearance in accordance with local installation codes and the requirements of the gas supplier.	

INSTALLATION

Framing

1. Once termination location has been determined build a frame with material that has the same dimensions as the current wall. As shown in **Figure 21**. The box must be 9-1/2 inches tall by 14-1/2 inches wide.

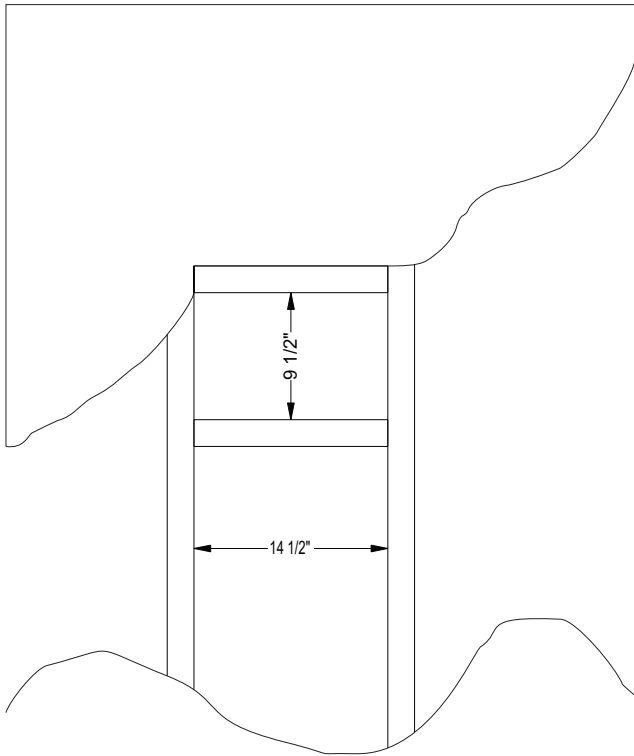

Figure 21

2. Cut a 9-1/2 inches tall by 14-1/2 inches wide hole into the wall, be sure to stay inside the new framing.
3. Remove the front fascia by removing the 6 #10-24 X 3/8 inch screws shown in **Figures 22 and 23**. Set front fascia and foam gasket aside.

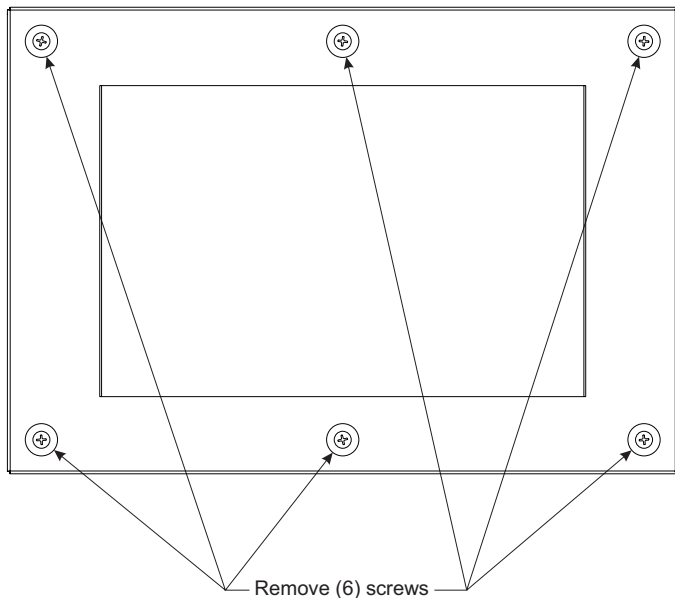

Figure 22

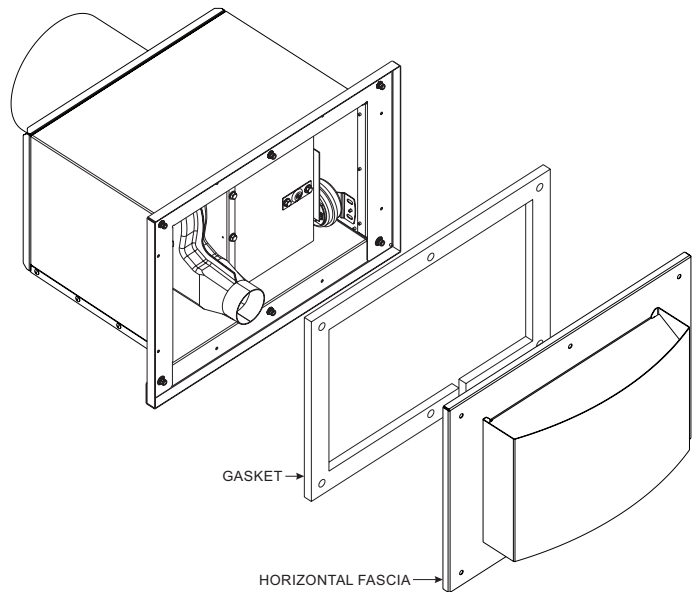

Figure 23

4. Set the Power-Vent on its face and apply a bead of silicone sealant to the rear surface of the flange to create a weather tight seal between the mounting flange and the wall.

NOTE: Sealant must be rated for 300° F continuous exposure at minimum.

5. Place the Power-vent into the hole with the inducer outlet toward the bottom and secure with 8 #10X 1 inch screws as shown in **Figure 24**.

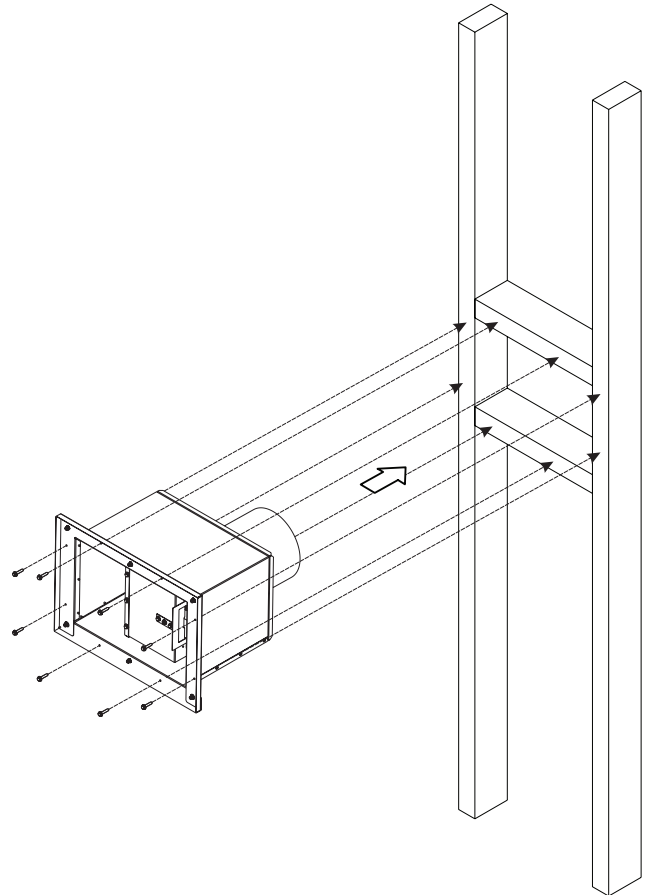

Figure 24

- Apply a bead of silicone sealant to create a watertight seal between finishing material and the Power-Vent flange.

NOTE: Sealant must be rated for 300° F continuous exposure at minimum.

- Reinstall foam gasket with the cutout on the bottom and front fascia with 6 #10-24 X 3/8 inch screws.

BLENDER ADJUSTMENT

Removable flue restrictors like shown in **Figure 25** supplied with the fireplace, cannot be used when this Power-Vent is used.

NOTE: Permanent flue dampers (used on DVCT models) must be fully open for any run less than 25 feet. For any run greater than 25 feet, set the damper to the units recommended setting. (Refer to DVCT manual instructions).

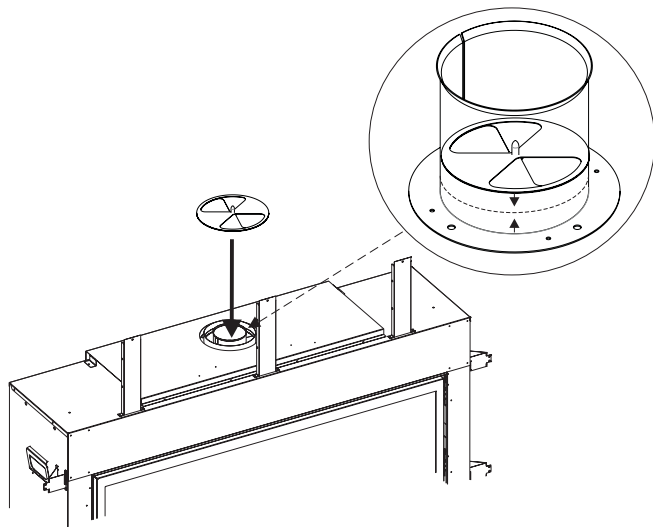

Figure 25

ADJUSTMENT OF BLENDER PLATE FROM THE FRONT

If adjusting the blender from the front side, turning the blender adjustment bolt clockwise will close the blender door. Turning the blender door adjustment bolt counter clockwise will open the blender door. The blender door opening can be checked by measuring the gap shown in **Figure 26**.

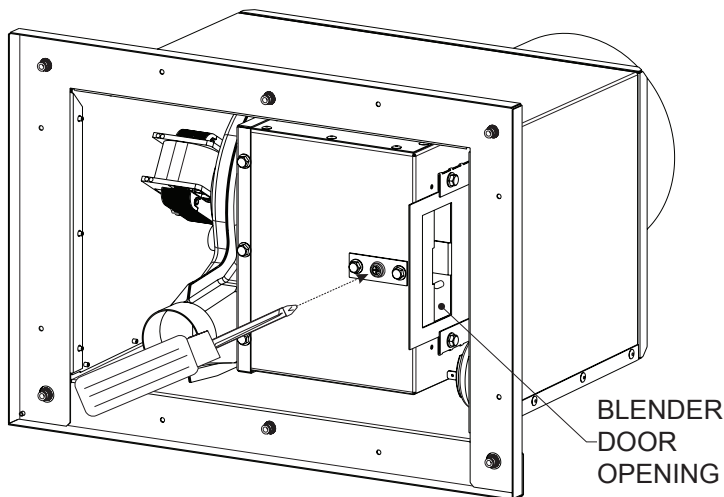
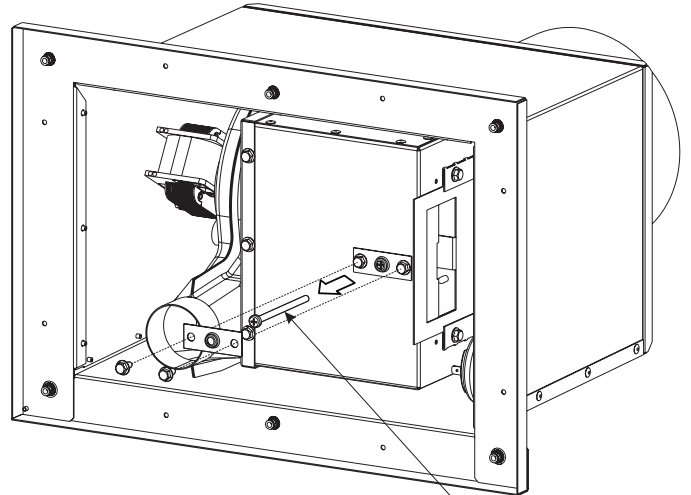

Figure 26

This power vent comes from the factory to be adjusted from the front side, to adjust the blender from the rear it must be converted to rear blender adjustment.

CONVERSIONS TO REAR ADJUSTMENT:

- Remove the 2 #10 X 1/2 inch screws holding the bolt retainer onto the flue box, then remove the blender adjustment bolt as shown in **Figure 27**.



BLENDER ADJUSTMENT BOLT

Figure 27

- Remove the cover from the rear side of the unit by removing the 2 #10 X 1/2 inch screws shown in **Figure 28**.

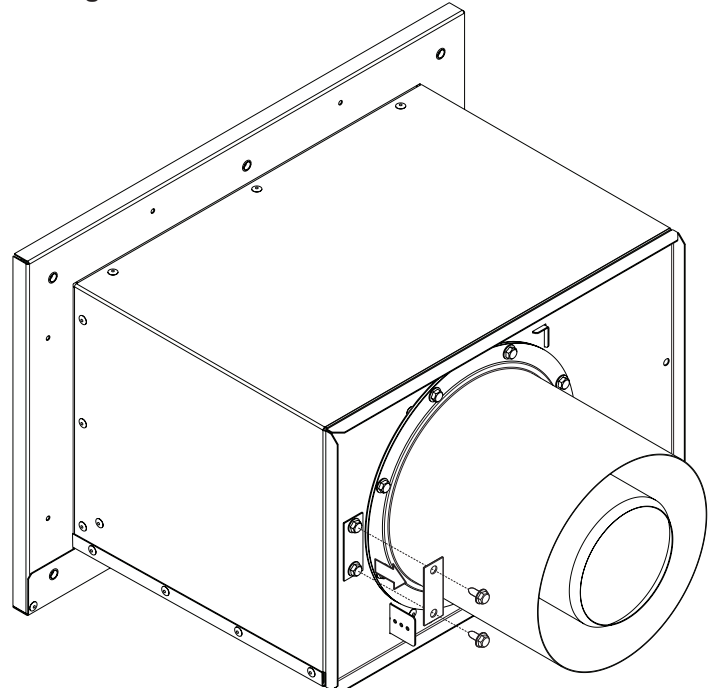

Figure 28

3. Attach the cover to the flue box where the bolt retainer was removed as shown in **Figure 29**.

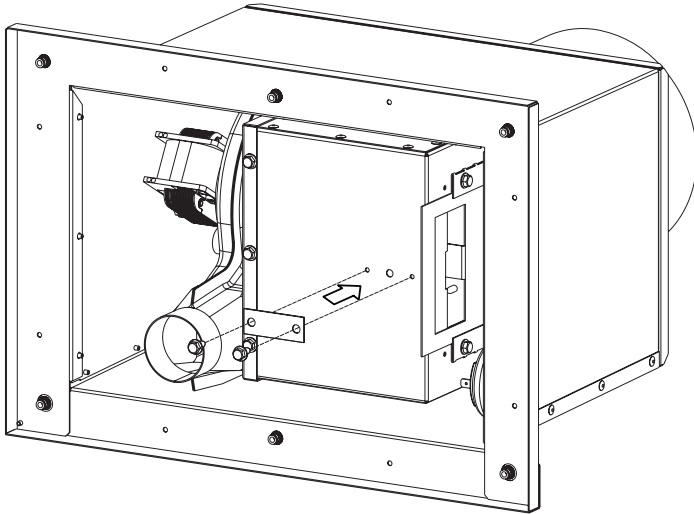
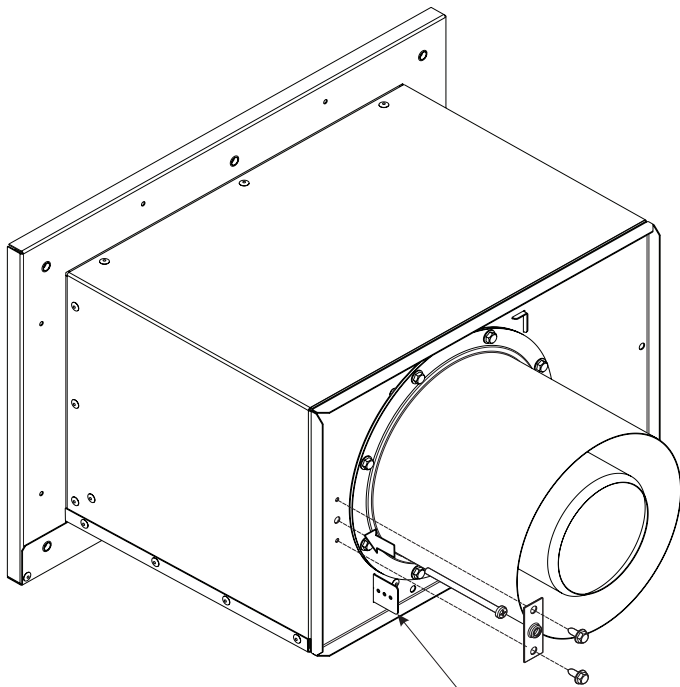

Figure 29

4. Thread the blender adjustment bolt into the blender plate through the intake air box rear and attach the bolt retainer with 2 #10 X 1/2 inch screws as shown in **Figure 30**.



BLENDER DOOR INDICATOR

Figure 30

ADJUSTMENT OF BLENDER PLATE FROM THE REAR

If adjusting the blender plate from the rear side, turning the blender adjustment bolt clockwise will open the blender door. Turning the blender door adjustment bolt counter clockwise will close the blender door. The blender door opening can be checked by measuring how far the blender door indicator protrudes from the rear of the unit.

BLENDER DOOR SETTING

1. Measure the height of the vent termination from the fireplace floor.
2. Measure the effective horizontal length of the vent run by using **Equation 2** below.

Equation 2

Effective horizontal length = Horizontal Run + 3 × (# of 90° elbows) + 1.5 × (# of 45° elbows)

3. Select the correct chart according to the BTU rating of the fireplace being installed.
4. Use the chart to determine the blender door setting using the height and effective horizontal length.

25,000-34,999 BTU

BLENDER DOOR SETTING

HEIGHT OF TERMINATION FROM FIREPLACE FLOOR	Dimensions in Inches																							
	1 1/8	1 1/8	1 1/8	1 1/8	1 1/8	1 1/8	1 1/8	1 1/8	1 1/8	1 1/8	1 1/8	1 1/8	1 1/8	1 1/8	1 1/8									
60	1 1/8	1 1/8	1 1/8	1 1/8	1 1/8	1 1/8	1 1/8	1 1/8	1 1/8	1 1/8	1 1/8	1 1/8	1 1/8	1 1/8	1 1/8									
55	1 1/8	1 1/8	1 1/8	1 1/8	1 1/8	1 1/8	1 1/8	1 1/8	1 1/8	1 1/8	1 1/8	1 1/8	1 1/8	1 1/8	1 1/8									
50	1	1	1	1	1	1	1	1	1	1	1	1	1	1	1									
45	1	7/8	7/8	7/8	7/8	7/8	7/8	7/8	7/8	7/8	7/8	7/8	7/8	7/8	7/8									
40	7/8	7/8	3/4	3/4	3/4	3/4	3/4	3/4	3/4	3/4	3/4	3/4	3/4	3/4	3/4									
35	3/4	3/4	3/4	3/4	3/4	3/4	3/4	3/4	3/4	3/4	3/4	3/4	3/4	3/4	3/4									
30	3/4	3/4	3/4	3/4	3/4	3/4	3/4	3/4	3/4	3/4	3/4	3/4	3/4	3/4	3/4									
25	5/8	5/8	5/8	5/8	5/8	5/8	5/8	5/8	5/8	5/8	5/8	5/8	5/8	5/8	5/8									
20	5/8	1/2	1/2	1/2	1/2	1/2	1/2	1/2	1/2	1/2	1/2	1/2	1/2	1/2	1/2									
15	1/2	1/2	1/2	1/2	1/2	1/2	1/2	1/2	1/2	1/2	1/2	1/2	1/2	1/2	1/2									
10		7/8	7/8	7/8	7/8	7/8	7/8	7/8	7/8	7/8	7/8	7/8	7/8	7/8	7/8									
5			3/4	3/4	3/4	3/4	3/4	3/4	3/4	3/4	3/4	3/4	3/4	3/4	3/4									
0																								
-5			3/4	3/4	3/4	3/4	3/4	3/4	3/4	3/4	3/4	3/4	3/4	3/4	3/4									
EFFECTIVE HORIZONTAL LENGTHS	0	5	10	15	20	25	30	35	40	45	50	55	60	65	70	75	80	85	90	95	100	105	110	
Dimensions In Feet																								

* For vent runs in gray, see page 4 for the restrictor installation.

35,000-44,999 BTU

BLENDER DOOR SETTING

HEIGHT OF TERMINATION FROM FIREPLACE FLOOR	Dimensions in Inches																						
	7/8	7/8	7/8	7/8	7/8	7/8	7/8	3/4	3/4	3/4	3/4	3/4	3/4	5/8	1/2	1/2	1/2	1/2					
60	7/8	7/8	7/8	7/8	7/8	7/8	7/8	3/4	3/4	3/4	3/4	3/4	3/4	5/8									
55	7/8	3/4	7/8	3/4	3/4	3/4	3/4	5/8	5/8	5/8	5/8	5/8	5/8	5/8	1/2								
50	3/4	3/4	3/4	3/4	5/8	5/8	5/8	1/2	1/2	1/2	1/2	1/2	1/2	1/2									
45	3/4	5/8	5/8	5/8	5/8	1/2	1/2	1/2	1/2	1/2	1/2	1/2	1/2	1/2	1/2								
40	5/8	5/8	1/2	5/8	1/2	1/2	1/2	1/2	3/8	3/8	3/8	3/8	3/8	3/8	1	1							
35	1/2	1/2	1/2	1/2	1/2	1/2	1/2	3/8	3/8	3/8	3/8	3/8	3/8	1	1	7/8	7/8						
30	1/2	1/2	1/2	1/2	3/8	3/8	3/8	1/4	3/8	1	1	7/8	7/8	3/4	3/4	3/4							
25	3/8	3/8	3/8	3/8	3/8	3/8	3/8	7/8	7/8	7/8	7/8	7/8	3/4	3/4	3/4	5/8	5/8	1/2					
20	3/8	1/4	1/4	1/4	1/4	3/4	3/4	3/4	3/4	3/4	3/4	3/4	3/4	5/8	5/8	1/2	1/2	1/2					
15	1/4	1/4	1/4	3/4	3/4	3/4	3/4	5/8	5/8	5/8	5/8	5/8	5/8	1/2	1/2	1/2	3/8	3/8					
10		5/8	5/8	5/8	5/8	5/8	5/8	1/2	1/2	1/2	1/2	1/2	1/2	1/2	3/8	3/8	3/8	1/4	1/4				
5			1/2	1/2	1/2	1/2	1/2	1/2	1/2	1/2	1/2	1/2	1/2	3/8	3/8	3/8	1/4	1/4	1/8				
0				1/2	1/2	1/2	1/2	3/8	3/8	3/8	3/8	3/8	3/8	1/4	1/4	1/4	1/4	1/4	1/8				
-5				1/2	1/2	1/2	1/2	3/8	3/8	3/8	3/8	3/8	3/8	1/4	1/4	1/4	1/4	1/8	1/8				
EFFECTIVE HORIZONTAL LENGTHS	0	5	10	15	20	25	30	35	40	45	50	55	60	65	70	75	80	85	90	95	100	105	110
Dimensions In Feet																							

* For vent runs in gray, see page 4 for the restrictor installation.

45,000-55,000 BTU

BLENDER DOOR SETTING

HEIGHT OF TERMINATION FROM FIREPLACE FLOOR	Dimensions in Inches																						
	5/8	5/8	5/8	5/8	5/8	5/8	5/8	1/2	1/2	1/2	1/2	1/2	1/2	1/2	1/2	1/2	1/2	1/2	1/2	1/2			
60	5/8	5/8	5/8	5/8	5/8	5/8	1/2	1/2	1/2	1/2	1/2	1/2	1/2	1/2	1/2	1/2	1/2	1/2	1/2	1/2			
55	5/8	5/8	5/8	1/2	1/2	1/2	3/8	3/8	3/8	3/8	3/8	3/8	3/8	3/8	3/8	3/8	3/8	3/8	3/8	3/8			
50	1/2	1/2	1/2	1/2	1/2	1/2	1/4	1/4	1/4	1/4	1/4	1/4	1/4	1/4	1/4	1/4	1/4	1/4	1/4	1/4			
45	1/2	3/8	3/8	3/8	3/8	3/8	1/4	1/4	1/4	1/4	1/4	1/4	1/4	1/4	1/4	1/4	1/4	1/4	1/4	1/4			
40	3/8	3/8	1/4	1/4	1/4	1/4	1/8	1/8	1/8	1/8	1/8	1/8	1/8	1/8	1/8	1/8	1/8	1/8	1/8	1/8			
35	1/4	1/4	1/4	1/4	1/4	1/4	3/4	3/4	3/4	3/4	3/4	3/4	3/4	3/4	3/4	3/4	3/4	3/4	3/4	3/4			
30	1/4	1/4	1/4	1/4	1/4	1/4	1/8	1/8	1/8	1/8	1/8	1/8	1/8	1/8	1/8	1/8	1/8	1/8	1/8	1/8			
25	1/8	1/8	1/8	1/8	1/8	1/8	1/8	1/8	5/8	5/8	5/8	5/8	5/8	5/8	5/8	5/8	5/8	5/8	5/8	5/8			
20	1/8	0	0	0	0	0	1/2	1/2	1/2	1/2	1/2	1/2	1/2	1/2	1/2	1/2	1/2	1/2	1/2	1/2			
15	0	0	0	1/2	1/2	1/2	3/8	3/8	3/8	3/8	3/8	3/8	3/8	3/8	3/8	3/8	3/8	3/8	3/8	3/8			
10		3/8	3/8	3/8	3/8	3/8	1/4	1/4	1/4	1/4	1/4	1/4	1/4	1/4	1/4	1/4	1/4	1/4	1/4	1/4			
5			1/4	1/4	1/4	1/4	1/4	1/4	1/4	1/4	1/4	1/4	1/4	1/4	1/4	1/4	1/4	1/4	1/4	1/4			
0				1/4	1/4	1/4	1/4	1/4	1/8	1/8	1/8	1/8	1/8	1/8	1/8	1/8	1/8	1/8	1/8	1/8			
-5				1/4	1/4	1/4	1/4	1/4	1/8	1/8	1/8	1/8	1/8	1/8	1/8	1/8	1/8	1/8	1/8	1/8			
EFFECTIVE HORIZONTAL LENGTHS	0	5	10	15	20	25	30	35	40	45	50	55	60	65	70	75	80	85	90	95	100	105	110
Dimensions In Feet																							

* For vent runs in gray, see page 4 for the restrictor installation.

MAINTENANCE AND SERVICE

This Power-Vent has no user-serviceable mechanical components. Contact your dealer or a qualified gas appliance service technician for all service and repair.

CHECK VENT SYSTEM

The fireplace and venting system should be inspected before initial use and at least annually by a qualified service person. Inspect the external vent cap on a regular basis to make sure that no debris is interfering with the air flow.

PAINTING POWER-VENT

Front fascia and inlet air box can be painted if desired. All surfaces to be painted must be thoroughly cleaned and scuffed with steel wool. Paint must have temperature rating over 750° F.

NOTE: Inlet air box paint cannot be cured above 190° F, due to a vacuum switch that is permanently attached to the box.

GENERAL INFORMATION

NOTE: The Power-vent inducer fan will run for 15 seconds after the fireplace is turned on. After this pre-purge time the ignition sequence will be initiated.

NOTE: The Power-vent inducer fan will run for 120 seconds after the fireplace is turned off to purge the system of exhaust gases.

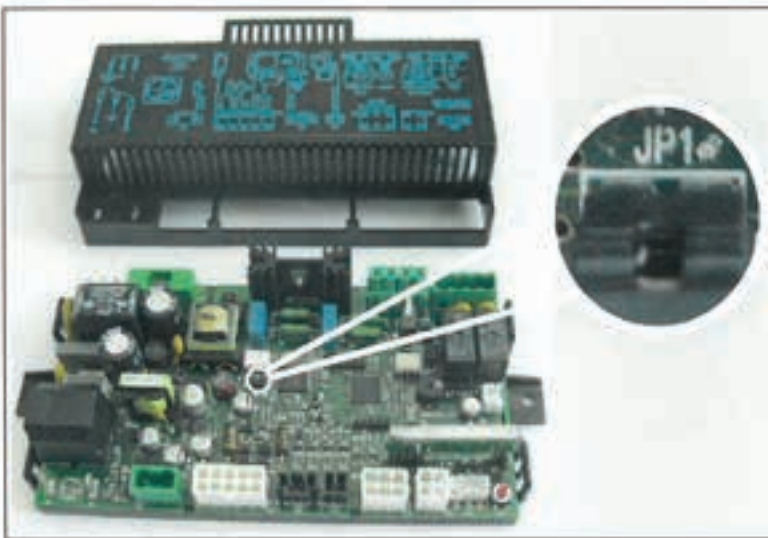



JP1 STATUS	IFC board enabled mode
OPEN 	FAN
CLOSED 	ATMO (DEFAULT)



PHOTO SHOWN HERE ENLARGEMENT FROM PAGE 4, FIGURE 4.

Figure 5 (Enlargement of photo from page 5)

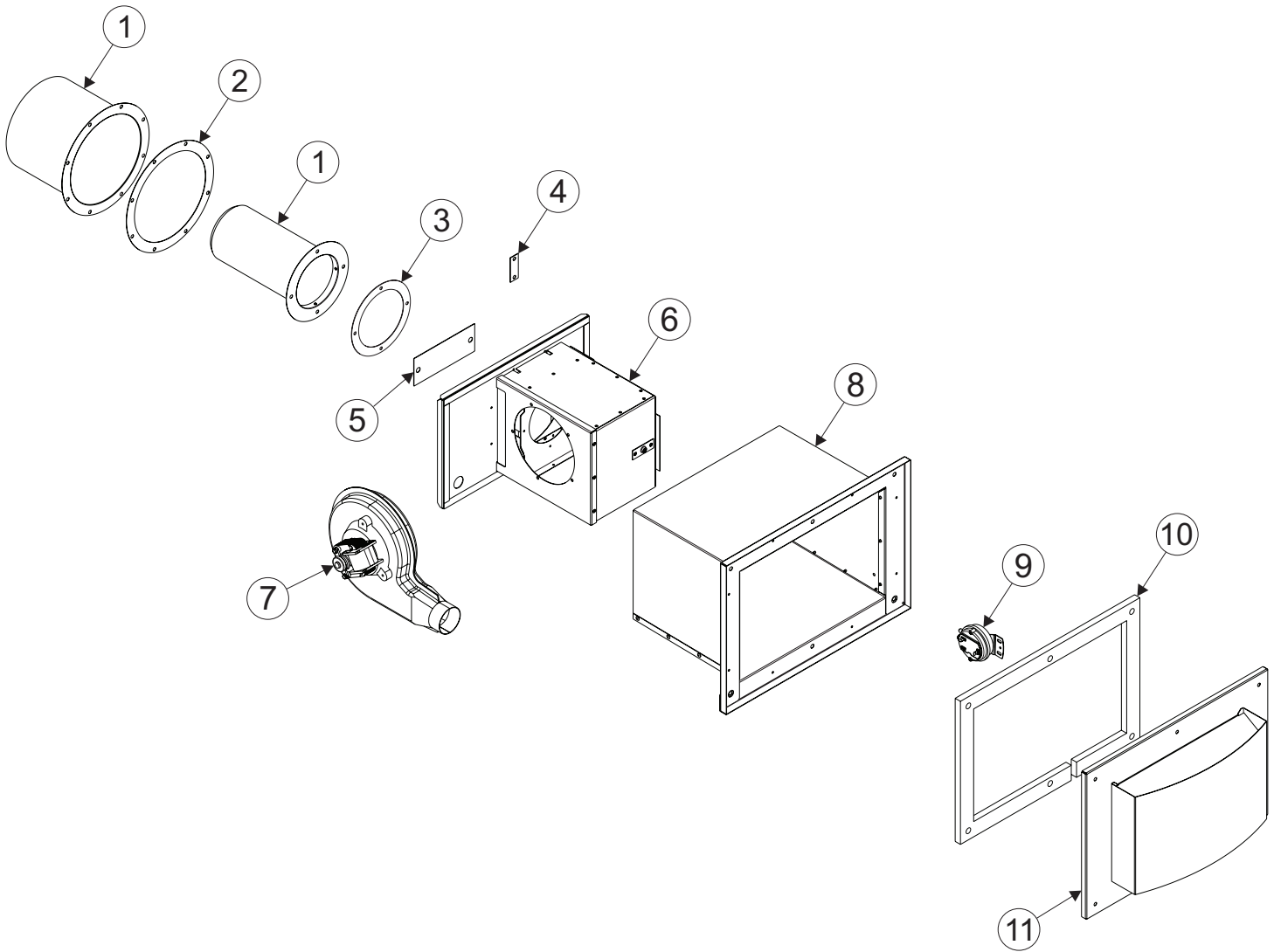

BLOWER ASSEMBLY PARTS LIST

INDEX NO.	PART NO.	DESCRIPTION	QTY.
1	R12577	Dura-vent Pipe Adapter	1
2	R12575	Inlet Gasket	1
3	M163	Gasket, Flue Connector	1
4	*	Cover	1
5	*	Flue Restrictor	1
6	*	Flue Box Assembly	1
7	38724	Inducer Assembly	1
8	*	Air Intake Box assembly	1
9	R12576	Vacuum Switch	1
10	R12578	Foam Gasket	1
11	38721	Fascia Assembly-Horizontal	1

* These items are not field serviceable.



**Empire Comfort Systems Inc.
Belleville, IL**

If you have a general question
about our products, please e-mail
us at info@empirecomfort.com.

If you have a service or repair
question, please contact your dealer.

SINCE 1932

www.empirecomfort.com