

IMPORTANT:
THESE INSTRUCTIONS ARE TO REMAIN
WITH THE HOMEOWNER
SAVE THESE INSTRUCTIONS



INSTALLATION AND OPERATING INSTRUCTIONS

SERIAL #

SAFETY NOTICE:

If this stove is not properly installed, a house fire may result. For your safety, follow the installation instructions. Contact local building or fire officials about restrictions and installation inspection requirements in your area.



**TESTED and LISTED
to ULC S627 / UL 1482**

Meets the U.S. Environmental Protection Agency's May 2020 Cribwood Particulate Emission Standards

MODEL: TN25C
SERIES: A
31010016 - Leg model
31010017 - Pedestal model



Contents

Specifications	3	Ember Protection	15
Efficiency and BTU Output.....	3	Securing Bracket Installation:	15
Safety and Maintenance	4	Procedure:.....	16
Maintenance Checks	5	Through Wall Installations	19
Weekly:.....	5	Mobile Home Installation	21
Monthly	5	Mobile Home Clearances.....	21
As Needed.....	5	Installation	21
When Cleaning the Chimney System:.....	5	Procedure:.....	21
Blower:.....	5	Combustion Air	22
Chimney Smoke and Creosote Formation.....	6	Leg Model	22
Chimney Fires	6	Baffle Board / Tube Installation	23
To Avoid a Chimney Fire.....	7	Removal	23
In the event of a Chimney Fire	7	Installation	23
Operation	8	Motor Control Removal & Installation	24
Wood Selection	8	Control Board Removal & Installation	25
DO NOT BURN:.....	8	Optional Battery Box Installation & Changing Batteries	26
How to Test Your Wood.....	9	Battery Box Installation	26
Lighting a Fire.....	9	Changing the Batteries.....	26
Normal Operation.....	9	Thermocouple Replacement	27
Restarting After Extended or Overnight Burns	10	Flue Thermocouple	27
Proper Draft.....	10	Firebox Thermocouple	28
Curing of the Paint Finish.....	10	Catalyst Monitoring	29
Ash Removal	10	Catalyst Removal & Installation	31
Disposal of Ashes.....	10	Optional Blower	33
Heat Output.....	10	Blower Installation.....	33
Stove Dimensions	11	Blower Operation	33
Residential Installation	11	Firebrick Installation	35
Catalyst Installation.....	12	Troubleshooting	36
Crate Removal	12	Replacement Parts	37
Residential Clearances.....	14	Rating Label	38
		Rating label location.....	38



PLEASE SAVE THESE INSTRUCTIONS

This manual describes the installation and operation of the True North, TN25C Series A Freestanding wood heater. This heater meets the 2020 U.S. Environmental Protection Agency's crib wood emission limits for wood heaters sold after May 15, 2015. Under specific test conditions this heater has been shown to deliver heat at rates ranging from 13,150 to 28,350 Btu/hr.

NOTE: WE STRONGLY RECOMMEND THAT SMOKE AND CARBON MONOXIDE DETECTORS BE INSTALLED IN THE AREA WHERE THE HEATER IS TO BE INSTALLED.

If smoke detectors have been previously installed, you may notice that they are operating more frequently. This may be due to curing of stove paint or fumes caused by accidentally leaving the fire door open. Do not disconnect the detectors.

SAFETY NOTICE: If this stove is not properly installed, a house fire may result. For your safety, follow the installation instructions. Contact local building or fire officials about restrictions and installation inspection requirements in you area.

Please read this entire manual before you install and use your new room heater. Failure to follow instructions may result in property damage, bodily injury, or even death.

Specifications

Efficiency and BTU Output

EPA Certified Emissions	1.1 grams per hour
LHV Tested Efficiency 1	75%
HHV Tested Efficiency 2	76%
EPA BTU Output 3	13,500 to 29,200 btu/hr
Peak BTU/Hr Output 4	29,200
Maximum Wood Length	20 inches
Ideal Wood Length	18 inches
Fuel	Seasoned Cord wood

1 Weighted Average Lower Heating Value (LHV) efficiency as tested using CSA B415 Performance testing of solid-fuel-burning heating appliances. LHV assumes the moisture is already in a vapor state so there is no loss of energy

2 Weighted Average Higher Heating Value (HHV) efficiency as tested using CSA B415 Performance testing of solid-fuel-burning heating appliances. HHV includes the energy required to vaporize the water in the fuel

3 The range of BTU outputs is based on efficiency using CSA B415 Performance testing of solid-fuel-burning heating appliances and burn rates from the low and high EPA tests using Douglas Fir dimensional lumber.

4 The Peak BTU/hr is based on efficiency using CSA B415 Performance testing of solid-fuel-burning heating appliances, the Maximum one hour High burn rate from the High Burn EPA test and the BTU content of cord wood (8600 btu/lb).

Experience will give you the right settings for proper combustion and efficient burning for the wood you are using. Remember the correct air inlet setting is affected by variables such as type of wood, outside temperature, chimney size and weather conditions. With practice, you will become proficient in operating your heater and will obtain the performance for which it was designed.

Safety and Maintenance

WARNING: Never use chemicals or any other volatile liquid to start a fire. Do not burn garbage, or flammable fluids such as gasoline, naphtha, or engine oil.

WARNING: ONLY USE MATERIALS SUPPLIED BY MANUFACTURER WHEN DOING MAINTENANCE OR REPLACEMENTS.

1. Burn only dry and well seasoned cord wood. The denser or heavier the wood when dry, the greater its heat value. This is why hardwoods are generally preferred. Green or wet wood will cause a rapid buildup of creosote. If you feel it is necessary to burn wet or unseasoned wood, do so only with the air inlet set open enough to maintain a good strong fire and fairly high chimney temperatures. Do not attempt to burn overnight using green wood or wet wood. Wet wood can cause up to 25% drop in heater output, as well as contributing significantly to creosote buildup.
2. Remove ashes frequently. Embers can roll out the door and create a fire hazard. Maintain a 1"(25mm) minimum ash base.
3. If glass becomes darkened through slow burning or poor wood, it can readily be cleaned with fireplace glass cleaner when stove is cold. Never scrape with an object that might scratch the glass. The type and amount of deposit on the glass is a good indication of the flue pipe and chimney buildup. A light brown dusty deposit that is easily wiped off usually indicates good combustion and dry, well-seasoned wood and therefore relatively clean pipes and chimney. On the other hand, a black greasy deposit that is difficult to remove is a result of wet and green wood and too slow a burning rate. This heavy deposit is building up at least as quickly in the chimney.
4. DOOR GASKETS - The gasket used for the True North (5/8"(16mm) medium density fiberglass rope) requires only light pressure to seal. This will prolong seal life. It is important that the door seal be maintained in good condition. Periodically inspect seals and replace if necessary. Follow instructions included in the Gasket kit obtainable from your nearest True North dealer.
5. DOOR GLASS - Do not slam loading door or otherwise impact glass. When closing door, make sure that no logs protrude to impact the glass. If the glass gets cracked or broken, it must be replaced before using the stove. Replacement glass can be obtained from your dealer. Use 9-1/4"(235mm) x 13-1/4"(337mm) x 5 mm. Ceramic glass only. Do not substitute with any other type.
 - -To remove broken glass, undo the four retaining screws and remove clamps, noting position for re-assembly. Remove all particles of glass. Be careful as they are very sharp. Install new glass complete with gasket. Replace clamps and screws.

CAUTION:

- do not overtighten, tighten screws very carefully
- do not clean glass when hot
- do not use abrasive cleaners on glass

6. The area where boost combustion air enters the firebox must be kept clear of excessive ash buildup which will block air flow. This area is at the front of the firebox.
7. Do not store wood within heater installation clearances, or within the space required for fuel loading and ash removal. Keep the area around the heater clean and free of loose combustibles, furniture, newspapers, etc.

8. Establish a routine for the fuel, wood burning and Lighting techniques. Check daily for creosote buildup in the firebox, until you are experienced and are operating the stove cleanly and safely.
9. Be aware that the hotter the fire, the less creosote is deposited. More frequent chimney cleaning may be necessary in mild weather or when burning "wet" or unseasoned wood.
10. Instruct all members of your family on the safe operation of the heater. Ensure they have enough knowledge of the entire system if they are expected to operate it. Stress the section on chimney fires and the importance of following the steps outlined "In Case of Chimney Fire".

Maintenance Checks

Check the following parts for damage such as cracks, excessive corrosion, burned out sections and excessive warping:

Note: Maintenance and Troubleshooting for the Catalyst Combustor can be found on page 29.

Weekly:

- Firebrick - Visual, for cracking.
- Door Gasket - sagging, placement, damage.

Monthly

- Brick rail tabs and brick rails.
- Back side of airwash chamber.
- Top baffle board.
- Baffle Tubes.

As Needed

- It is recommended that the chimney be inspected a minimum of every 2 months and cleaned as needed a minimum of 2 times a year.

When Cleaning the Chimney System:

- Top heat shield and mounting bolt.
- Brick Rails.
- Manifold.

- Replace the baffle tubes if they show signs of cracking or breakage.

- Please contact your Dealer for replacement parts if you experience any of the damage listed above.

Continuing to operate your stove with broken parts may accelerate damage to other parts and will void your warranty

Blower:

- The blower should be cleaned out a minimum every six months by using a vacuum on the grill openings in the back and bottom of the blower casing to remove any dust and debris.

Chimney Smoke and Creosote Formation

When wood is burned slowly, it produces tar and other organic vapors, which combine with expelled moisture to form creosote. The creosote vapors condense in the relatively cool chimney flue of a slow burning fire. As a result, creosote residue accumulates on the flue lining. When ignited, this creosote makes an extremely hot fire. The chimney connector and chimney should be inspected periodically (at least once every two months) during the heating season to determine if a creosote buildup has occurred. If creosote has accumulated (3 mm. or more), it should be removed to reduce the risk of a chimney fire.

1. Highest smoke densities and emissions occur when a large amount of wood is added to a bed of hot coals and the air inlet is closed. The heated wood generates smoke, but without ample air, the smoke cannot burn. Smoke-free, clean burning requires small fuel loads, two or three logs at a time or 1/4 to 1/2 of fuel load and leaving the air inlet relatively wide open, especially during the first 10 to 30 minutes after each loading, when most of the smoke generating reactions are occurring. After 30 minutes or so, the air inlet can be turned down substantially without excessive smoke generation. Wood coals create very little creosote-producing smoke.
2. The cooler the surface over which the wood smoke is passing, the more creosote will be condensed. Wet or green wood contributes significantly to creosote formation as the excess moisture that is boiled off cools the fire, making it difficult for the tars and gases to ignite, thus creating dense smoke and poor combustion. This moisture-laden smoke cools the chimney, compounding the problem by offering the smoke the ideal place to condense.

In summary, a certain amount of creosote is inevitable. Regular inspection and cleaning is the solution. The use of dry, seasoned wood and ample combustion air will help to minimize annoying smoke emissions and creosote buildup.

Chimney Fires

The dangerous side effect of excessive creosote buildup is a chimney fire. This causes much higher than normal temperatures in the chimney and on its exterior surfaces. Temperatures inside the chimney can exceed 2000°F (1100°C). Ignition of nearby or touching combustible material is more likely during a chimney fire. Proper clearances are critical to prevent damage during such a fire.

Chimney fires are easy to detect; they usually involve one or more of the following:

- Flames and sparks shooting out of the top of the chimney
- A roaring sound
- Vibration of the chimney

To Avoid a Chimney Fire

1. Burn wood cleanly. Do not burn wet wood or turn down the unit too quickly after loading.
2. Do not let creosote build up to a point where a chimney fire is possible.
3. Do not have fires in the heater that may ignite chimney fires. These are excessively hot fires, such as when burning household trash, cardboard, Christmas tree limbs, or even ordinary fuel wood; (e.g. with a full load on a hot bed of coals and with the air inlet wide open for more time than is needed to completely char a fresh fuel load.)
4. The Chimney and connector pipe should be inspected /cleaned periodically.

In the event of a Chimney Fire

Have a fire extinguisher handy. Contact your local, municipal or state/provincial fire authority for further information on how to handle a chimney fire. It is most important that you have a clearly understood plan on how to handle a chimney fire.

5. Close down the air inlet on the stove.
6. Call the local fire department.
7. Prepare to evacuate to ensure everyone's safety. Have a well understood plan of action for evacuation. Have a place outside where everyone is to meet.
8. After the chimney fire is out, the chimney must be cleaned and checked for stress and cracks before starting another fire. Also check combustibles around the chimney and the roof. The services of a competent or certified installer, (certified by the Wood Energy Technical Training program (WETT) - in Canada, National Fireplace Institute (NFI) - in U.S.A., are strongly recommended.

Operation

CAUTION: Hot while in operation. Keep children, clothing and furniture away. Contact may cause skin burns.

WARNING: Always keep loading door closed when burning. This heater is not designed for open door burning.

WARNING: No alteration or modification of the combustion air control assembly is permitted. Any tampering will void warranty and could be very hazardous.

WARNING: Do not use grates or andirons to elevate the fuel. Burn directly on the fire bricks. Replace broken or missing bricks. Failure to do so may create a hazardous condition.

WARNING: Never use gasoline, gasoline-type lantern fuel, kerosene, charcoal lighter fluid, or similar liquids to start or 'freshen up' a fire in this heater. Keep all such liquids well away from the heater while in use.

Your True North heater is designed for maximum overall efficiency at a moderate firing rate. Over firing the appliance will shorten the life of the product. Failure to rectify an over firing condition can be hazardous and may void the manufacturer's warranty. Too slow a burn may contribute to creosote buildup and lowers combustion efficiency.

Wood Selection

This heater is designed to burn natural wood only. Higher efficiency and lower emissions generally result when burning air-dried seasoned hardwoods, as compared to softwoods or to green or freshly cut hardwoods.

Wood should be properly air dried (seasoned) for six months or more. Wet or damp wood will cause the fire to smoulder and produce large amounts of smoke and creosote. Wet wood also produces very little heat and tends to go out often. Wood should be stored under cover away from open flame or heat sources.

DO NOT BURN:

• Salt water wood *	• Treated wood
• Wet or green wood	• Coal/charcoal
• Garbage*	• Solvents
• Lawn clippings/yard waste	• Unseasoned wood
• Railroad ties	• Manure or animal remains
• Materials containing rubber, including tires	• Materials containing plastic
• Waste petroleum products, paints or paint thinners, or asphalt products	• Materials containing asbestos
• Construction or demolition debris	• Paper products, cardboard, plywood, or particleboard.

* These materials contain chlorides which will rapidly destroy metal surfaces and void warranty.

Burning these materials may result in the release of toxic fumes or render the heater ineffective and cause smoke.

The prohibition against burning these materials does not prohibit the use of fire starters made from paper, cardboard, saw dust, wax and similar substances for the purpose of starting a fire in an affected wood heater.

Do not burn anything but cord wood. Other fuels, e.g. lump charcoal, can produce large amounts of carbon monoxide, a tasteless, odorless gas that can kill. Under no circumstances should you attempt to barbecue in this heater.

How to Test Your Wood

Add a large piece of wood to the stove when it has a good large bed of coals. It is dry if it is burning on more than one side within one minute. It is damp if it turns black and lights within three minutes. If it sizzles, hisses and blackens without igniting in five minutes it is soaked and should not be burned.

Lighting a Fire

Remove the retaining clip on the front of the baffle before lighting for the first time.

1. Move air control lever to the left-most position (maximum firing rate) and open door.
2. Place crumpled newspaper in the centre of the heater and crisscross with several pieces of dry kindling. Add a few small pieces of dry wood on top.
3. Ignite the paper and leave the door ajar approximately 1/2"(13mm) - 1"(25mm) until the wood kindling is fully engulfed in flame. **DO NOT LEAVE UNATTENDED.**
4. After the kindling is fully engulfed add a few small logs. Close door.
5. Begin normal operation after a good coal base exists and wood has charred.

Normal Operation

WARNING: This wood heater need periodic inspection and repair for proper operation. This wood heater has a manufacturer-set minimum low burn rate that must not be altered. It is against federal regulations to alter this setting or otherwise operate this wood heater in a manner inconsistent with the operating instructions in this manual.

1. Set air control to a desired setting. If smoke pours down across the glass (waterfall effect) this indicates you have shut the control down too soon or you are using too low a setting. The wide range control panel makes finding the desired setting for your application easy. As every home's heating needs vary (i.e., insulation, windows, climate, etc.) the proper setting can only be found by trial and error and should be noted for future burns.
2. To refuel, adjust air control to high, and give the fire time to brighten. Open the door slowly, this will prevent back puffing.
3. Use wood of different shape, diameter and length (up to 18" (457mm)). Load your wood and try to place the logs so that the air can flow between them. Always use dry wood.
4. Do not load fuel to a height or in such a manner that would be hazardous when opening the door.
5. For extended or overnight burns, un-split logs are preferred. Remember to char the wood completely on maximum setting before adjusting air control for overnight burn/low burn. (see step 1 concerning "waterfall effect")

Restarting After Extended or Overnight Burns

1. Open door and rake hot embers towards the front of the heater. Add a couple of dry, split logs on top of embers, close door.
2. Adjust air control to high (control lever to the left) and in just a few minutes, logs should begin burning.
3. After wood has charred, reset air control to desired setting.
4. To achieve maximum firing rate, set air control lever to the left-most position. Do not use this setting other than for starting or preheating fresh fuel loads.

DO NOT OVER FIRE THIS HEATER: Attempts to achieve heat output rates that exceed heater design specifications can result in permanent damage to the heater and chimney.

Proper Draft

1. Draft is the force that pulls air into the appliance and up through the chimney. The amount of draft in your chimney depends on the length of the chimney, local geography, nearby obstructions and other factors.
2. Too much draft may cause excessive temperatures in the appliance. An uncontrollable burn or a glowing red stove part or chimney indicates excessive draft.
3. Inadequate draft may cause back puffing into the room and plugging of the chimney. Smoke leaking into the room through appliance and chimney connector joints indicates inadequate draft.

Curing of the Paint Finish

To achieve the best finish, the paint on your stove must be baked on. Follow the Paint Curing instructions. When burning your stove for the first 2-3 times it is very important that the room be well ventilated. Open all windows and doors. Smoke and fumes caused by the curing process may cause discomfort to some individuals.

Ash Removal

Caution: Ashes are to be removed only when the heater is cold. Whenever ashes get 3"(76mm) to 4"(102mm) deep in your firebox, and when fire has burned down and cooled, remove excess ashes. Leave an ash bed approximately 1" (25 mm) deep on the firebox bottom to help maintain a hot charcoal bed.

Disposal of Ashes

Ashes should be placed in a metal container with a tight fitting lid. The closed container of ashes should be placed outside on a non-combustible floor or on the ground, well away from all combustible materials, pending final disposal. If the ashes are disposed of by burial in soil or otherwise locally dispersed, they should be retained in closed container until all cinders have thoroughly cooled. Other waste should not be placed in this container.

Heat Output

Experience will give you the right settings for proper combustion and efficient burning. Remember that the correct air inlet setting is affected by variables such as type of wood, outside temperature, chimney size and weather conditions. With practice, you will become proficient in operating your heater and will obtain the performance for which it was designed.

Stove Dimensions

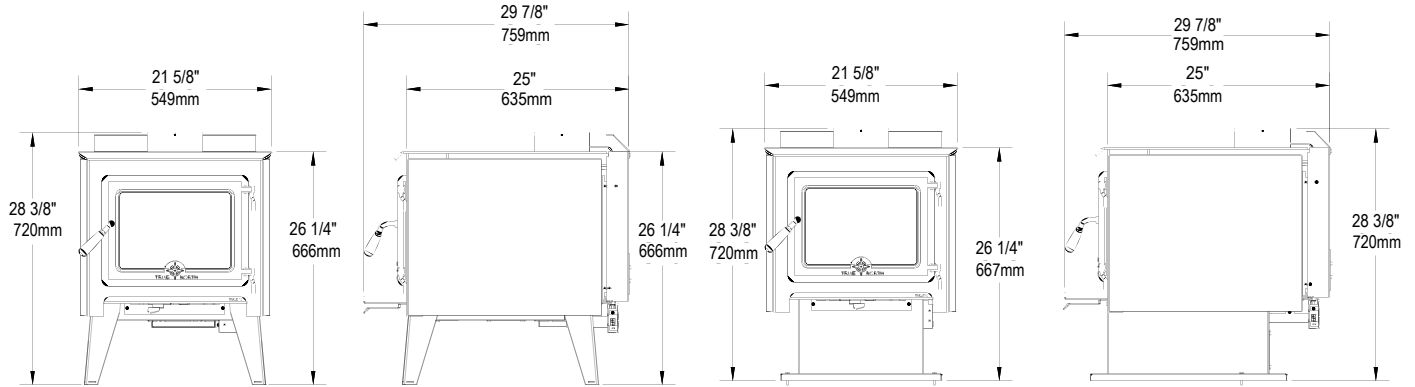

Figure 1: TN25C Dimensions.

Residential Installation

Warning: Under no circumstances is this heater to be installed in a makeshift or "temporary" manner. It may be fired only after the following conditions have been met.

- **DO NOT CONNECT THIS UNIT TO A CHIMNEY FLUE SERVING ANOTHER APPLIANCE.**
- **DO NOT INSTALL IN A SLEEPING ROOM.(U.S. INSTALLATIONS ONLY)**
- **THIS ROOM HEATER MUST BE CONNECTED TO:**
 1. **A CHIMNEY LISTED TO: UL 103HT (USA) or ULC-S629 (CANADA) or**
 2. **A CODE APPROVED MASONRY CHIMNEY WITH A LISTED FLUE LINER.**
- DO NOT ATTEMPT TO CONNECT THIS HEATER TO ANY AIR DISTRIBUTION DUCT.
- The services of competent installer are strongly recommended.
- Outside combustion air or fresh air into the room may be required in your area, consult local building codes (see Combustion Air section).



Crate Removal

1. Carefully remove wood top and supports.
2. Remove plastic cover.
3. Remove all screws holding the Legs or Pedestal, to the Pallet.

Catalyst Installation

DO NOT OPERATE WITH CATALYST REMOVED.

The Catalyst comes packaged inside the unit and needs to be installed before lighting the unit.

Installation

1. Remove the catalytic combustor from the packaging.
2. Insert the catalytic combustor into the flue collar from above.



Figure 2: Insert combustor into flue.

3. Position the end of the catalytic combustor down beside the flue thermocouple. (Be careful not to bend the thermocouple.)



Figure 3: Combustor next to thermocouple.

4. Rotate the catalytic combustor clock-wise under the thermocouple.



Figure 4: Rotate combustor under thermocouple.

5. Align the catalytic combustor over the combustor bracket.



Figure 5: Position over combustor bracket.

6. Carefully place the catalytic combustor into the combustor bracket.

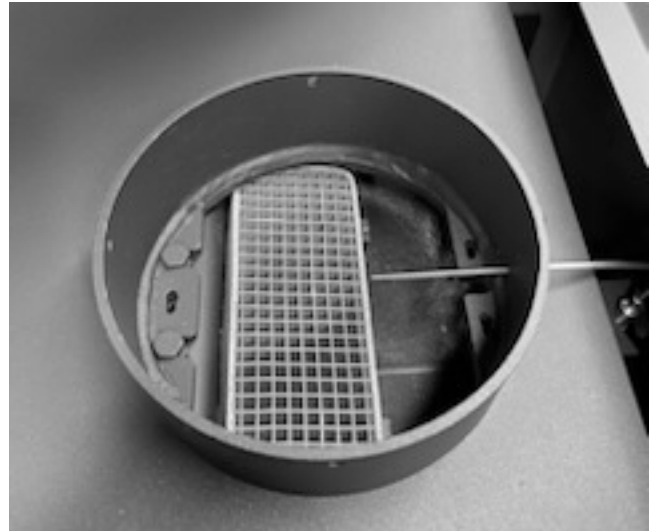

Figure 6: Placed into combustor bracket.

7. Remove the thermocouple guard from inside the unit and place it inside the flue collar, engaging the tabs in the slots.

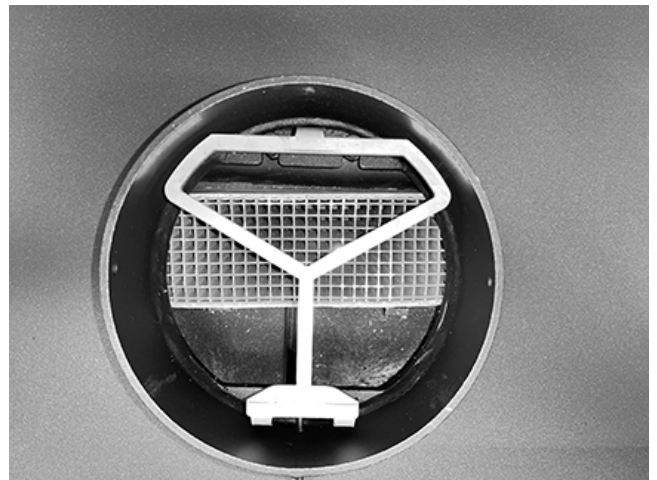

Figure 7: Install thermocouple guard.

Residential Clearances

- BOTH CHIMNEY SYSTEM AND CONNECTOR MUST BE 6" (150mm) DIAMETER AND LISTED TO:**
CANADA - CONNECTOR - LISTED to ULC S-641 and CHIMNEY LISTED to ULC-S-629
USA - CONNECTOR AND CHIMNEY LISTED to UL-103 HT

1. Residential Clearances to Combustible surfaces and materials;

This heater may be installed using a single-wall connector (smoke pipe) as per local and National fire and Installation codes. See Single wall Connector in figure 2. Clearances may be reduced with various heat shielding or insulating materials. Consult local and national fire codes and authorities for approval

For close clearances, use a listed double-wall connector, See (Figure 8). "Double Wall Connector

Mobile Home installation see "Mobile Home Installation"(Figure 14).

Minimum Clearance to Combustibles

Single Wall Connector - Residential

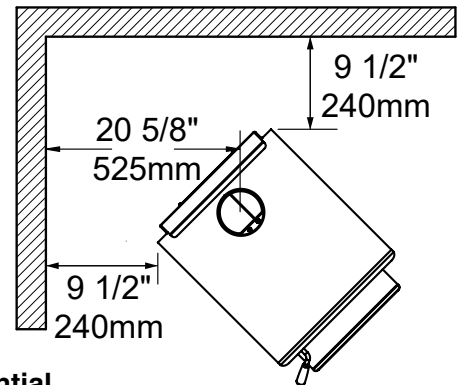
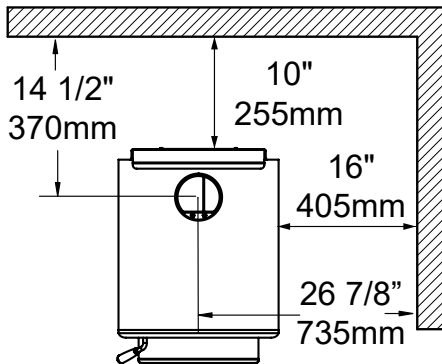

Double Wall Connector - Residential

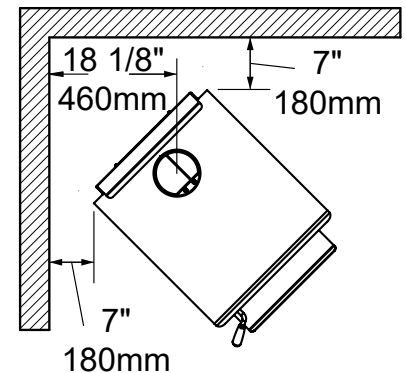
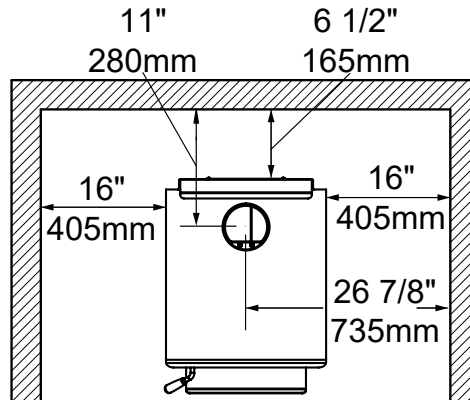
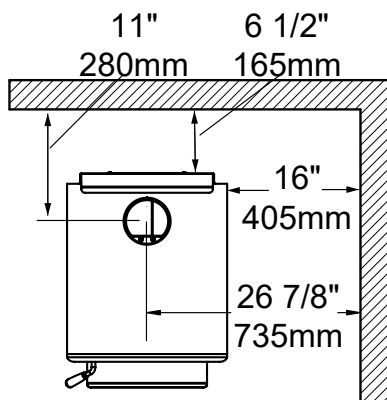

Alcove: Min. Height 7' [2.13m]
Max. Depth 3' [915mm]

Figure 8: TN25 C clearances.

Ember Protection

The stove may be installed on a combustible floor, provided ember protection (UL 1618 type 1) made from a non-combustible material (a minimum K value of 23.7 btu/ft h ° F) the equivalent of 20 Gauge steel or tile is used.

This protection must extend as follows:

In Canada: 18" (457 mm) from the loading door on the firing side and 8" (203 mm) from the sides. See Figure 9, below.

In USA: 16" (406 mm) to the front of the firebox and 8" (203 mm) from the sides of the fuel loading door opening. See Figure 10, below. This protection is also required under a horizontal chimney connector and 2" (51 mm) beyond each side of it.

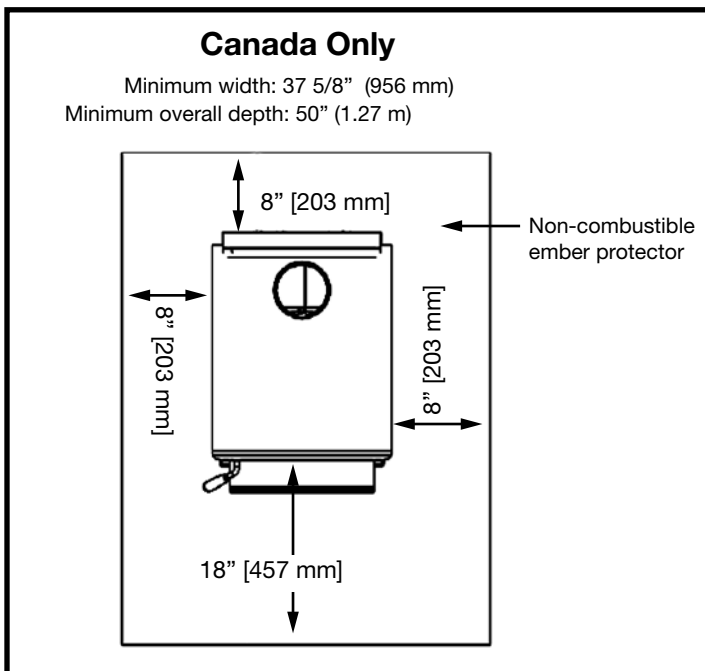

Figure 9: TN25C Floor protector Canada.

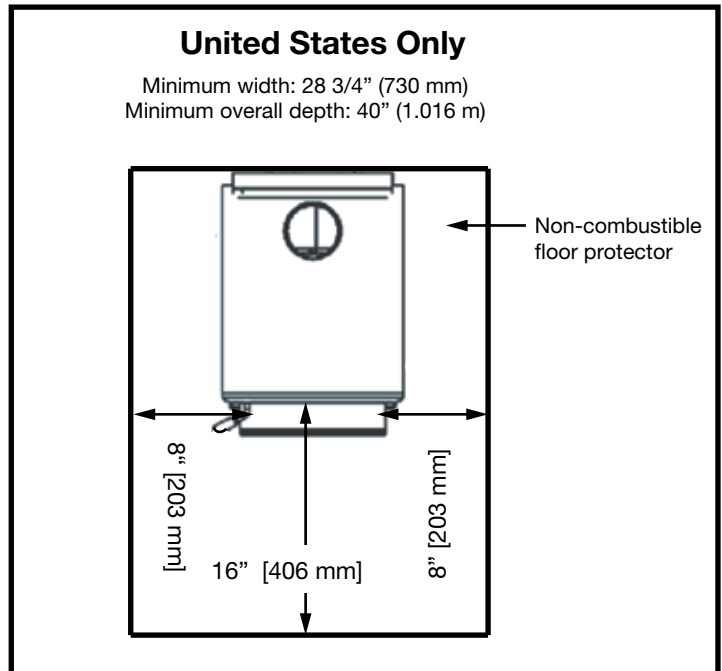

Figure 10: TN25C Floor protector U.S..

Securing Bracket Installation:

These will be needed to anchor the stove in a mobile home installation and are recommended when installing combustion air to prevent movement of the unit and separation of the combustion air intake.

1. The hold down brackets are provided in a bag with the unit. Insert the brackets by sliding them through the slots in the rear legs. Then lag the bracket to the floor or hearth pad.



Figure 11: Securing bracket.

Procedure:

Follow the chimney manufacturer's instructions, The installation instructions included below are just general steps.

1. Position stove and floor protection (with hole for combustion air if required) in accordance with the clearances as stated on the label and in Figure 9 on page 15 (Canada) and Figure 10 on page 15 (U.S.A.).
2. Mark the position for the hole in the ceiling and roof by using a string and plumb-bob.
3. Check that the intended location will not interfere with floor joists, ceiling joists or rafters before proceeding further.
 - Cut a hole in the ceiling and roof to suit the chimney system and frame in the sides.
 - Install roof or ceiling support as required in the installation.
 - Install the roof flashing, be sure to secure the flashing and seal with the appropriate sealant as per instructions
 - Assemble the chimney sections so the finished length is resting on the support and protruding through the roof. Install the radiation shield. Avoid having chimney joints between ceiling and roof.
 - Install the storm collar and required chimney sections to achieve a safe height. Attach rain cap and check system for leaks.
4. If double-wall connector pipe is to be connected between the stove and the listed insulated chimney,
 - Use listed double-wall connector and install all components to the connector pipe manufacturer's installation requirements.
5. If smoke pipe is being used to connect between the stove and the listed insulated chimney,
 - As short and straight as possible, use 6"(150mm) diameter, minimum 24 gauge black pipe, that is clean and in new condition.
Install the smoke pipe (chimney connector), crimped edge of the pipe down and inside the stove's collar. This will carry any liquid creosote or condensation back into the stove. Use holes provided in stove collar to secure pipe with three screws.
 - Install the remaining lengths of pipe, one on top of the other to the finished height of the listed insulated chimney adapter and secure to each other. A slip-section will make attaching the smoke pipe to the chimney system adapter easier. Secure with 3 screws at each joint.
 - The Smoke pipe/chimney connector shall not pass through an attic, roof space, closet or similar concealed space, or a floor, or ceiling. Where passage through a wall, or partition of combustible material is desired, the installation shall conform to CAN/CSA-B365, INSTALLATION CODE FOR SOLID-FUEL-BURNING APPLIANCES AND EQUIPMENT or NFPA 211 STANDARD FOR CHIMNEYS, FIREPLACES AND SOLID FUEL BURNING APPLIANCES

The chimney may incorporate an offset. To do this safely, all sections of listed connector, offset elbows and chimney section must be screwed together by at least three sheet metal screws per joint. The chimney must be suitably supported by the chimney manufacturer's listed offset support. And all vent manufacturer or national fire code clearances to combustibles must be observed.

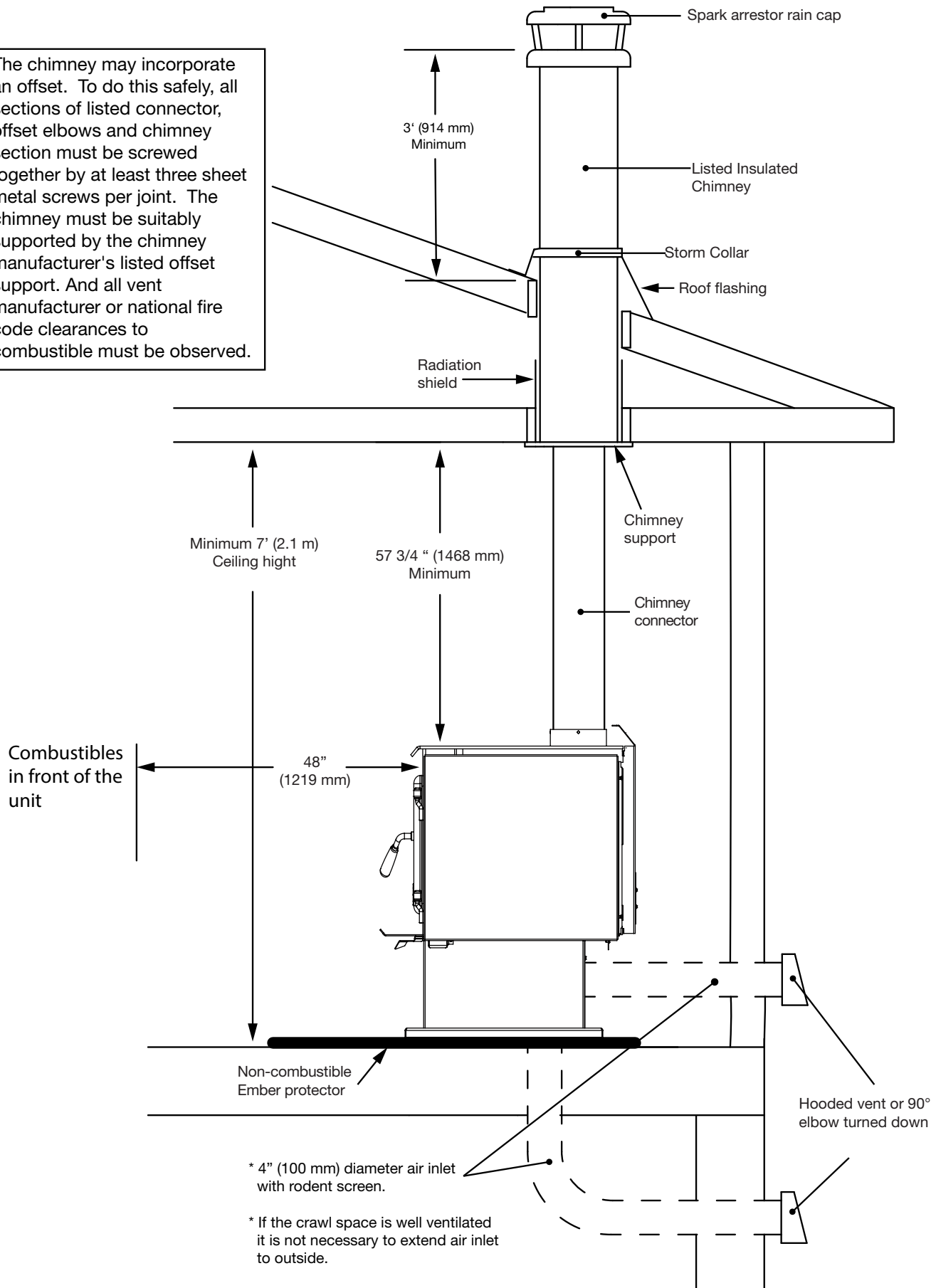

Figure 12: Mobile home or typical home installation.

Connecting to a masonry chimney

Ensure that the chimney is in good condition and meets local building codes. Your stove may work better if the chimney is fully lined with a stainless steel liner, this is because the liner will retain heat and promote draft. The chimney flue or liner should be the same size as the stove outlet for optimal performance. Reducing or increasing the flue size may adversely affect stove performance. Chimney flue exit is to be 3 feet (1 m.) above the roof and two feet (0.6 m.) above highest projection within 10 feet (3 m.). The installation must meet all local codes. Do not connect this unit to a chimney flue serving another appliance. Minimum system height is 12 feet (3.0 m.) (Measured from top of appliance).

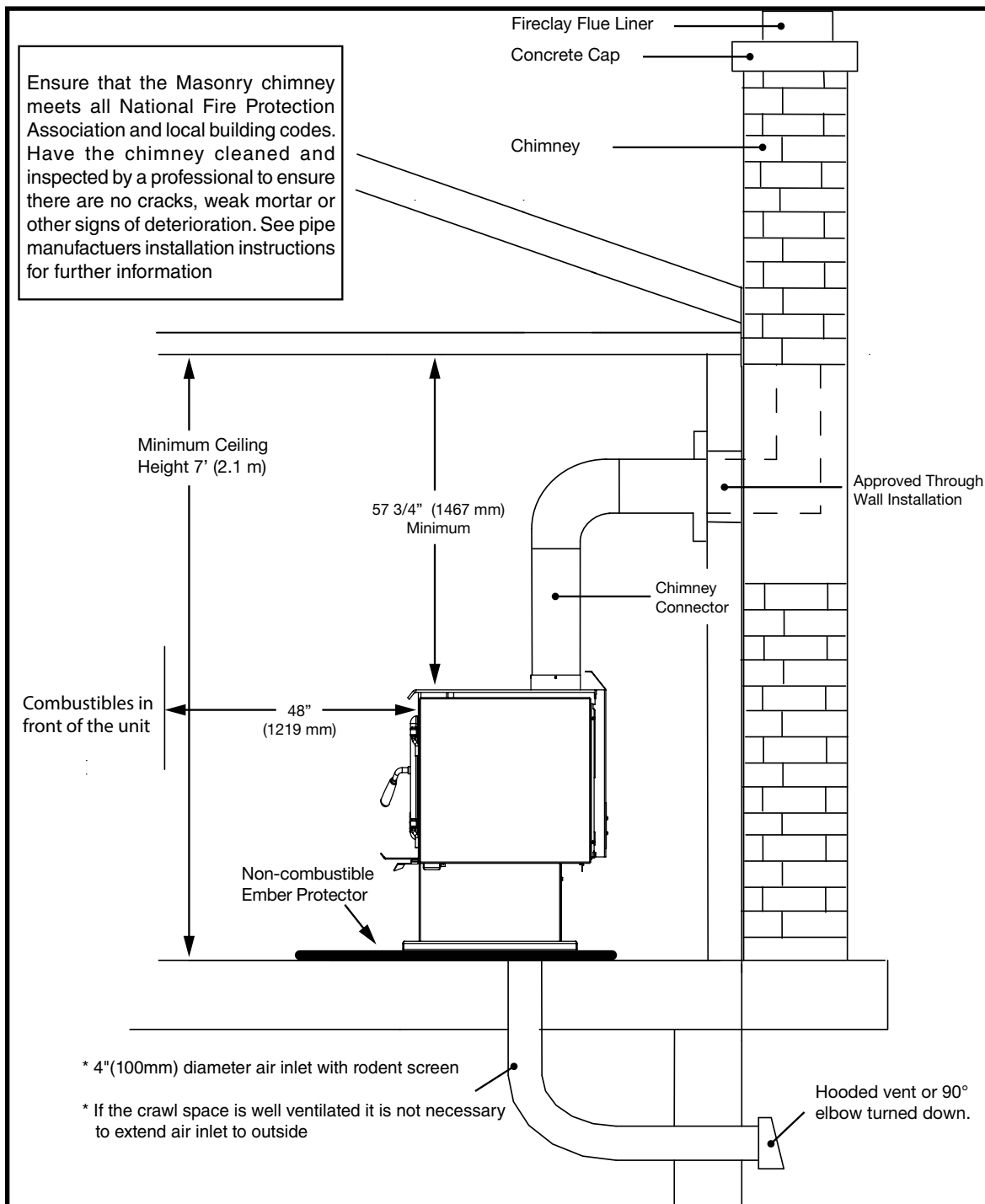

Figure 13: Venting to a masonry chimney.

**Through Wall Installations
(as per NFPA 211-2013)**

ATTENTION: VAPOR BARRIER MUST BE MAINTAINED WHEREVER CHIMNEY OR OTHER COMPONENTS PENETRATE TO THE EXTERIOR OF THE STRUCTURE. SEE LOCAL BUILDING CODES FOR PROPER AND APPROVED METHODS OF MAINTAINING VAPOR BARRIER.

System A. Minimum 3.5 in. (90 mm) thick brick masonry wall framed into combustible wall with a minimum of 12 in. (305 mm) brick separation from clay liner to combustibles. Fireclay liner (ASTM C 315, Standard Specifications for Clay Fire Linings, or equivalent), minimum 5/8 in. (16 mm) wall thickness, shall run from outer surface of brick wall to, but not beyond, the inner surface of chimney flue liner and shall be firmly cemented in place.

Clearance 12 in. (305mm)

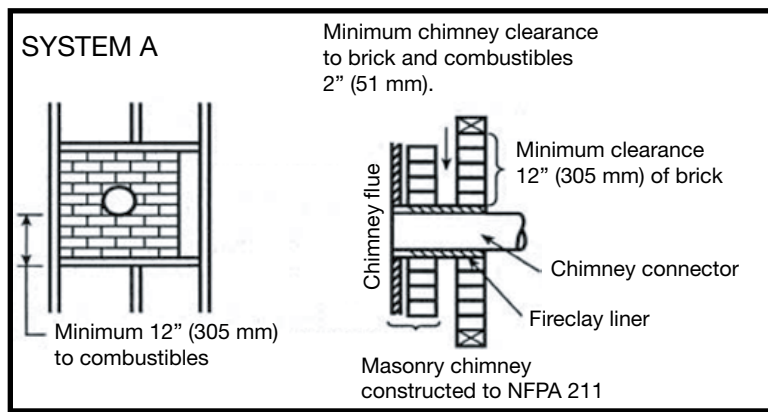

System B. Solid-Insulated, listed factory-built chimney length of the same inside diameter as the chimney connector and having 1 in. (25.4 mm) or more of insulation with a minimum 9 in. (229 mm) air space between the outer wall of the chimney length and combustibles.

The inner end of the chimney length shall be flush with the inside of the masonry chimney flue and shall be sealed to the flue and to the brick masonry penetration with non-water-soluble refractory cement. Supports shall be securely fastened to wall surfaces on all sides.

Fasteners between supports and the chimney length shall not penetrate the chimney liner.

Clearance 9 in. (229mm)

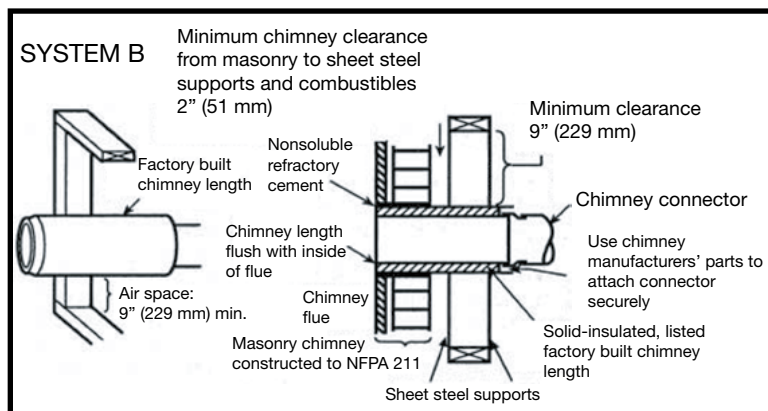

System C. Sheet steel chimney connector, minimum 24 gauge [0.024 in. (0.61 mm)] in thickness, with a ventilated thimble, minimum 24 gauge [0.024 in. (0.61 mm)] in thickness, having two 1 in. (25.4 mm) air channels, separated from combustibles by a minimum of 6 in. (152 mm) of glass fiber insulation. Opening shall be covered, and thimble supported with a sheet steel support, minimum 24 gauge [0.024 in. (0.61 mm)] in thickness.

Supports shall be securely fastened to wall surfaces on all sides and shall be sized to fit and hold chimney section. Fasteners used to secure chimney section shall not penetrate chimney flue liner.

Clearance: 6 in. (152mm)

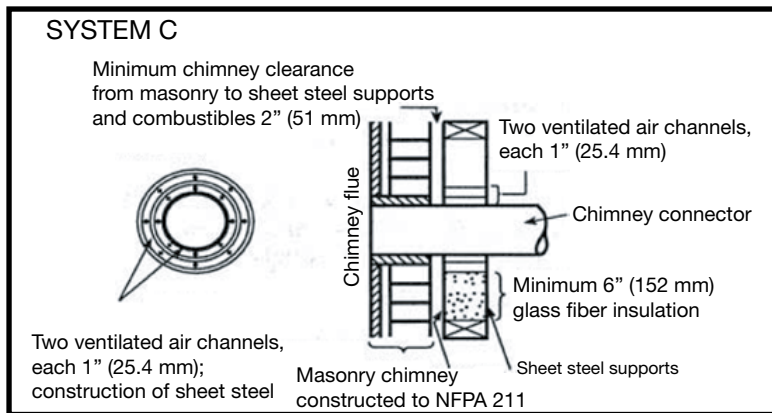

System D. Solid-Insulated, listed factory-built chimney length with an inside diameter 2 in. (51 mm) larger than the chimney connector and having 1 in. (25.4mm) or more of insulation, serving as a pass-through for a single-wall sheet steel chimney connector of minimum 24 gauge [0.024 in. (0.61 mm)] thickness, with a minimum 2 in. (51 mm) air space between the outer wall of chimney section and combustibles.

Minimum length of chimney section shall be 12 in. (305 mm). Chimney section concentric with and spaced 1 in. (25.4 mm) away from connector by means of sheet steel support plates on both ends of chimney section. Opening shall be covered, and chimney section supported on both sides with sheet steel supports of minimum 24 gauge [0.024 in. (0.61 mm)] thickness.

Supports shall be securely fastened to wall surfaces on all sides and shall be sized to fit and hold chimney section. Fasteners used to secure chimney section shall not penetrate chimney flue liner.

Clearance: 2 in. (51mm)

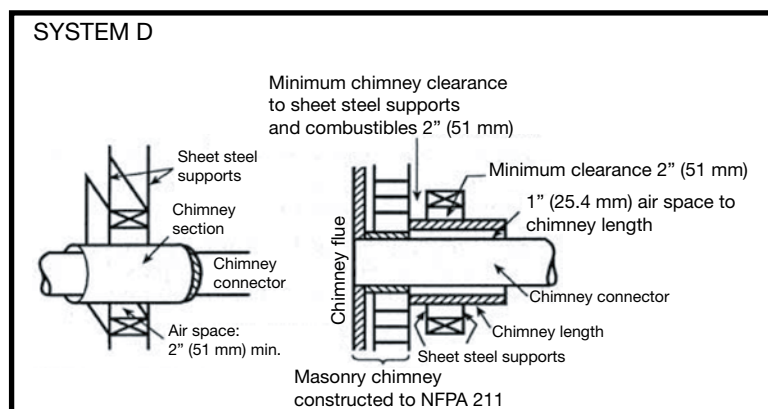

Mobile Home Installation

Warning: Under no circumstances is this heater to be installed in a makeshift or "temporary" manner. It may be fired only after the following conditions have been met.

- **DO NOT CONNECT THIS UNIT TO A CHIMNEY FLUE SERVING ANOTHER APPLIANCE.**
- **DO NOT INSTALL IN A SLEEPING ROOM.(U.S. INSTALLATIONS ONLY)**

**THIS HEATER MUST BE INSTALLED WITH LISTED DOUBLE-WALL CONNECTOR. BOTH CHIMNEY SYSTEM AND CONNECTOR MUST BE 6"(150mm) DIAMETER AND LISTED TO:
IN CANADA - ULC S-641 LISTED CONNECTOR AND ULC-S-629 LISTED CHIMNEY,
IN USA - UL-103 HT LISTED CONNECTOR AND CHIMNEY**

- Outside combustion air supply must be used for Mobile Home installations see page 22

Mobile Home Clearances

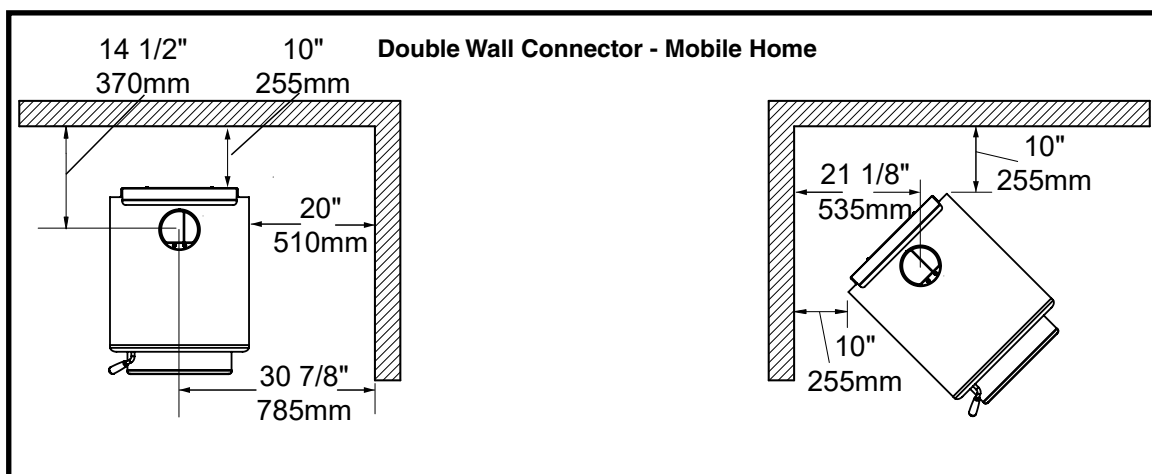

Figure 14: TN25 C Mobile home clearances.

Installation

Minimum chimney height from top of unit is 12' (3.66 m) or as per chimney manufacturers roof clearances whichever is greater.

NOTE: Longer chimney lengths and different pitch flashings may be used. Install all components to the connector or chimney manufacturer's installation requirements. Consult your chimney supplier for installation advice.

Procedure:

Follow Chimney Manufacturer's Installation Instructions for installation or removal of the chimney.

WARNING: THE STRUCTURAL INTEGRITY OF THE MOBILE HOME FLOOR, WALL AND CEILING/ROOF MUST BE MAINTAINED.

Note: See "Combustion Air" on page 22.

- Attach stove to floor using two 1/4" x 1" or longer lag screws.
If installing a leg model, insert anchor tabs into slot on bottom of two rear legs and secure to floor with 1/4" x 1" or longer lag screws (Figure 11).
- If installing the Optional Blower Kit the unit must be grounded to the mobile home.

Combustion Air

Combustion air can be supplied to the stove in one of two ways. Consult your local building code or CAN/CSA-B365, or NFPA 211

Pedestal Model

1. Direct outside air supply - (Necessary for mobile home installation, optional for residential installation.)
 - To draw outside air through the floor; leave the knockout or square cover plate in the rear of the pedestal in place. Use an approved 4"(100mm) inlet vent cap. Cut or drill a 4"(102mm) diameter or larger hole in the floor anywhere inside the perimeter of the pedestal base. Cover the hole with a 20GA wire mesh minimum, rodent screen and staple/nail in place. This hole must get its air from a ventilated crawl space or be extended with duct to the outdoors (see Figure 12 on page 17 or Figure 13 on page 18)
 - To draw air from behind the stove. Cut or drill a corresponding hole in the closest exterior wall. Install an approved 4"(102mm) inlet vent cap. Attach the outside air adapter (11100005) to the back of the pedestal. Connect the adapter to the inlet vent cap using 4"(100mm) flexible or rigid metal venting. . Provide water protection as required.
2. Room air supply - Remove the knockout or cover plate from the rear of the pedestal enclosure. The stove will now draw its air from the room through this opening and into the firebox intake

Leg Model

1. Direct outside air supply - (Necessary for mobile home installation, optional for residential installation.)
 - To draw outside air through the floor; Cut or drill a 4"(102mm) diameter or larger hole in the floor under the stove. Attach the outside air adapter (11100005) to the underside of the stove. Connect the adapter to the hole using 4"(102mm) flexible or rigid metal venting. Cover the hole with a 20GA wire mesh minimum, rodent screen and staple/nail in place. This hole must get its air from a ventilated crawl space or be extended with duct to the outdoors (see Figure 12 on page 17 or Figure 13 on page 18. if extended use an approved 4"(102mm) inlet vent cap
 - To draw air from behind the stove. Cut or drill a corresponding hole in the closest exterior wall. Install an approved 4"(102mm) inlet vent cap. Attach the outside air adapter (11100005) to the underside of the stove. Connect the adapter to the inlet vent cap using 4"(102mm) flexible or rigid metal venting. Provide water protection as required.
2. Room air supply - The stove will draw its air from the room through the opening in the bottom

Note:

The use of outside combustion air for installation requires the unit to be secured to the structure to prevent dislodging of the air duct. (See: Securing Bracket Installation page 15)

In Canada, the use of outside combustion air for installation requires the use of an air intake damper with indicator of damper position. This damper must be 100% open when using your wood stove.

The damper must:

- Allow 100% closure
- Prevent material from dropping into any area beneath the structure
- Permit zero clearance to combustible construction and
- Weather hoods shall not permit line of sight access to the intake opening

The living space around the heater must be well ventilated with good air circulation. Anything that may cause a negative pressure can cause gases or fumes to be pulled into the living area. During extremely cold weather, and especially when burning at very slow rates, the upper parts of the exposed chimney may ice up, partially blocking the flue gases. If blockage occurs, flue gases may enter living space.

This unit is **not** designed to be operated with the firing door open. In addition to the obvious hazard of sparks landing on combustibles, an open fire door will cause the heater to draw air from the living space and possibly cause suffocation in an air tight home.

Baffle Board / Tube Installation

The Chimney connector pipe should be disconnected from the wood stove to clean and inspect the chimney. Only if this is not possible should you remove Baffle Board.

DO NOT OPERATE WITH BAFFLE BOARD INSULATION OR TUBES REMOVED.

Removal

1. Lift the baffle board and bend the retaining clip on the right side of the front baffle tube up then disengage the tab from the hole in the tube.
2. Slide the tube to the right to disengage the left end of the tube from the baffle air box and remove the tube from the unit. Repeat the first two steps with the remaining baffle tubes.
3. Grasp the front edge of the left half of the baffle board and tilt up at the back. Guide the board down and through the door opening.
4. Grasp the right half of the baffle board and slide it over to the left and tilt the back of the board up and guide it down and through the door opening.
5. Reverse the process to replace the baffle assembly.

Installation

1. Insert one half of baffle board above the two back baffle tubes inside the firebox, slide over to the right and allow to rest on the baffle air assembly.
2. Ensure that the second half is inserted to allow the two cuts in the baffle boards to overlap. Insert the other half of the baffle board and allow to rest on the left side baffle air assembly.
3. With the holes facing forward and the notch to the left side, insert a baffle tube into the hole in the baffle air channel on the right at an angle and then raise and insert into the opposite hole on the left side baffle air assembly until the tube sits tight to the tab in the hole.
4. Place the retaining clip tab into the hole in the baffle tube on the right side and bend it back over the tube to secure it in place.
5. Repeat steps #3 & #4 with the remaining baffle tube.
6. Slide the baffle board halves together and then separate slightly to ensure there are no gaps on either side of the baffle board.
7. Push baffle board tight against the rear of the firebox.

Motor Control Removal & Installation

There are two Motor Control Assemblies located underneath the unit at the back. The Motor Control Assemblies are named #1(Left) and #2(Right) if standing and facing the back of the unit.

1. Remove the motor cover by undoing the three screws located at the sides and in the back. Figure 15
2. Remove the Control Board Cover from the Control Board Assembly located to the left of the Motor Control Assemblies by undoing the single screw on the left side of the Control Board Assembly. Figure 16
3. Unplug the wires for the Motor Control Assembly that you are removing from the Control Board. Figure 18
4. Remove the two screws securing the Motor Control Assembly to the Control box and lower the Motor Control Assembly being careful not to damage the gasket(part #80002849). Figure 17
5. Reverse the previous steps to reinstall the new Motor Control Assembly.

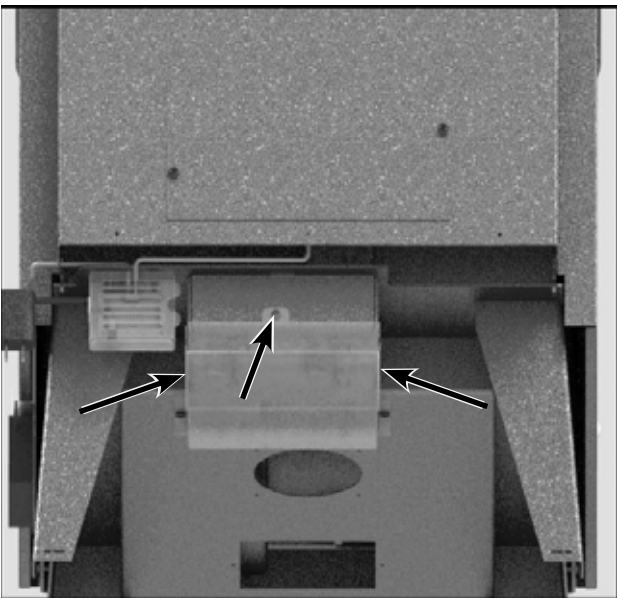

Figure 15: Motor Control cover.

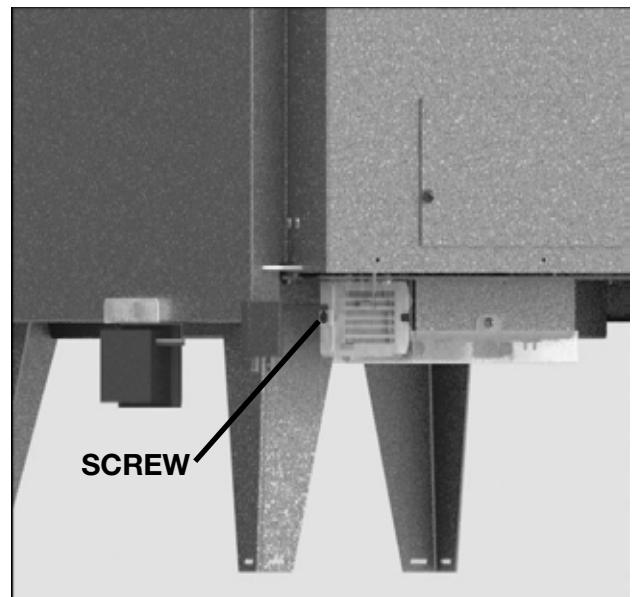

Figure 16: Control Board cover

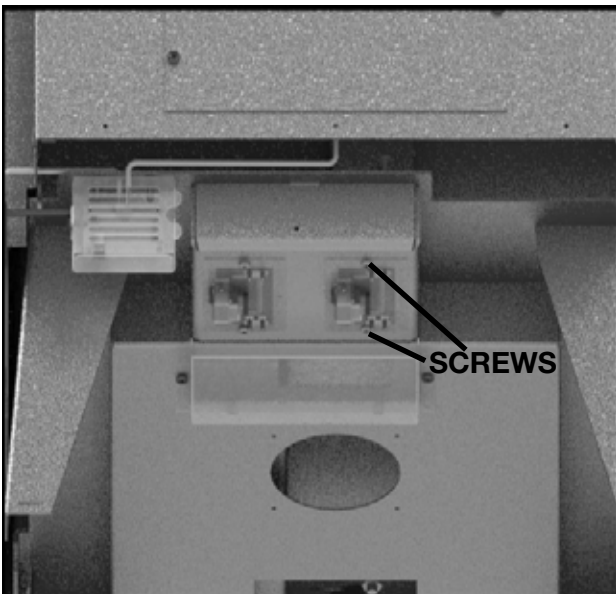

Figure 17: Motor Control assemblies

Control Board Removal & Installation

The Control Board Assembly is located to the left of the Motor Control Assembly, underneath the unit at the back.

1. Remove the Control Board Cover from the Control Board Assembly by undoing the single screw on the left side of the Control Board Assembly. Figure 16
2. Unplug the wires from the Motor Control Assemblies, located on the right edge of the Control Board. Note the placement for connecting the wires when installing the new Control Board Assembly. Figure 18
3. Using a small screwdriver, loosen the screws securing the Flue Thermocouple wires to the socket near the top of the Control Board. Then separate the connector for the Firebox Thermocouple just above the Control Board. Note the placement for connecting the wires when installing the new Control Board Assembly. Figure 18
4. Unplug the wires from the Battery Box, located on the left side of the Control Board. Note the placement for connecting the wires when installing the new Control Board Assembly. Figure 18
5. Unplug the wires from the Power Adapter, located on the side of the Control Board. Note the placement for connecting the wires when installing the new Control Board Assembly. Figure 18
6. Remove the two nuts and bolts at the top of the Control Board Assembly securing the assembly to the unit. Figure 18
7. Reverse step 1-6 to reinstall the new Control Board Assembly.

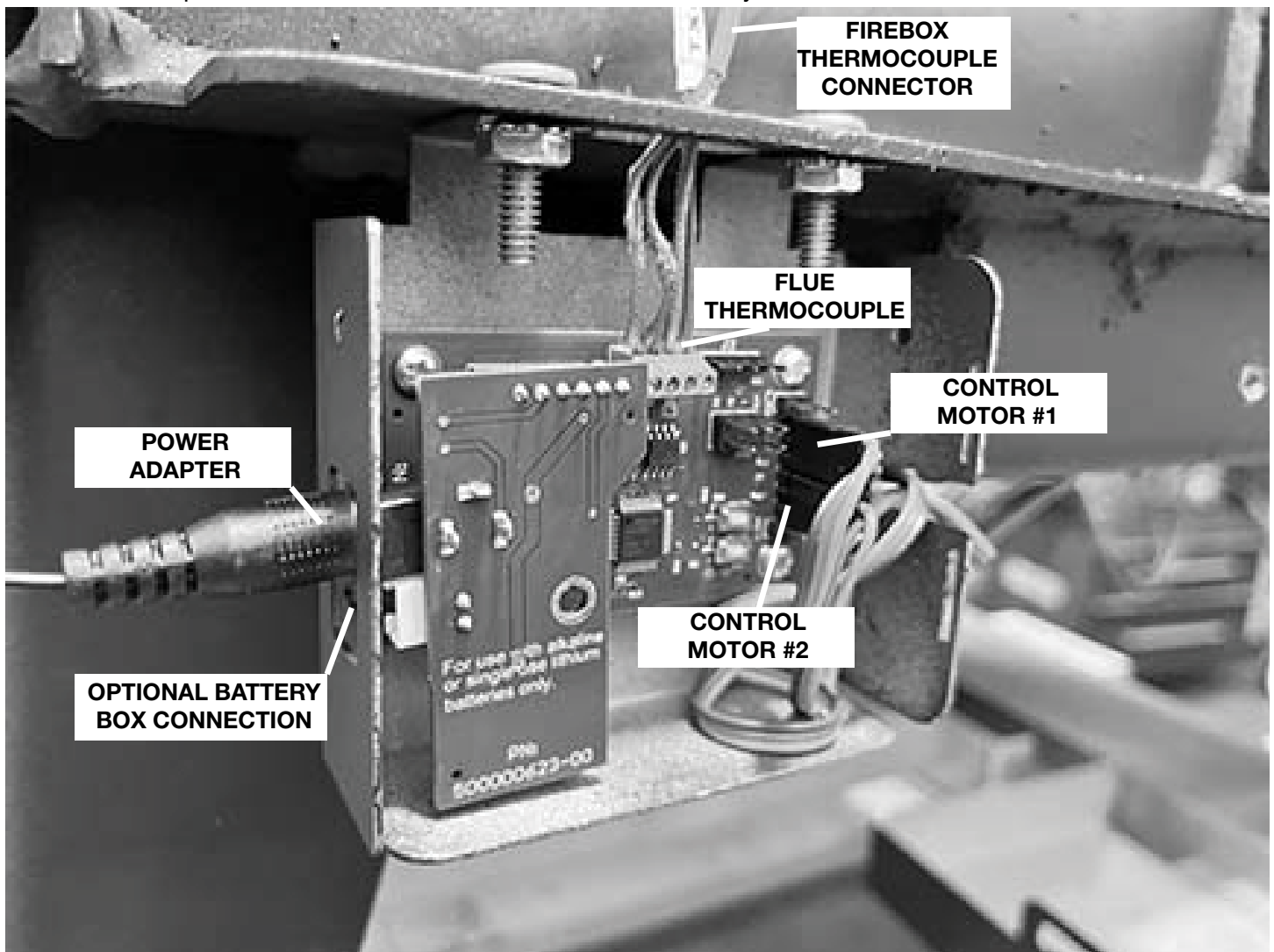

Figure 18: Control Board with connections.

— Optional Battery Box Installation & Changing Batteries —

Battery Box Installation

1. Remove the Battery Box from the packaging.
2. Remove the Control Board Cover from the Control Board Assembly by undoing the single screw on the left side of the Control Board Assembly. (The Control Board Assembly is located to the left of the Motor Control Assembly, underneath the unit at the back.)
3. Connect the plug from the Battery Box to the connection on the left side of the Control Board. See "Figure 18" on page 25 (Left side is "your left" and determined when standing facing the back of the unit.)
4. Engage the magnet on the Battery Box Assembly under the right, side panel and against the right, firebox side. Figure 19 (Right is "your right" and determined when standing facing the front of the unit.)

Changing the Batteries

The Battery Box Assembly is located on the right side of the unit, below the side panel, if standing, facing the front of the unit. The Battery Box Assembly is secured to the firebox with a magnet and can be easily lowered and held to change the batteries. **Note: Be careful not to pull on the wires connecting the Battery Box to the Control Board.**

1. Carefully lower the Battery Box so the battery cover is facing up.
2. Remove the battery cover by releasing the catch at the end and lifting the cover off.
3. Remove the old batteries and replace them with the new ones.
4. Replace the battery cover and re-engage the magnet to the firebox side again.

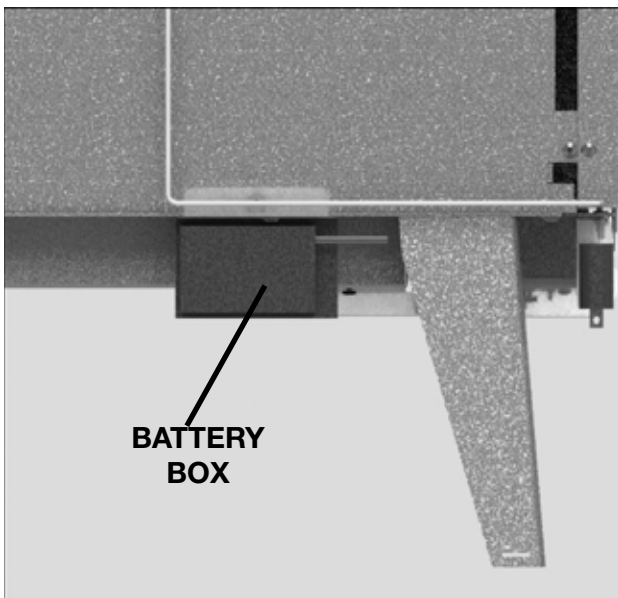

Figure 19: Battery Box

Thermocouple Replacement

The unit has two thermocouples, one located in the Flue and the other is located in the right side of the fire-box behind the right side panel. ("right side" is your right and determined when standing facing the front of the unit.)

Flue Thermocouple

1. Remove the rear shield air deflector by undoing the three screws securing it to the rear shield.
2. Bend the securing tab on the thermocouple mounting bracket up approximately 45°.
3. Rotate the thermocouple clock-wise to disengage it from the mounting bracket then pull it out of the flue collar.
4. Remove the Control Board Cover from the Control Board Assembly by undoing the single screw on the left side of the Control Board Assembly. See "Figure 16" on page 24 (The Control Board Assembly is located to the left of the Motor Control Assembly, underneath the unit at the back.)
5. Using a small screwdriver, loosen the screws securing the Thermocouple wires to the socket near the top of the Control Board. See "Figure 18" on page 25. Note the placement for connecting the wires when installing the new Control Board Assembly.
6. Reverse steps 1-5 to reinstall the new Thermocouple.

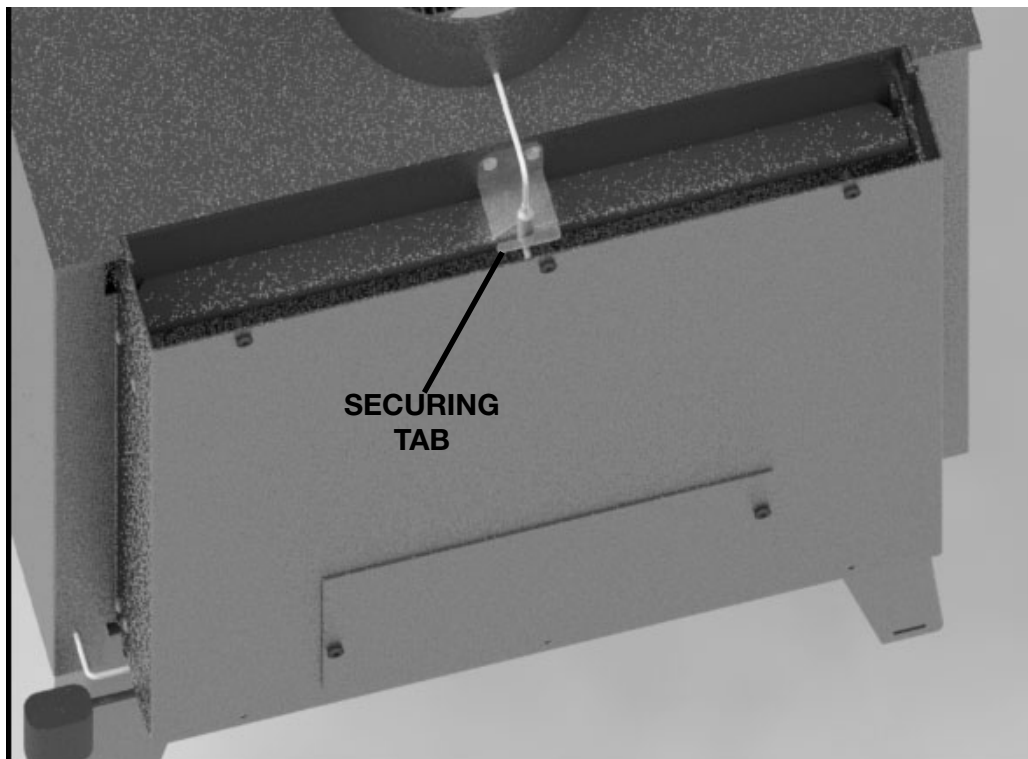

Figure 20: Flue Thermocouple

Firebox Thermocouple

1. Remove the right side panel by undoing the two screws in the back edge of the panel and disengaging the panel from the bolts in the front. ("right side" is your right and determined when standing facing the front of the unit.)
2. Bend the securing tab on the thermocouple mounting bracket up approximately 45°. Figure 21
3. Rotate the thermocouple clock-wise to disengage it from the mounting bracket then pull it out of the firebox side. Figure 21
4. Remove the Control Board Cover from the Control Board Assembly by undoing the single screw on the left side of the Control Board Assembly. (The Control Board Assembly is located to the left of the Motor Control Assembly, underneath the unit at the back.) See "Figure 16" on page 24
5. Separate the connector for the Firebox Thermocouple just above the Control Board. See "Figure 18" on page 25.
6. Reverse steps 1-5 to reinstall the new Thermocouple.

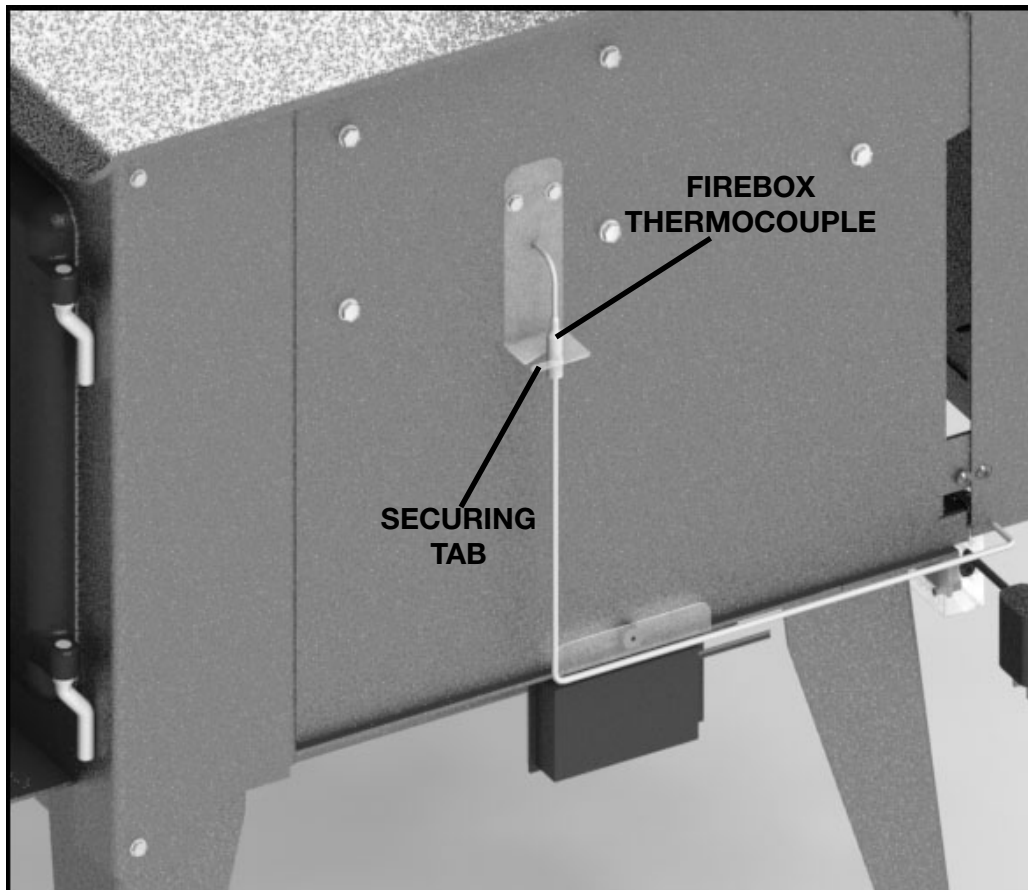

Figure 21: Firebox Thermocouple

Catalyst Monitoring



WARNING

DO NOT USE THIS APPLIANCE WITHOUT A COMBUSTOR

WARNING: “This wood heater contains a catalytic combustor, which needs periodic inspection and replacement for proper operation. It is against federal regulations to operate this wood heater in a manner inconsistent with operating instructions in this manual, or if the catalytic element is deactivated or removed.”

It is important to periodically monitor the operation of the catalytic combustor to ensure that it is functioning properly. A non-functioning combustor will result in a loss of heating efficiency, and an increase in creosote and emissions. Following is a list of items that should be checked on a periodic basis:

- Combustors should be visually inspected at least three times during the heating season to determine if physical degradation has occurred. Actual removal of the combustor is not recommended unless more detailed inspection is warranted because of decreased performance.

CATALYTIC COMBUSTOR, CLEANING

Under certain conditions, ash particles may become attached to the face of the combustor. These may be seen when the fire is out. Any deposit on the visible face of the combustor should be removed. Wait until the fire is out and the appliance is cold before performing any cleaning.

Brushing the combustor with a soft bristle paint brush will remove some deposits. Passing a vacuum cleaner wand or brush near the face of the combustor will remove most deposits. (Hot ash in a vacuum cleaner bag will burn, may melt the vacuum or cause a house fire. Exercise caution and never clean the appliance when the appliance or ashes are hot.)

Never scrape the combustor with any hard tool or brush. Never run pipe cleaner through the individual cells of the combustor. This is not needed, and may do more harm than good. Limit cleaning to the face of the combustor.

TIP: A hot fire will usually prove to be the best method of cleaning the combustor of deposits

CATALYTIC COMBUSTOR, TROUBLESHOOTING

NORMAL CATALYTIC COMBUSTOR CONDITION

The catalytic combustor should come packaged inside the unit and should appear as shown here when new.



PROBLEM - CREOSOTE PLUGGING

Possible Cause: Burning materials that produce a lot of char and fly-ash

Solution: Do not burn materials such as garbage, gift wrap, or cardboard.

Possible Cause: Burning wet, pitchy woods or burning large loads of small diameter wood with the combustor in place without the thermocouple in the active zone. Solution: Burn dry, seasoned wood.

Possible Cause: Combustor not functioning. If proper burning procedures have been followed to no avail, the combustor is not functioning.

Solution: Replace the combustor with a new combustor from the manufacturer.

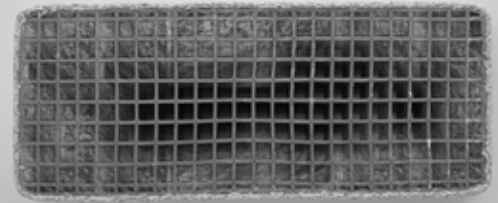

CREOSOTE PLUGGING

PROBLEM - CATALYST MASKING

(The catalyst is coated with a layer of fly-ash or soot which prevents catalytic activity)

Possible Cause: Accumulation of fly-ash

Solution: Brush cooled combustor with a soft-bristled brush or vacuum lightly at least once per burning season.



FLY ASH
MASKING

PROBLEM - MECHANICAL & THERMAL CRACKING

Possible Cause: Mishandling, abuse.

Solution: Handle with care

Possible Cause: Distortion of holding bracket.

Solution: Combustor should be held firmly in its place. It should slide easily into and out of the holding bracket of the stove. If severe cracking has resulted in loss of large chunks of combustor, replace combustor. Also replace any warped stove parts.

Possible Cause: Normal operation, as long as the combustor remains intact.

Solution: If cracking causes large pieces to fall out, replace the combustor.



SOOT MASKING

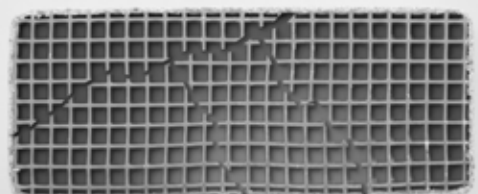

MECHANICAL & THERMAL
CRACKING

This appliance comes equipped with a Combustor Monitor to maintain the fire in the most efficient manner tailored to your specific needs and installation configuration.

Catalyst Removal & Installation

DO NOT OPERATE WITH BAFFLE BOARD INSULATION , CATALYST OR TUBES REMOVED.

Removal

1. Lift the baffle board and bend the retaining clip on the right side of the front baffle tube up then disengage the tab from the hole in the tube.
2. Slide the tube to the right to disengage the left end of the tube from the baffle airbox and remove the tube from the unit. Repeat the first two steps with the second baffle tube.
3. Grasp the front edge of the left half of the baffle board and tilt up at the back. Guide the board down and through the door opening.
4. Grasp the right half of the baffle board and slide it over to the left and tilt the back of the board up and guide it down and through the door opening.
5. Reach up then push the combustor up and out of the holding platform until it is against the firebox top.
6. Slide the combustor towards the back of the unit and drop it down to remove it.
7. Reverse these steps to reinstall the combustor, the baffle boards and baffle tubes.

Optional Blower

The optional blower kit (#31140001) is equipped with a three prong power cord and may be installed at any time. Route power supply cord away from heater.

Electrical rating: 115V, 60Hz, 0.5 amps.

Blower Installation

1. Remove the two screws and cover plate from the rear shield on the stove (Figure 23).
2. Place the blower into the opening in the rear shield with the blower outlet pointing up (Figure 24). Attach by using the screws provided with the Blower Kit,
3. Tighten the screws.

Blower Operation

Proper blower speed matched with air control setting will ensure peak performance from your stove. Operate as follows:

- Except on "High" setting, wait 30 minutes before turning on blower to desired setting.

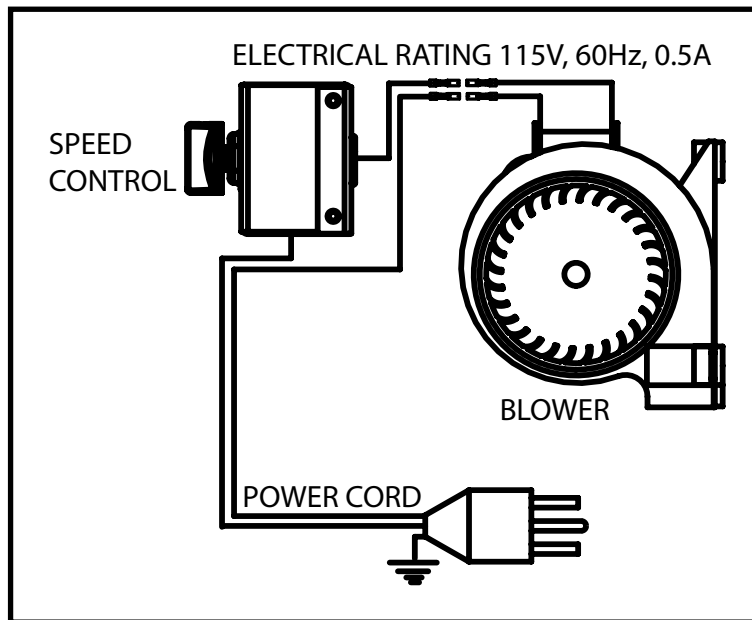

Figure 22: Blower Wiring Diagram.

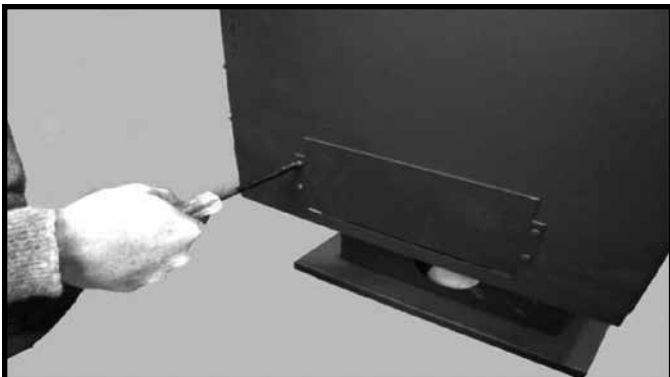

Figure 23: Remove the cover plate.

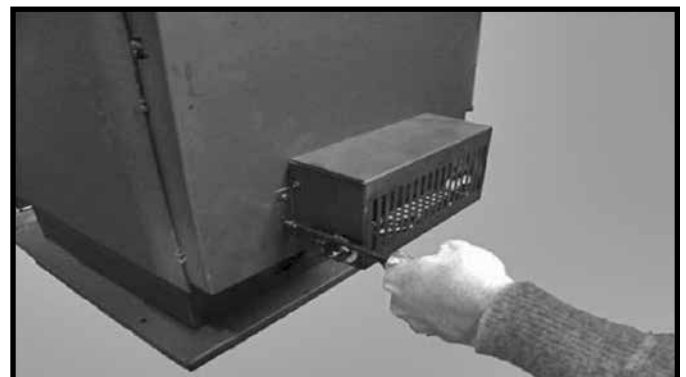

Figure 24: Installing the blower.

Electrical Supply

For your protection against shock hazard, use only a properly grounded outlet that will accept a three-pronged plug. Do not cut or remove the grounding prong. Do not route power cord under unit. Power cord must be routed to avoid contact with any hot or sharp surfaces.

Consult local codes or, in the absence of local codes, with the current CSA C22.2 Canadian Electrical Code and in the USA with the National Electrical Code, ANSI/NFPA 70 (latest edition).

Firebrick Installation

The package contains 20 full-size firebricks. With the insert in its final position, install the firebricks as follows:

1. Place the first brick up under the rear brick rail (Figure 25) and slide it to either the far left or far right.
2. Place 3 more bricks up under the rear brick rail to complete the rear brick placement (Figure 26).

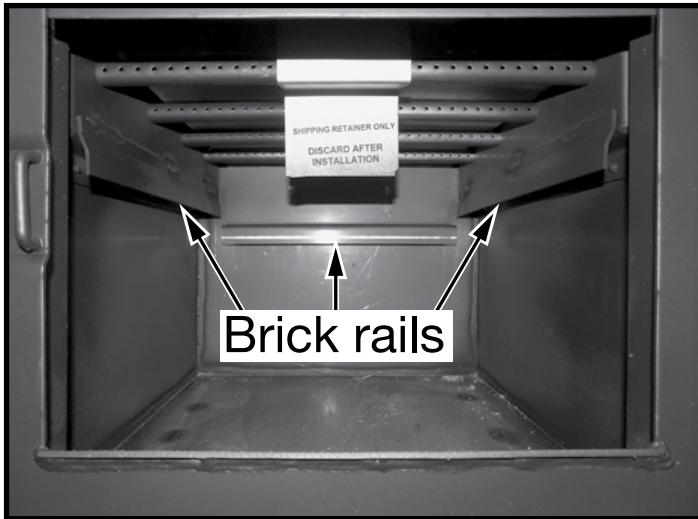

Figure 25: Firebox and brick rails.



Figure 26: Bricks against rear wall.

3. Place the floor bricks as shown in Figure 27.
4. On both the right and left sides, place the first side wall brick under the Brick Retainer and on top of the floor bricks and slide it all the way to the back, so that it is up against the rear wall bricks.
5. Using the same method, place three more bricks along one of the side walls. Figure 28
- 6.
7. Repeat the side wall brick installation on the opposite side to complete the firebrick installation.

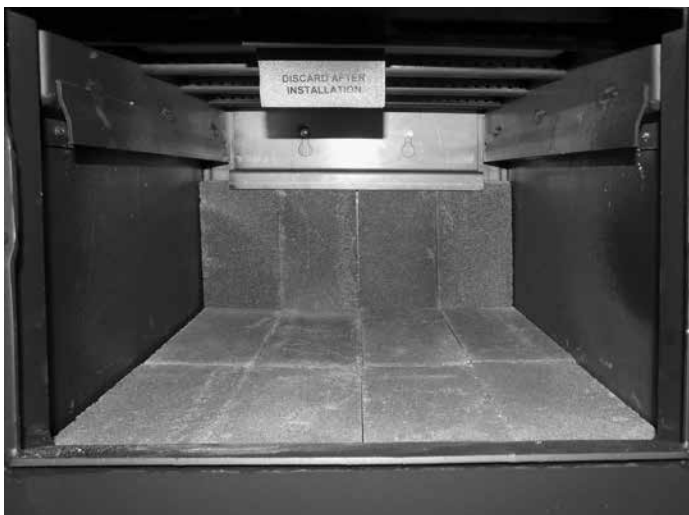

Figure 27: Floor bricks laying lengthwise.

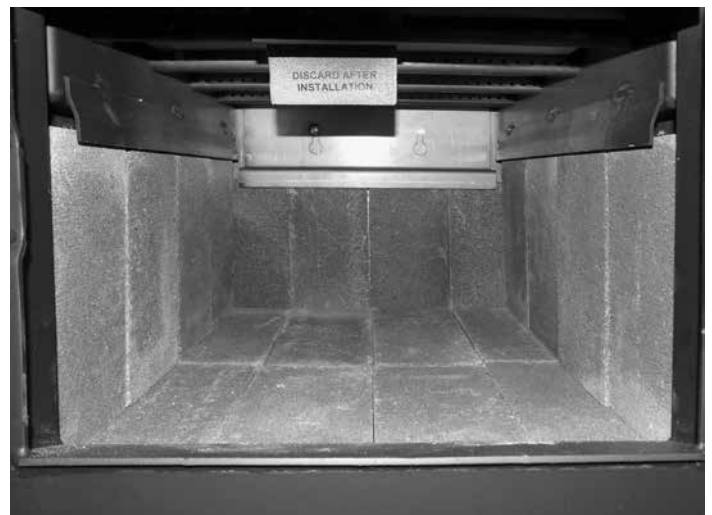

Figure 28: Remaining side wall bricks installation.

Troubleshooting

Problem	Cause	Cure
Glass is Dirty	1. Wood is wet 2. Turning down air control or damper too soon 3. Draft too low 4. Door gasket leakage	- Use dry wood - Do not turn down until a) there is a good bed of coals b) the wood is charred - Improper chimney height and / or diameter - Chimney plugged or restricted, check flue - Provide outside air for combustion - Replace gasket - Check latch
Excessive Creosote Buildup - See 1, 2, 3, above.		
Low Heat Output	1. Wood is wet 2. Fire too small 3. Draft too low	- Use dry wood - Build a larger fire - Chimney plugged or restricted, inspect and clean
Won't Burn Overnight	1. Air control is set too high 2. Not enough wood 3. Draft too high	- Set control lower - Unsplit wood is preferred for overnight burns - Excessive chimney height and/or diameter, See "Proper Draft" on page 10.
Stove Won't Burn	1. Combustion air supply blocked 2. Draft too low	- Check outside air supply for obstruction - Check that room air cover is removed - Chimney plugged or restricted, inspect and clean - Chimney oversized or otherwise unsuitable, Consult Dealer

Replacement Parts

(WHEN ORDERING, INCLUDE PART NUMBER WITH DESCRIPTION)

ITEM	DESCRIPTION	PART NO.
1	Baffle Board (2pcs.).....	80000619
2	Baffle Tube Set (4pcs.)	80000615
3a	Baffle Air Box, Left (c/w gasket/screws)	80002140
3b	Baffle Air Box, Right (c/w gasket/screws)	80002141
3c	Baffle Air Box, Gasket with Screws (1 side).....	80002138
4	Rear Brick Rail.....	80002143
5	Door Casting Assy - No Glass (c/w Handle)	80000621
6	Door and Glass Gasket	80000600
7	Replacement Glass (c/w clamps/gasket).....	80000616
8	4 pc Glass Clamp set (c/w screws)	80000617
9	Firebrick Set 9" x 4 1/2" x 1 1/4" (20 pcs.).....	80000620
10	Flame Shield (c/w hardware).....	80002831
11	Optional Fan	31140001
11a	Blower	80000905
11b	Fan Speed Control	80000908
11c	Speed Control Knob.....	80001509
12	Firebox Thermocouple	80002836
13	Optional Battery Box assembly.....	31490001
14	Control Board assembly.....	80002835
15	Motor Control assemblies	80002834
16	Flue Thermocouple	80002837
17	Flue Protector.....	80002832
18	Wall Adapter 12V.....	80002838
19	Catalytic Combustor(not shown).....	80002848

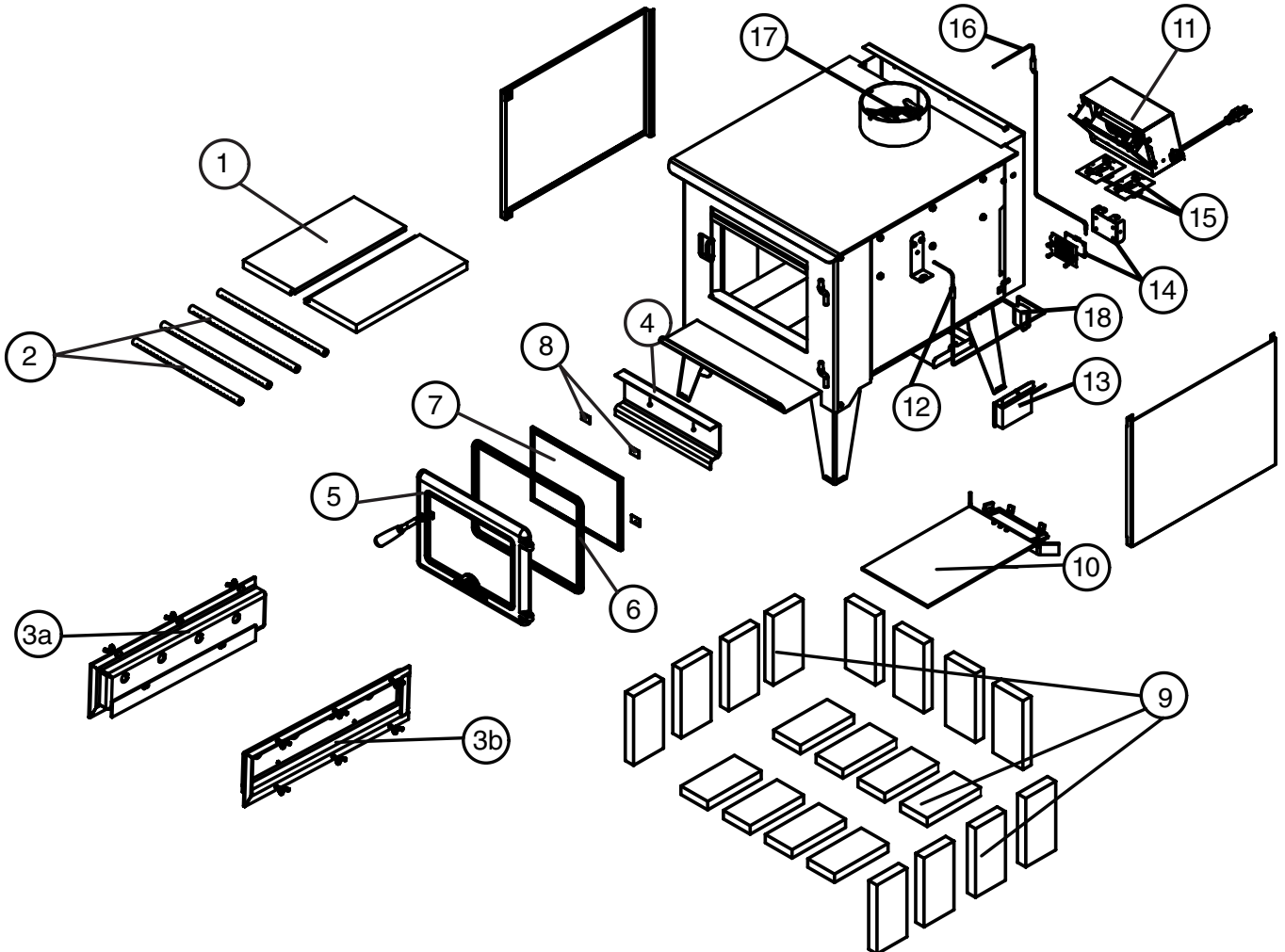

Rating Label

Rating label location

The Rating label is located on the lower portion of the rear cover.

CERTIFIED FOR CANADA AND U.S.A. - MODEL / MODELE: TN25 C
LISTED ROOM HEATER, SOLID FUEL TYPE.
ALSO FOR USE IN MOBILE HOMES
CERTIFIED TO/ CERTIFIÉ POUR : CAN/ULC-S627 and UL 1482

ETL
 ETL-4001-597
INTERNATIONAL CERTIFICATION CORPORATION

INSTALL AND USE IN ACCORDANCE WITH THE MANUFACTURER'S INSTALLATION AND OPERATING INSTRUCTIONS.
 CONTACT LOCAL BUILDING OR FIRE OFFICIALS ABOUT RESTRICTIONS, INSTALLATION PERMIT AND LISTED LOCAL BUILDING CODES.
 DO NOT CONNECT THIS UNIT TO A CHIMNEY FLUE SERVING ANOTHER APPLIANCE.
 CAN BE CONNECTED TO A LISTED MASONRY CHIMNEY SUITABLE FOR USE WITH SOLID FUELS.
 SEE LOCAL BUILDING CODE AND MANUFACTURER'S INSTRUCTIONS FOR PRECAUTIONS REQUIRED WHEN PASSING A CHIMNEY THROUGH A COMBUSTIBLE WALL OR CEILING.
 DO NOT PASS A CHIMNEY THROUGH A COMBUSTIBLE WALL OR CEILING.
 MINIMUM CLEARANCE BETWEEN CHIMNEY AND COMBUSTIBLE MATERIALS:
 ALL 18" (45.7 CM) CLEARANCE BETWEEN CHIMNEY CONNECTOR AND COMBUSTIBLE MATERIALS.
 PROTECTORS OR OTHER MEANS APPROVED BY LOCAL BUILDING OR FIRE OFFICIALS.
 CHIMNEY SYSTEM AND CONNECTOR MUST BE LISTED TO:
 IN CANADA - ULC S-641 LISTED CONNECTOR AND ULC-S-629 LISTED CHIMNEY IN U.S.A. - UL-163 HT LISTED CONNECTOR AND CHIMNEY
 USE CORNER CONNECTOR.
 OPTIONAL COMPONENT - BLOWER (TRIO BLOW) - SEE ELECTRICAL RATING: 15V, 60HZ, 5 AMP HEATER. DO NOT ROUTE POWER CORD BENEATH HEATER.
 CAUTION: RISK OF EXCESSIVE TEMPERATURES - KEEP ASH DUMP CLOSED DURING FIRING OF THE HEATER.
 KEEP FURNISHINGS AND OTHER COMBUSTIBLE MATERIALS WELL AWAY FROM HEATER.
 REPLACE GLASS ONLY WITH CERAMIC GLASS. DO NOT USE ABRASIVE CLEANERS.
 HORIZONTAL CONNECTOR NOT PERMITTED IN MOBILE HOMES.
 ALCOVE SIZE - DEPTH: 3 FT. / 91 CM MAX. HEIGHT: 7 FT. / 2.1 M MIN. WIDTH: 38 IN. / 97 CM MIN.
 COMBUSTIBLE FLOOR MUST BE PROTECTED BY A CONTINUOUS NON-COMBUSTIBLE MATERIAL EX-CEEDING THE MINIMUM CLEARANCE REQUIREMENTS.
 OTHER MATERIALS MAY CAUSE DAMAGE TO STOVE OR HOME AND MAY MAKE THE CATALYST IN THE COMBUSTOR INACTIVE.
 CONSULT THE OWNER'S MANUAL FOR FURTHER INFORMATION.
 IT IS AGAINST FEDERAL REGULATIONS TO OPERATE THIS WOOD HEATER IN A MANNER INCONSISTENT WITH THE OPERATING INSTRUCTIONS IN THE OWNER'S MANUAL.
HOT WHILE IN OPERATION. DO NOT TOUCH. KEEP CHILDREN, CLOTHING AND FURNITURE AWAY. CONTACT MAY CAUSE SKIN BURNS. SEE NAMEPLATE AND INSTRUCTIONS. / CHAUD LORSQU'EN OPERATION. NE PAS TOUCHER. TENEZ LES ENFANTS ET LES VÊTEMENTS BIEN À L'ÉCART. LE CONTACT PEUT CAUSER DES BRÛLURES À LA PEAU. CONSULTEZ LA PLAQUE DE CONSTRUCTEUR ET LES INSTRUCTIONS.

MINIMUM CLEARANCES TO COMBUSTIBLE MATERIALS/ DÉGAGEMENTS MINIMAUX AUX MATÉRIEAUX COMBUSTIBLES

RESIDENTIAL INSTALLATION / USING SINGLE WALL CONNECTOR / INSTALLATION À UN BRAS / RACCORDEMENT DE MUR SIMPLE	RESIDENTIAL CLOSE CLEARANCE INSTALLATION / USING DOUBLE WALL CONNECTOR / INSTALLATION À DEUX BRAS / RACCORDEMENT DE MUR DOUBLE
A. 16 IN. / 405 MM	A. 16 IN. / 405 MM
B. 9 1/2 IN. / 240 MM	B. 9 1/2 IN. / 240 MM
C. 9 1/2 IN. / 240 MM	C. 9 1/2 IN. / 240 MM
D. 14 1/2 IN. / 368 MM	D. 14 1/2 IN. / 368 MM
E. 14 1/2 IN. / 368 MM	E. 14 1/2 IN. / 368 MM
F. 17 1/2 IN. / 443 MM	F. 17 1/2 IN. / 443 MM

RESIDENTIAL SIDE WALL CLEARANCE INSTALLATION / USING DOUBLE WALL CONNECTOR / INSTALLATION À DEUX BRAS / RACCORDEMENT DE MUR DOUBLE

RESIDENTIAL SIDE WALL CLEARANCE INSTALLATION / USING DOUBLE WALL CONNECTOR / INSTALLATION À DEUX BRAS / RACCORDEMENT DE MUR DOUBLE	MOBILE HOME INSTALLATION / USING DOUBLE WALL CONNECTOR / INSTALLATION À DEUX BRAS / RACCORDEMENT DE MUR DOUBLE
A. 16 IN. / 405 MM	A. 16 IN. / 405 MM
B. 6 1/2 IN. / 165 MM	B. 6 1/2 IN. / 165 MM
C. 23 1/2 IN. / 593 MM	C. 23 1/2 IN. / 593 MM
D. 11 IN. / 280 MM	D. 11 IN. / 280 MM
E. 11 IN. / 280 MM	E. 11 IN. / 280 MM
F. 15 IN. / 380 MM	F. 15 IN. / 380 MM

MINIMUM CLEARANCES TO COMBUSTIBLE MATERIALS/ DÉGAGEMENTS MINIMAUX AUX MATÉRIEAUX COMBUSTIBLES

RESIDENTIAL INSTALLATION / USING SINGLE WALL CONNECTOR / INSTALLATION À UN BRAS / RACCORDEMENT DE MUR SIMPLE	MOBILE HOME INSTALLATION / USING DOUBLE WALL CONNECTOR / INSTALLATION À DEUX BRAS / RACCORDEMENT DE MUR DOUBLE
A. 16 IN. / 405 MM	A. 16 IN. / 405 MM
B. 6 1/2 IN. / 165 MM	B. 6 1/2 IN. / 165 MM
C. 23 1/2 IN. / 593 MM	C. 23 1/2 IN. / 593 MM
D. 11 IN. / 280 MM	D. 11 IN. / 280 MM
E. 11 IN. / 280 MM	E. 11 IN. / 280 MM
F. 15 IN. / 380 MM	F. 15 IN. / 380 MM

IN CANADA / AU CANADA

IN CANADA / AU CANADA	IN U.S.A.
A. 16 IN. / 405 MM	A. 16 INCHES / 405 MM
B. 6 1/2 IN. / 165 MM	B. 6 1/2 INCHES / 165 MM
C. 23 1/2 IN. / 593 MM	C. 23 1/2 INCHES / 593 MM
D. 11 IN. / 280 MM	D. 11 INCHES / 280 MM
E. 11 IN. / 280 MM	E. 11 INCHES / 280 MM
F. 15 IN. / 380 MM	F. 15 INCHES / 380 MM

MINIMUM CLEARANCES TO COMBUSTIBLE MATERIALS/ DÉGAGEMENTS MINIMAUX AUX MATÉRIEAUX COMBUSTIBLES

IN CANADA / AU CANADA	IN U.S.A.
A. 16 IN. / 405 MM	A. 16 INCHES / 405 MM
B. 6 1/2 IN. / 165 MM	B. 6 1/2 INCHES / 165 MM
C. 23 1/2 IN. / 593 MM	C. 23 1/2 INCHES / 593 MM
D. 11 IN. / 280 MM	D. 11 INCHES / 280 MM
E. 11 IN. / 280 MM	E. 11 INCHES / 280 MM
F. 15 IN. / 380 MM	F. 15 INCHES / 380 MM

MINIMUM CLEARANCES TO COMBUSTIBLE MATERIALS/ DÉGAGEMENTS MINIMAUX AUX MATÉRIEAUX COMBUSTIBLES

IN CANADA / AU CANADA	IN U.S.A.
A. 16 IN. / 405 MM	A. 16 INCHES / 405 MM
B. 6 1/2 IN. / 165 MM	B. 6 1/2 INCHES / 165 MM
C. 23 1/2 IN. / 593 MM	C. 23 1/2 INCHES / 593 MM
D. 11 IN. / 280 MM	D. 11 INCHES / 280 MM
E. 11 IN. / 280 MM	E. 11 INCHES / 280 MM
F. 15 IN. / 380 MM	F. 15 INCHES / 380 MM

MINIMUM CLEARANCES TO COMBUSTIBLE MATERIALS/ DÉGAGEMENTS MINIMAUX AUX MATÉRIEAUX COMBUSTIBLES

IN CANADA / AU CANADA	IN U.S.A.
A. 16 IN. / 405 MM	A. 16 INCHES / 405 MM
B. 6 1/2 IN. / 165 MM	B. 6 1/2 INCHES / 165 MM
C. 23 1/2 IN. / 593 MM	C. 23 1/2 INCHES / 593 MM
D. 11 IN. / 280 MM	D. 11 INCHES / 280 MM
E. 11 IN. / 280 MM	E. 11 INCHES / 280 MM
F. 15 IN. / 380 MM	F. 15 INCHES / 380 MM

MINIMUM CLEARANCES TO COMBUSTIBLE MATERIALS/ DÉGAGEMENTS MINIMAUX AUX MATÉRIEAUX COMBUSTIBLES

IN CANADA / AU CANADA	IN U.S.A.
A. 16 IN. / 405 MM	A. 16 INCHES / 405 MM
B. 6 1/2 IN. / 165 MM	B. 6 1/2 INCHES / 165 MM
C. 23 1/2 IN. / 593 MM	C. 23 1/2 INCHES / 593 MM
D. 11 IN. / 280 MM	D. 11 INCHES / 280 MM
E. 11 IN. / 280 MM	E. 11 INCHES / 280 MM
F. 15 IN. / 380 MM	F. 15 INCHES / 380 MM

MINIMUM CLEARANCES TO COMBUSTIBLE MATERIALS/ DÉGAGEMENTS MINIMAUX AUX MATÉRIEAUX COMBUSTIBLES

IN CANADA / AU CANADA	IN U.S.A.
A. 16 IN. / 405 MM	A. 16 INCHES / 405 MM
B. 6 1/2 IN. / 165 MM	B. 6 1/2 INCHES / 165 MM
C. 23 1/2 IN. / 593 MM	C. 23 1/2 INCHES / 593 MM
D. 11 IN. / 280 MM	D. 11 INCHES / 280 MM
E. 11 IN. / 280 MM	E. 11 INCHES / 280 MM
F. 15 IN. / 380 MM	F. 15 INCHES / 380 MM

MINIMUM CLEARANCES TO COMBUSTIBLE MATERIALS/ DÉGAGEMENTS MINIMAUX AUX MATÉRIEAUX COMBUSTIBLES

IN CANADA / AU CANADA	IN U.S.A.
A. 16 IN. / 405 MM	A. 16 INCHES / 405 MM
B. 6 1/2 IN. / 165 MM	B. 6 1/2 INCHES / 165 MM
C. 23 1/2 IN. / 593 MM	C. 23 1/2 INCHES / 593 MM
D. 11 IN. / 280 MM	D. 11 INCHES / 280 MM
E. 11 IN. / 280 MM	E. 11 INCHES / 280 MM
F. 15 IN. / 380 MM	F. 15 INCHES / 380 MM

MINIMUM CLEARANCES TO COMBUSTIBLE MATERIALS/ DÉGAGEMENTS MINIMAUX AUX MATÉRIEAUX COMBUSTIBLES

IN CANADA / AU CANADA	IN U.S.A.
A. 16 IN. / 405 MM	A. 16 INCHES / 405 MM
B. 6 1/2 IN. / 165 MM	B. 6 1/2 INCHES / 165 MM
C. 23 1/2 IN. / 593 MM	C. 23 1/2 INCHES / 593 MM
D. 11 IN. / 280 MM	D. 11 INCHES / 280 MM
E. 11 IN. / 280 MM	E. 11 INCHES / 280 MM
F. 15 IN. / 380 MM	F. 15 INCHES / 380 MM

MINIMUM CLEARANCES TO COMBUSTIBLE MATERIALS/ DÉGAGEMENTS MINIMAUX AUX MATÉRIEAUX COMBUSTIBLES

IN CANADA / AU CANADA	IN U.S.A.
A. 16 IN. / 405 MM	A. 16 INCHES / 405 MM
B. 6 1/2 IN. / 165 MM	B. 6 1/2 INCHES / 165 MM
C. 23 1/2 IN. / 593 MM	C. 23 1/2 INCHES / 593 MM
D. 11 IN. / 280 MM	D. 11 INCHES / 280 MM
E. 11 IN. / 280 MM	E. 11 INCHES / 280 MM
F. 15 IN. / 380 MM	F. 15 INCHES / 380 MM

MINIMUM CLEARANCES TO COMBUSTIBLE MATERIALS/ DÉGAGEMENTS MINIMAUX AUX MATÉRIEAUX COMBUSTIBLES

IN CANADA / AU CANADA	IN U.S.A.
A. 16 IN. / 405 MM	A. 16 INCHES / 405 MM
B. 6 1/2 IN. / 165 MM	B. 6 1/2 INCHES / 165 MM
C. 23 1/2 IN. / 593 MM	C. 23 1/2 INCHES / 593 MM
D. 11 IN. / 280 MM	D. 11 INCHES / 280 MM
E. 11 IN. / 280 MM	E. 11 INCHES / 280 MM
F. 15 IN. / 380 MM	F. 15 INCHES / 380 MM

MINIMUM CLEARANCES TO COMBUSTIBLE MATERIALS/ DÉGAGEMENTS MINIMAUX AUX MATÉRIEAUX COMBUSTIBLES

IN CANADA / AU CANADA	IN U.S.A.
A. 16 IN. / 405 MM	A. 16 INCHES / 405 MM
B. 6 1/2 IN. / 165 MM	B. 6 1/2 INCHES / 165 MM
C. 23 1/2 IN. / 593 MM	C. 23 1/2 INCHES / 593 MM
D. 11 IN. / 280 MM	D. 11 INCHES / 280 MM
E. 11 IN. / 280 MM	E. 11 INCHES / 280 MM
F. 15 IN. / 380 MM	F. 15 INCHES / 380 MM

MINIMUM CLEARANCES TO COMBUSTIBLE MATERIALS/ DÉGAGEMENTS MINIMAUX AUX MATÉRIEAUX COMBUSTIBLES

IN CANADA / AU CANADA	IN U.S.A.
A. 16 IN. / 405 MM	A. 16 INCHES / 405 MM
B. 6 1/2 IN. / 165 MM	B. 6 1/2 INCHES / 165 MM
C. 23 1/2 IN. / 593 MM	C. 23 1/2 INCHES / 593 MM
D. 11 IN. / 280 MM	D. 11 INCHES / 280 MM
E. 11 IN. / 280 MM	E. 11 INCHES / 280 MM
F. 15 IN. / 380 MM	F. 15 INCHES / 380 MM

MINIMUM CLEARANCES TO COMBUSTIBLE MATERIALS/ DÉGAGEMENTS MINIMAUX AUX MATÉRIEAUX COMBUSTIBLES

IN CANADA / AU CANADA	IN U.S.A.
A. 16 IN. / 405 MM	A. 16 INCHES / 405 MM
B. 6 1/2 IN. / 165 MM	B. 6 1/2 INCHES / 165 MM
C. 23 1/2 IN. / 593 MM	C. 23 1/2 INCHES / 593 MM
D. 11 IN. / 280 MM	D. 11 INCHES / 280 MM
E. 11 IN. / 280 MM	E. 11 INCHES / 280 MM
F. 15 IN. / 380 MM	F. 15 INCHES / 380 MM

MINIMUM CLEARANCES TO COMBUSTIBLE MATERIALS/ DÉGAGEMENTS MINIMAUX AUX MATÉRIEAUX COMBUSTIBLES

IN CANADA / AU CANADA	IN U.S.A.
A. 16 IN. / 405 MM	A. 16 INCHES / 405 MM
B. 6 1/2 IN. / 165 MM	B. 6 1/2 INCHES / 165 MM
C. 23 1/2 IN. / 593 MM	C. 23 1/2 INCHES / 593 MM
D. 11 IN. / 280 MM	D. 11 INCHES / 280 MM
E. 11 IN. / 280 MM	E. 11 INCHES / 280 MM
F. 15 IN. / 380 MM	F. 15 INCHES / 380 MM

MINIMUM CLEARANCES TO COMBUSTIBLE MATERIALS/ DÉGAGEMENTS MINIMAUX AUX MATÉRIEAUX COMBUSTIBLES

IN CANADA / AU CANADA	IN U.S.A.
A. 16 IN. / 405 MM	A. 16 INCHES / 405 MM
B. 6 1/2 IN. / 165 MM	B. 6 1/2 INCHES / 165 MM
C. 23 1/2 IN. / 593 MM	C. 23 1/2 INCHES / 593 MM
D. 11 IN. / 280 MM	D. 11 INCHES / 280 MM
E. 11 IN. / 280 MM	E. 11 INCHES / 280 MM
F. 15 IN. / 380 MM	F. 15 INCHES / 380 MM

MINIMUM CLEARANCES TO COMBUSTIBLE MATERIALS/ DÉGAGEMENTS MINIMAUX AUX MATÉRIEAUX COMBUSTIBLES

IN CANADA / AU CANADA	IN U.S.A.
A. 16 IN. / 405 MM	A. 16 INCHES / 405 MM
B. 6 1/2 IN. / 165 MM	B. 6 1/2 INCHES / 165 MM
C. 23 1/2 IN. / 593 MM	C. 23 1/2 INCHES / 593 MM
D. 11 IN. / 280 MM	D. 11 INCHES / 280 MM
E. 11 IN. / 280 MM	E. 11 INCHES / 280 MM
F. 15 IN. / 380 MM	F. 15 INCHES / 380 MM

MINIMUM CLEARANCES TO COMBUSTIBLE MATERIALS/ DÉGAGEMENTS MINIMAUX AUX MATÉRIEAUX COMBUSTIBLES

IN CANADA / AU CANADA	IN U.S.A.
A. 16 IN. / 405 MM	A. 16 INCHES / 405 MM
B. 6 1/2 IN. / 165 MM	B. 6 1/2 INCHES / 165 MM
C. 23 1/2 IN. / 593 MM	C. 23 1/2 INCHES / 593 MM
D. 11 IN. / 280 MM	D. 11 INCHES / 280 MM
E. 11 IN. / 280 MM	E. 11 INCHES / 280 MM
F. 15 IN. / 380 MM	F. 15 INCHES / 380 MM

MINIMUM CLEARANCES TO COMBUSTIBLE MATERIALS/ DÉGAGEMENTS MINIMAUX AUX MATÉRIEAUX COMBUSTIBLES

IN CANADA / AU CANADA	IN U.S.A.
A. 16 IN. / 405 MM	A. 16 INCHES / 405 MM
B. 6 1/2 IN. / 165 MM	B. 6 1/2 INCHES / 165 MM
C. 23 1/2 IN. / 593 MM	C. 23 1/2 INCHES / 593 MM
D. 11 IN. / 280 MM	D. 11 INCHES / 280 MM
E. 11 IN. / 280 MM	E. 11 INCHES / 280 MM
F. 15 IN. / 380 MM	F. 15 INCHES / 380 MM

MINIMUM CLEARANCES TO COMBUSTIBLE MATERIALS/ DÉGAGEMENTS MINIMAUX AUX MATÉRIEAUX COMBUSTIBLES

IN CANADA / AU CANADA	IN U.S.A.
A. 16 IN. / 405 MM	A. 16 INCHES / 405 MM
B. 6 1/2 IN. / 165 MM	B. 6 1/2 INCHES / 165 MM
C. 23 1/2 IN. / 593 MM	C. 23 1/2 INCHES / 593 MM
D. 11 IN. / 280 MM	D. 11 INCHES / 280 MM
E. 11 IN. / 280 MM	E. 11 INCHES / 280 MM
F. 15 IN. / 380 MM	F. 15 INCHES / 380 MM

MINIMUM CLEARANCES TO COMBUSTIBLE MATERIALS/ DÉGAGEMENTS MINIMAUX AUX MATÉRIEAUX COMBUSTIBLES

IN CANADA / AU CANADA	IN U.S.A.
A. 16 IN. / 405 MM	A. 16 INCHES / 405 MM
B. 6 1/2 IN. / 165 MM	B. 6 1/2 INCHES / 165 MM
C. 23 1/2 IN. / 593 MM	C. 23 1/2 INCHES / 593 MM
D. 11 IN. / 280 MM	D. 11 INCHES / 280 MM
E. 11 IN. / 280 MM	E. 11 INCHES / 280 MM
F. 15 IN. / 380 MM	F. 15 INCHES / 380 MM

MINIMUM CLEARANCES TO COMBUSTIBLE MATERIALS/ DÉGAGEMENTS MINIMAUX AUX MATÉRIEAUX COMBUSTIBLES

IN CANADA / AU CANADA	IN U.S.A.
A. 16 IN. / 405 MM	A. 16 INCHES / 405 MM
B. 6 1/2 IN. / 165 MM	B. 6 1/2 INCHES / 165 MM
C. 23 1/2 IN. / 593 MM	C. 23 1/2 INCHES / 593 MM
D. 11 IN. / 280 MM	D. 11 INCHES / 280 MM
E. 11 IN. / 280 MM	E. 11 INCHES / 280 MM
F. 15 IN. / 380 MM	F. 15 INCHES / 380 MM

MINIMUM CLEARANCES TO COMBUSTIBLE MATERIALS/ DÉGAGEMENTS MINIMAUX AUX MATÉRIEAUX COMBUSTIBLES

IN CANADA / AU CANADA	IN U.S.A.
A. 16 IN. / 405 MM	A. 16 INCHES / 405 MM
B. 6 1/2 IN. / 165 MM	B. 6 1/2 INCHES / 165 MM
C. 23 1/2 IN. / 593 MM	C. 23 1/2 INCHES / 593 MM
D. 11 IN. / 280 MM	D. 11 INCHES / 280 MM
E. 11 IN. / 280 MM	E. 11 INCHES / 280 MM
F. 15 IN. / 380 MM	F. 15 INCHES / 380 MM

MINIMUM CLEARANCES TO COMBUSTIBLE MATERIALS/ DÉGAGEMENTS MINIMAUX AUX MATÉRIEAUX COMBUSTIBLES

IN CANADA / AU CANADA	IN U.S.A.
A. 16 IN. / 405 MM	A. 16 INCHES / 405 MM
B. 6 1/2 IN. / 165 MM	B. 6 1/2 INCHES / 165 MM
C. 23 1/2 IN. / 593 MM	C. 23 1/2 INCHES / 593 MM
D. 11 IN. / 280 MM	D. 11 INCHES / 280 MM
E. 11 IN. / 280 MM	E. 11 INCHES / 280 MM
F. 15 IN. / 380 MM	F. 15 INCHES / 380 MM

MINIMUM CLEARANCES TO COMBUSTIBLE MATERIALS/ DÉGAGEMENTS MINIMAUX AUX MATÉRIEAUX COMBUSTIBLES

IN CANADA / AU CANADA	IN U.S.A.
A. 16 IN. / 405 MM	A. 16 INCHES / 405 MM
B. 6 1/2 IN. / 165 MM	B. 6 1/2 INCHES / 165 MM
C. 23 1/2 IN. / 593 MM	C. 23 1/2 INCHES / 593 MM
D. 11 IN. / 280 MM	D. 11 INCHES / 280 MM
E. 11 IN. / 280 MM	E. 11 INCHES / 280 MM
F. 15 IN. / 380 MM	F. 15 INCHES / 380 MM

MINIMUM CLEARANCES TO COMBUSTIBLE MATERIALS/ DÉGAGEMENTS MINIMAUX AUX MATÉRIEAUX COMBUSTIBLES

IN CANADA / AU CANADA	IN U.S.A.
A. 16 IN. / 405 MM	A. 16 INCHES / 405 MM
B. 6 1/2 IN. / 165 MM	B. 6 1/2 INCHES / 165 MM
C. 23 1/2 IN. / 593 MM	C. 23 1/2 INCHES / 593 MM
D. 11 IN. / 280 MM	D. 11 INCHES / 280 MM
E. 11 IN. / 280 MM	E. 11 INCHES / 280 MM
F. 15 IN. / 380 MM	F. 15 INCHES / 380 MM

MINIMUM CLEARANCES TO COMBUSTIBLE MATERIALS/ DÉGAGEMENTS MINIMAUX AUX MATÉRIEAUX COMBUSTIBLES

IN CANADA / AU CANADA	IN U.S.A.
A. 16 IN. / 405 MM	A. 16 INCHES / 405 MM
B. 6 1/2 IN. / 165 MM	B. 6 1/2 INCHES / 165 MM
C. 23 1/2 IN. / 593 MM	C. 23 1/2 INCHES / 593 MM
D. 11 IN. / 280 MM	D. 11 INCHES / 280 MM
E. 11 IN. / 280 MM	E. 11 INCHES / 280 MM
F. 15 IN. / 380 MM	F. 15 INCHES / 380 MM

MINIMUM CLEARANCES TO COMBUSTIBLE MATERIALS/ DÉGAGEMENTS MINIMAUX AUX MATÉRIEAUX COMBUSTIBLES

IN CANADA / AU CANADA	IN U.S.A.
A. 16 IN. / 405 MM	A. 16 INCHES / 405 MM
B. 6 1/2 IN. / 165 MM	B. 6 1/2 INCHES / 165 MM
C. 23 1/2 IN. / 593 MM	C. 23 1/2 INCHES / 593 MM
D. 11 IN. / 280 MM	D. 11 INCHES / 280 MM
E. 11 IN. / 280 MM	E. 11 INCHES / 280 MM
F. 15 IN. / 380 MM	F. 15 INCHES / 380 MM

© 2023 Copyright Pacific Energy Fireplace Products LTD

Reproduction, adaptation, or translation
without prior written permission is prohibited,
except as allowed under the copyright laws.



For technical support, please contact your retailer

**Web site: www.truenorthstoves.com
2975 Allenby Rd., Duncan, BC V9L 6V8**