



SWAYCONTROL





BM PRO

POWERING YOUR ADVENTURES

With over 50 years' experience in power solutions combined with manufacturing and design facilities in Melbourne, Australia, BM PRO are the leading experts in RV power management.

Inspired by the great outdoors, we have created a range of rugged, smart and reliable products to power your adventures.

Our range of battery, power and RV management and control systems gives you peace of mind when you are on the road, so that you can relax in even the most far-flung destinations, knowing you have control over your power needs.

To learn more about the BM PRO range of products, please visit our website teambmpro.com



CONTENTS

ABOUT THE SWAYCONTROL	.6
COMPATIBLE BRAKE CONTROLLERS	6
INSTALLATION INSTRUCTIONS	.7
MOUNTING LOCATION CONSIDERATIONS	7
MOUNTING	8
WIRING INSTRUCTIONS	.9
SWAYCONTROL WIRING HARNESS	9
WIRING DIAGRAM	10
STATUS LIGHT MODULE INSTALLATION	12
SWAYCONTROL SELF DIAGNOSTICS	12
FINAL BRAKE WIRING CHECK AND START UP	13
SERVICING	14
STATUS LIGHT LED INDICATORS	15
SPECIFICATIONS	16
WARRANTY TERMS AND CONDITIONS	18

MANUAL PART **038661**
REV 4.0



Designed by BM PRO, one of Australia's leading power solution experts, the BM PRO product range is proudly designed and manufactured in Melbourne, Australia, and represent a high-quality product that will provide years of service.

DISCLAIMER: BM PRO accepts no liability for any loss or damage which may occur from the improper or unsafe use of its products. Warranty is only valid if the unit has not been modified or misused by the customer.

ABOUT THE SWAYCONTROL

The BMPRO SwayControl is a proactive electronic stability control that automatically stabilises a caravan/trailer in the event of a sway. It automatically corrects caravan/trailer sway which can be caused by changing road conditions, driver error, lateral winds or a passing truck, keeping you safe on the road.

The SwayControl is mounted on the underside of the caravan/trailer chassis, wires directly to the trailer braking system and continuously monitors the trailer to detect sway. If sway is detected, the SwayControl automatically activates the caravan/trailer brakes to bring them and the vehicle under control.

The SwayControl distinguishes between safe maneuvering and dangerous trailer sway and does not require driver intervention. With independent control of left and right-hand side trailer brakes, and continual closed loop feedback, the SwayControl quickly and effectively applies the necessary braking force to the side of the caravan/trailer where it is needed to correct caravan/trailer sway.

The SwayControl features a "sleep mode" to conserve the battery. After 30 minutes of inactivity the SwayControl will shut itself off. The SwayControl "wakes up" when it receives a brake controller signal and is immediately ready to begin monitoring and controlling trailer sway.

When the SwayControl is in "sleep mode", the current draw from the battery is 35mA \pm 2%.

COMPATIBLE BRAKE CONTROLLERS

The SwayControl may be used with various integrated and aftermarket brake controllers, including brake controllers from:

- ▣ Ford
- ▣ General Motors
- ▣ Hayes
- ▣ Nissan
- ▣ Redarc
- ▣ Tekonsha
- ▣ Toyota
- ▣ Fiat
- ▣ Chrysler

Brake controllers from other companies not listed in this manual may also work with the SwayControl.

INSTALLATION INSTRUCTIONS

The SwayControl is required to be installed in the caravan/trailer by suitably qualified service personnel.

WARNING

For proper operation of the SwayControl, ensure the electric brakes are adjusted and maintained in accordance with the manufacturer's recommendations in the electric brakes owner's manual.

MOUNTING LOCATION CONSIDERATIONS

The suggested location for mounting the SwayControl is on the first trailer frame crossmember, approximately 0.3 to 3.0m behind the trailer hitching point.

The SwayControl must be mounted in the correct orientation (as indicated on the label), on either the "leading" or "trailing" edge of the crossmember. The "trailing" edge is preferred, as it provides the best protection from road debris.

WARNING

DO NOT spray high pressure water on the SwayControl. The SwayControl is a weather sealed, water resistant unit, but it is not designed to withstand direct, high pressure spray from a power washer.

To operate correctly, the SwayControl must be securely fastened using all four mounting holes hard up against the floor of a steel trailer.

Do not fasten the SwayControl to any other trailer surface that flexes or moves from wind or road vibration.

MOUNTING

It is essential the SwayControl is mounted in the correct orientation.

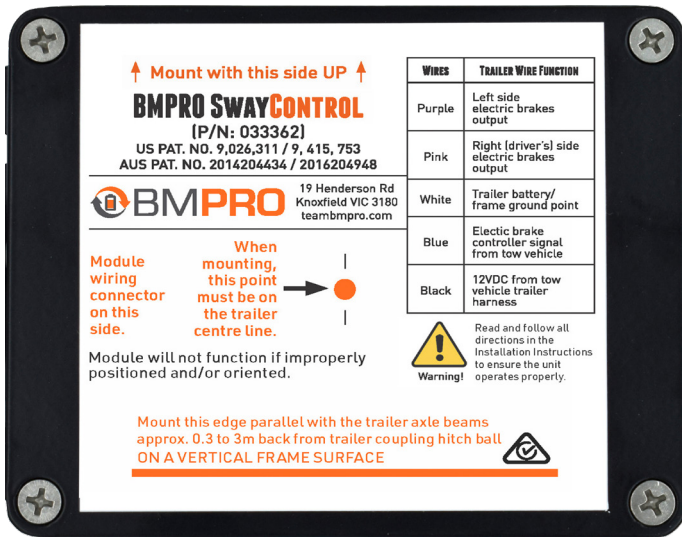

Mount the SwayControl to the caravan/trailer using the mounting flanges located on the sides of the unit. Use four 10G hex head self-drilling screws (not supplied) to mount the SwayControl.

It is recommended that starlock washers are used and that mounting screws are securely tightened to hold the SwayControl firmly in position and to avoid becoming loose from vibration.

WARNING

DO NOT drill holes in the SwayControl for any reason. Drilling holes or puncturing the unit will void your warranty.

Ensure that the SwayControl is mounted in the correct up direction.

The centre of the SwayControl (marked by the orange dot on the SwayControl label) must be positioned over the centre line of the caravan/trailer.

The bottom edge of the SwayControl (as indicated by the orange line on the bottom of the SwayControl label) must be mounted parallel to the trailer beam axle.

WIRING INSTRUCTIONS

SWAYCONTROL WIRING HARNESS

The SwayControl wire harness has five wires requiring electrical connection and one cable for the status LED light.

When making connections to the caravan/trailer's wiring harness, the desired termination is a solder joint. If the connection is not soldered, use the appropriate size and type of "crimp-type" weather sealed heat-shrink connectors, using the manufacturer's recommended crimping tools in accordance with their crimping instructions.

WIRE	TRAILER WIRE FUNCTION	MINIMUM WIRE SIZE
PURPLE	Left side electric brake output (all left side brakes)	1.8mm ²
PINK	Right side electric brake output (all right side brakes)	1.8mm ²
WHITE	Trailer battery/frame ground point	1.8mm ²
BLUE	Electric brake controller signal from tow vehicle	1.8mm ²
BLACK	12V DC from tow vehicle trailer harness	1.8mm ²

WARNING

Taking shortcuts when connecting any wires on your caravan/trailer only increases the likelihood that some part of your electrical system will fail.

Make sure connections are durable and sealed against exposure to weather and corrosive elements. One loose connection can disable your entire caravan/trailer brake system.

WARNING

Failure to use the correct wire may result in poor braking performance or brake failure. Incorrect wire size may also result in significant damage to your caravan/trailer or its components.

Undersized wire will prevent electrical circuit protection devices such as fuses or circuit breakers from functioning properly.

WIRING DIAGRAM

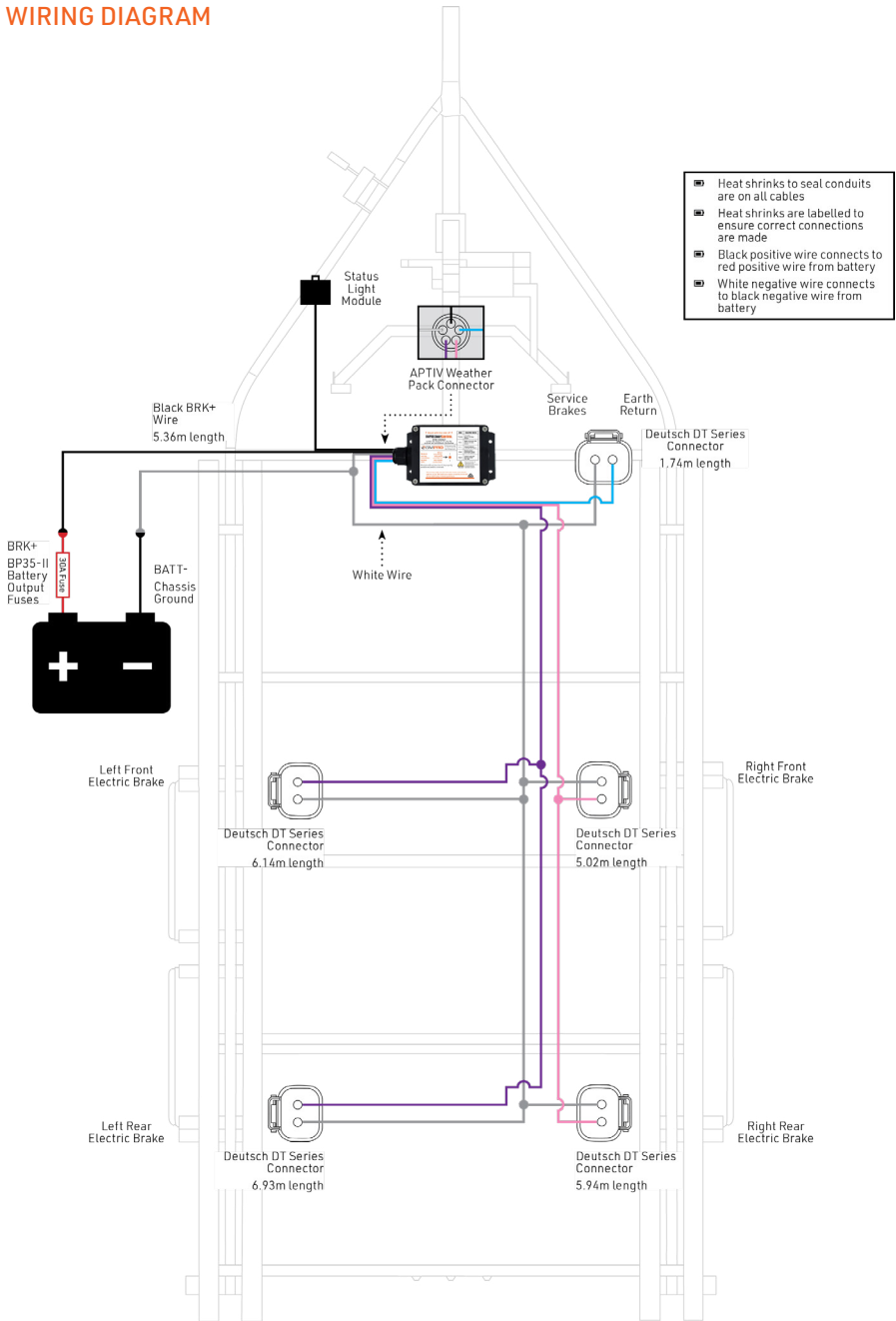

Caravan/Trailer Battery

The caravan/trailer must be equipped with a 12V battery system of greater or equal to 50Ahr.

A full size caravan/trailer battery must be used.

Ground Connections

The caravan/trailer battery ground, the SwayControl ground and the electric brake ground wires must all be securely connected a 1.8 mm² (minimum) wire in order for the SwayControl to function properly.

These must be all fully grounded to a common point on the caravan/trailer.

12V Connections

The tow vehicle 12V charge line, the 12V caravan/trailer battery terminal and the SwayControl 12V (black wire) must be securely connected together with a 1.8 mm² (minimum) wire in order for the SwayControl to function properly. The "hot" wire from the breakaway switch must be connected to the +12V terminal of the caravan/trailer battery.

Electric Brake (Blue Wire) Connections

The tow vehicle brake signal (**BLUE**) wire must be securely connected to the SwayControl brake signal (**BLUE**) wire as well as to the "cold" wire from the breakaway switch.

Left and Right Side Brake Wires

The SwayControl operates the left and right side caravan/trailer brakes independently in order to control caravan/trailer sway. It is very important the correct SwayControl wires are connected to the correct side of the brakes.

The SwayControl **PURPLE** wire must be connected to all left side brakes.

The SwayControl **PINK** wire must be connected to all right side brakes.

Failure to properly connect these wires will prevent the SwayControl from controlling caravan/trailer sway.

STATUS LIGHT MODULE INSTALLATION

Once wiring is completed, route the Status Light cable to the front of the caravan/trailer. Then mount the Status Light module onto a flat surface on the drawbar of the caravan/trailer using self-tapping screws.

Select a location that makes it easy to see the Status Light when looking at the front of the caravan/trailer.

SWAYCONTROL SELF DIAGNOSTICS

The SwayControl performs a self-diagnostic test every time it “wakes-up” upon receiving a signal from the brake controller in the tow vehicle. The Status Light may flash **RED** and **GREEN** approximately six times on start-up then go **GREEN**.

Once in operation, the SwayControl continually monitors the system for faults. If the system is operating properly and no fault is detected, the **GREEN** light will remain on and flicker or pulse.

If the SwayControl detects a fault in the system, the Status Light will turn **RED** and the fault may be diagnosed from the **RED** Status Light flash sequence. The SwayControl continues checking the fault status and the **RED** Status Light will continue to flash until the fault is corrected. Once the fault has been corrected, the **GREEN** light returns.

For more information, refer to **Status Light LED Indicators**.

WARNING

When the caravan/trailer is not moving, every 60 seconds the **GREEN** light will turn off for two seconds, then turn back on. This is normal and indicates normal operation of the SwayControl.

If you notice the **GREEN** light turning off and on every 60 seconds and the caravan/trailer is moving, have your SwayControl checked by your local service centre.

FINAL BRAKE WIRING CHECK AND START UP

To check that the SwayControl is wired correctly:

1. Ensure that ONLY the **PURPLE** and **WHITE** wires from the SwayControl are connected to the left side caravan/trailer brakes and are wired in parallel and not in series.
2. Ensure that ONLY the **PINK** and **WHITE** from the SwayControl wires are connected to the right side caravan/trailer brakes and are wired in parallel and not in series.

After performing the final brake wiring check, the SwayControl is ready for start-up.

The operational status of the SwayControl is indicated by the LED Status Light. The SwayControl is in sleep mode if the LED Status Light is off. The SwayControl will start-up (wake-up) when voltage is applied to the **BLUE** wire.

Once the caravan/trailer is connected to the tow vehicle, apply the manual override on the caravan/trailer brake controller in the tow vehicle. If the SwayControl is installed correctly, the LED Status Light should start flickering **GREEN**.

If the LED Status Light does not come on when applying the manual override on the brake controller, refer to **Status Light LED Indicators** to diagnose potential faults in the installation of the SwayControl.

WARNING

When inspecting caravan/trailer wiring, it is very important that the caravan/trailer brake controller wire from the tow vehicle (blue wire) is ONLY connected to the **BLUE** wire on the SwayControl AND NOT connected directly to the caravan/trailer brakes.

SERVICING

Do not attempt to service the SwayControl yourself, OR dismantle, modify or repair the SwayControl yourself; this will void your warranty. If your SwayControl requires servicing, please consult your BMPRO dealer or visit teambmpro.com for assistance.

STATUS LIGHT LED INDICATORS

SEQUENCE	CONDITION OR FAULT	SOLUTION
Solid GREEN pulsing	Normal operation	
GREEN flash 5 times per second	SwayControl braking is active	
1 GREEN flash every 4 seconds	Module reset to manufacturer default values. Keep trailer still for 60 seconds (minimum) before driving	If module does not return to normal solid GREEN pulsing light after 3 system restarts, have the unit checked at a service centre.
Continuous RED , GREEN flash	Driving on rough terrain and sway control of trailer is disabled	Unit will return to normal operation (GREEN light) when not on rough terrain
No Light	Unit in "sleep" mode	Activate manual override on the brake controller to "wake-up" unit
No Light	No power after "wake-up" from brake controller	Check quality of power, ground and brake controller wire connections Check for any blown fuses on the tow vehicle and trailer
No Light	Over voltage, greater than 20V detected	Check power source voltage, correct voltage is 12-15V
No Light	Low voltage, less than 3V detected	Check power source voltage, correct voltage is 12-15V Check quality of power and ground connections
Solid RED	System malfunction	A service centre repair is required
1 RED flash	System malfunction	A service centre repair is required
2 RED flashes	Sensor malfunction - no sway control of trailer	A service centre repair is required
3 RED flashes	Left side brake short	Correct the short in left side brake wiring
4 RED flashes	Right side brake short	Correct the short in right side brake wiring
Fast RED flashing	Low voltage, between 3 and 6V	Check quality of power and ground connections

If a service centre repair is required, please contact your BMPRO SwayControl Authorised Repair Centre.

SPECIFICATIONS

SWAYCONTROL	
System Voltage	12 - 15V
Power Source	Caravan/trailer house battery
Current Draw (Sleep Mode)	35mA \pm 2%
Sleep Mode	After 30 minutes of inactivity
Current Draw (Sleep Mode)	35mA \pm 2%
Wake-up Mode	Brake controller signal
Preprogramming	No
Auto System Disable (ASD)	Yes
Off-road deactivation	Automatic
Braking Level Adjustment	Automatic
Braking Levels	Independent left/right
Maintenance	None
Status Indicator	LED
Dimensions	146mm x 89mm x 55mm

WARRANTY TERMS AND CONDITIONS

Our goods come with guarantees that cannot be excluded under the Australian Consumer Law. You are entitled to a replacement or refund for a major failure and for compensation for any other reasonably foreseeable loss or damage. You are also entitled to have the goods repaired or replaced if the goods fail to be of acceptable quality and the failure does not amount to a major failure.

This warranty is provided by SETEC BMPRO Pty Ltd (ABN) ("BMPRO") for its products. Warranty benefits are applied along with any rights and remedies required by Australian State and Federal legislation that cannot be excluded. No part of this warranty excludes, restricts or modifies any State or Federal legislation relating to the supply of goods and services which cannot be excluded, restricted or modified.

WARRANTY

BMPRO warrants that the product will be free from any faults in materials and workmanship beginning from the original date of purchase under standard application, installation, use and service conditions, subject to the exclusions and limitations detailed below. The warranty period of the product is two years.

If, before the warranty period has ended, a fault occurs with the product and BMPRO finds the product is defective in materials or workmanship, BMPRO at its discretion will subject to further rights accorded by the Australian Consumer Law to either:

- Repair the defective product
- Replace the defective product
- Provide a refund to the purchaser for the price paid at purchase for the defective product.

WARRANTY CLAIMS

Refer to your manual before using the product. Most BMPRO products are designed to be installed by a suitably qualified installer. The products should be carefully inspected by you or your installer before installation for any visible manufacturing faults. If a product has been installed incorrectly, BMPRO accepts no responsibility on top of our consumer guarantee obligations.

1. If a fault covered by warranty occurs, the purchaser must either contact the dealer where the product was purchased within 7 days, or BMPRO at the contact details listed.
2. All warranty claims must include: (a) proof of purchase of the product; (b) complete details of the alleged fault; (c) any relevant documentation related to the fault (such as photographs or maintenance records); (d) return material authorisation (RMA) number.
3. The product must be made available to BMPRO or its authorised installer for inspection and testing within 14 days of contacting BMPRO or the dealer.
4. The reasonable cost of delivery and installation of any products or components of products that have been repaired or replaced to the place of purchase notified to BMPRO is covered by the warranty provided by BMPRO, along with the reasonable costs of removal and return of any products determined by BMPRO to be defective.
5. If, on return to BMPRO or on investigation by BMPRO, inspection and testing determines there is no fault in the product, the purchaser must pay BMPRO's reasonable costs of testing and investigating the product, as well as transportation and shipping costs.

REGISTER A WARRANTY OR REPAIR WITH BMPRO

To register a warranty or repair with BMPRO:

1. Lodge a support request via teambmp.com/technical-support or email customerservice@teambmp.com
2. If agreed with the BMPRO Product Specialist team, register a warranty claim or repair via teambmp.com/warranty-claim or email customerservice@teambmp.com to obtain a Return Material Authorisation (RMA) number.
3. Package and send the product to:

BMPRO Warranty Department
19 Henderson Road
Knoxfield, VIC 3180

Please mark RMA details on the outside of the packaging.

4. Ensure your package also includes a copy of the proof of purchase, a complete description of the fault and your contact details including phone number and return address.

EXCLUSIONS

This warranty will not be applicable where: (a) the product has been altered, modified or repaired by someone other than BMPRO, an authorised installer or a qualified auto electrician; (b) the product has not been installed properly by either the user or manufacturer; (c) BMPRO cannot establish a fault in the product after inspection and testing; (d) the product has been used for purposes other than that for which it was designed; (e) the fault in the product has occurred due to a failure by the purchaser to ensure proper use and maintenance of the product according to BMPRO's instructions, recommendations and specifications (including maintenance); (f) the product has been subjected to abnormal conditions, such as environmental, temperature, water, fire, humidity, pressure, stress or similar; (g) the fault has been caused by abuse, misuse, neglect or accident; (h) the fault has been caused by a power surge or other kind of fault in the supply of electricity; (i) unauthorised parts or accessories have been used on or in relation to the product; (j) the appearance of the Product has deteriorated; or (k) the fault is a result of common wear & tear.

LIMITATIONS

No express warranties or representations are made by BMPRO other than what is set out in this warranty. The absolute limit of BMPRO's liability under this express warranty is the repair or replacement of the product or part of the product.

CONTACT

BMPRO's contact details for warranty claims are:

SETEC BMPRO Pty Ltd
19 Henderson Road,
Knoxfield, VIC 3180
Phone: (03) 9763 0962
Email: customerservice@teambmp.com

Warranty Claim and Product Repair Form:
<https://teambmp.com/warranty-claim/>

Registering your BMPRO product is an important step to ensure that you receive all the benefits you are entitled to.

Please complete the online registration form at <https://teambmp.com/product-registration/> for your new product today.

POWERING YOUR ADVENTURES.



**TEAM
BMPRO
.COM**

BMPRO
customerservice@teambmpro.com
19 Henderson Rd, Knoxfield VIC 3180 Australia
teambmpro.com