

HYUNDAI
POWER PRODUCTS



CHAIN SAW

HY3810 HY4110

Instruction Manual

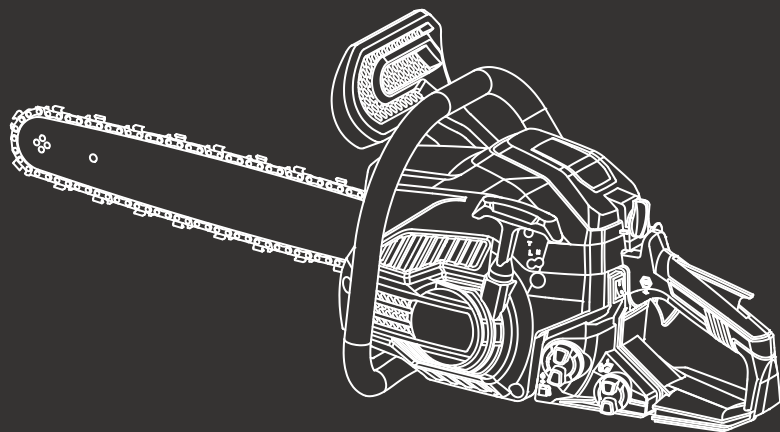

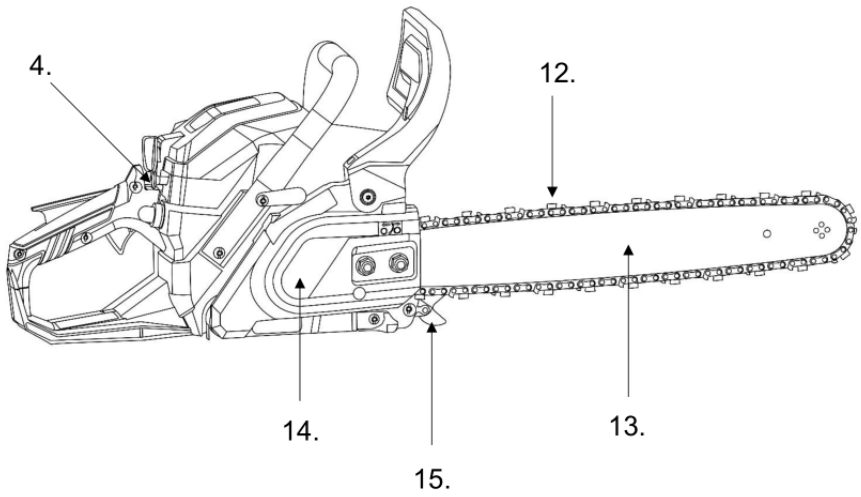
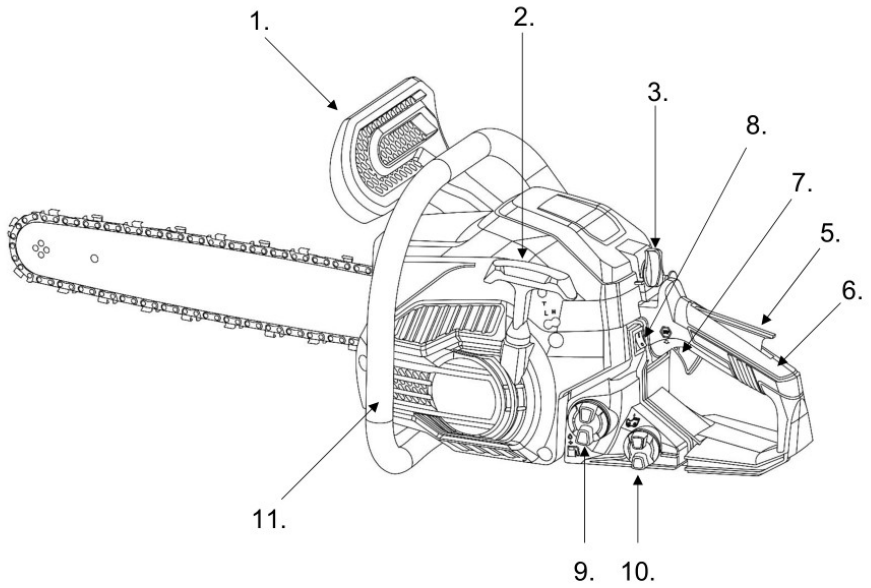

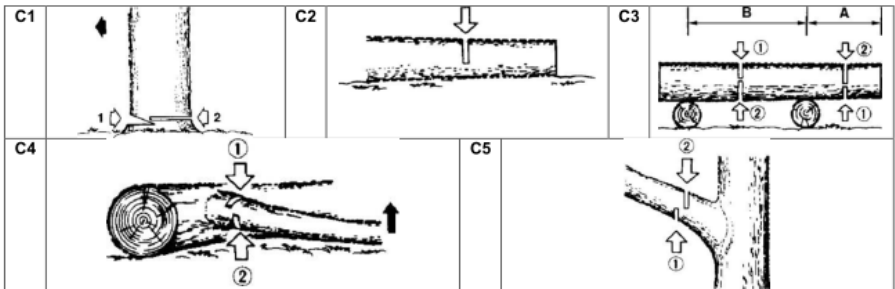
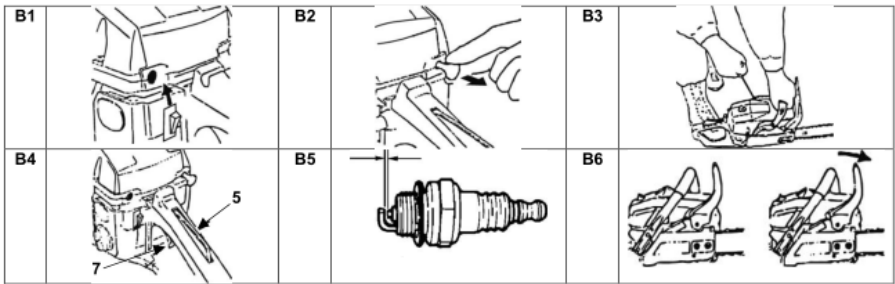
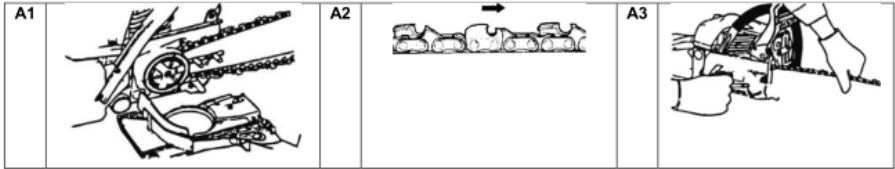
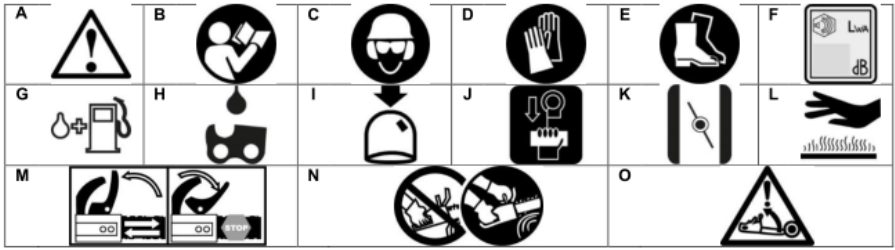



BEFORE THE FIRST USE



Be sure to read the full instructions!

Read the user manual before use before first use. Instructions contain important information for the safe use of this product.



Add fuel

There is no fuel in the engine!

Fuel must be added to the tank before use. The chainsaw operates with a mixture of 1 part of oil for two-stroke engines and 40 parts of unleaded 95 octane gasoline.

For a detailed description of fuelling, see **Fuel**.



Add chain oil

Special chain oil must be added in the oil tank before use. For a detailed description of adding chain oil, see the chapter **Oil for the chain**.



Checking chain tension

Check the tension of the chain and set it as described in the chapter **Installing the guide bar and chain if needed**.



Wear protective clothing

Always use appropriate personal protective equipment when using the product to protect the head, hearing and eyes. Also wear protective clothing resistant to cuts, gloves and non-slip protective footwear.



Get acquainted with the operation of the device

In order to use the product safely, it is important to fully familiarize yourself with the operation of the device, maintenance and safety requirements.

Instruction manual

- This instruction manual applies for this device. It contains important information for starting the use and handling with the product.
- Before you start using the device, read the instruction manual carefully and in its entirety, specially the safety instructions. Failure to follow this instruction manual can result in serious bodily injuries or damage to the device.
- The instruction manual is based on the standards and regulations valid in the European Union.
- When abroad, you should also comply with the regulations and laws of the individual country.
- Save the instruction manual for later use. If you give the device to a third person, also hand him or her the instruction manual.

Explanation of symbols

The following symbols and warning words are used in the instruction manual:



WARNING!

This warning symbol/word marks danger, which can, if not avoided, can result in material damage, death or serious injuries.



NOTE!

The symbol gives additional useful information about the use of the device.



WARNING!

- **The manufacturer shall not be held liable for any damage arising from incorrect use of the device, incorrect maintenance and interventions regarding the device with the purpose to replace or modify its parts. Only service authorised by the manufacturer is allowed to perform works on the device.**
- **Do not overload the tool. Overloading and repeated engine blocking can damage the tool, and consequently reduce the lifetime of the product.**
- **The tool is not intended to work in a potentially explosive atmosphere!**



GENERAL SAFETY MEASURES

Read all the safety warnings and instructions that are included in the manual.

Failure to observe the safety warnings and instructions may result in the risk of exposure of people and domestic pets to electric shock, fire and / or serious injuries.

Save all safety warnings and instructions (including those that are on the tool) for the future.

In the safety instructions, the terms "tool, product and chain saw" are used to refer to chain saws operating with a petrol engine.

General safety instructions

User requirements

Insufficiently informed users may endanger themselves, others, and property due to improper use.

- The user must read and understand the operating instructions and safety warnings.
- Some tasks require special training and special skills. If you are in doubt, contact an expert.
- Beginner users need training with an expert to work with the tool or they must attend a course in an educational institution to use the tool.
- Only deliver the product to users who have experience in working with the tool. Always hand over the instructions for use.
- Whenever you do not use the tools, always store them without compromising your safety and protect them against unauthorized use.
- The user is responsible for all accidents and hazards that may harm other persons or their property.
- Children, adolescents and people with reduced physical, perceptual or mental abilities should not use the tool. The only exception are adolescents over 16 years of age under the supervision of an expert.
- Handling the tool requires great attention. Keep an eye on what you are doing and use logic when working with the tool.
- Do not use the tools for more than 10 minutes at a time and take 10 to 20 minute breaks during the working steps.
- Do not use tools if you are tired or under the influence of drugs,

alcohol or medicines. A moment of carelessness when using the tool can cause serious personal injury.

Environmental requirements

Do not expose the tools to rain or moisture.

Safety of persons

- Wear head, eye, hands and hearing protection when using the tool.
- Wear personal protective equipment, e.g. non-slip protective shoes, protective helmet, face protection, hearing protection, protective clothing, resistant to cuts, and protective gloves. This reduces the risk of injury.
- Wear suitable clothing Do not wear wide clothes, jokes, ties or jewellery. Do not bring hair, clothes and gloves close to movable parts.
Loose clothing, jewellery or long hair can get stuck in moving parts.
- Always use hearing protection. The noise generated by the tool can cause hearing damage.
- If you often work with the tool, your doctor will often need to check your hearing.
- If you wear hearing protection, you will no longer be aware of the noise so clearly. Therefore, pay more attention to visual stimuli.
- Always wear safety glasses or safety helmet with a visor to protect yourself from flying cut material.
- An electrical ignition device on the tool creates a small electromagnetic field. If you have a pacemaker or similar implant, consult your doctor before using the tool to reduce the risk to health.
- The exhaust sound attenuator on the front of the tool becomes very hot during operation and remains hot even after switching off the engine. Do not touch this area as there is a risk of burns!
- Make sure that children do not play with the packaging foil. They can become entangled and suffocate when playing.

Requirements for the work area

- Do not use chain saws in indoors or in poorly illuminated areas. The exhaust gases of the engine are toxic and can cause suffocation.
- The workplace must always be clean and well lit. Disorder or poor light and visibility can cause accidents.
- Do not work at night or in adverse weather conditions, e.g. in fog, rain, snow, ice or wind. There is an increased risk of an accident!

- If you use a chainsaw in or after rain, particular consideration should be given to the precautionary measures, as the soil can be very slippery.
- Children, other persons and animals must not be in the vicinity when using a chainsaw. In the event of a distraction, you can lose control of the chainsaw.
- Before sawing, make sure that there are no persons, animals or objects in the danger zone.
- National and / or municipal regulations may limit the time of the use of noise-producing motor devices. Find out about this in your municipal administration.
- When working in a highly flammable environment (dry grass, bushes, etc.) and during draught, have prepared fire extinguishers due to the danger of forest fire.

Adding fuel

- Before adding fuel mixture, you must always turn off the engine and carefully inspect the environment so that no sparks or open flames are in the vicinity.
- Gasoline is very flammable. When refuelling, keep a sufficient distance to open flames and do not smoke.
- Before refuelling or adding oil into an appropriate tank, turn off the engine and wait until the tool cools down. Otherwise, the spilled fuel can ignite.
- Only add fuel in a well-ventilated area. Collected gasoline vapours can ignite or explode.
- Avoid contact with skin and eyes with fuel or oil. Do not inhale gasoline vapour.
- Make sure that gasoline or chain oil does not get into the ground. Use a suitable base.
- After filling, close the covers of the tanks to prevent leakage of fuel.

Wipe up the spilled fuel and run the tool at least 3 m from the filling site. This will prevent the exhaust fumes of the engine to ignite the spilled gasoline.

Use

- Never work alone! In an emergency, someone must be near.
- Check the correct operation of the safety devices before starting work.

Do not use a chainsaw if it is damaged or does not work reliably.

- Always hold the chain saw with the right hand for the rear handle and with the left hand for the front handle. Holding a chainsaw the other way increases the risk of injury and must not be done.
- While the chainsaw is working, do not approach body parts to the chain.

Before starting the chainsaw, make sure that the saw chain does not touch anything. When working with a chainsaw, a moment of carelessness can lead to the chain catching clothing or parts of the body.

- Avoid any unusual body stance. Keep a safe stand and always maintain balance. This way, you can control the chainsaw in unexpected situations.
- Do not use the chainsaw above the shoulder height.
- Do not work on a tree with a chainsaw. There is a risk of injuries when working on trees.
- Use a chainsaw only when standing on solid, secure and level ground. Slippery or unstable surfaces (e.g. on the ladder) can lead to loss of balance or control over the chainsaw.
- When a chain saw comes in contact with stones, nails, or other hard objects, immediately stop the engine and check the chain and guide bar for damage.
- The chainsaw must not fall to the ground, and you should not use it to hit obstacles, and never use the guide bar as a lever.
- In case of significant changes in behaviour, immediately turn off the chainsaw and find the cause.
- Only saw wood. Do not use chainsaws for work for which it is not intended. Do not use chainsaws for sawing plastic, masonry or non-wood construction materials. The use of a chain saw for work for which it is not designed can lead to dangerous situations.
- When sawing a tensioned branch, consider that the branch will bounce back. When the tension in the wood fibres decreases, the tensioned branch can hit the operator and / or the operator may lose control of the chainsaw.
- Take special care when sawing bushes and young trees. Thin material can be caught in the chain and hit you or you may lose balance because of it.
- Carry the chainsaw when turned off and hold it on the front handle and the chain must be facing away from the body. Always install the protective cover when transporting or storing the chainsaw.

- Turn the engine off before checking the tension of the chain, before replacing the chain, before removing the chain and before removing the faults! For maintenance work, extract the plug from the spark plug to prevent accidental starting of the engine.
- Follow the instructions for lubrication, chain tensioning and replacement of accessories. Poorly tensioned or lubricated chain can tear or increase the risk of kickback.
- The cutting tool must be sharp and clean. You must regularly sharpen the chain and replace worn parts in due time. A well-groomed cutting tool with sharp cutting edges does not get stuck as frequently and is easier to guide.
- Handles must be dry, clean and free of oil and grease. Slippery, oiled hands are slippery and lead to loss of control.
- Make sure that all movable parts are operating faultlessly and do not jam, whether parts are broken or damaged so as to negatively affect the operation of the chainsaw. The damaged parts must be repaired before using the chainsaw. Many accidents occur due to poorly maintained tools.

KICKBACK

Kickback may occur when the tip of the bar touches the object or when it bends and the chainsaw gets stuck in the cut. A touch with a tip of the bar may in some cases lead to an unexpected, rearward reaction, in which the bar is thrown up in the direction of the operator. If the chain gets stuck at the upper edge of the bar, it can quickly push the chainsaw towards the operator. If the chain gets stuck at the lower edge of the bar, it can quickly kickback the chainsaw from the operator. Each of these reactions can result in loss of control of the saw and serious bodily injuries. Do not rely solely on safety devices installed on the chainsaw. As a user of a chainsaw, you must take various measures to ensure that you can work without accidents and personal injuries:

- Hold the saw firmly with both hands, with the thumb and fingers locking the handle of the chainsaw.
- Always hold the chainsaw with both hands when sawing. Never work with just one hand!
- Place your body and hands in a position where you can stop the kickback. If the operator has taken the appropriate measures, he can control the kickback forces. Never let go of the chainsaw.
- Avoid the unusual position of the body and do not use the saw above the shoulder height. This prevents unintentional contact with

the tip of the sword and allows better control of the chainsaw in unexpected situations.

- Always use replacement bars and chains recommended by the manufacturer. The wrong replacement bar and the chain can lead to a chain breakage and / or kickback.
- Follow the manufacturer's instructions for sharpening and maintaining the chain. If the depth limiter is set too low, this will increase the possibility of kickback.
- Never cut it with the tip of the bar.
- Make sure that there are no nails or metal parts in the sawing area, and in particular watch the nails or the iron pieces around the sawing area. Also be careful when cutting hardwood in which the chain can get stuck. This can result in kickback.
- Start the cut at full power and keep the chainsaw at the highest speed during sawing.
- Be extremely careful when inserting a chainsaw chain into a previously created cut.
- Do not saw branches or parts of wood where change of position may occur during sawing or where the cut may close during sawing.
-

Designated use

The gasoline chainsaw is intended for sawing thin wood outdoors and is not suitable for professional use.

Use the product only with original accessories and only as described in these operating instructions. Any other use is considered inappropriate and can result in material damage or even physical injury.

Device parts

- | | |
|-----------------------------|--|
| 1. Front arm guard | 8. On/Off switch |
| 2. Ignition handle | 9. Fuel tank cap |
| 3. Air filter cover | 10. Chain oil tank cap |
| 4. Choke | 11. Front handle |
| 5. Lock for throttle button | 12. Chain |
| 6. Rear handle | 13. Guide bar of the chain |
| 7. Throttle button | 14. Cover of the noise / clutch silencer |
| | 15. Toothed support |

Explanation of symbols

- A. Warning
- B. Read the instructions for use

- C. Mandatory use of protective equipment for protection of the head, hearing and eyes.
- D. Mandatory use of protective gloves.
- E. Mandatory use of protective safety shoes.
- F. Noise level
- G. Refuelling cap
- H. Chain oil cap
- I. Fuel pump membrane
- J. Ignition handle
- K. Choke handle
- L. Hot surface
- M. Chain brake
- N. Do not use the product with just one hand. Hold the product firmly with both hands.
- O. Beware of the possibility of kickback.

Data on the nameplate

You will find a nameplate on the product that contains basic information about the chainsaw. This label is usually located at the top or on the product page. Data stated on the nameplate:

- Chainsaw model
- Power in kilowatts (kW)
- Engine volume
- Engine type
- Engine speed when loaded
- Oil and fuel mixture
- Weight
- Year of manufacture
- Batch number

Installing the guide bar and chain



WARNING! Wear protective gloves when installing.

1. Push the guard towards the chain to release the chain brake. (1)
2. Unscrew the screws and remove the unit cover. (14)
3. Install the toothed support on the motor unit. (15)
4. Insert the bar with the guide on the motor pin. (A1)
5. Place the chain first around the drive unit and then around the bar to fit properly to the toothed wheels.

NOTE: Pay attention to the direction of the chain. (A2)

6. Install the tensioner nut on the unit cover, then install the cover on the device. Tighten the screw with your hand.

NOTE: When installing the unit cover, the lid must first be installed on

the hook on the motor unit.

7. Pull up the chain and tighten the tensioning screw with a screwdriver to tighten the chain. (A3)
8. Now you can screw the tensioner nut with the supplied key.
9. Check the chain before working. The chain must move if you drag it by hand. If necessary, tighten or release the chain by tightening or unscrewing the tensioning screw.

Fuel and chain oil



Mixture of fuel and oil

The recommended blend of fuel and oil is 1:40 or 2.5% of the mixture. Example: Add 0.25 dl of oil to 1 litre of fuel

1. Place the chainsaw with the right side on the appropriate base.
2. Unscrew the fuel tank cap (9) and remove it.
3. Add mixture for two-stroke engines in the fuel tank. Be careful not to overfill the tank.

NOTE: If you overfill the tank, immediately wipe up the spilled fuel. Wait for any residual fuel to evaporate before restarting the engine.

4. Attach the fuel tank cap

Chain oil



WARNING!

Only use special chain oil for chainsaws.
Do not use old spent oil.

1. Place the chainsaw with the right side on the appropriate base.
2. Unscrew the chain oil tank cap (10) and remove it.
3. Fill the chain oil in the tank. Be careful not to overfill the tank.
4. Attach the fuel tank cap
5. Wipe off spilled oil if necessary.

Engine ignition



WARNING!

The chainsaw must be fully assembled before starting the device. Check fuel and chain oil level.

1. For a cold start, press the fuel pump approximately 3x, or until the

fuel flows into the pump.

2. Move the On / Off button to the "I" position. (B1)
3. Push the choke out to position 1. (B2)
4. Firmly grasp the front handgrip with your left hand, and the ignition handgrip with your right hand. (B3)
5. Pull the ignition lever towards you until you feel resistance.
6. Pull the lever firmly against you.

NOTE: Do not pull the handle fully, as it may damage the starter.

7. Do not release the lever, but put it into the starting position.
8. Repeat steps 5 and 6 until the engine starts. When the engine starts, push the choke to the working position (inside).
9. Lightly add the throttle and allow the engine to run for approximately one minute to warm up to working temperature.

Choke (B2)

1. Position - cold ignition
2. Working position

Throttle button (B4)

The throttle button controls the speed of the chain rotation.

1. Use the right hand palm to press the button to lock the throttle button (5) to release the gas feed button.
2. Press the throttle button (7) and the chain will start to rotate.

Stopping the engine

Move the On / Off button (8) to the "O" position to turn off the engine.

Chain brake (B6)

The chainsaw is equipped with a chain brake. In the event of a kickback, this brake will stop the chain.

If kickback occurs during work, the hand guard hits your wrist. The hand guard jumps forward and the brake stops the chain.

1. Push the hand guard forward to activate the chain brake.
2. Pull the hand guard back to release the chain brake.

Checking the brake

Regularly check if the chain brake is working properly.

1. The chainsaw should be turned on.
2. Push the hand guard forward to activate the chain brake.
3. Press full throttle for a short time (max. 2-3 seconds).
4. If the chain does not move, the brake is working properly.

**WARNING!**

If the brake does not work properly, take the chainsaw to an authorized service.

Cutting down trees**WARNING!**

Carefully read and follow all instructions before starting work!

Logging

1. Determine the direction of the fall according to the wind, the angle of the tree, the direction of growth of heavy branches and similar factors.

2. The surrounding area of the tree should be cleared to provide solid standing point the easiest escape route.

3. Cut a triangle shape in the size of one-third, on the side where the tree will fall. (C1)

4. Make a horizontal cut on the opposite side and slightly higher than the lower side of the triangular shape. (C1)

NOTE: The horizontal cut should be precise and levelled. When felling, about 1/10 of the diameter of the trunk must remain as a break-off edge. Do not cut away the break-off edge as it serves as a hinge so that the tree does not fall uncontrollably.

5. When the tree begins to fall, turn off the chain saw and start to pull move away from the tree.

WARNING! Alert others about the danger when the tree is falling.

Sawing the fallen trunk**WARNING!**

- Fix the trunk to prevent it from moving.
- Prepare good support.
- Do not stand on the trunk.
- Pay attention to rolling over, especially when working on the slope you need to stand on the upper side of the trunk.
- Check the direction of the bending force of the trunk before work.

Always finish cutting on the opposite side of the trunk direction.

Lying trunk (C2)

Cut up to half the trunk, then turn the trunk and cut the opposite side.

Supported trunk (C3)

- In zone A, cut from the bottom first and finish cutting down from the top.

- In zone B, cut from the top first and finish cutting up from the bottom.

Cutting the branches of a fallen tree (C4)

First, check which side of the branch is curved. Make the initial cut on the bent side and end by sawing on the opposite side.

Cutting an upright branch (C5)

First make a cut from the bottom up, then finish with a cut from the top down.

Maintenance

Regular maintenance is important for proper functioning of the chainsaw. Thoroughly clean the chainsaw after each use.

Regular maintenance can significantly extend the lifespan of this tool.



NOTE! In case of malfunction, take the chainsaw to an authorized service.

Air filter

1. Remove the air filter cover (3) and the air filter.
2. Clean the air filter with warm soapy water. Wait for the air filter to dry before reinstalling it.
3. If the filter is too dirty or damaged, replace it with a new one.

Spark plug (B5)

1. Clean the dirty spark plug and set the spacing at the electrode to 0.65 mm.
2. Replace the spark plug if necessary.



WARNING!

Use a recommended spark plug. The replacement spark plug should be of the same type as the included spark plug of the manufacturer.

Guide bar of the chain

When removing the chain bar (13), remove the sawdust on the bar and the lubrication opening.

Turn the bar regularly. This ensures that it is evenly used.

Tensioning the chain

The chain tensioning screw is located on the right side of the device under the tensioner nut.

- Tighten the chain tensioning screw with a screwdriver to tension the chain.
- Unscrew the screw to release the chain.

Sharpening the chain

A round file and a template is used for grinding the cutter teeth. For information on the recommended dimensions of the file, see the Specifications section.

Grinding procedure:

1. The chain must be properly tensioned.
2. Put the file on the cutter tooth at an angle of the tooth blade travel.
3. The file can only move forward. When returning, lift the file from the tooth.
4. First, grind all the teeth on one side, then on the other side of the chain.

Other

Check for fuel leaks, untightened screws, damage of main parts, especially on the coupling handle and chain bar. If you find any errors, you must correct them before using the device again.

Storage and transport

Keep the device in a dry place out of the reach of children. Before storing for a longer period of time, it is advisable to empty the fuel tank and chain oil. Guide bar of the chainsaw should be covered with a shield when not in use.

When transporting the device, use appropriate protection for the guide bar of the chain. Carry the device with the engine off and with the guide bar facing backwards, turn the silencer away from your body. Improper maintenance and removal or changes in safety components can lead to injuries.

SERVICING

For any repairs during the warranty period or after it, please contact an authorised repair service, which will gladly help you. If the power cord is damaged, we recommend that, for safety reasons, you contact an authorised repair service, which will replace the cord.

Before you hand over the device to a repair service, clean it and put it the original packaging.

Specifications

Model:	HY3810
Engine type:	2-stroke
Engine volume:	37 cm ³
Engine cooling:	Air-cooled
Engine power	1,2 kW
Rotation speed:	2.700 - 12.000 min ⁻¹
Oil and fuel mixture:	40:1 (2.5%) - oil for two-stroke engine
Fuel tank capacity:	310 ml
Oil tank capacity:	200 ml
Starting system:	Manual startup
Plug type:	L7T
Chain oil:	Chain lubrication oil for chainsaws
Oil supply system:	Automatic pump with regulator
Weight (without bar and chain):	4.5 kg
Guide bar of the chain:	Toothed / 355 mm
Diameter of the circular grinding tool:	Ø 4 mm
Sound pressure level $L_{p(A)}$:	97 dB(A)
Sound power level $L_{W(A)}$:	111 dB(A)
Vibration level (front handle):	4,790 m/s ² , K=1,5

Model:	HY4110
Engine type:	2-stroke
Engine volume:	40.1 cm ³
Engine cooling:	Air-cooled
Engine power	1,2 kW
Rotation speed:	2.700 - 12.000 min ⁻¹
Oil and fuel mixture:	40:1 (2.5%) - oil for two-stroke engine
Fuel tank capacity:	310 ml
Oil tank capacity:	200 ml
Starting system:	Manual startup
Plug type:	L7T
Chain oil:	Chain lubrication oil for chainsaws
Oil supply system:	Automatic pump with regulator
Weight (without bar and chain):	6 kg
Guide bar of the chain:	Toothed / 355 mm
Diameter of the circular grinding tool:	Ø 4 mm
Sound pressure level Lp _(A) :	97 dB(A)
Sound power level Lw _(A) :	111 dB(A)
Vibration level (front handle):	4,790 m/s ² , K=1,5

HYUNDAI

POWER PRODUCTS

IMPORTER:

**HP EQUIPMENT PTY LTD
547 TARRAGINDI ROAD
SALISBURY QUEENSLAND
AUSTRALIA 4107
PH: 1300 863 503**

LICENSED BY HYUNDAI CORPORATION, KOREA