



User Guide & Warranty



ELBC 2000 Electric Brake Controller

Elecbrakes is a proportional electric brake controller. Mounting to the trailer the ELBC 2000 provides the latest in electric brake controller technology. Connecting to the in-vehicle controller via Bluetooth, Elecbrakes removes the need to hard wire the tow vehicle with a brake controller. Multiple braking programs allows the driver to set up brake responses according to change in load or driving conditions. Fully encased in resin, the ELBC 2000 electronics are water, dust and shock proof.

7/22 Reliance Drive,
Tuggerah NSW 2259

1300 516 248

info@elecbrakes.com

The Elecbrakes logo is a registered
trade mark of Elecbrakes Pty Ltd.



Contents

Parts	Pg. 5
01. Mounting Orientation	6
02. Attaching the Unit to the Trailer	8
03. Trailer Plug Wiring Guides	10
04. Electrical Connection	16
05. First Time Setup - Smartphone	19
06. Getting Started	24
07. Remote Guide	37
08. Troubleshooting Guide	48
09. Warranty	53



Parts

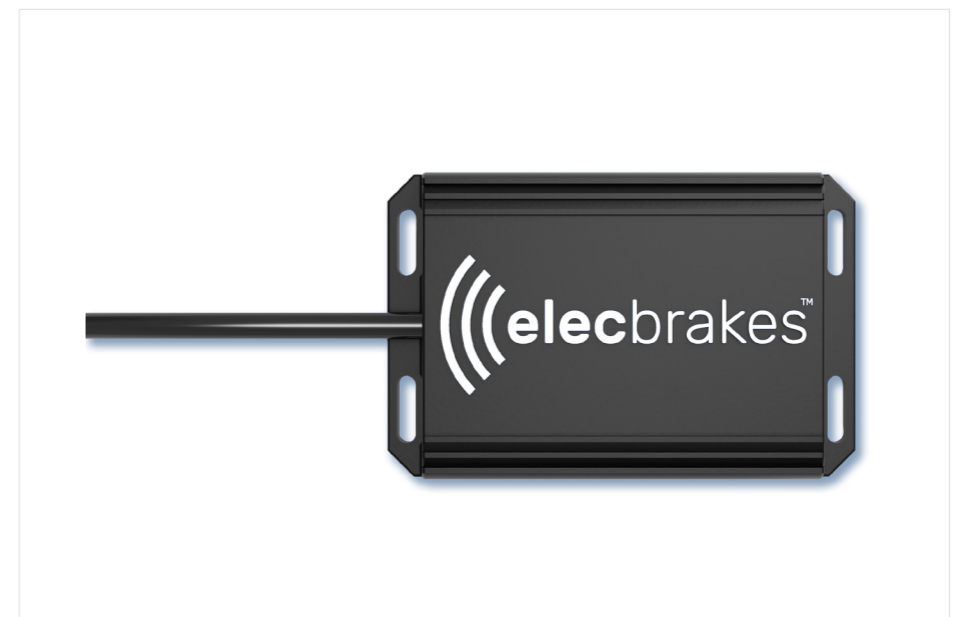

ELBC 2000 Electric Brake Controller.

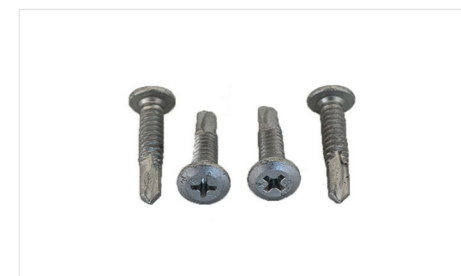

4 x Mounting Screws.

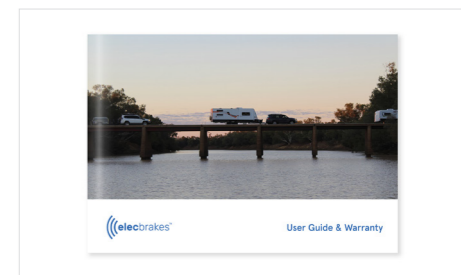

User guide link card.

01.

Mounting Orientation

Elecbrakes can be mounted in various locations on the trailer.

When mounting, allow access to the trailer wiring loom or plug to connect to the electrical circuits. Ensure that the unit is mounted on a flat surface avoiding inclines.

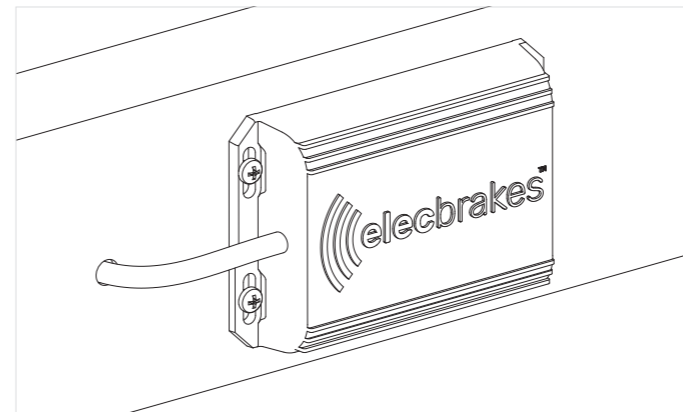

Side face of chassis rail or draw bar.

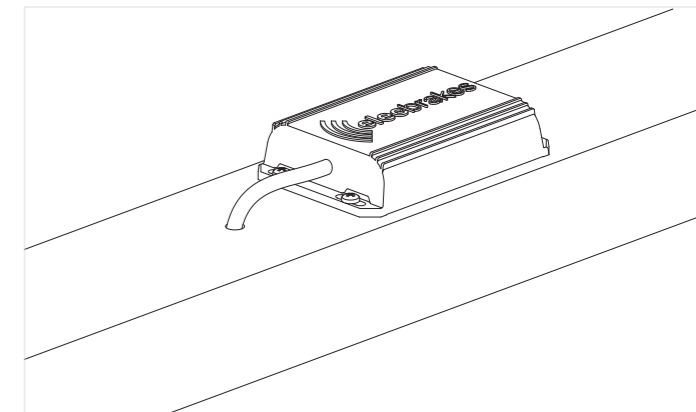

Top face of chassis rail or draw bar.

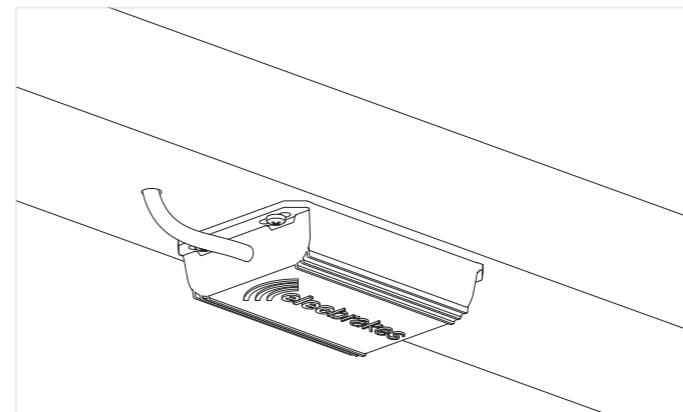

Bottom face of chassis rail or draw bar.

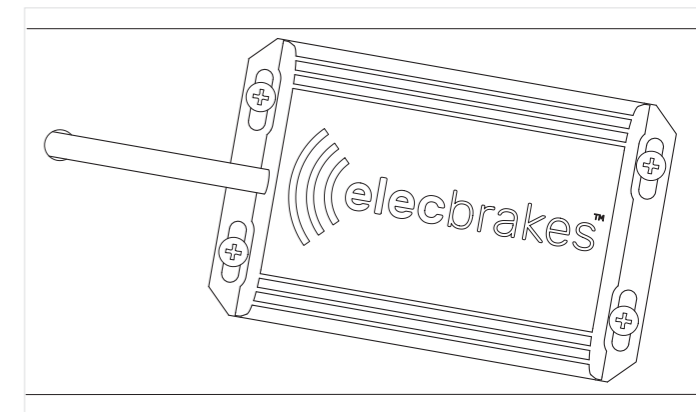

❌ Avoid mounting on inclines.

02.

Attaching the Unit to the Trailer

What you'll need:

- Drill
- 2-3mm drill bit
- No. 2 Phillips driver
- Tape measure
- Marker
- Lubricant

The trailer wired leader (TWL) can be spliced into the loom or joining the to the wires in the trailers plug. It's recommended that any spliced joints are sealed with a shrink tube and soldered to provide the best possible connection.

Measure the length of the leader to gauge where to mount the unit.

When mounting the device avoid placing it in metal tool boxes or surrounding the device by metal. Mounting contrary to this advice may result in poor signal connectivity.

The device has a fibre reinforced case and a urethane resin fill to protect the electronics.

Mounting to the inside or outside of the draw bar is recommended.

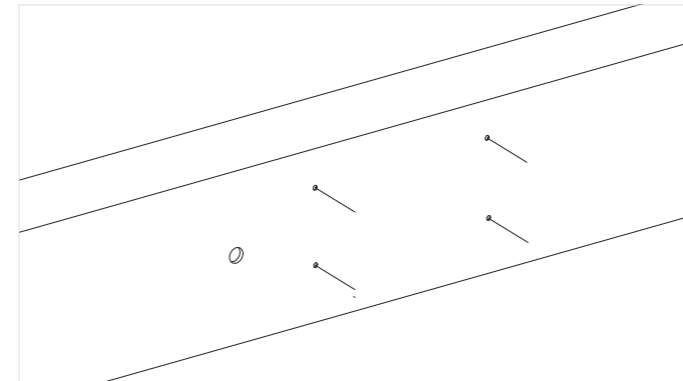

1. Pre-drill holes using 2-3 mm drill.

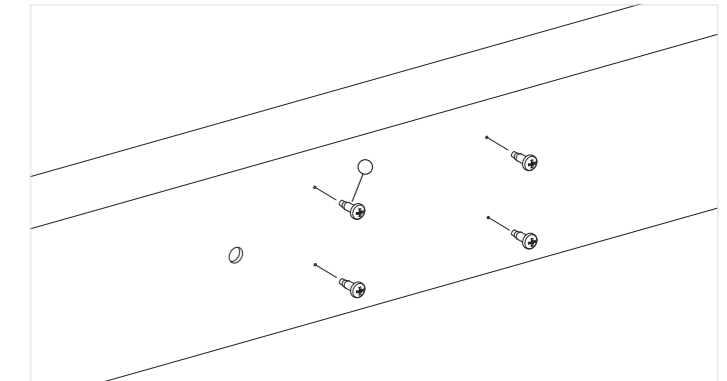

2. Lubricate screws before tightening.

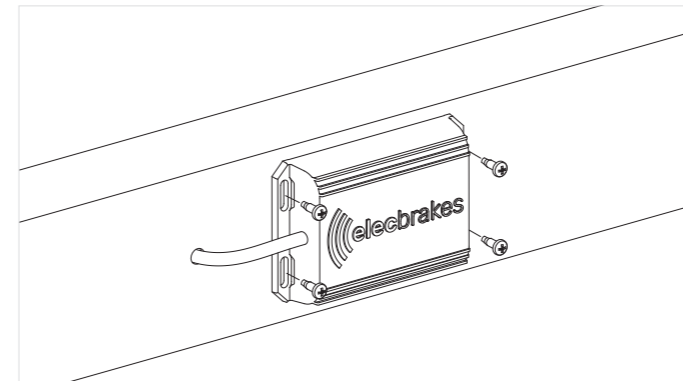

3. Place unit in correct location and attach with self-taping screws, No.2 Phillips driver bit and a cordless drill.

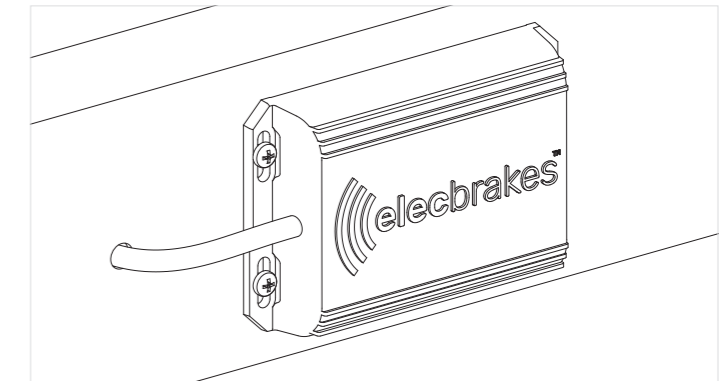

03.

Trailer Plug Wiring Guides

7 Pin Flat Plug and Socket

Pin No.	Circuit	Colour
1	Left-hand turn	Yellow
2	Reversing signal	Black
3	Earth return	White
4	Right-hand turn	Green
5	Service brakes	Blue
6	Stop lamps	Red
7	Rear lamps, clearance & side marker lamps	Brown

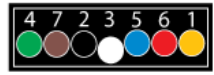

7 Pin Plug



7 Pin Socket

Cable entry view

12 Pin Flat Plug and Socket

Pin No.	Circuit	Colour
1	Left-hand turn	Yellow
2	Reversing signal	Black
3	Earth return	White
4	Right-hand turn	Green
5	Service brakes	Blue
6	Stop lamps	Red
7	Rear lamps, clearance & side marker lamps	Brown
8	Battery charger/winch	Orange
9	Auxiliaries/battery lead	Pink
10	Earth return	White
11	Rear fog lamp	Grey
12	Auxiliaries	Violet



12 Pin Plug



12 Pin Socket

Cable entry view

Wiring guides
courtesy of
narva.com.au

7 Pin Large Round Plug and Socket

Pin No.	Circuit	Colour
1	Left-hand turn	Yellow
2	Reversing signal	Black
3	Earth return	White
4	Right-hand turn	Green
5	Service brakes	Blue
6	Stop lamps	Red
7	Rear lamps, clearance & side marker lamps	Brown



7 Pin Plug



7 Pin Socket
Cable entry view

7 Pin Small Round Plug and Socket

Pin No.	Circuit	Colour
1	Left-hand turn	Yellow
2	Reversing signal	Black
3	Earth return	White
4	Right-hand turn	Green
5	Service brakes	Blue
6	Stop lamps	Red
7	Rear lamps, clearance & side marker lamps	Brown



7 Pin Plug



7 Pin Socket
Cable entry view

Wiring guides courtesy of narva.com.au

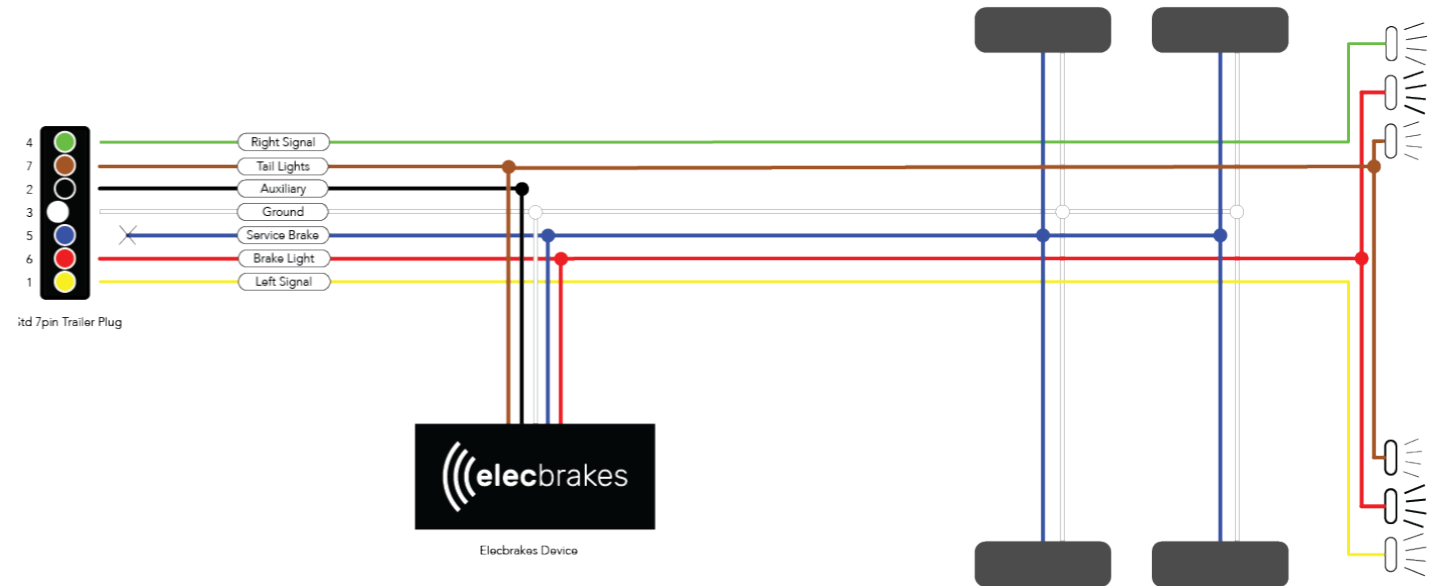

Single or Dual Axle Trailers to 4.5 Tonne ATM

Elecbreaks can be wired into the trailers electrical circuit by splicing into the loom or joining the wires in the trailer plug.

Elecbreaks when connected to the trailers electrical circuit, draws power from multiple circuits.

Pin 7 - Tail Light

Pin 6 - Brake Light

Pin 2 - Auxiliary (optional)

Wiring Notes

Auxiliary power is optional. All Elecbreaks Plug and Play adapters are wired to support an auxiliary power source from the vehicle. That can be supplied on any of the following circuits. Pin 2, Pin 9 or an Andersen plug.

When wiring into the trailer circuits using the trailer wired leader(TWL) the black wire is an auxiliary input for Elecbreaks and can be connected to Pin 2, Pin 9 or an Andersen plug.

Tri Axle Trailers to 4.5 Tonne

Elecbreaks will operate on tri axle trailers all wheels braked when the following wiring option is provided.

The device must be connected to a constant 12-24v circuit of a minimum of 30 amps.

The tail light circuit must NOT be connected in this scenario.

Wiring Notes

Ensure if trailer is to be towed by a heavy tow vehicle that connectivity to the in-car controller is tested.

Breakaway systems can be connected to the service break circuit.

04.

Electrical Connection

The Plug and play adapters are wired to function with Elecbrakes and the trailers circuits. No additional wiring is required.

The Elecbrake unit when being hard wired must be connected to the trailers circuits as per the wiring guide (Page 13)

If using the trailer wired leader (TWL) to connect Elecbrakes to the trailers electrical circuits it should be routed to best suit your needs. Connecting to the circuits should be completed by soldering all joins and covering each join with a commercially available shrink tube.

Externally routed cable should be secured every 600mm.

Circuit	Elecbrakes Wire	Trailer Wire	Wire Gauge
Earth	White	White	16-14 awg
Tail lights	Brown	Brown	16-14 awg
Brake lights	Red	Red	16-14 awg
Auxiliary	Black	Black	16-14 awg
Service brake	Blue	Blue	16-14 awg



05.

First Time Setup – Smartphone

Elecbrakes will require the user to setup the ELBC 2000 via the app and their smartphone on the first occasion.

- The app is a friendly interface to setup the naming properties of the unit and brake programs.
- Quick changing between app pages from home screen.
- Settings page allows friendly movement between brake response settings.
- The Technical page provides diagnostic feedback for Elecbrakes and the user.
- The Information page provides the user with Device information to include Software and Firmware versions, serial number and manufacturing date.

If a smartphone is not available for the initial set up, please refer to the Remote User manual for Elecbrakes Remote Control set up option. Please note that renaming properties are not available in setup with remote control.

Smartphone operating requirements

Apple iPhones – IOS 10 on iPhone 5S or better.

Android – Version 5 or better.

App installation

1. Type Elecbrakes into search field.
2. Download Elecbrakes app.
3. Elecbrakes icon will display when loaded correctly.



Connecting Your Smartphone With Elecbrakes

Please activate Headlights to parker or full beam

1. Connect trailer to tow vehicle and connect plug to socket.
2. **Turn on headlights. Do not use auto or daylight selector option.**
3. Launch the Elecbrakes app.

4. The app will open the search screen and display '...LOOKING FOR DEVICE'.



5. Connection Secured System State Button displays grey with a blue tick.



Connecting Your Smartphone With Elecbrakes

Please activate Headlights to parker or full beam

6. Depress brake pedal - system state button displays as bright red.



7. Release foot off brake pedal - System State Button displays grey with a blue tick.

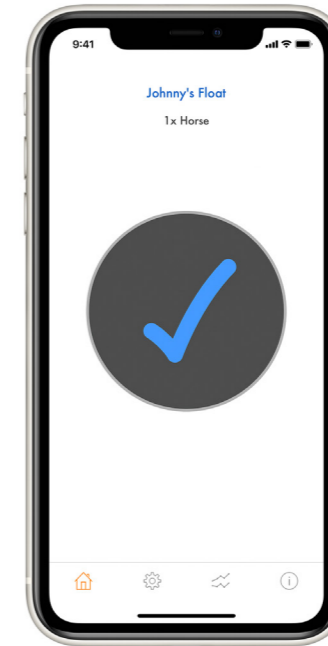

System Check

1. Select the tech page icon at bottom of home screen (next to settings).



2. Headlight Voltage between >10 and <32.

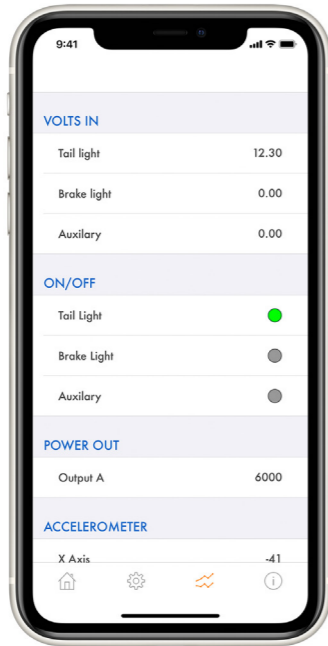

When brake pedal pressed the voltage indicator responds with voltage value.

Note: If Auxiliary power source is connected, voltage input should be displayed and light indicator illuminated.

Set Mounting Angle

Elecbrakes can be mounted facing in any direction (refer mounting orientation) but requires this angle to be confirmed in the unit for operation.

- Connect the trailer and take for a drive. On a straight road increase speed to at least 50 kph and press moderately on the brake pedal for 4-5 seconds.
- The angle the unit is mounted at will be measured, and an installation angle set.
- To confirm installation angle is set go to: Settings Page > Device > Angle After braking the angle should be set between 0-360
- If the angle is not set after the first braking effort, continue braking the tow vehicle and trailer. The Elecbrakes controller will assess each brake response and set the angle for you. This could take 405 brake responses.
- The mounting angle is continuously measured and refined on every application of the brakes.

Installation is now complete.

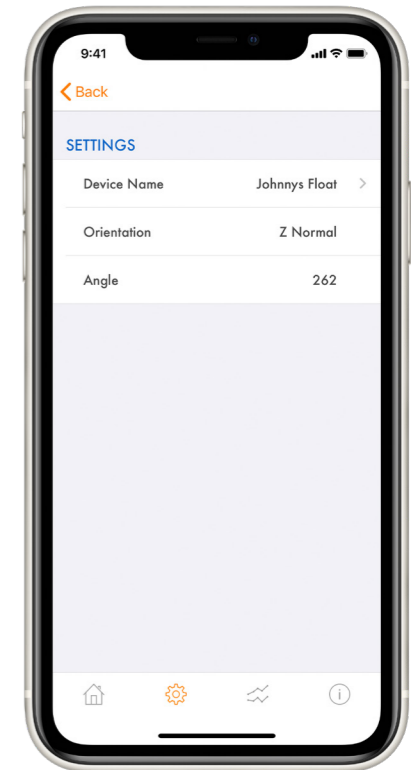

06.

Getting Started

Home screen display

1. **Device name** – user can name the device via settings page e.g. Elecbrakes.
2. **Active program** – displays which of the 5 programs is currently active in ELBC 2000.
3. **Manual override** – allows the user to apply brakes to the trailer only.
4. **System state button** – Displays with blue tick when connected to ELBC2000 and red when braking is being performed
5. **Home icon** – home page displayed.
6. **Settings page** – allows user to rename device, programs, set brake response and set manual override “when tapped value”.
7. **Data page** – provides technical data from the unit.
8. **Info page** – provides manufacturing information, software and firm ware versions and serial number.

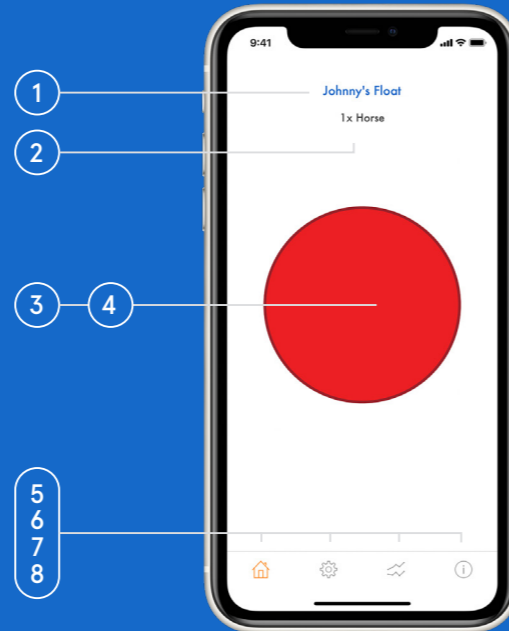

Brake Programs

Elecbrakes has 5 braking programs. All of these are found in the settings page on the app and can be selected by tapping on the name (unknown till changed) to open brake response settings.

Brake programs can be renamed and used to set brake response according to trailer load weight or driving conditions. Elecbrakes programs are default set at various brake response settings. Note: These are a guide only and should be adjusted to suit the load or driving condition that you are using each program for.

First time set up of brake responses should be done via the settings page.

Each Program has 4 brake responses to set up.

1. **Forward Response** – Driving in normal conditions (> 50kmh).
2. **Reverse Response** – Backing trailer in reverse.
3. **Minimum Response** – Driving in normal conditions at slow speed (25kmh).
4. **When Tapped** – Manual Override.

All braking responses are saved in the Elecbrakes unit. When any device connects to the Elecbrakes unit the settings will be displayed on the screen of the in-car controller.

To rename program tap on Name > Unknown and type in new name. When finished tap on done in phone keyboard to save.

Brake Program Setup

- Open program to set brake responses.
- All braking responses are saved in the Elecbrakes unit.
- When any device connects to the Elecbrakes unit the settings will be displayed on the screen of the in-car controller.
- All factory default brake responses are a starting point and must be adjusted at set up to ensure a smooth braking response is applied at the trailer.

Setting Forward Response

1. Tap on Program 1 to open.

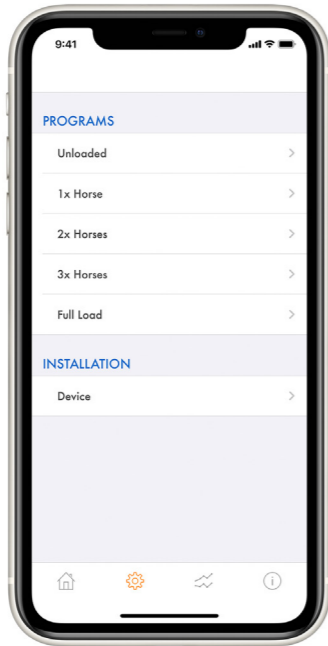

2. Select 'Forward' under Brake Response -Factory set at 40,

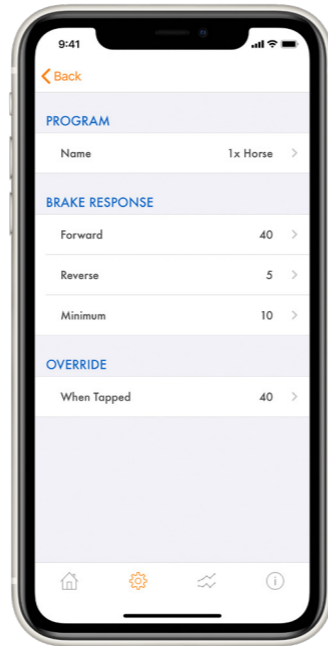

Setting Forward Response

3. When driving at **50kmh apply moderate brake pressure** and assess trailers braking response.



4. Increase or decrease brake response to suit conditions and weight of trailer.
5. Continue adjusting response until satisfied that the trailer is responding correctly.

Elecbrakes recommend adjustments in 5-point increments initially. Finer adjustments can be made to gain a smooth braking response.

Note: Trailer should brake evenly with car in normal driving conditions.

Examples:

- Car Brakes > Trailer Pushes Car > Increase Trailer Brake Response
- Car Brakes > Trailer Pulls Car > Decrease Trailer Brake Response

Setting Minimum Response

1. Select 'Minimum' under Brake Response - factory default is set at 10.

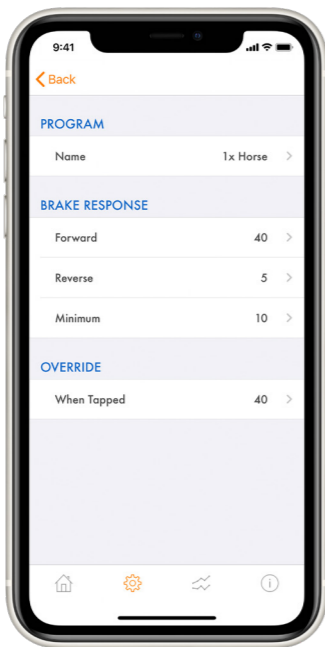

2. When driving at 25kmh apply **light pressure** and assess trailers braking response.

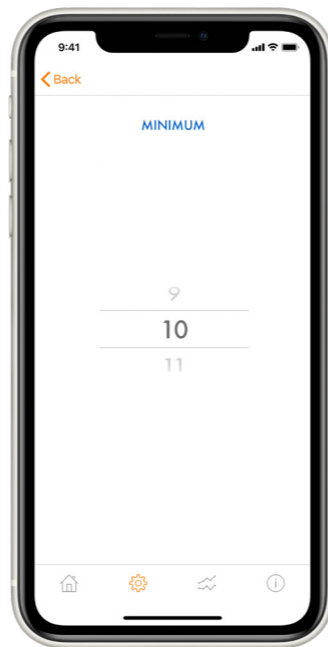

Setting Minimum Response

3. Increase or decrease brake response to suit conditions and weight of trailer.

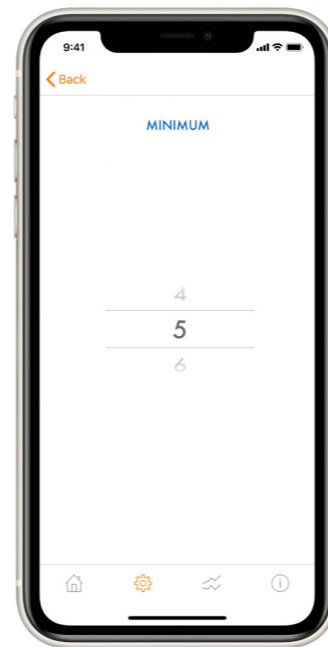

4. Continue adjusting response until satisfied that the trailer is responding correctly.

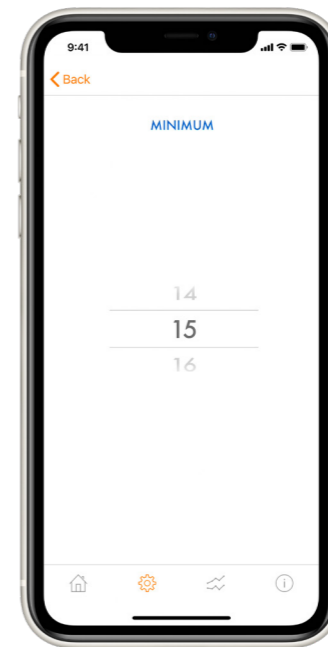

Elecbreaks recommend adjustments in 5-point increments initially. Finer adjustments can be made to gain a smooth braking response.

Note: The Minimum Response should be set up to ensure a smoother braking performance. Poorly adjusted Minimum Response will have the trailer brakes lock up or shudder at low speed.

Example: Driving slow in a town and the brakes lock up.

Setting Reverse Response

1. Select 'Reverse' under Brake Response - factory default is set at 10.

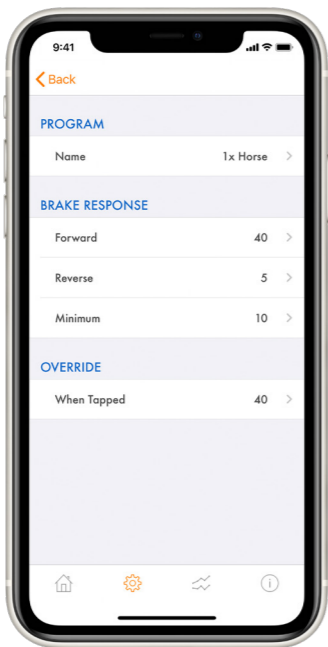

2. When driving slowly in reverse **apply light brake pressure** and assess trailers braking response.



Setting Reverse Response

3. Increase or decrease brake response to suit conditions and weight of trailer.

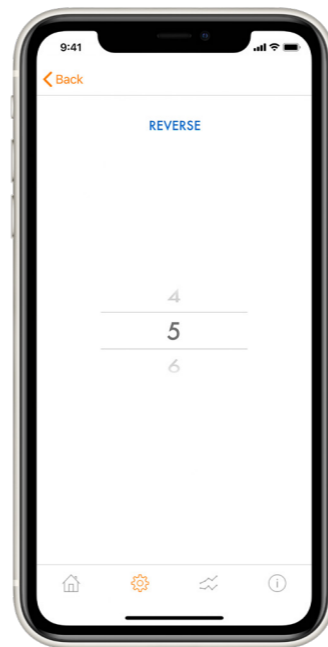

4. Continue adjusting response until satisfied that the trailer is responding correctly.



Elecbreaks recommend adjustments in 5-point increments initially. Finer adjustments can be made to gain a smooth braking response.

When Tapped Response

The When Tapped value is a Manual Override. Activated by tapping on the System State Button on the home screen. This brake response will activate only the trailer brakes at the set value.

1. Select 'When Tapped' under Override in program screen.

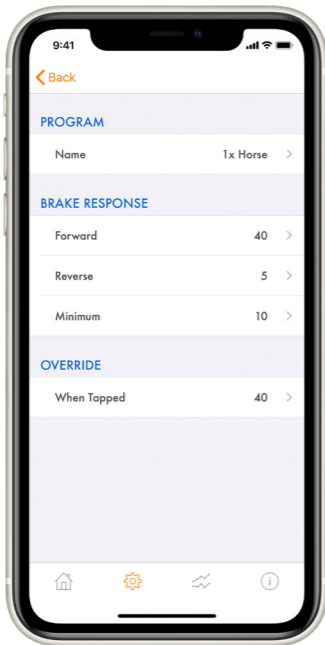

2. Scroll the setting to a higher value than your Forward Response setting. Start at 5% greater.

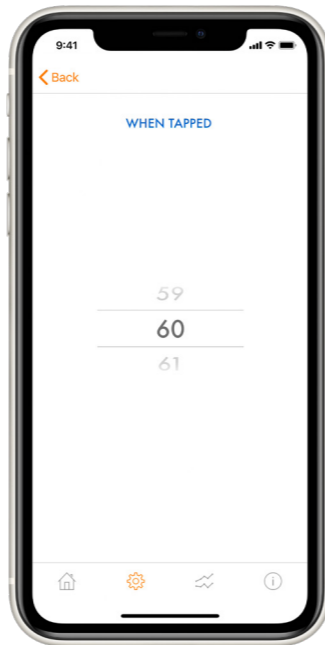

When Tapped Response

3. When driving tap the system state button to activate the manual override - button displays as bright red.

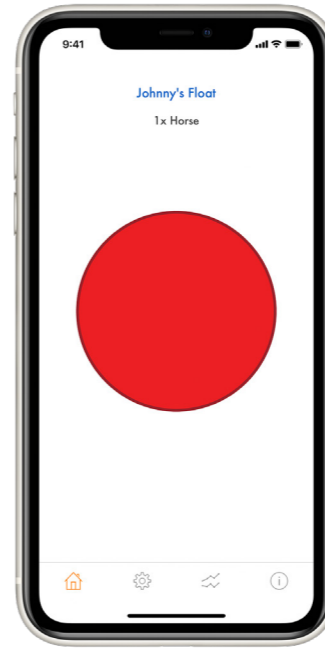

Return to Settings > Device > When Tapped Adjust response until you are satisfied that the brake response will apply the trailer brakes at a level that satisfies your needs.

Note: Typically, the Manual Override would be used when trailer brakes "only" need to be applied. Some scenarios where this may be applicable are:

- To apply brakes to assist in sway control.
- To correct sideways shift of trailer on soft downhill ground. I.e. sand.
- To apply heavier braking on trailer on a steep downhill descent.

Program Change

The braking program can be selected/changed without going to the settings page. To change program:

Home Screen > Swipe Screen Right > Tap Program > Selected is Highlighted

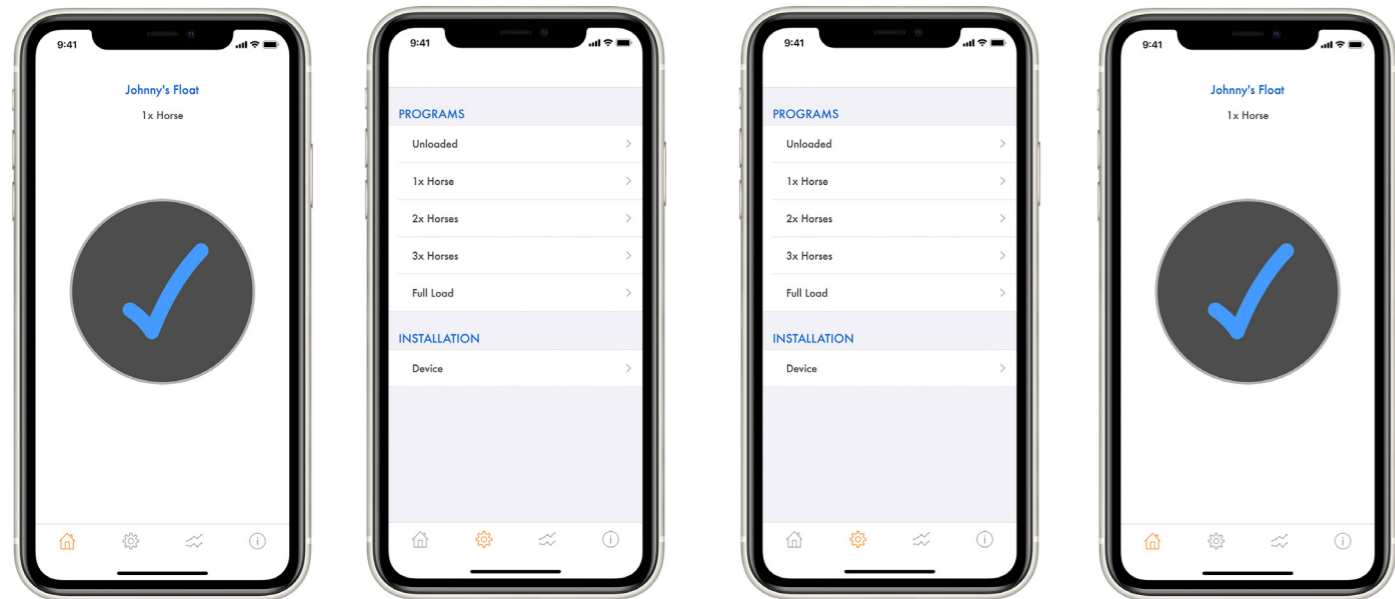

Brake Response Change

Brake response can be increased or decreased without going to settings page. To change brake response:

Home Screen > Swipe Screen Left > Increase or Decrease
Scroll up or down to increase/decrease brake response –
Higher the number the firmer the brake response.

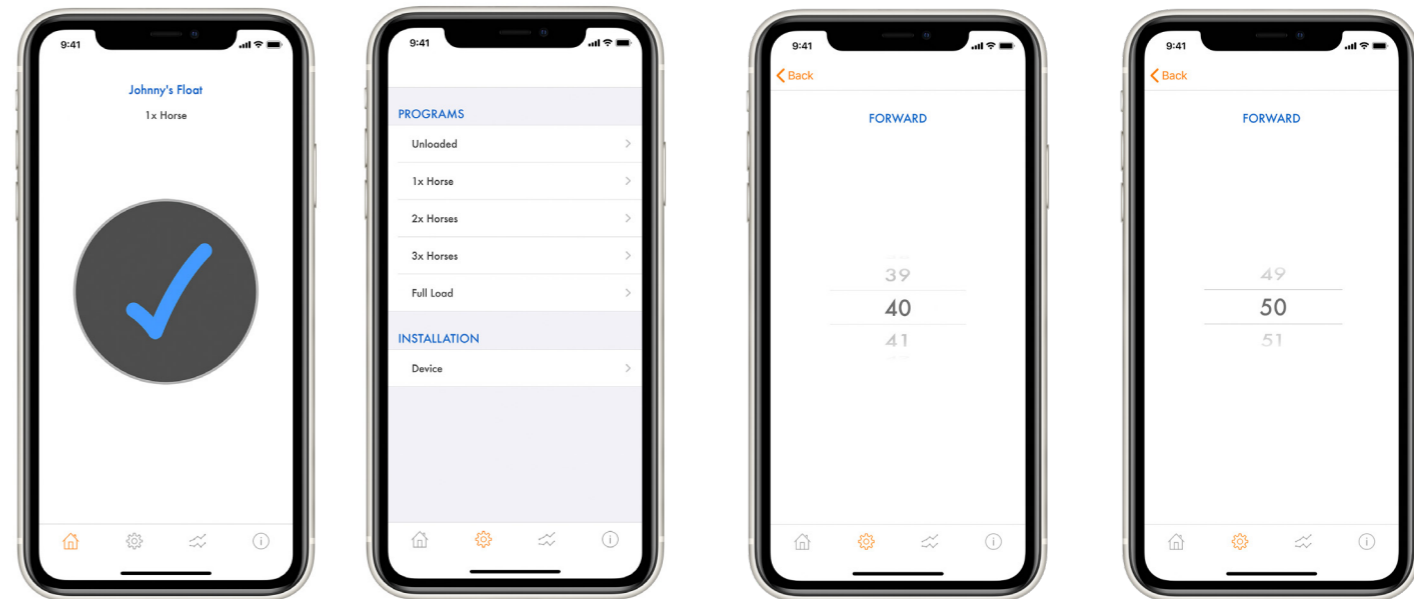

The Forward Response only is changed in the active program in this action. If Minimum Response needs to be changed go to Settings Page > Program > Minimum Response and change the value.



07.

Remote Guide

Remote Interface

1. Display Screen
2. Increase Button
3. Decrease Button
4. Menu Button
5. Manual Override



Active Display Screen

The remote display screen allows the user to identify the active state of the remote.

1. When powered up the screen displays the Elecbrakes logo.



2. Once completing its start up the remote will automatically start to search for a device. The screen will display as searching.



3. When connected to an ELBC 2000 the screen will display a tick and active program will be displayed.



4. When braking in the vehicle the remote will indicate red that the trailer is performing a brake response.



Powering the Remote

- The remote comes with a USB power cable and a 12v socket plug.
- Connect the cable to the USB port on the top edge of the unit.
- The remote can be powered via the car's 12v socket or a USB charging plug.
- The remote will power up automatically as soon as it's connected to power.

Shut Down Mode

- The remote can be shut down by depressing the increase and decrease buttons simultaneously.
- If connected to an ELBC 2000 device and the shutdown feature is activated the remote will disconnect from the device.
- To turn the device back on simply push any button.
- The device will search for and connect to the nearest ELBC 2000 device.
- You can also turn the device off by simply unplugging it and turn it back on by plugging back in.

Sleep Mode

- The ELBC 2000 remote has a sleep mode function. The sleep mode will activate when the unit is not used for 1 minute. The screen will turn off.
- When connected to an ELBC 2000 the remote will not go into sleep mode.

Activating Remote from Sleep Mode

- To wake the remote, press the menu or the increase decrease buttons to open active display.

Selecting Program

- Press Menu Button once to display active program.
- Active program number displayed (1 – 5) in the on-screen display.
- Program name displayed at top of screen.



Change Program

- From the active screen press the menu button.
- Active program displayed.
- Use increase or decrease buttons to scroll through programs.



Display/Change Forward Brake Responses

- Push menu button twice
- Forward response displayed
- Use Increase(+) and Decrease(-) buttons to change brake response

Note: Forward Response should be fine tuned when doing >50km/h and moderately pressing brake pedal.



Display/Change Minimum Response

- Press Menu button 3 times
- Minimum Response displayed
- Use Increase(+) and Decrease(-) buttons to change brake response

Note: Minimum Response should be fine tuned when doing 25kmh and lightly pressing brake pedal

Display/Change Reverse Response

- Press Menu button 4 times
- Reverse Response displayed
- Use Increase(+) and Decrease(-) buttons to change brake response

Manual Override Button

Manual Override allows the driver to apply brake response on the trailer's brakes only.

The Remote has a pressure sensitive button, the harder you press the stronger the brake response.



When you take your finger off the manual override button the brakes will release.

The screen will display as connected.



08.

Troubleshooting Guide

Action	Symptom	Correction
App won't connect.	Power won't connect.	<ul style="list-style-type: none">• Check headlights are on.<ul style="list-style-type: none">- Not auto or day setting.- Go to tech page in app > review Voltage Reads.- Are indicator lights showing green?
	Incorrect start up.	<ul style="list-style-type: none">• Close app, turn lights off.• Turn lights on, reopen app.
	Poor signal.	<ul style="list-style-type: none">• Check where unit is mounted.<ul style="list-style-type: none">- Check installed correctly, not in tool box.• Check plug connections.
Foot on brake pedal applying brakes – brakes lock on trailer.	Power only through brake light circuit.	<ul style="list-style-type: none">• Are head lights on?• Does app connect when brake pedal pressed?<ul style="list-style-type: none">- If so, unit not receiving power from headlight or Auxiliary circuit.- Check wiring circuits at plug.- Check pins in trailer and car plug.
Low speed braking locks trailer brakes up.	Minimum setting incorrect.	<ul style="list-style-type: none">• Go to: Settings > Program > Minimum Response.• Decrease setting go for a drive at 25-30kmh.• Brake and check response.• If OK return to home screen.• If not decrease setting until OK.

Action	Symptom	Correction
Pressing brake pedal has the app disconnect	Indicates a short on the trailers wiring circuit or magnets	<ul style="list-style-type: none"> • Seek auto electrical assistance to determine where the short occurs.
Pressing manual Override has the app disconnect	Indicates a short on the trailers wiring circuit or magnets	<ul style="list-style-type: none"> • Seek auto electrical assistance to determine where the short occurs
Brakes too heavy in reverse.	Brakes jamming on.	<ul style="list-style-type: none"> • Go to: Reverse Response and decrease value. • Continue until brake response is OK.
Load has changed in trailer and brakes not strong enough.	Only 1 program setup.	<ul style="list-style-type: none"> • Go to Settings Page in app. • Set Up additional programs based on weight of load or driving conditions. • Rename each program as per load or condition i.e. empty trailer, max load or steep down hill descent.
Brakes were good, now not strong enough.	New trailer brakes have bed in. Brakes getting hot.	<ul style="list-style-type: none"> • Go to Forward Response and increase value. • Go to Forward Response and increase value. • As brakes cool response value may need to be decreased.

Action	Symptom	Correction
App drops out when driving.	Signal Lost. Adaptor may be disconnected.	<ul style="list-style-type: none"> • App will search for device and reconnect If it does not: • Close app > Turn lights off > Turn lights on > Open app. • Pull over and check adaptor connections.

Modern tow vehicles manage all the electrical circuits. If a short or error is detected in the electrical circuits, or magnets on the trailer the tow vehicle may shut down the circuits to protect the system. If this is the case, power to the Elecbrakes unit is lost and the app or in car remote will disconnect from the device.

This is a normal function of the tow vehicle and Elecbrakes. The trailers Electrical circuits and electrical braking system must be investigated to assess the short or error.

In older vehicles a fuse on the circuit provided the same protection. A blown fuse required investigation and replacement to restore circuit or seek further investigation for fault.



09.

Elecbrakes Product Warranty

Our goods come with guarantees that cannot be excluded under the Australian Consumer Law. You are entitled to a replacement or refund for a major failure and compensation for any other reasonably foreseeable loss or damage. You are also entitled to have the goods repaired or replaced if the goods fail to be of acceptable quality and the failure does not amount to a major failure.

In addition to your rights and remedies at law, all Elecbrakes products are covered by the Elecbrakes Product Warranty. This Product Warranty is provided by:

Elecbrakes Pty Ltd
878 Pacific Highway
Lisarow NSW 2250

Tel: 1300 516 248

Email: warranty@elecbrakes.com

What this Product Warranty covers

Elecbrakes warrants that products will be free from defects in materials and workmanship under normal use (as set out in our product documentation) for a period of 2 years from the original date of purchase ('Warranty Period').

This Product Warranty applies only to products purchased from Elecbrakes or our authorised resellers. This Product Warranty is for the benefit of end consumers only and does not apply if you have purchased a product for resale.

What this Product Warranty does not cover

This Product Warranty applies only to hardware components (and not software components) of products and does not cover defects or damage caused by: (a) normal wear and tear; (b) accidents; (c) neglect; (d) misuse; (e) alterations; (f) incorrect installation, operation or maintenance (including failure to follow product documentation); (g) disassembly or unauthorised repairs; or (h) external forces such as water damage, excessive force; extreme heat, cold or environmental conditions. This Product Warranty does not guarantee that the operation of products will be uninterrupted or error-free.

How to make claim under this Product Warranty

To make a claim under this Product Warranty, you must:

1. contact us by sending an email to <warranty@elecbrakes.com> during the Warranty Period and within 1 month of becoming aware of the defect;
2. provide: (a) your name and contact information; (b) proof of purchase, showing the date and place of purchase from Elecbrakes or our authorised reseller; (c) description of the defect; and (d) any other information we require; and
3. return the product (including all components and accessories) to us by sending it to our nominated address.

Unless we agree otherwise, you are responsible for all costs associated with returning a product to us. We will be responsible for the costs associated with sending you the repaired or replacement product. Products will be at your risk while they are in transit to and from our nominated address.

Elecbrakes may reject claims under this Product Warranty that are not made in accordance with these terms. Nothing in this Product Warranty limits or otherwise affects your statutory rights.

What we will do under this Product Warranty

If we assess that a product returned during the Warranty Period has a defect covered by this Product Warranty, we will at our cost and option: (a) repair the defective product; (b) replace the defective product; or (c) give you a refund of the original purchase price of the defective product.

Defective products may be replaced with equivalent refurbished products. Refurbished parts may be used to repair defective products. Repaired or replaced products will be covered under this Product Warranty for the remainder of the original Warranty Period (replacement or repair does not extend the original Warranty Period). Returned products and parts that have been replaced will become our exclusive property.

If we determine that a returned product is in satisfactory working order, we may require you to: (a) reimburse our reasonable costs of inspecting and testing the product; and (b) pay the costs of returning the product to you.

Additional terms

The provisions of this Product Warranty cannot be modified or extended by Elecbrakes' employees, agents, distributors or resellers or any other person.

If any provision of this Product Warranty is invalid or unenforceable, it must be read down to the point of severance (if necessary) and does not affect the remaining provisions.

To the maximum extent permitted by law, Elecbrakes will not be liable for any failure or delay in meeting its obligations under this Product Warranty to the extent that this is due to circumstances beyond its reasonable control.

The benefits given to you by this Product Warranty are in addition to other rights and remedies you have under law in relation to products to which this Product Warranty relates.

