

USE THE SUPPLIED M2.5 BUTTON HEAD BOLTS TO SECURE THE ROCK RUNNER LOGO TO THE BUMPER IN THE (3) EXISTING HOLES. SECURE TO THE BUMPER USING THE SUPPLIED M2.5 FLAT WASHER, M2.5 LOCK WASHER, AND M2.5 NUT RESPECTIVELY.



**PROPRIETARY AND CONFIDENTIAL**  
 THE INFORMATION CONTAINED IN THIS DRAWING IS THE SOLE PROPERTY OF C4 FABRICATION, LLC. ANY REPRODUCTION IN PART OR AS A WHOLE WITHOUT THE WRITTEN PERMISSION OF C4 FABRICATION, LLC IS PROHIBITED.

MATERIAL

	NAME	DATE
DRAWN	EJK	11/15/23
CHECKED		
ENG APPR.		
MFG APPR.		
Q.A.		
COMMENTS:		

## C4 FABRICATION

TITLE:  
**2016-2023 TACOMA  
 ROCK RUNNER REAR**

SIZE <b>A</b>	DWG. NO.	REV <b>A</b>
------------------	----------	-----------------

DO NOT SCALE DRAWING

SHEET 1 OF 16

2

1

**\*\*OPTIONAL\*\***

IF USING BAJA DESIGNS S1 LIGHTS, SWAP THE FACTORY MOUNTING BRACKET WITH THE SUPPLIED C4 FABRICATION MOUNTING BRACKET IN THE SAME ORIENTATION USING THE FACTORY HARDWARE. USING THE SUPPLIED 5/16" x 3/4" CARRIAGE HEAD BOLT PASS IT THROUGH THE SQUARE HOLE ON THE TOP FACE OF THE BUMPER, THROUGH THE SQUARE HOLE IN THE LIGHT BRACKET AND SECURE USING THE 5/16" FLAT WASHER AND 5/16" FLANGE NUT RESPECTIVELY. REPEAT PROCESS FOR OTHER SIDE. LIGHTS NOT INCLUDED.

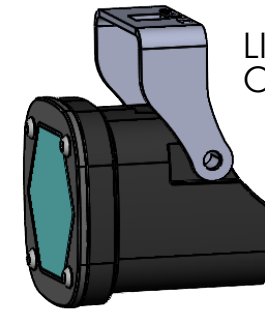

LIGHT BRACKET ORIENTATION

B

B

5/16" x 3/4" CARRIAGE HEAD BOLT

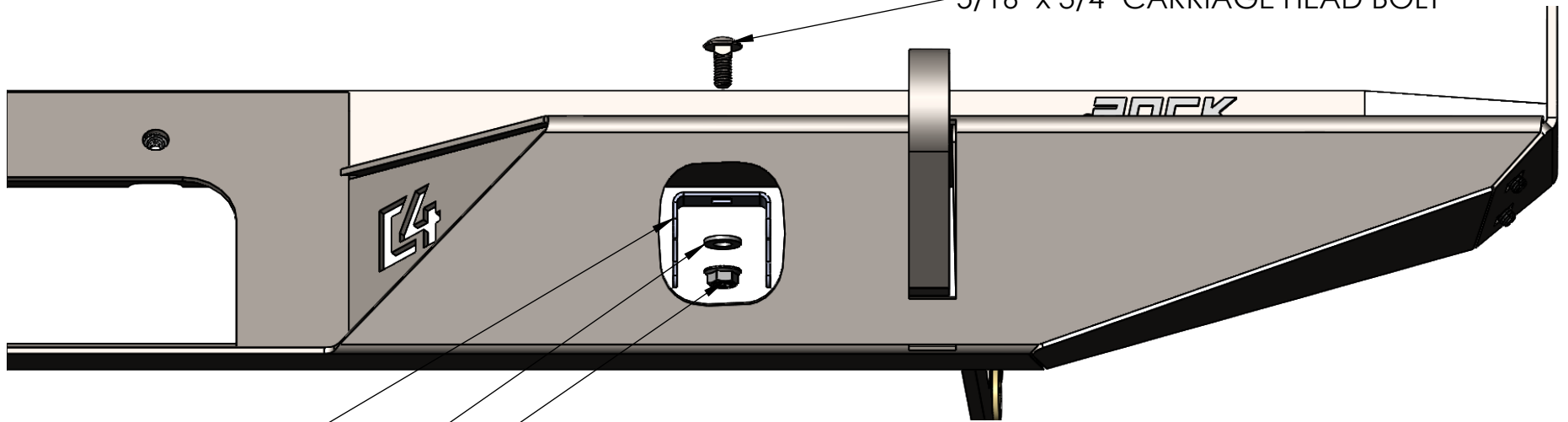

LIGHT BRACKET

5/16" FLAT WASHER

5/16" FLANGE NUT

A

A



**PROPRIETARY AND CONFIDENTIAL**  
THE INFORMATION CONTAINED IN THIS DRAWING IS THE SOLE PROPERTY OF C4 FABRICATION, LLC. ANY REPRODUCTION IN PART OR AS A WHOLE WITHOUT THE WRITTEN PERMISSION OF C4 FABRICATION, LLC IS PROHIBITED.

MATERIAL

	NAME	DATE
DRAWN	EJK	11/15/23
CHECKED		
ENG APPR.		
MFG APPR.		
Q.A.		
COMMENTS:		

### C4 FABRICATION

TITLE:

## 2016-2023 TACOMA ROCK RUNNER REAR

SIZE	DWG. NO.	REV
<b>A</b>		<b>A</b>

DO NOT SCALE DRAWING

SHEET 2 OF 16

2

1

2

1

5/16" x 1/2" BUTTON HEAD BOLT (x2)

5/16" FLAT WASHER (x2)

B

B

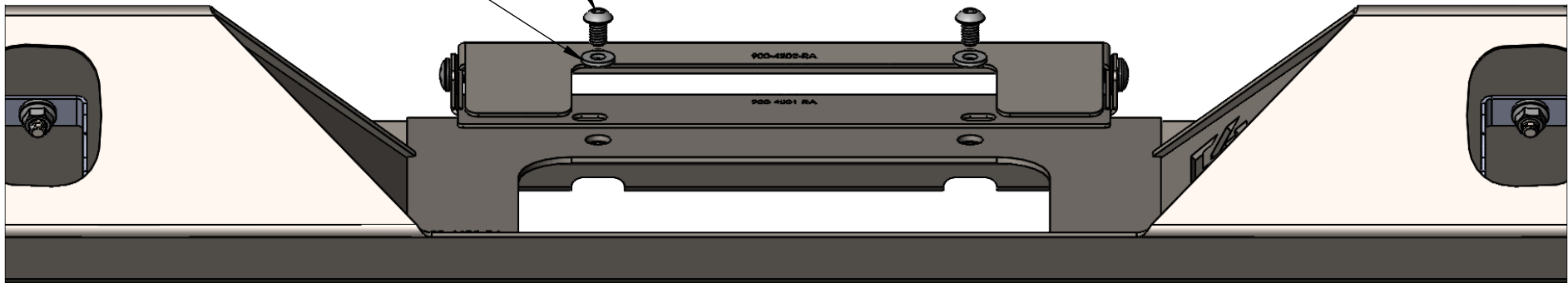

PLEASE REFER TO THE LICENSE PLATE MOUNT BRACKET INSTRUCTIONS TO SHOW HOW TO ASSEMBLE THE FLIP UP BRACKET. ONCE FLIP UP BRACKET IS ASSEMBLED, MOUNT IT TO THE BUMPER AS SHOWN USING THE SUPPLIED 5/16"x1/2" BUTTON HEAD BOLTS AND 1/4" FLAT WASHERS, PASSING THROUGH THE FLIP UP BRACKET AND MOUNTING TO THE WELDED NUTS IN THE BUMPER.

A

A



**PROPRIETARY AND CONFIDENTIAL**  
 THE INFORMATION CONTAINED IN THIS DRAWING IS THE SOLE PROPERTY OF C4 FABRICATION, LLC. ANY REPRODUCTION IN PART OR AS A WHOLE WITHOUT THE WRITTEN PERMISSION OF C4 FABRICATION, LLC IS PROHIBITED.

MATERIAL

	NAME	DATE
DRAWN	11/15/23	EJK
CHECKED		
ENG APPR.		
MFG APPR.		
Q.A.		
COMMENTS:		

### C4 FABRICATION

TITLE:  
**2016-2023 TACOMA  
 ROCK RUNNER REAR**

SIZE <b>A</b>	DWG. NO.	REV <b>A</b>
------------------	----------	-----------------

DO NOT SCALE DRAWING

SHEET 3 OF 16

2

1

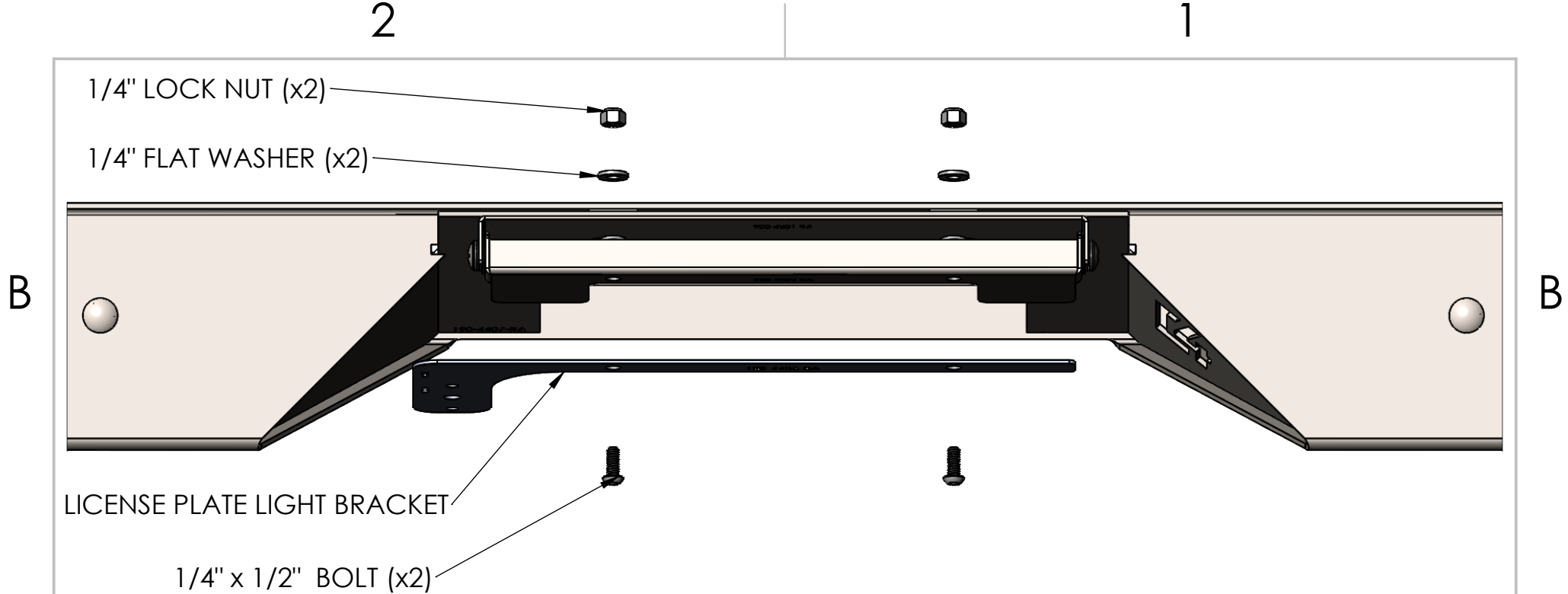

MOUNT THE LICENSE PLATE LIGHT BRACKET TO THE FLIP UP BRACKET USING THE SUPPLIED HARDWARE. FIRST LINE UP THE HOLES OF THE LICENSE PLATE (NOT PICTURED) TO THE HOLES OF THE LIGHT BRACKET AND TO THE HOLES OF THE FLIP UP BRACKET. INSERT THE SUPPLIED 1/4" x 1/2" BOLT THROUGH THE LICENSE PLATE, LICENSE PLATE LIGHT BRACKET AND FLIP UP BRACKET RESPECTIVELY. SECURE USING THE SUPPLIED 1/4" FLAT WASHER AND 1/4" LOCK NUT.

 <p><b>PROPRIETARY AND CONFIDENTIAL</b> THE INFORMATION CONTAINED IN THIS DRAWING IS THE SOLE PROPERTY OF C4 FABRICATION, LLC. ANY REPRODUCTION IN PART OR AS A WHOLE WITHOUT THE WRITTEN PERMISSION OF C4 FABRICATION, LLC IS PROHIBITED.</p> <p>MATERIAL</p>		NAME	DATE	<p><b>C4 FABRICATION</b></p> <p>TITLE: <b>2016-2023 TACOMA ROCK RUNNER REAR</b></p> <p>SIZE <b>A</b>    DWG. NO.    REV <b>A</b></p> <p>DO NOT SCALE DRAWING    SHEET 4 OF 16</p>
	DRAWN	EJK	11/15/23	
	CHECKED			
	ENG APPR.			
	MFG APPR.			
	Q.A.			
	COMMENTS:			

2

1

B

B

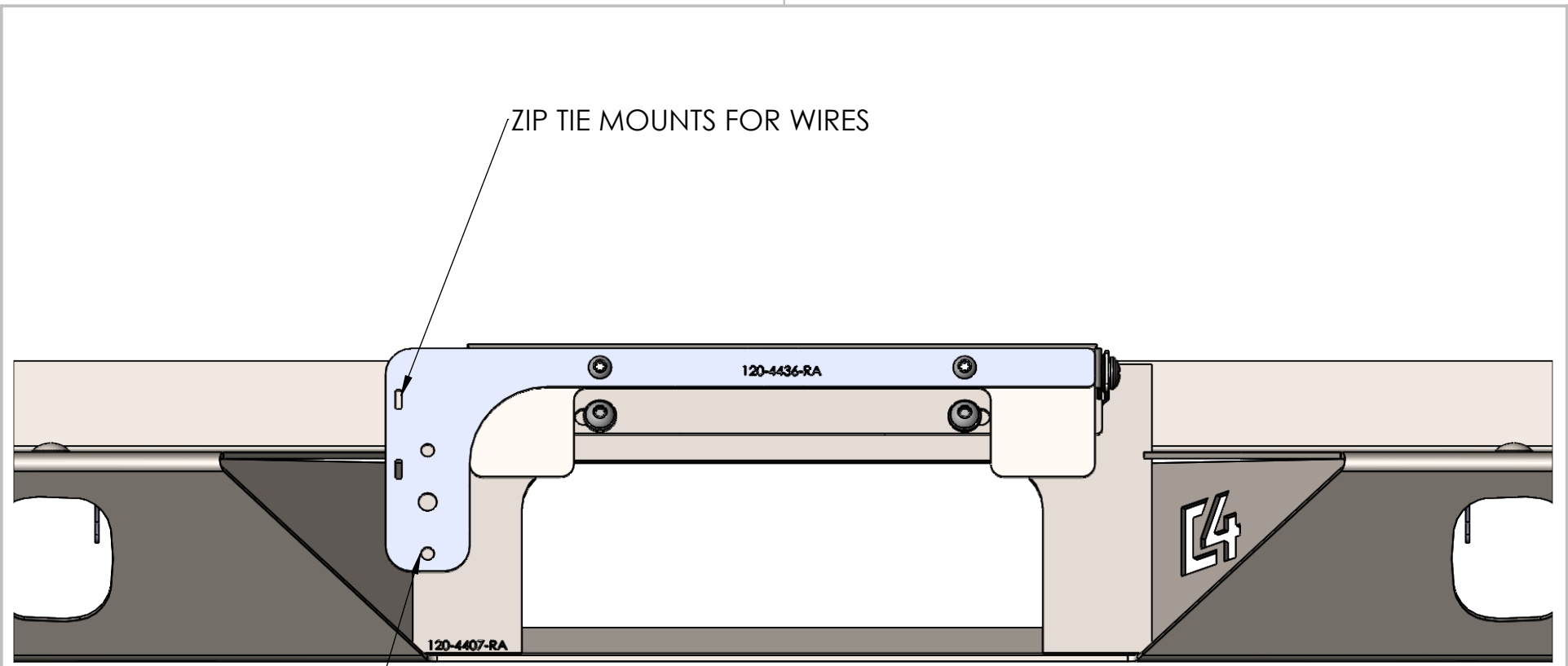

INSTALL LICENSE PLATE LIGHT TO BRACKET USING THE FOLLOWING SUPPLIED HARWARE

- (2) 10-24 x 3/4" OVAL HEAD SCREWS
- (2) #10 FLAT WASHERS
- (2) 10-24 LOCK NUTS

A

A

 <p><b>PROPRIETARY AND CONFIDENTIAL</b> THE INFORMATION CONTAINED IN THIS DRAWING IS THE SOLE PROPERTY OF C4 FABRICATION, LLC. ANY REPRODUCTION IN PART OR AS A WHOLE WITHOUT THE WRITTEN PERMISSION OF C4 FABRICATION, LLC IS PROHIBITED.</p> <p>MATERIAL</p>		NAME	DATE	<h2 style="text-align: center;">C4 FABRICATION</h2>			
	DRAWN	EJK	11/15/23		TITLE:		
	CHECKED				2016-2023 TACOMA ROCK RUNNER REAR		
	ENG APPR.				SIZE	DWG. NO.	REV
	MFG APPR.				<b>A</b>		<b>A</b>
Q.A.				DO NOT SCALE DRAWING			SHEET 5 OF 16
COMMENTS:							

2

1

2

1

B

B

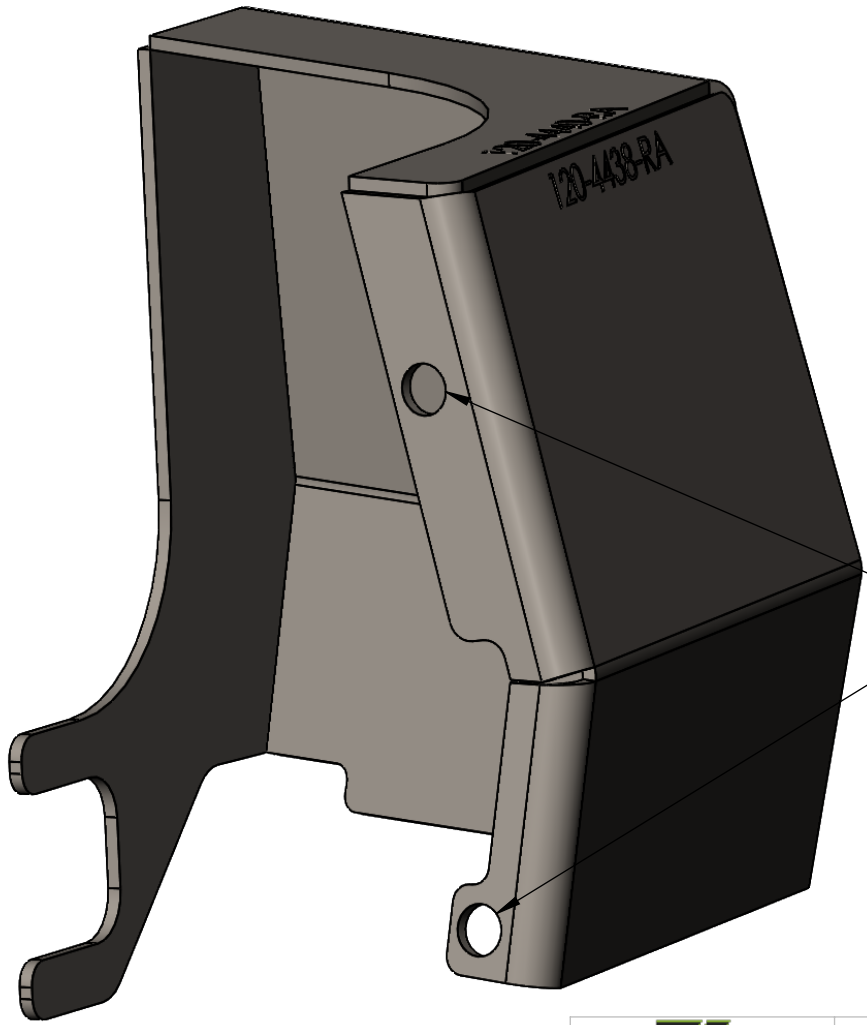

TEST FIT THE BOX CORNERS FOR FITMENT, ONCE IN DESIRED LOCATION MARK THE TWO FRONT HOLES TO BE DRILLED INTO THE BED SIDE. USE A 1/4" DRILL BIT TO DRILL HOLES ONCE THEY ARE MARKED. REPEAT THIS PROCESS FOR BOTH DRIVER AND PASSENGER SIDE.

HOLES TO BE DRILLED INTO BEDSIDE

A

A



**PROPRIETARY AND CONFIDENTIAL**  
 THE INFORMATION CONTAINED IN THIS DRAWING IS THE SOLE PROPERTY OF C4 FABRICATION, LLC. ANY REPRODUCTION IN PART OR AS A WHOLE WITHOUT THE WRITTEN PERMISSION OF C4 FABRICATION, LLC IS PROHIBITED.

MATERIAL

	NAME	DATE
DRAWN	EJK	11/15/23
CHECKED		
ENG APPR.		
MFG APPR.		
Q.A.		
COMMENTS:		

**C4 FABRICATION**

TITLE:  
**2016-2023 TACOMA  
 ROCK RUNNER REAR**

SIZE <b>A</b>	DWG. NO.	REV <b>A</b>
------------------	----------	-----------------

2

1

2

1

B

B

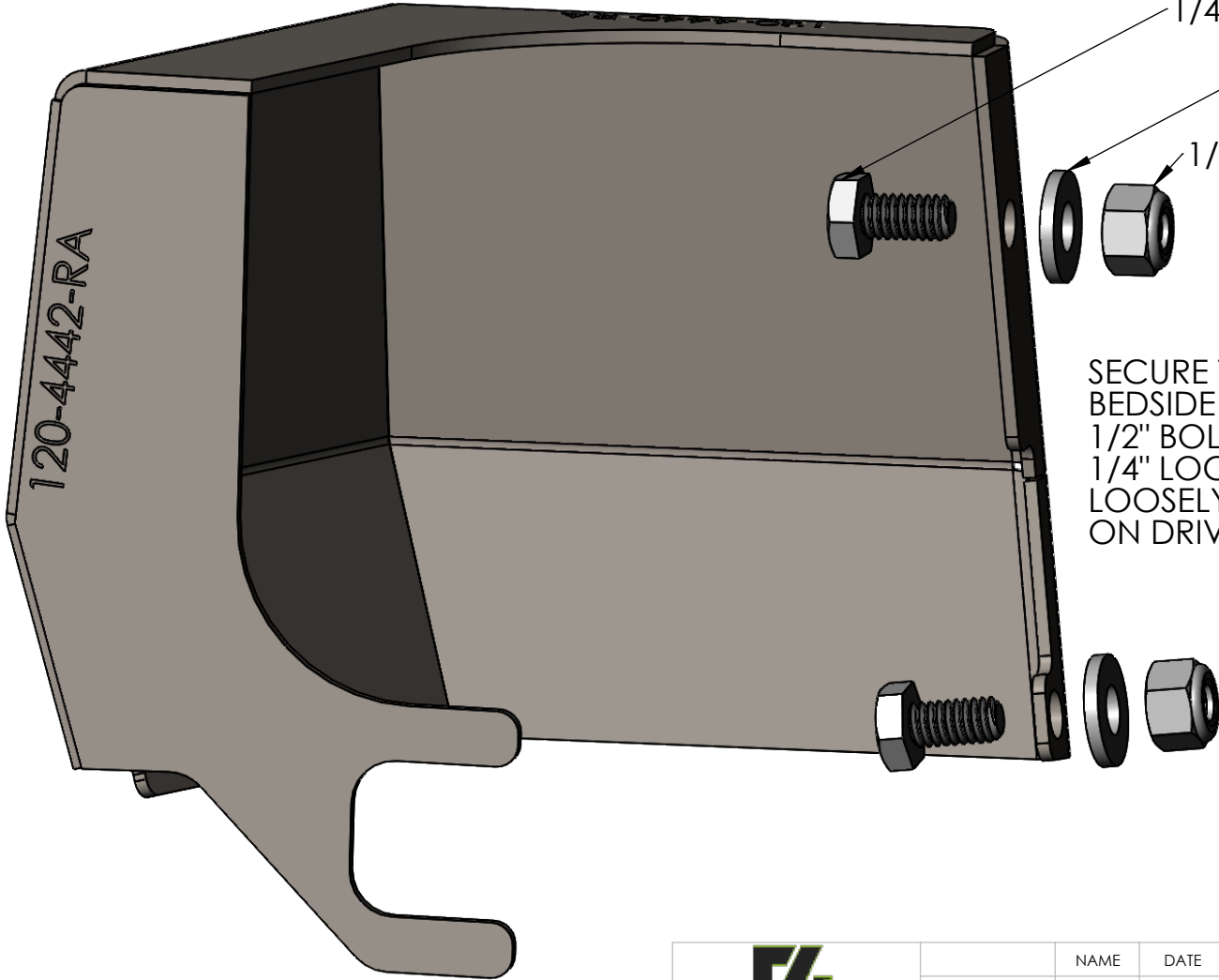

1/4" x 1/2" BOLT (x2)

1/4" FLAT WASHER (x2)

1/4" LOCK NUT (x2)

SECURE THE BOX CORNER TO THE  
BEDSIDE USING THE SUPPLIED 1/4" x  
1/2" BOLT, 1/4" FLAT WASHER, AND  
1/4" LOCK NUT RESPECTIVELY.  
LOOSELY INSTALL FOR NOW, REPEAT  
ON DRIVER / PASSENGER SIDE.

A

A



**PROPRIETARY AND CONFIDENTIAL**  
THE INFORMATION CONTAINED IN  
THIS DRAWING IS THE SOLE  
PROPERTY OF C4 FABRICATION,  
LLC. ANY REPRODUCTION IN PART  
OR AS A WHOLE WITHOUT THE  
WRITTEN PERMISSION OF C4  
FABRICATION, LLC IS PROHIBITED.

MATERIAL

	NAME	DATE
DRAWN	EJK	11/15/23
CHECKED		
ENG APPR.		
MFG APPR.		
Q.A.		
COMMENTS:		

### C4 FABRICATION

TITLE:  
**2016-2023 TACOMA  
ROCK RUNNER REAR**

SIZE <b>A</b>	DWG. NO.	REV <b>A</b>
------------------	----------	-----------------

DO NOT SCALE DRAWING

SHEET 7 OF 16

2

1

2

1

B

B

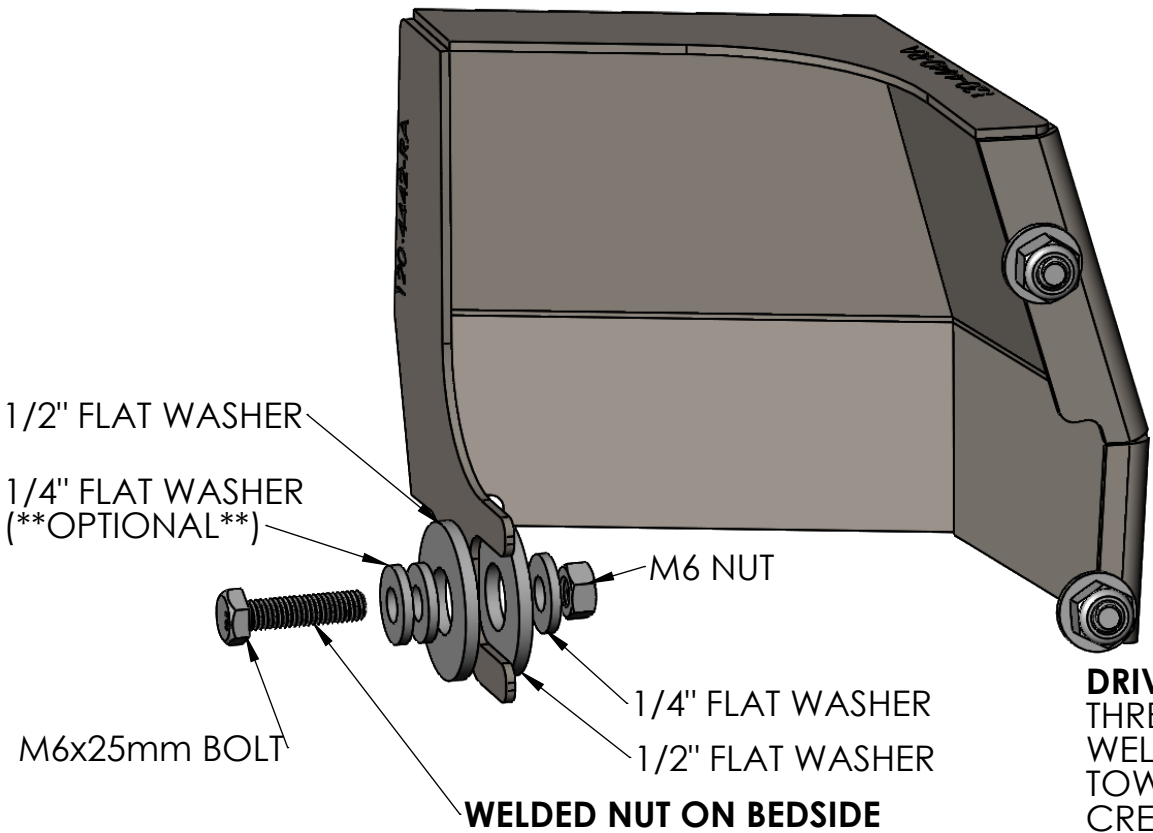

**DRIVER SIDE BOX CORNER**

THREAD THE M6x25mm BOLT THROUGH THE WELDED M6 NUT ON THE BEDSIDE FACING TOWARDS THE DRIVER SIDE OF THE PICKUP CREATING A STUD. USE THE 1/4" FLAT WASHERS AS NEEDED TO SPACE THE BOX CORNER FOR AN EVEN REVEAL. PLACE THE 1/2" FLAT WASHER ON EITHER SIDE OF THE MOUNT, 1/4" FLAT WASHER, AND M6 NUT RESPECTIVELY. TORQUE ALL HARDWARE TO 15 FT-LBS.

A

A

**\*\*OPTIONAL\*\***  
USE EXTRA PROVIDED WASHERS SHOWN ABOVE FOR DESIRED FITMENT REVEAL.



**PROPRIETARY AND CONFIDENTIAL**  
THE INFORMATION CONTAINED IN THIS DRAWING IS THE SOLE PROPERTY OF C4 FABRICATION, LLC. ANY REPRODUCTION IN PART OR AS A WHOLE WITHOUT THE WRITTEN PERMISSION OF C4 FABRICATION, LLC IS PROHIBITED.

MATERIAL

	NAME	DATE
DRAWN	EJK	11/15/23
CHECKED		
ENG APPR.		
MFG APPR.		
Q.A.		
COMMENTS:		

**C4 FABRICATION**

TITLE:  
**2016-2023 TACOMA  
ROCK RUNNER REAR**

SIZE <b>A</b>	DWG. NO.	REV <b>A</b>
------------------	----------	-----------------

DO NOT SCALE DRAWING

SHEET 8 OF 16

2

1



2

1

### PASSENGER SIDE BOX CORNER

REMOVE THE FACTORY M10 NUT NEAR THE PASSENGER SIDE BOX CORNER. ADD A 1/2" FLAT WASHER ON BOTH SIDES OF THE MOUNTING BRACKET, FOLLOWED BY 3/8" FLAT WASHERS AS NEEDED TO GET AN EVEN REVEAL. TORQUE ALL HARDWARE TO 15 FT-LBS.

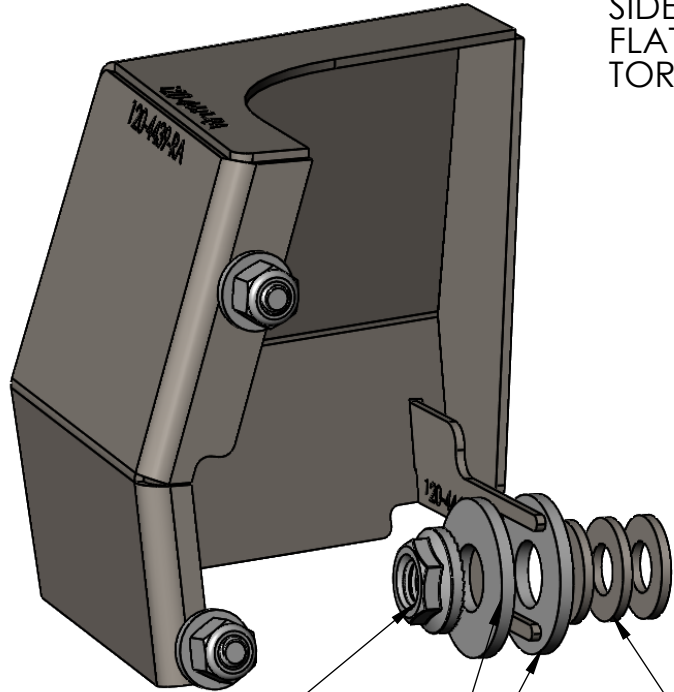

FACTORY M10 NUT

1/2" FLAT WASHER (\*\*OPTIONAL\*\*)

3/8" FLAT WASHER (x3) (\*\*OPTIONAL\*\*)

**\*\*OPTIONAL\*\***  
USE EXTRA PROVIDED WASHERS SHOWN ABOVE FOR DESIRED FITMENT REVEAL.



**PROPRIETARY AND CONFIDENTIAL**  
THE INFORMATION CONTAINED IN THIS DRAWING IS THE SOLE PROPERTY OF C4 FABRICATION, LLC. ANY REPRODUCTION IN PART OR AS A WHOLE WITHOUT THE WRITTEN PERMISSION OF C4 FABRICATION, LLC IS PROHIBITED.

MATERIAL

	NAME	DATE
DRAWN	EJK	11/15/23
CHECKED		
ENG APPR.		
MFG APPR.		
Q.A.		
COMMENTS:		

## C4 FABRICATION

TITLE:

# 2016-2023 TACOMA ROCK RUNNER REAR

SIZE	DWG. NO.	REV
<b>A</b>		<b>A</b>

DO NOT SCALE DRAWING

SHEET 9 OF 16

2

1

B

B

A

A

2

1

# PLATE SIDE INSTALL INSTRUCTIONS

B

B

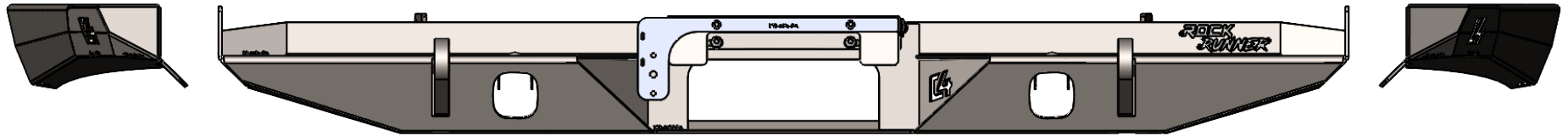

A

A

 <b>PROPRIETARY AND CONFIDENTIAL</b> THE INFORMATION CONTAINED IN THIS DRAWING IS THE SOLE PROPERTY OF C4 FABRICATION, LLC. ANY REPRODUCTION IN PART OR AS A WHOLE WITHOUT THE WRITTEN PERMISSION OF C4 FABRICATION, LLC IS PROHIBITED. MATERIAL		NAME	DATE	<b>C4 FABRICATION</b>		
	DRAWN	EJK	11/15/23		TITLE:	
	CHECKED			2016-2023 TACOMA ROCK RUNNER REAR		
	ENG APPR.					
	MFG APPR.					
	Q.A.			SIZE	DWG. NO.	REV
	COMMENTS:			<b>A</b>		<b>A</b>
				DO NOT SCALE DRAWING		SHEET 10 OF 16

2

1

2 1

B

B

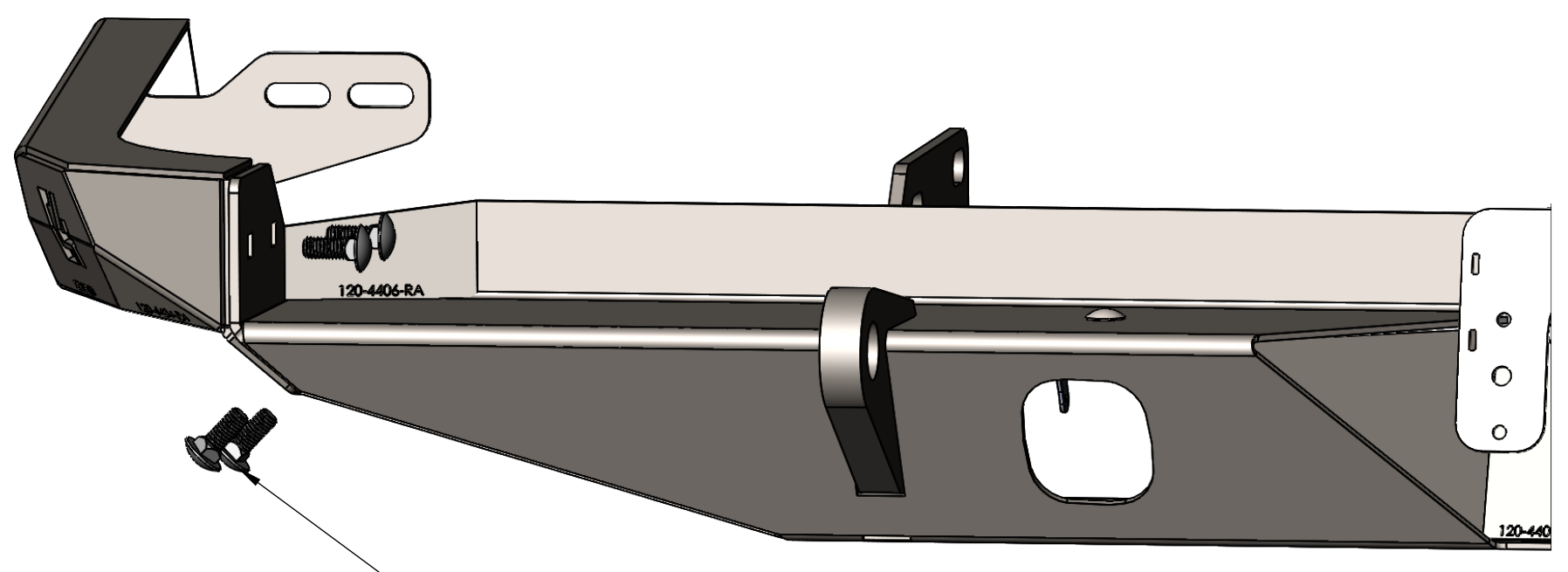

3/8" x 1" CARRIAGE HEAD BOLT (x4)

INSERT THE (4) 3/8" x 1" CARRIAGE HEAD BOLTS AS SHOWN INTO SIDE WING

A

A

 <p><b>PROPRIETARY AND CONFIDENTIAL</b> THE INFORMATION CONTAINED IN THIS DRAWING IS THE SOLE PROPERTY OF C4 FABRICATION, LLC. ANY REPRODUCTION IN PART OR AS A WHOLE WITHOUT THE WRITTEN PERMISSION OF C4 FABRICATION, LLC IS PROHIBITED.</p> <p>MATERIAL</p>		NAME	DATE	<p><b>C4 FABRICATION</b></p> <p>TITLE: <b>2016-2023 TACOMA ROCK RUNNER REAR</b></p> <p>SIZE <b>A</b> DWG. NO. REV <b>A</b></p> <p>DO NOT SCALE DRAWING SHEET 11 OF 16</p>
	DRAWN	EJK	11/15/23	
	CHECKED			
	ENG APPR.			
	MFG APPR.			
	COMMENTS:			

2

1

2

1

B

B

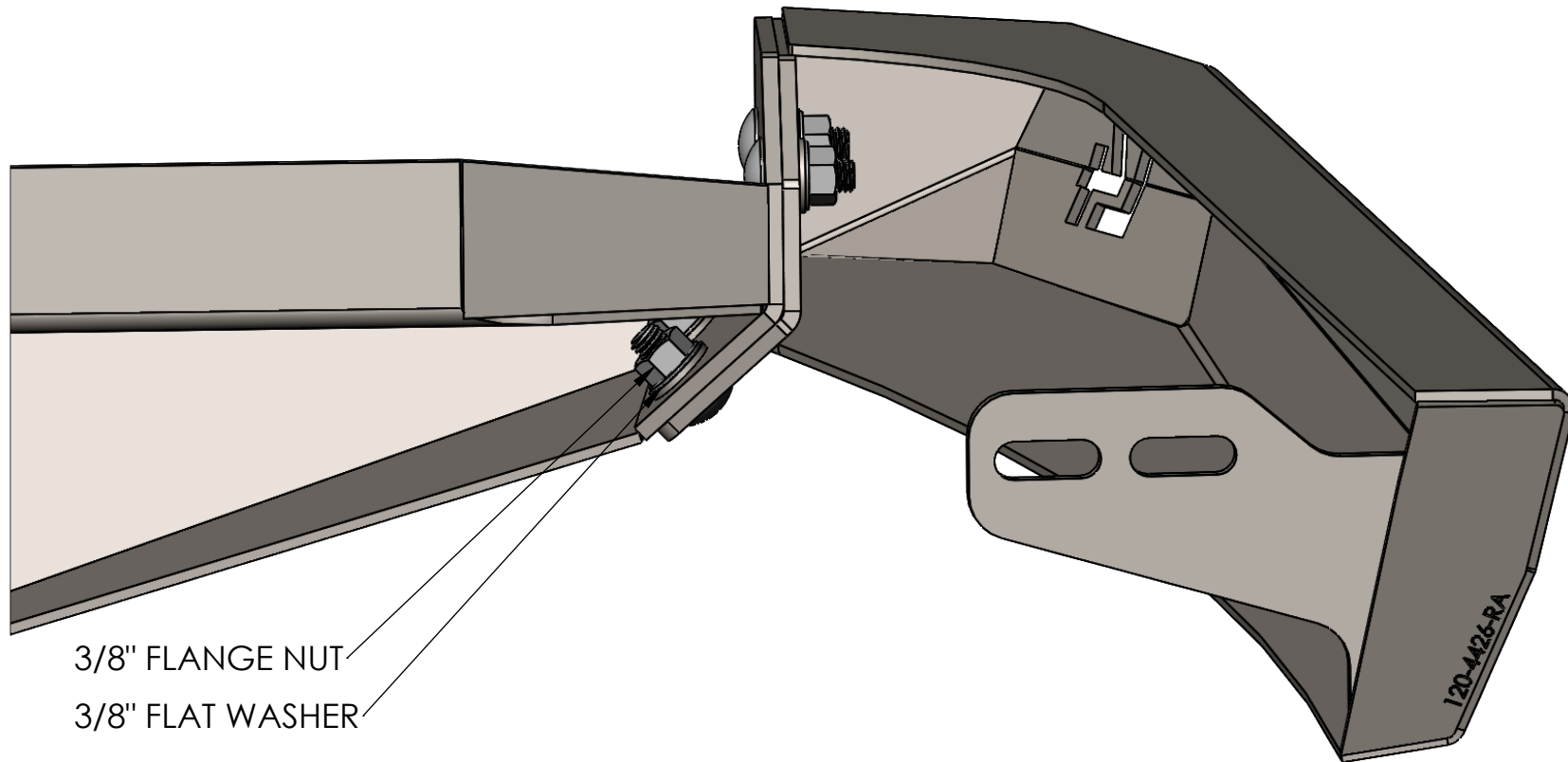

3/8" FLANGE NUT

3/8" FLAT WASHER

120-4426-RA

NOW THAT THE CARRIAGE BOLTS AND SIDE WING ARE IN PLACE, SECURE USING THE SUPPLIED 3/8" FLAT WASHER AND 3/8" FLANGE NUT RESPECTIVELY. LOOSELY TIGHTEN AND REPEAT ON DRIVER/ PASSENGER SIDE WING. FLIP BUMPER OVER TO ENSURE BOTH ARE FLAT, THEN TORQUE ALL (8) NUTS TO 45 FT-LBS.

A

A



**PROPRIETARY AND CONFIDENTIAL**  
 THE INFORMATION CONTAINED IN THIS DRAWING IS THE SOLE PROPERTY OF C4 FABRICATION, LLC. ANY REPRODUCTION IN PART OR AS A WHOLE WITHOUT THE WRITTEN PERMISSION OF C4 FABRICATION, LLC IS PROHIBITED.

MATERIAL

	NAME	DATE
DRAWN	EJK	11/15/23
CHECKED		
ENG APPR.		
MFG APPR.		
Q.A.		
COMMENTS:		

### C4 FABRICATION

TITLE:  
**2016-2023 TACOMA  
 ROCK RUNNER REAR**

SIZE <b>A</b>	DWG. NO.	REV <b>A</b>
------------------	----------	-----------------

DO NOT SCALE DRAWING

SHEET 12 OF 16

2

1

2

1

# TUBE SIDE INSTALL INSTRUCTIONS

B

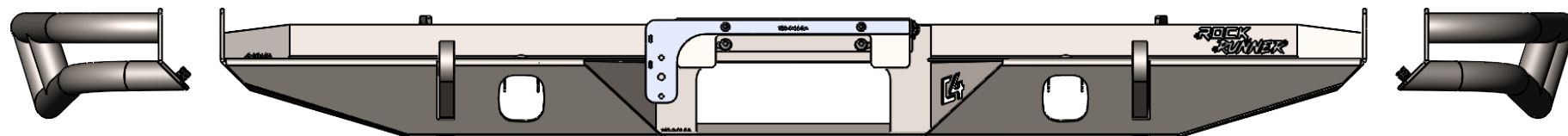

B

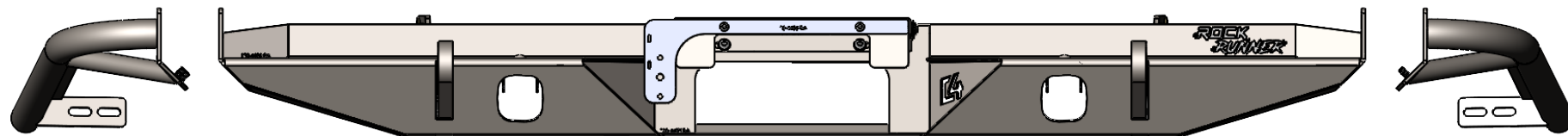

A

 <p><b>PROPRIETARY AND CONFIDENTIAL</b> THE INFORMATION CONTAINED IN THIS DRAWING IS THE SOLE PROPERTY OF C4 FABRICATION, LLC. ANY REPRODUCTION IN PART OR AS A WHOLE WITHOUT THE WRITTEN PERMISSION OF C4 FABRICATION, LLC IS PROHIBITED.</p> <p>MATERIAL</p>		NAME	DATE	<p><b>C4 FABRICATION</b></p> <p>TITLE: <b>2016-2023 TACOMA ROCK RUNNER REAR</b></p>
	DRAWN	EJK	11/15/23	
	CHECKED			
	ENG APPR.			
	MFG APPR.			<p>SIZE <b>A</b></p> <p>DO NOT SCALE DRAWING</p>
		Q.A.		
	COMMENTS:			

A

2

1

2

1

3/8" FLAT WASHER (x2)

USING SUPPLIED 3/8" x 1" FLANGE BOLTS AND 3/8" FLAT WASHERS RESPECTIVELY, SECURE THE SIDE WING TO THE BUMPER BY THREADING BOLTS WITH WASHER TO THE TWO WELDED NUTS ON THE SIDE WING.

B

B

3/8" x 1" FLANGE BOLT (x2)

USING THE SUPPLIED 5/16" FLANGE NUT AND 5/16" FLAT WASHER RESPECTIVELY, SECURE TO THE WELDED STUDS ON THE LOWER HALF OF THE SIDE WING.

REPEAT PROCESS FOR DRIVER/ PASSENGER SIDE. MAKE SURE BOTH SIDES ARE EVEN, THEN TORQUE TO 45 FT-LBS.

5/16" FLAT WASHER (x2)

5/16" FLANGE NUT (x2)

A

A



PROPRIETARY AND CONFIDENTIAL  
THE INFORMATION CONTAINED IN THIS DRAWING IS THE SOLE PROPERTY OF C4 FABRICATION, LLC. ANY REPRODUCTION IN PART OR AS A WHOLE WITHOUT THE WRITTEN PERMISSION OF C4 FABRICATION, LLC IS PROHIBITED.

MATERIAL

	NAME	DATE
DRAWN	EJK	11/15/23
CHECKED		
ENG APPR.		
MFG APPR.		
Q.A.		
COMMENTS:		

### C4 FABRICATION

TITLE:  
2016-2023 TACOMA  
ROCK RUNNER REAR

SIZE <b>A</b>	DWG. NO.	REV <b>A</b>
------------------	----------	-----------------

2

1

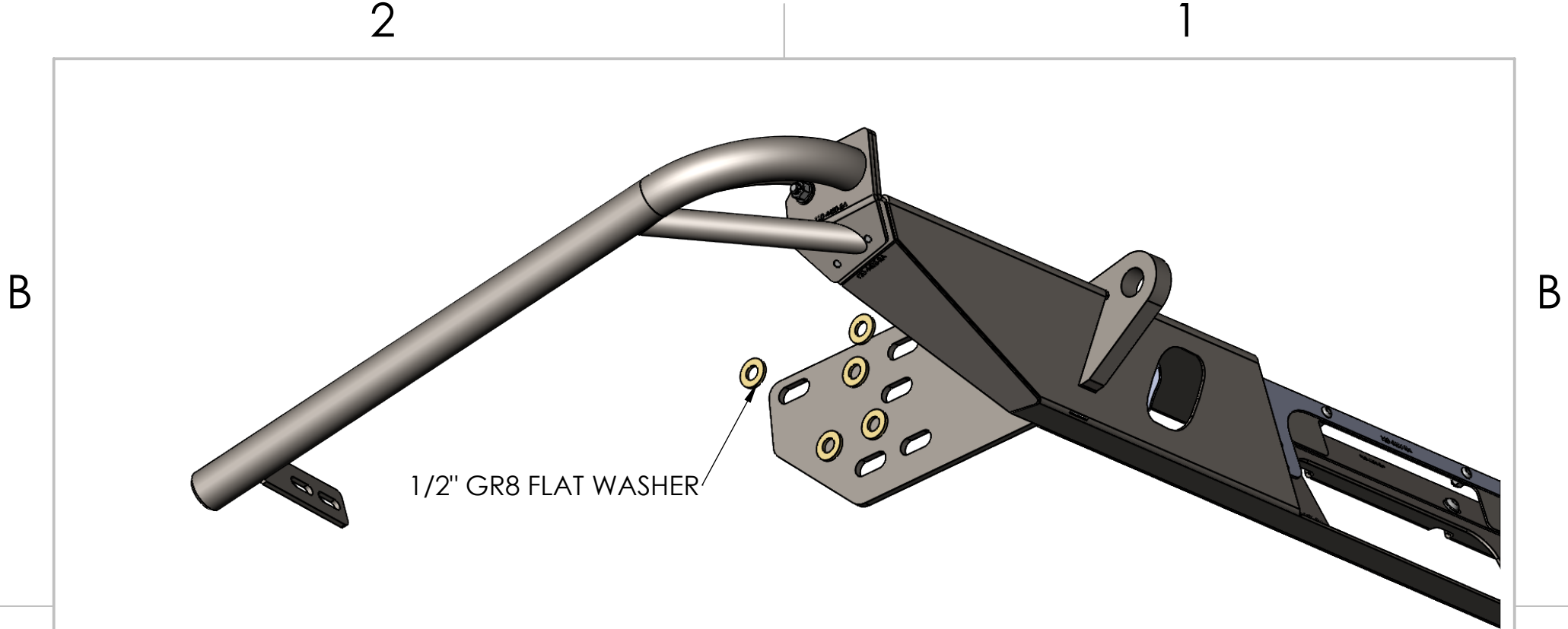

AFTER THE BEDSIDEDS HAVE BEEN TRIMMED. MOUNT THE BUMPER TO THE PICKUP USING THE SUPPLIED 1/2" GRADE 8 FLAT WASHERS AND FACTORY M12 BOLTS. ADJUST BUMPER IN SLOTS TO GET DESIRED FITMENT. TORQUE TO 65 FT-LBS ON BOTH DRIVER AND PASSENGER SIDE.

 <b>PROPRIETARY AND CONFIDENTIAL</b> THE INFORMATION CONTAINED IN THIS DRAWING IS THE SOLE PROPERTY OF C4 FABRICATION, LLC. ANY REPRODUCTION IN PART OR AS A WHOLE WITHOUT THE WRITTEN PERMISSION OF C4 FABRICATION, LLC IS PROHIBITED. MATERIAL		NAME	DATE	<b>C4 FABRICATION</b> TITLE: <b>2016-2023 TACOMA          ROCK RUNNER REAR</b>
	DRAWN	EJK	11/15/23	
	CHECKED			
	ENG APPR.			
	MFG APPR.			
	Q.A.			
	COMMENTS:			
	SIZE	DWG. NO.		REV
	<b>A</b>			<b>A</b>
DO NOT SCALE DRAWING			SHEET 15 OF 16	

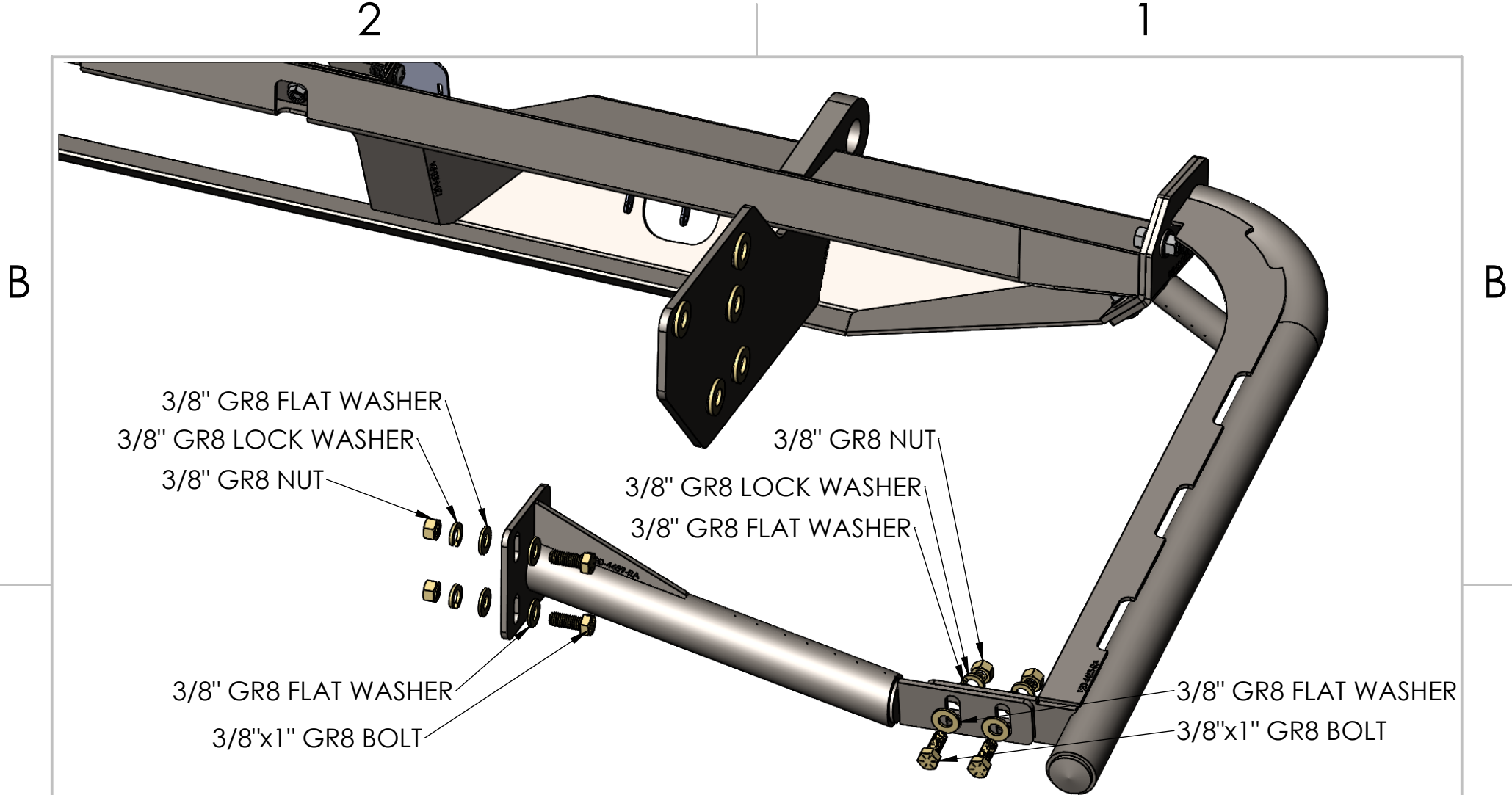

AFTER INSTALLING THE BUMPER ONTO THE PICKUP, TEST FIT THE SIDE SUPPORT BRACE TO THE MOUNTING TAB AND FRAME OF THE PICKUP. THE SLOTTED HOLES ON THE SUPPORT THAT MOUNTS TO THE FRAME SHOULD BE TOWARDS THE FRONT OF THE PICKUP. MARK HOLES ONCE POSITIONED CORRECTLY. DRILL USING A 3/8" DRILL BIT. SECURE TO BUMPER AND FRAME USING GRADE 8 HARDWARE AS SHOWN. TORQUE ALL HARDWARE TO 50 FT-LBS. REPEAT FOR DRIVER/ PASSENGER SIDE.

**C4 FABRICATION**

PROPRIETARY AND CONFIDENTIAL  
 THE INFORMATION CONTAINED IN THIS DRAWING IS THE SOLE PROPERTY OF C4 FABRICATION, LLC. ANY REPRODUCTION IN PART OR AS A WHOLE WITHOUT THE WRITTEN PERMISSION OF C4 FABRICATION, LLC IS PROHIBITED.

MATERIAL

	NAME	DATE
DRAWN	EJK	11/15/23
CHECKED		
ENG APPR.		
MFG APPR.		
Q.A.		
COMMENTS:		

<b>C4 FABRICATION</b>		
TITLE: 2016-2023 TACOMA ROCK RUNNER REAR		
SIZE <b>A</b>	DWG. NO.	REV <b>A</b>
DO NOT SCALE DRAWING		SHEET 16 OF 16