

2

1

B

B

FIRST START WITH THE BUMPER CENTER, THE DRIVER SIDE WING, AND PASSENGER SIDE WING

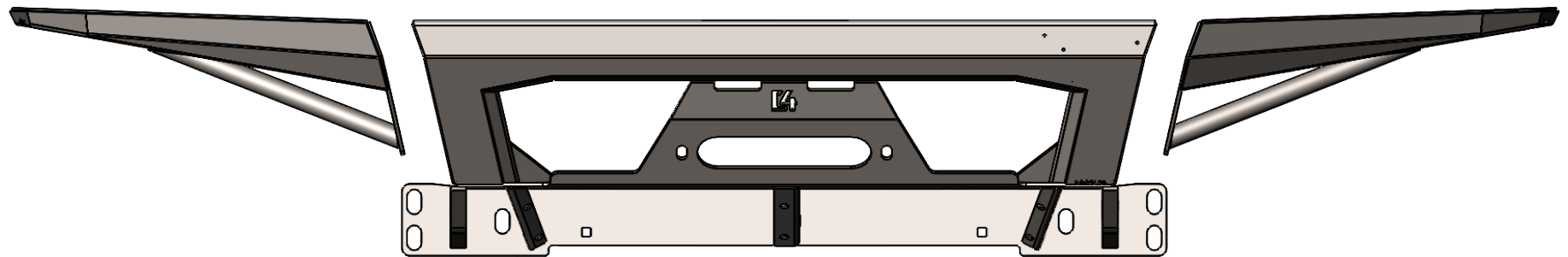

A

A



PROPRIETARY AND CONFIDENTIAL
 THE INFORMATION CONTAINED IN THIS DRAWING IS THE SOLE PROPERTY OF C4 FABRICATION, LLC. ANY REPRODUCTION IN PART OR AS A WHOLE WITHOUT THE WRITTEN PERMISSION OF C4 FABRICATION, LLC IS PROHIBITED.

MATERIAL

	NAME	DATE
DRAWN	EJK	11/1/23
CHECKED		
ENG APPR.		
MFG APPR.		
Q.A.		

COMMENTS:

C4 FABRICATION

TITLE:

**2016-2023 TACOMA
ROCK RUNNER FRONT**

SIZE

A

DWG. NO.

REV

A

DO NOT SCALE DRAWING

SHEET 1 OF 15

2

1

2

1

PLATE SIDE WING

LINE UP FRONT AND TOP FACES OF SIDE WING TO BE FLUSH WITH BUMPER CENTER SECTION

B

B

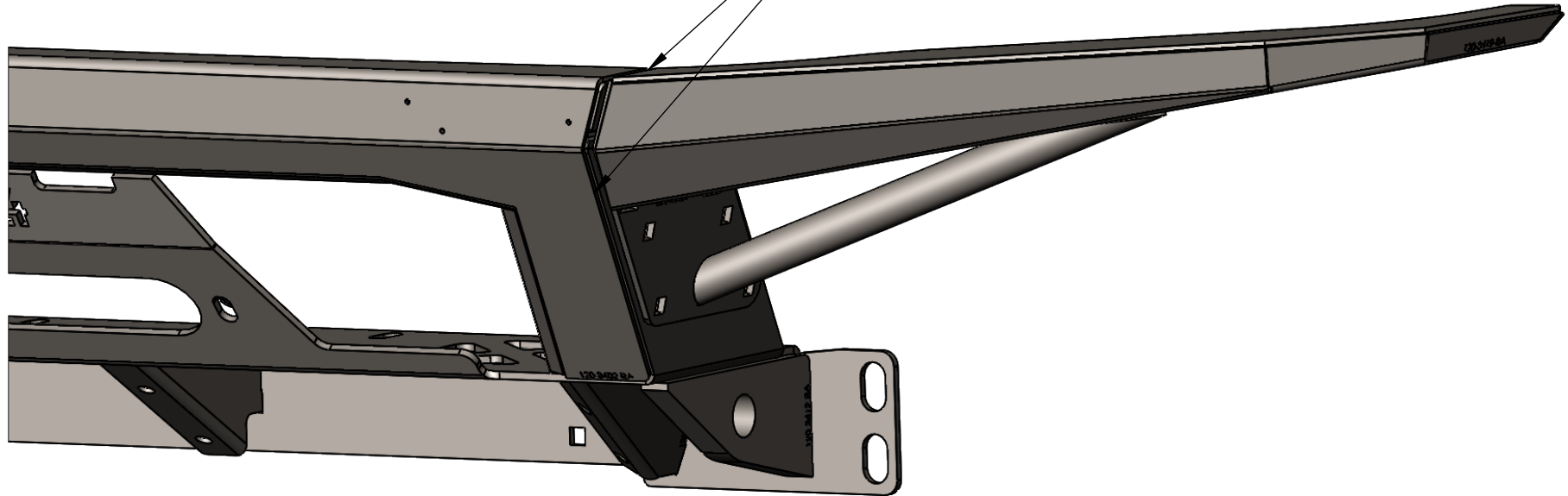

A

A



PROPRIETARY AND CONFIDENTIAL
 THE INFORMATION CONTAINED IN THIS DRAWING IS THE SOLE PROPERTY OF C4 FABRICATION, LLC. ANY REPRODUCTION IN PART OR AS A WHOLE WITHOUT THE WRITTEN PERMISSION OF C4 FABRICATION, LLC IS PROHIBITED.

MATERIAL

	NAME	DATE
DRAWN	EJK	11/1/23
CHECKED		
ENG APPR.		
MFG APPR.		
Q.A.		
COMMENTS:		

C4 FABRICATION

TITLE:
**2016-2023 TACOMA
 ROCK RUNNER FRONT**

SIZE A	DWG. NO.	REV A
------------------	----------	-----------------

DO NOT SCALE DRAWING

SHEET 2 OF 15

2

1

2

1

PLATE SIDE WING

- 3/8" FLANGE NUT (x4)
- 3/8" FLAT WASHER (x4)
- 3/8"x1" CARRIAGE HEAD BOLT (x4)

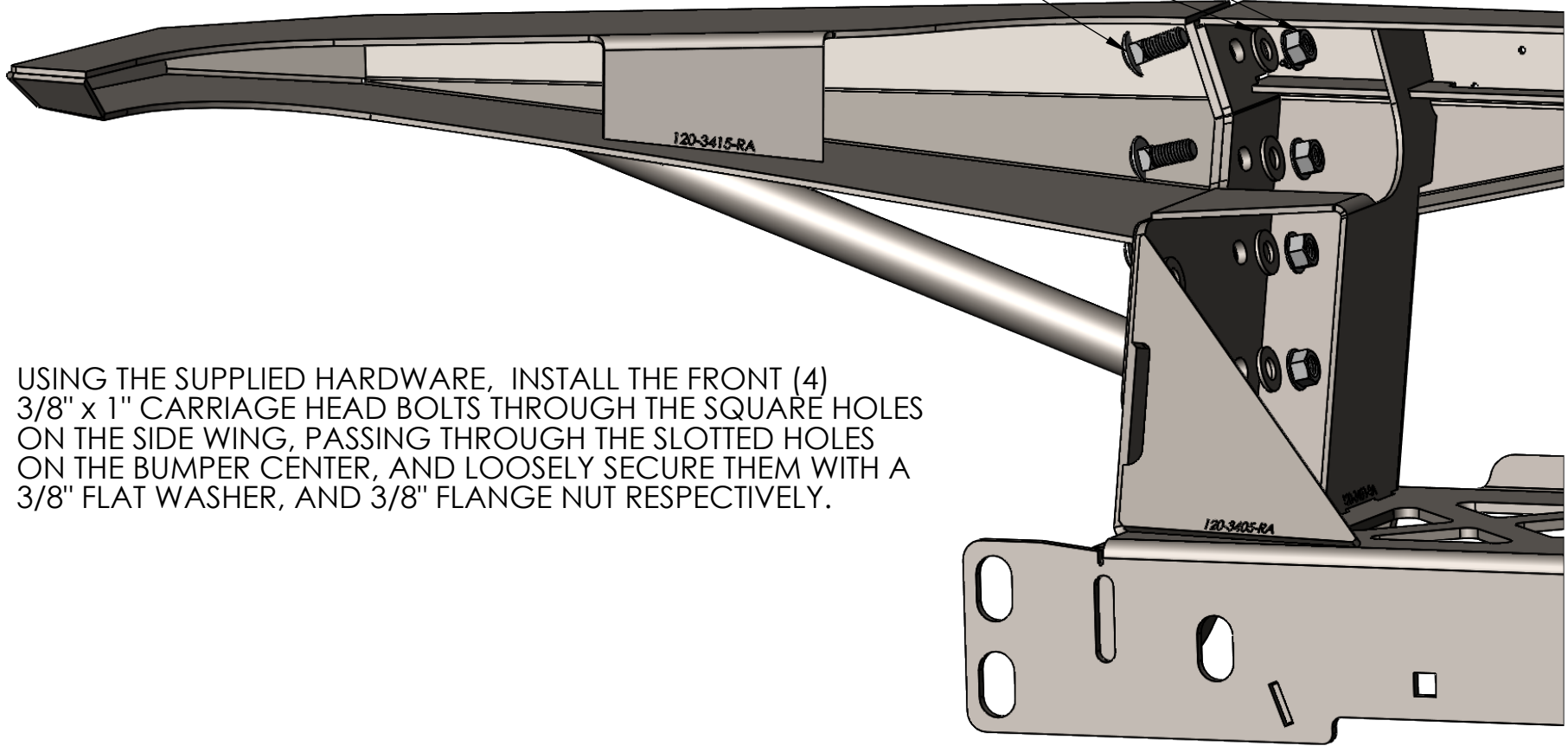

USING THE SUPPLIED HARDWARE, INSTALL THE FRONT (4) 3/8" x 1" CARRIAGE HEAD BOLTS THROUGH THE SQUARE HOLES ON THE SIDE WING, PASSING THROUGH THE SLOTTED HOLES ON THE BUMPER CENTER, AND LOOSELY SECURE THEM WITH A 3/8" FLAT WASHER, AND 3/8" FLANGE NUT RESPECTIVELY.

B

B

A

A



PROPRIETARY AND CONFIDENTIAL
 THE INFORMATION CONTAINED IN THIS DRAWING IS THE SOLE PROPERTY OF C4 FABRICATION, LLC. ANY REPRODUCTION IN PART OR AS A WHOLE WITHOUT THE WRITTEN PERMISSION OF C4 FABRICATION, LLC IS PROHIBITED.

MATERIAL

	NAME	DATE
DRAWN	EJK	11/1/23
CHECKED		
ENG APPR.		
MFG APPR.		
Q.A.		
COMMENTS:		

C4 FABRICATION

TITLE:
**2016-2023 TACOMA
 ROCK RUNNER FRONT**

SIZE A	DWG. NO.	REV A
------------------	----------	-----------------

DO NOT SCALE DRAWING

SHEET 3 OF 15

2

1

2

1

TUBE SIDE WINGS

LINE UP FRONT AND TOP FACES OF SIDE WING TO BE FLUSH WITH BUMPER CENTER SECTION

B

B

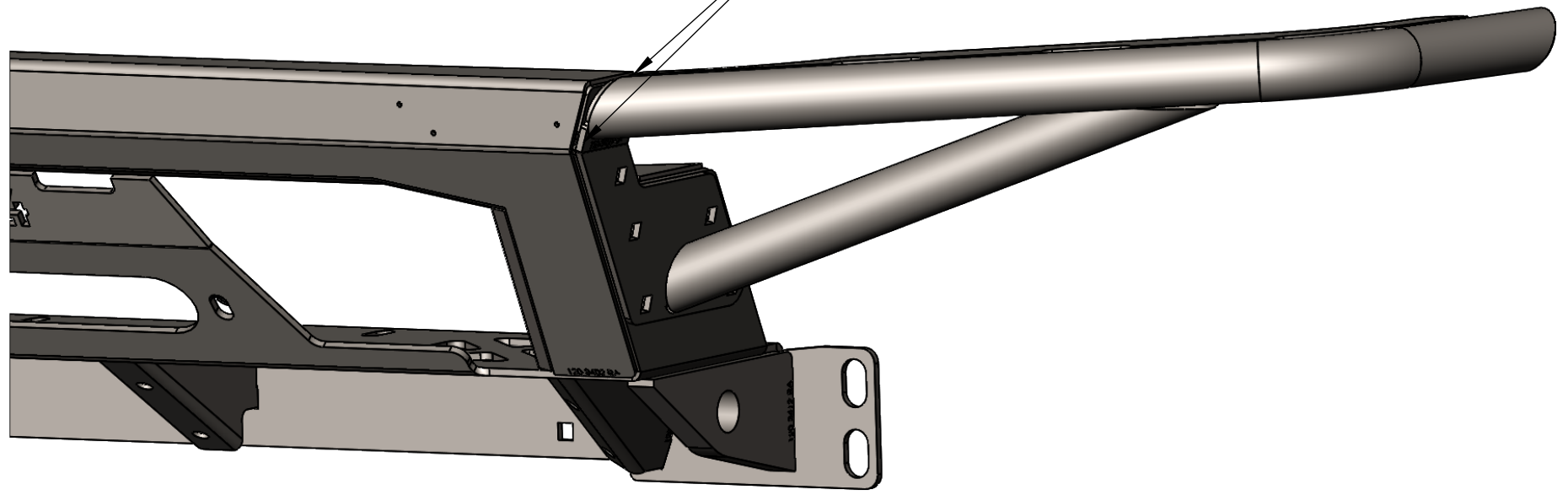

A

A



PROPRIETARY AND CONFIDENTIAL
 THE INFORMATION CONTAINED IN THIS DRAWING IS THE SOLE PROPERTY OF C4 FABRICATION, LLC. ANY REPRODUCTION IN PART OR AS A WHOLE WITHOUT THE WRITTEN PERMISSION OF C4 FABRICATION, LLC IS PROHIBITED.

MATERIAL

	NAME	DATE
DRAWN	EJK	11/1/23
CHECKED		
ENG APPR.		
MFG APPR.		
Q.A.		
COMMENTS:		

C4 FABRICATION

TITLE:
**2016-2023 TACOMA
 ROCK RUNNER FRONT**

SIZE A	DWG. NO.	REV A
------------------	----------	-----------------

2

1

2

1

TUBE SIDE WINGS

3/8"x1" BOLT (x1)

3/8"x1" CARRIAGE HEAD BOLT (x3)

3/8" FLAT WASHER (x4)

3/8" FLANGE NUT (x3)

USING THE SUPPLIED HARDWARE, INSTALL THE FRONT (3) 3/8" x 1" CARRIAGE HEAD BOLTS THROUGH THE SQUARE HOLES ON THE SIDE WING, PASSING THROUGH THE SLOTTED HOLES ON THE BUMPER CENTER, AND LOOSELY SECURE THEM WITH A 3/8" FLAT WASHER, AND 3/8" FLANGE NUT RESPECTIVELY. NEXT INSTALL THE 3/8" x 1" BOLT AND 3/8" FLAT WASHER FROM THE BUMPER SIDE INTO THE TOP TUBE OF THE SIDE WING.

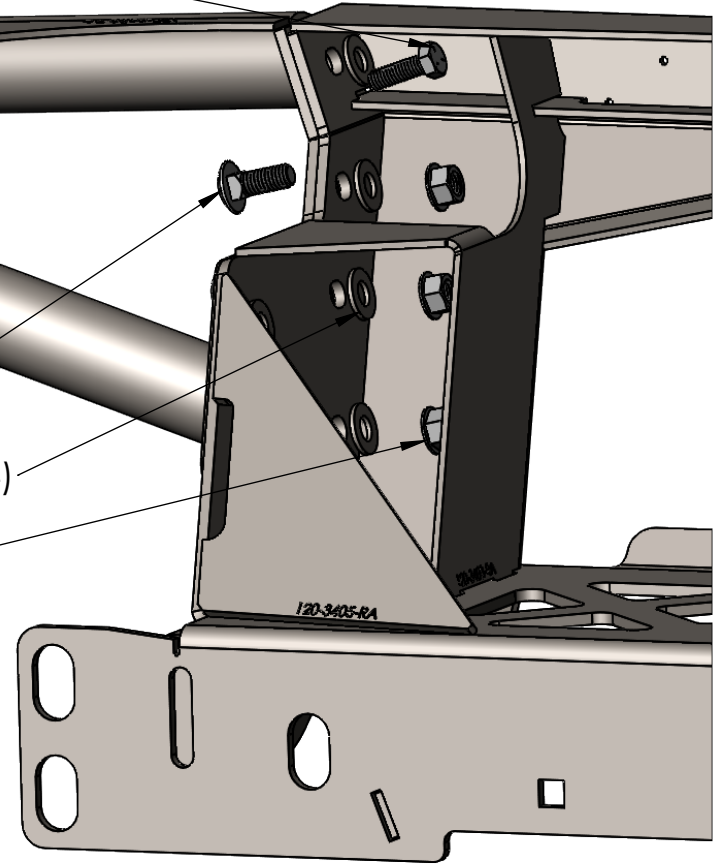

B

B

A

A



PROPRIETARY AND CONFIDENTIAL
THE INFORMATION CONTAINED IN THIS DRAWING IS THE SOLE PROPERTY OF C4 FABRICATION, LLC. ANY REPRODUCTION IN PART OR AS A WHOLE WITHOUT THE WRITTEN PERMISSION OF C4 FABRICATION, LLC IS PROHIBITED.

MATERIAL

	NAME	DATE
DRAWN	EJK	11/1/23
CHECKED		
ENG APPR.		
MFG APPR.		
Q.A.		
COMMENTS:		

C4 FABRICATION

TITLE:
**2016-2023 TACOMA
ROCK RUNNER FRONT**

SIZE A	DWG. NO.	REV A
------------------	----------	-----------------

2

1

2

1

B

B

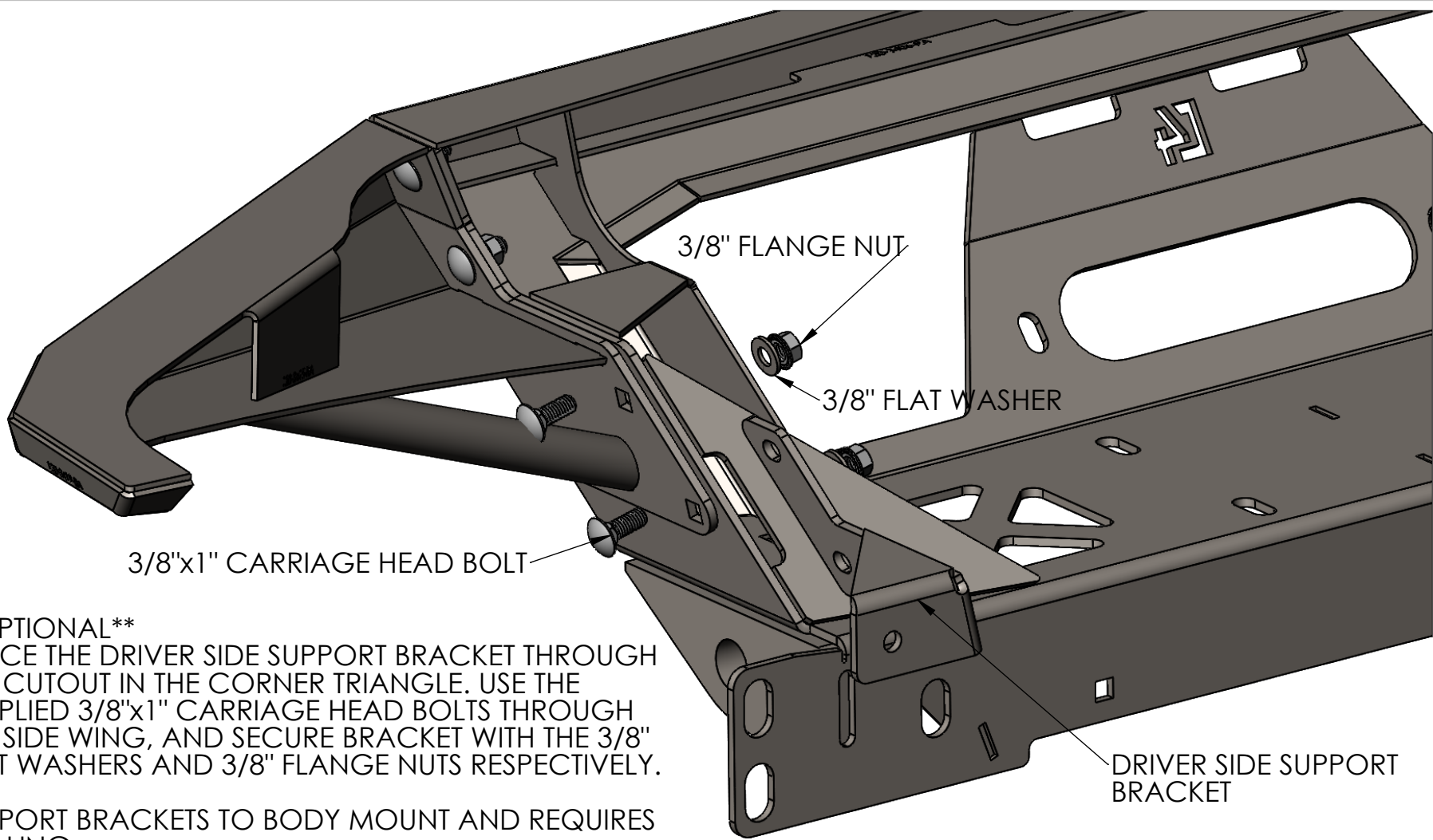

3/8"x1" CARRIAGE HEAD BOLT

3/8" FLANGE NUT

3/8" FLAT WASHER

DRIVER SIDE SUPPORT BRACKET

****OPTIONAL****

PLACE THE DRIVER SIDE SUPPORT BRACKET THROUGH THE CUTOUT IN THE CORNER TRIANGLE. USE THE SUPPLIED 3/8"x1" CARRIAGE HEAD BOLTS THROUGH THE SIDE WING, AND SECURE BRACKET WITH THE 3/8" FLAT WASHERS AND 3/8" FLANGE NUTS RESPECTIVELY.

SUPPORT BRACKETS TO BODY MOUNT AND REQUIRES DRILLING.

A

IF NOT USED, USE SUPPLIED HARDWARE TO FINISH MOUNTING SIDE WING.



PROPRIETARY AND CONFIDENTIAL
 THE INFORMATION CONTAINED IN THIS DRAWING IS THE SOLE PROPERTY OF C4 FABRICATION, LLC. ANY REPRODUCTION IN PART OR AS A WHOLE WITHOUT THE WRITTEN PERMISSION OF C4 FABRICATION, LLC IS PROHIBITED.

MATERIAL

	NAME	DATE
DRAWN	EJK	11/1/23
CHECKED		
ENG APPR.		
MFG APPR.		
Q.A.		
COMMENTS:		

C4 FABRICATION

TITLE:
**2016-2023 TACOMA
 ROCK RUNNER FRONT**

SIZE A	DWG. NO.	REV A
------------------	----------	-----------------

2

1

A

2

1

B

B

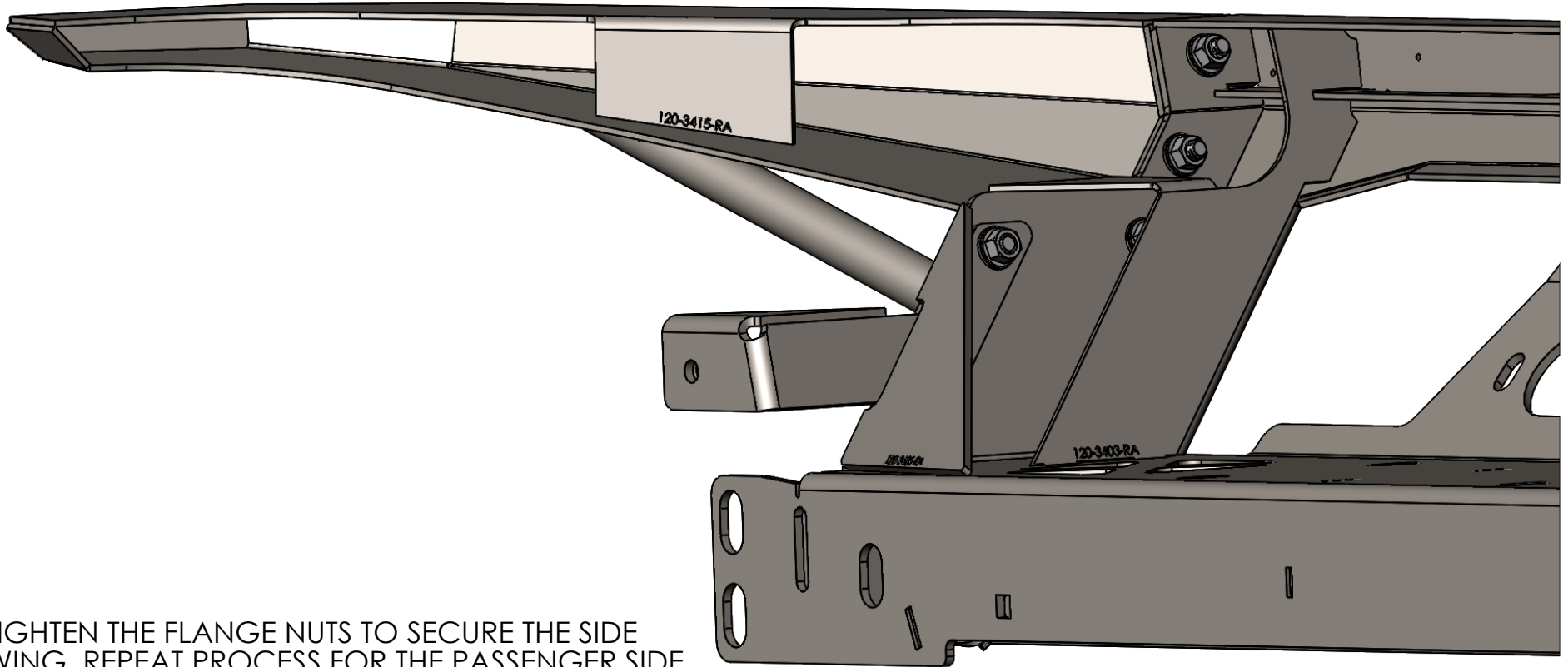

TIGHTEN THE FLANGE NUTS TO SECURE THE SIDE WING. REPEAT PROCESS FOR THE PASSENGER SIDE. TEST FIT THE BUMPER ON THE FRONT OF THE TACOMA TO ENSURE THE SUPPORT BRACKETS AND/OR SIDE WINGS DONT NEED ANY ADJUSTMENTS. ADJUST IF NEEDED, AND TORQUE FLANGE NUTS TO 55 FT-LBS.

A

A



PROPRIETARY AND CONFIDENTIAL
 THE INFORMATION CONTAINED IN THIS DRAWING IS THE SOLE PROPERTY OF C4 FABRICATION, LLC. ANY REPRODUCTION IN PART OR AS A WHOLE WITHOUT THE WRITTEN PERMISSION OF C4 FABRICATION, LLC IS PROHIBITED.

MATERIAL

	NAME	DATE
DRAWN	EJK	11/1/23
CHECKED		
ENG APPR.		
MFG APPR.		
Q.A.		
COMMENTS:		

C4 FABRICATION

TITLE:
**2016-2023 TACOMA
 ROCK RUNNER FRONT**

SIZE	DWG. NO.	REV
A		A

DO NOT SCALE DRAWING

SHEET 7 OF 15

2

1

2

1

M2.5x16MM BUTTON HEAD BOLT (x3)

ROCK RUNNER
LOGO PLATE

M2.5 FLAT WASHER

M2.5 LOCK WASHER

M2.5 NUT

USE THE SUPPLIED M2.5 BUTTON HEAD BOLTS TO SECURE THE ROCK RUNNER LOGO TO THE FRONT OF THE BUMPER IN THE (3) EXISTING HOLES. SECURE TO THE BUMPER USING THE SUPPLIED M2.5 FLAT WASHER, M2.5 LOCK WASHER, AND M2.5 NUT RESPECTIVELY.

FRONT VIEW

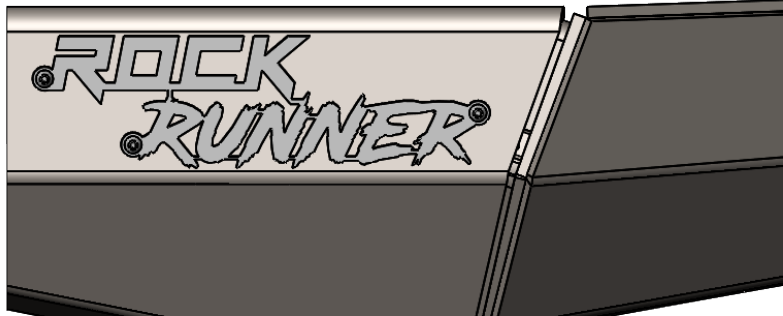

 PROPRIETARY AND CONFIDENTIAL THE INFORMATION CONTAINED IN THIS DRAWING IS THE SOLE PROPERTY OF C4 FABRICATION, LLC. ANY REPRODUCTION IN PART OR AS A WHOLE WITHOUT THE WRITTEN PERMISSION OF C4 FABRICATION, LLC IS PROHIBITED. MATERIAL	DRAWN	NAME	DATE	C4 FABRICATION TITLE: 2016-2023 TACOMA ROCK RUNNER FRONT SIZE A DWG. NO. REV A DO NOT SCALE DRAWING SHEET 8 OF 15
	CHECKED	EJK	11/1/23	
	ENG APPR.			
	MFG APPR.			
	Q.A.			
	COMMENTS:			

2

1

B

B

A

A

2

1

****OPTIONAL****

IF INSTALLING A WINCH, LINE UP WITH THE FOUR SLOTTED HOLES ON THE WINCH PLATE OF THE BUMPER AND USE HARDWARE SUPPLIED WITH WINCH (NOT INCLUDED). NOW WOULD ALSO BE THE TIME TO INSTALL FAIRLEAD TO THE BUMPER (NOT INCLUDED)

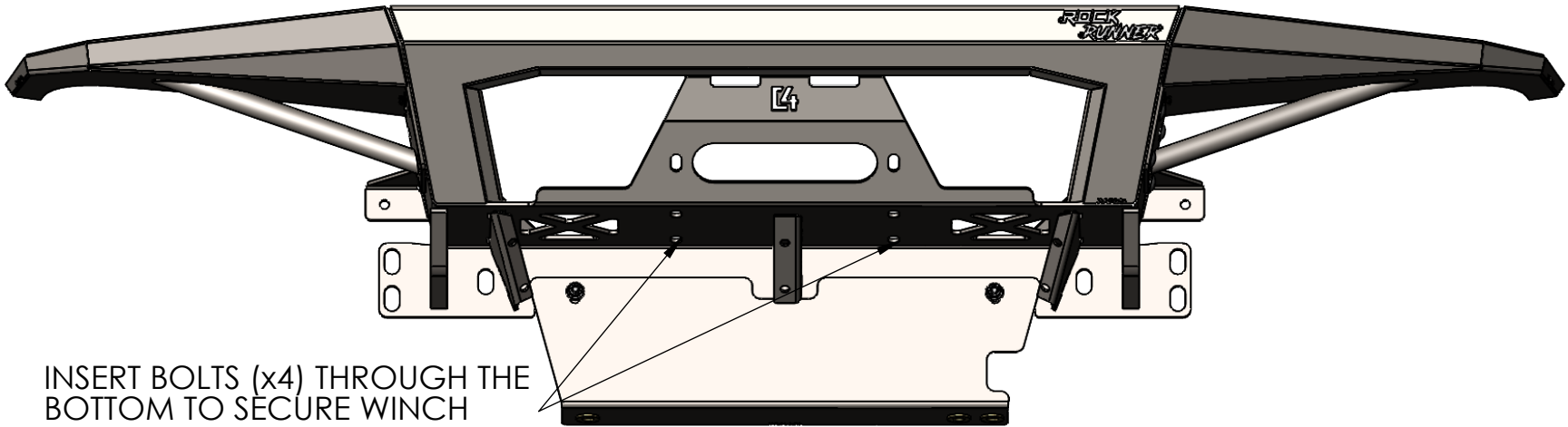

INSERT BOLTS (x4) THROUGH THE BOTTOM TO SECURE WINCH

B

B

A

A

 <p>PROPRIETARY AND CONFIDENTIAL THE INFORMATION CONTAINED IN THIS DRAWING IS THE SOLE PROPERTY OF C4 FABRICATION, LLC. ANY REPRODUCTION IN PART OR AS A WHOLE WITHOUT THE WRITTEN PERMISSION OF C4 FABRICATION, LLC IS PROHIBITED.</p> <p>MATERIAL</p>		NAME	DATE	<p>C4 FABRICATION</p> <p>TITLE: 2016-2023 TACOMA ROCK RUNNER FRONT</p>		
	DRAWN	EJK	11/1/23			
	CHECKED					
	ENG APPR.					
	MFG APPR.					
	Q.A.			SIZE	DWG. NO.	REV
	COMMENTS:			A		A
				DO NOT SCALE DRAWING		SHEET 9 OF 15

2

1

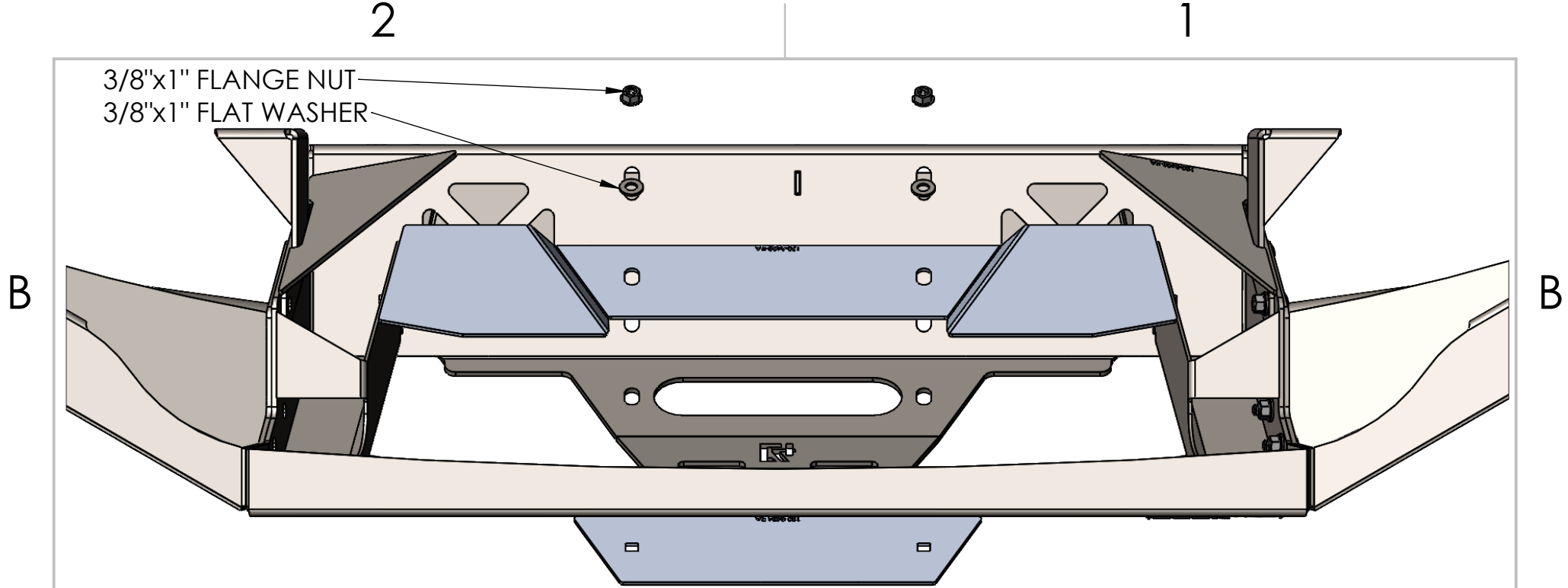

3/8"x1" CARRIAGE HEAD BOLT

****OPTIONAL****

IF NOT USING A WINCH, THE SUPPLIED ALUMINUM COVER PLATES CAN BE INSTALLED. USE THE SUPPLIED 3/8"x1" CARRIAGE HEAD BOLTS TO PASS THROUGH THE SMALLER ALUMINUM COVER. NEXT PASS THE BOLTS THROUGH THE SLOTS ON THE BUMPER, AND THE LARGER ALUMINUM COVER. SECURE USING THE SUPPLIED 3/8" FLAT WASHER AND 3/8" FLANGE NUTS RESPECTIVELY.

A

 <p>PROPRIETARY AND CONFIDENTIAL THE INFORMATION CONTAINED IN THIS DRAWING IS THE SOLE PROPERTY OF C4 FABRICATION, LLC. ANY REPRODUCTION IN PART OR AS A WHOLE WITHOUT THE WRITTEN PERMISSION OF C4 FABRICATION, LLC IS PROHIBITED.</p> <p>MATERIAL</p>		NAME	DATE	<p>C4 FABRICATION</p> <p>TITLE: 2016-2023 TACOMA ROCK RUNNER FRONT</p> <p>SIZE A DWG. NO. REV A</p> <p>DO NOT SCALE DRAWING SHEET 10 OF 15</p>
	DRAWN	EJK	11/1/23	
	CHECKED			
	ENG APPR.			
	MFG APPR.			
	Q.A.			
	COMMENTS:			

A

2

1

2

1

B

B

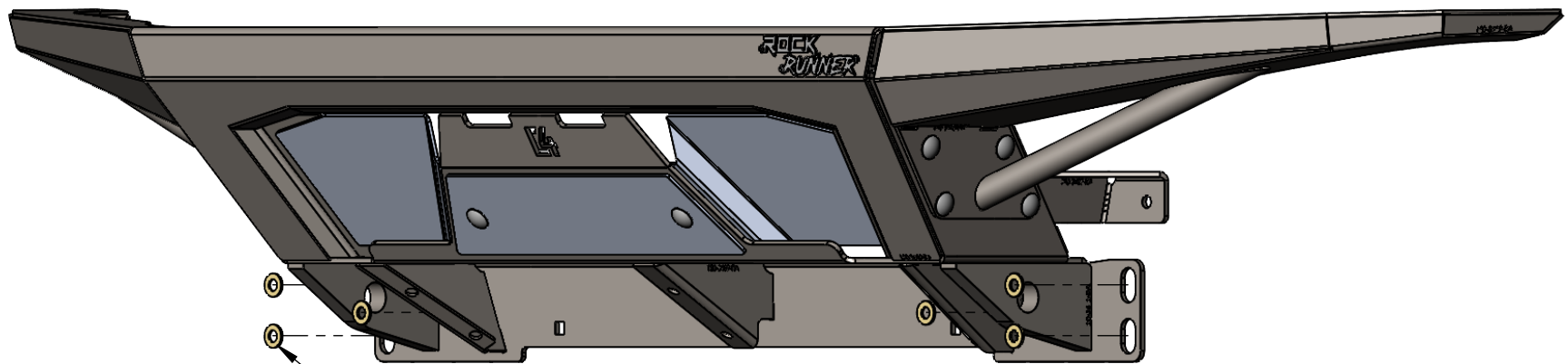

3/8" GRADE 8 FLAT WASHER (x6)

USE SUPPLIED 3/8" GRADE 8 FLAT WASHERS AND EXISTING M8 FLANGE NUTS THAT WAS HOLDING THE CRASH BAR ON TO SECURE THE BUMPER TO THE PICKUP. TORQUE M8 BOLTS TO 55 FT-LBS ON THE FRAME STUDS.

A

A



PROPRIETARY AND CONFIDENTIAL
 THE INFORMATION CONTAINED IN THIS DRAWING IS THE SOLE PROPERTY OF C4 FABRICATION, LLC. ANY REPRODUCTION IN PART OR AS A WHOLE WITHOUT THE WRITTEN PERMISSION OF C4 FABRICATION, LLC IS PROHIBITED.

MATERIAL

	NAME	DATE
DRAWN	EJK	11/1/23
CHECKED		
ENG APPR.		
MFG APPR.		
Q.A.		
COMMENTS:		

C4 FABRICATION

TITLE:
**2016-2023 TACOMA
 ROCK RUNNER FRONT**

SIZE A	DWG. NO.	REV A
------------------	----------	-----------------

2

1

2

1

B

B

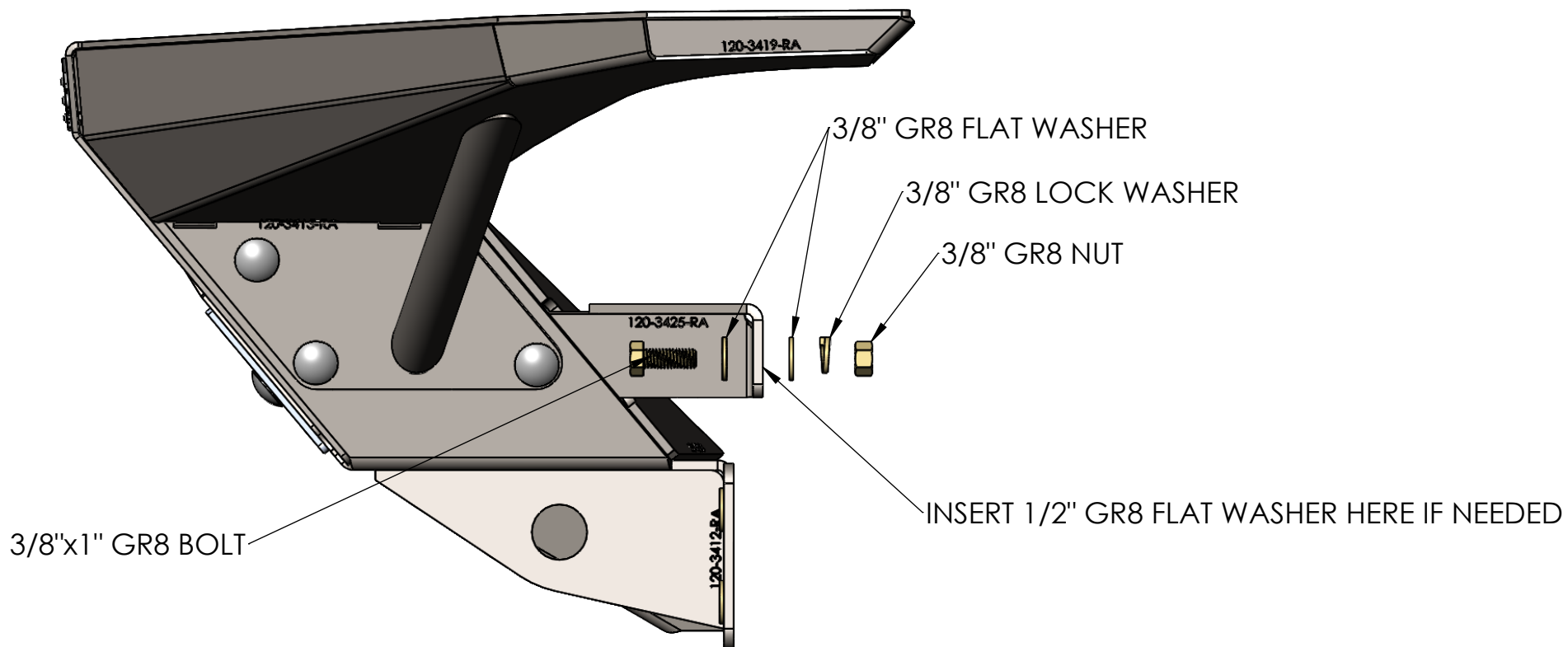

3/8"x1" GR8 BOLT

3/8" GR8 FLAT WASHER

3/8" GR8 LOCK WASHER

3/8" GR8 NUT

INSERT 1/2" GR8 FLAT WASHER HERE IF NEEDED

****OPTIONAL****
 IF USING SUPPORT BRACKETS, DRILL A 7/16" HOLE IN BODY MOUNT, SECURE BRACKET TO BODY MOUNT USING SUPPLIED 3/8" x 1" GRADE 8 BOLT, 3/8" FLAT WASHERS, 3/8" GR8 LOCK WASHER, AND 3/8" GR8 NUT RESPECTIVELY. IF THERE SUPPORT BRACKET IS NOT FLUSH WITH BODY MOUNT, USE SUPPLIED 1/2" GR8 FLAT WASHER TO FILL GAP. TORQUE TO 55 FT-LBS. REPEAT PROCESS ON PASSENGER SIDE.

A

A



PROPRIETARY AND CONFIDENTIAL
 THE INFORMATION CONTAINED IN THIS DRAWING IS THE SOLE PROPERTY OF C4 FABRICATION, LLC. ANY REPRODUCTION IN PART OR AS A WHOLE WITHOUT THE WRITTEN PERMISSION OF C4 FABRICATION, LLC IS PROHIBITED.

MATERIAL

	NAME	DATE
DRAWN	EJK	11/1/23
CHECKED		
ENG APPR.		
MFG APPR.		
Q.A.		
COMMENTS:		

C4 FABRICATION

TITLE:
**2016-2023 TACOMA
 ROCK RUNNER FRONT**

SIZE A	DWG. NO.	REV A
------------------	----------	-----------------

2

1

2

1

B

B

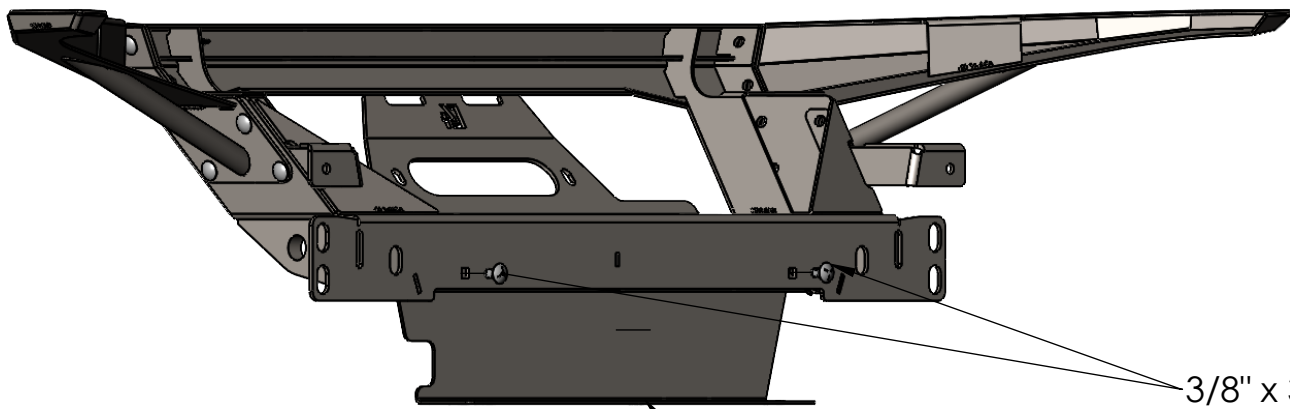
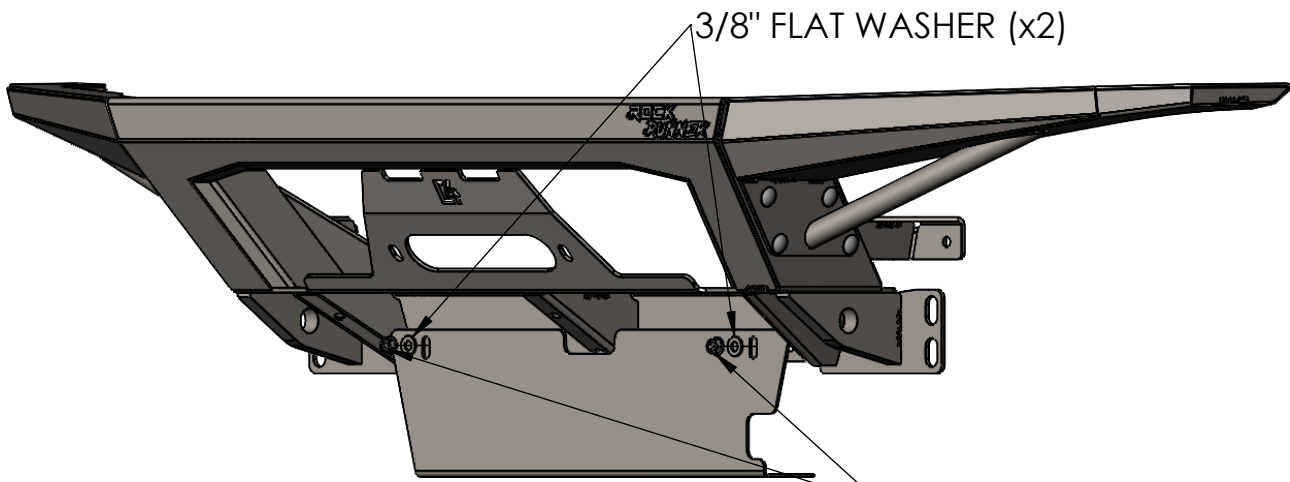

****OPTIONAL****
 IF NOT DELETING THE CROSSMEMBER, USE THE SUPPLIED 3/8" x 3/4" CARRIAGE HEAD BOLTS, 3/8" FLAT WASHERS, AND 3/8" FLANGE NUTS RESPECTIVELY TO LOOSELY SECURE THE CROSSMEMBER FILL PLATE TO THE BUMPER.



PROPRIETARY AND CONFIDENTIAL
 THE INFORMATION CONTAINED IN THIS DRAWING IS THE SOLE PROPERTY OF C4 FABRICATION, LLC. ANY REPRODUCTION IN PART OR AS A WHOLE WITHOUT THE WRITTEN PERMISSION OF C4 FABRICATION, LLC IS PROHIBITED.

MATERIAL

	NAME	DATE
DRAWN	EJK	11/1/23
CHECKED		
ENG APPR.		
MFG APPR.		
Q.A.		
COMMENTS:		

C4 FABRICATION

TITLE:
**2016-2023 TACOMA
 ROCK RUNNER FRONT**

SIZE A	DWG. NO.	REV A
------------------	----------	-----------------

2

1

A

A

2

1

****OPTIONAL IF NOT DELETING CROSSMEMBER****

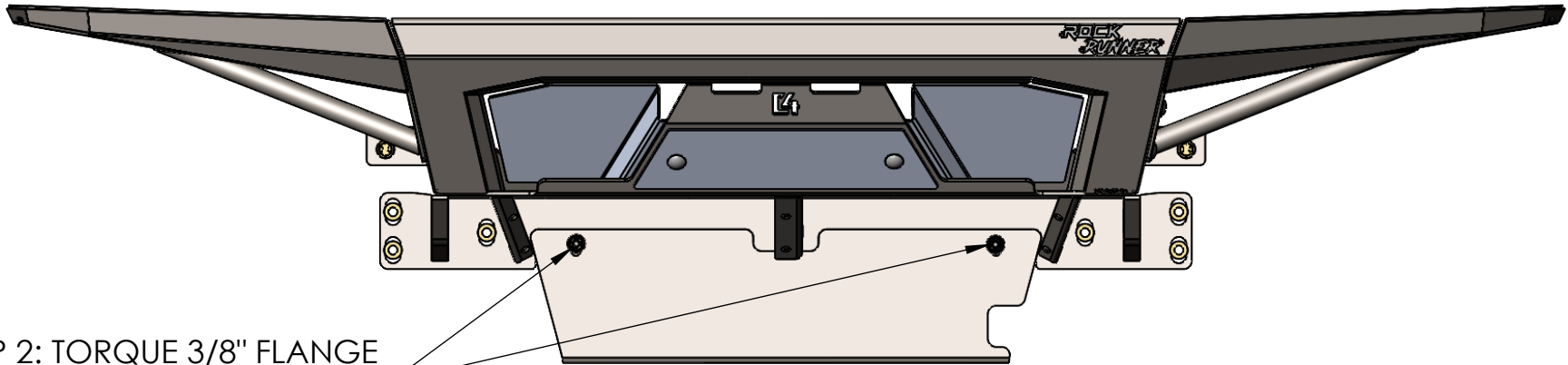

STEP 2: TORQUE 3/8" FLANGE NUTS TO 45 FT-LBS.

STEP 1: USING EXISTING M10 BOLTS FROM CROSSMEMBER TO SECURE THE CROSSMEMBER FILL PLATE TO THE CROSSMEMBER. TORQUE TO 45 FT-LBS.

B

B

A

A



PROPRIETARY AND CONFIDENTIAL
 THE INFORMATION CONTAINED IN THIS DRAWING IS THE SOLE PROPERTY OF C4 FABRICATION, LLC. ANY REPRODUCTION IN PART OR AS A WHOLE WITHOUT THE WRITTEN PERMISSION OF C4 FABRICATION, LLC IS PROHIBITED.

MATERIAL

	NAME	DATE
DRAWN	EJK	11/1/23
CHECKED		
ENG APPR.		
MFG APPR.		
Q.A.		
COMMENTS:		

C4 FABRICATION

TITLE:

**2016-2023 TACOMA
ROCK RUNNER FRONT**

SIZE
A

DWG. NO.

REV
A

DO NOT SCALE DRAWING

SHEET 14 OF 15

2

1

2

1

B

B

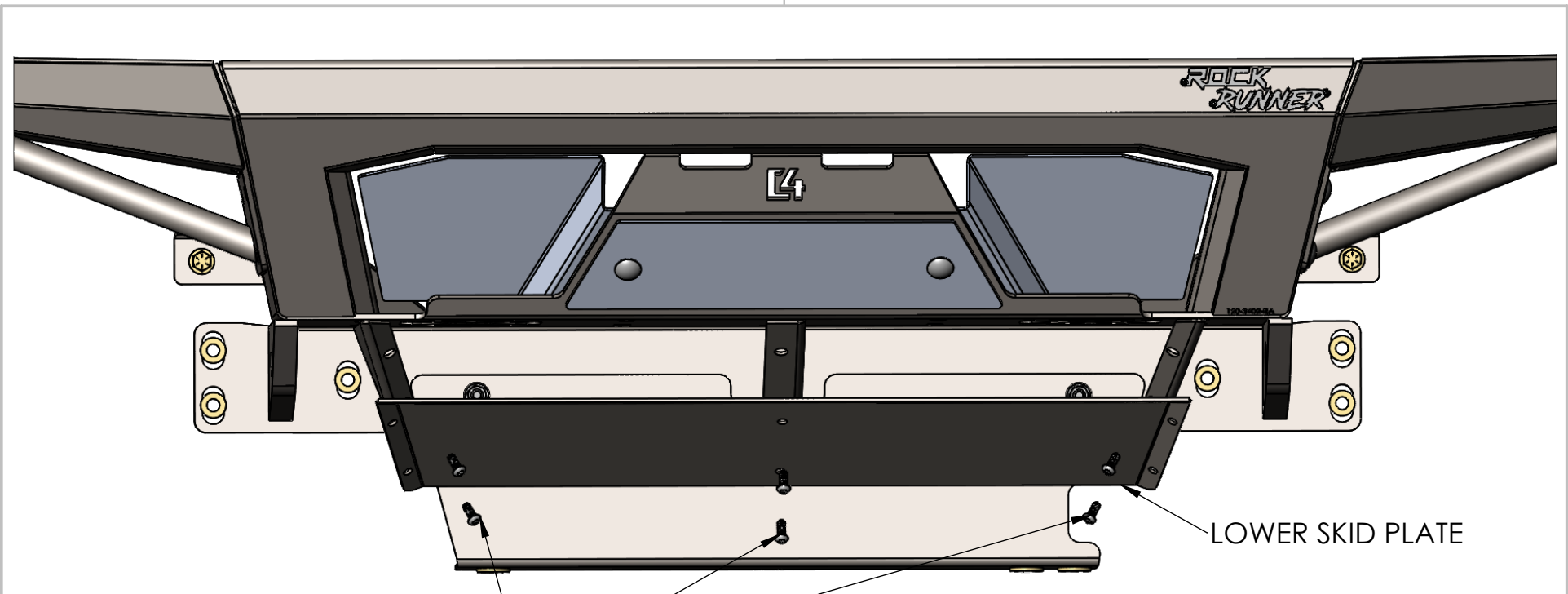

LOWER SKID PLATE

1/4"-20 x 5/8" BUTTON HEAD BOLT (x6)

USING THE SUPPLIED 1/4"-20 x 5/8" BUTTON HEAD BOLTS, SECURE THE LOWER SKID PLATE TO THE BUMPER. THERE WILL BE EXISTING NUTS WELDED TO THE BUMPER TO FASTEN BOLTS TO.

A

A

 <p>PROPRIETARY AND CONFIDENTIAL THE INFORMATION CONTAINED IN THIS DRAWING IS THE SOLE PROPERTY OF C4 FABRICATION, LLC. ANY REPRODUCTION IN PART OR AS A WHOLE WITHOUT THE WRITTEN PERMISSION OF C4 FABRICATION, LLC IS PROHIBITED.</p> <p>MATERIAL</p>	DRAWN	NAME	DATE	<p>C4 FABRICATION</p> <p>TITLE: 2016-2023 TACOMA ROCK RUNNER FRONT</p> <p>SIZE A DWG. NO. REV A</p> <p>DO NOT SCALE DRAWING SHEET 15 OF 15</p>
	CHECKED	EJK	11/1/23	
	ENG APPR.			
	MFG APPR.			
	Q.A.			
	COMMENTS:			

2

1