

12



SECTION TWELVE

[12-1 COVER STAY - MILD DUTY](#)

[12-2 COVER STAY - HEAVY DUTY](#)

[12-3 COVER STAY - EXTRA HEAVY DUTY](#)

[12-4 LIFTING EYE BOLTS](#)

MILD DUTY COVER STAY

FEATURES:

- Available to suit left or right hand applications
- For light to medium duty applications

DIMENSIONS:

Length = 292mm

MATERIAL & FINISH:

Mild steel, zinc plated
Stainless steel

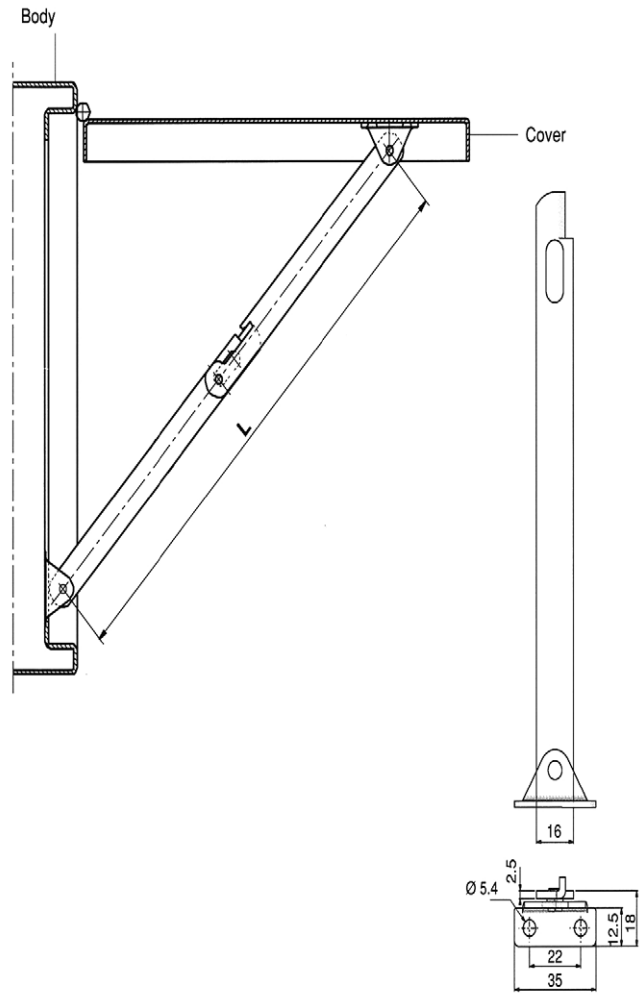

MATERIAL	FINISH	HANDEDNESS	PART NUMBER
Mild steel	Zinc plated	Left hand	M079-6-3-292-001
Mild steel	Zinc plated	Right hand	M079-6-3-292-002
Stainless steel	-	Left hand	M079-4-0-292-001
Stainless steel	-	Right hand	M079-4-0-292-002

HEAVY DUTY COVER STAY

FEATURES:

- Automatic lock to keep door open
- For heavy duty applications

DIMENSIONS:

Length = 230mm

MATERIAL & FINISH:

Mild steel, zinc plated
Stainless steel

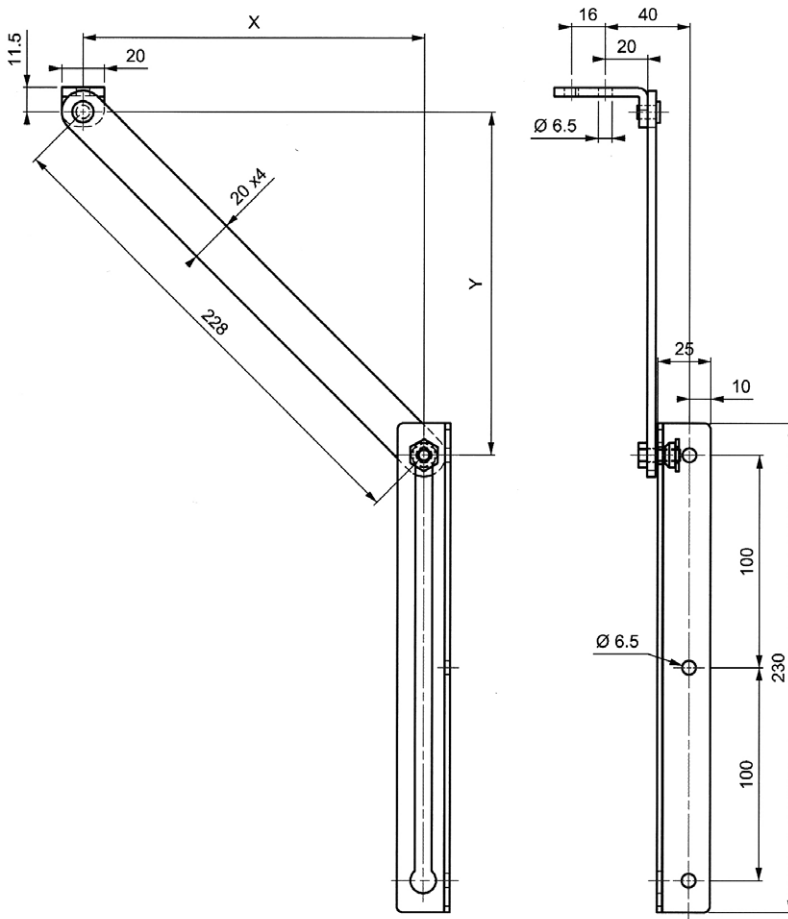

OPENING ANGLE	DIMENSION		MINIMAL DOOR WIDTH
	X	Y	
90°	140	180	403
105°	120	166	389
120°	110	150	373
135°	100	146	369

MATERIAL	FINISH	PART NUMBER
Mild Steel	Zinc plated	M179-44-002
Stainless steel	-	M179-44-001



EXTRA HEAVY DUTY COVER STAY

FEATURES:

- Suitable for left or right hand applications
- Automatic lock to keep door open
- For extra heavy duty usage

DIMENSIONS:

Length = 215mm

MATERIAL & FINISH:

Mild steel, nickel plated

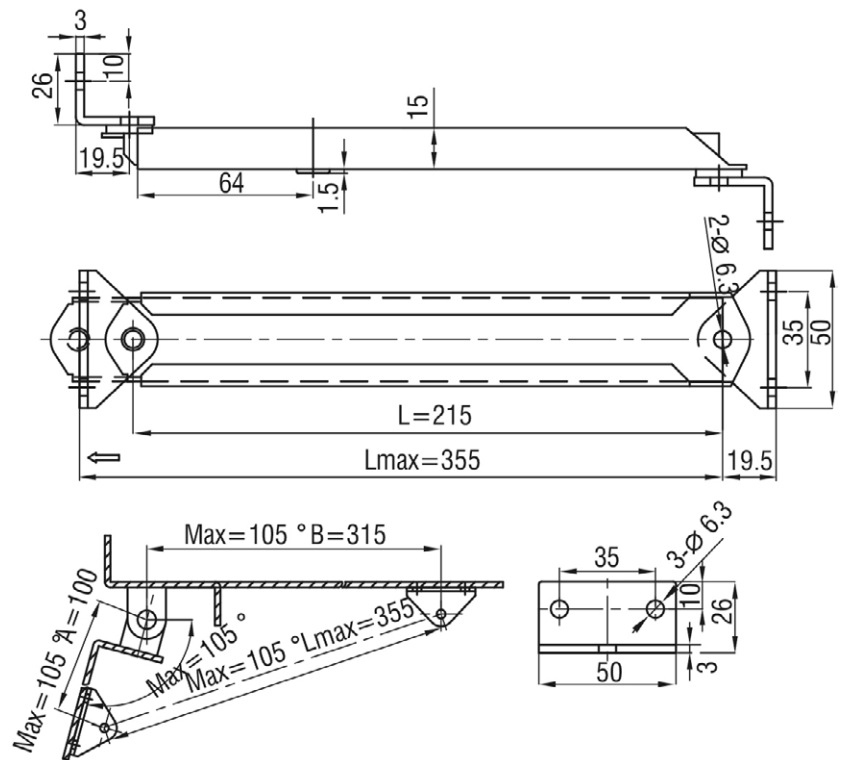

MATERIAL	FINISH	PART NUMBER
Mild steel	Nickel plated	SEL-230-9306

LIFTING EYEBOLTS

FEATURES:

- Zinc chromate plated
- Available in M12 or M16 thread
- SWL: M12 = 0.22T
M16 = 0.45T

DIMENSIONS:

See table

MATERIAL:

Cast iron

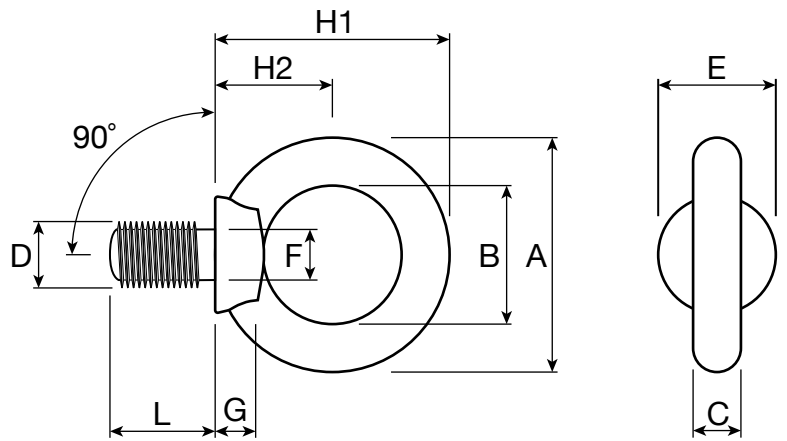

THREAD	DIMENSIONS											LOAD (KG)	
	A	B	C	D	E	F	G	H1	H2	L	VERTICAL	45° HUNG	
M12	50	30	10	12	25	9.3	9	51	26	22	220	220	
M16	60	35	12.5	16	30	13	11	60	30	27	450	450	

THREAD	FINISH	PART NUMBER
M12	Zinc chromate plated	AL-EYEBOLT-M12
M16	Zinc chromate plated	AL-EYEBOLT-M16
M12	Galvanized	AL-EYEBOLT-M12-GALV