

10



SECTION TEN

- [10-1 PINCHWELD SIDE MOUNT](#)
- [10-2 PINCHWELD TOP MOUNT](#)
- [10-4 EDGE PROTECTION](#)
- [10-5 SPECIAL PROFILE](#)
- [10-6 CLOSED CELL PVC NITRILE FOAM](#)
- [10-7 SELF ADHESIVE TAPE](#)
- [10-8 REAR DOOR SEAL](#)

SIDE MOUNT PROFILES

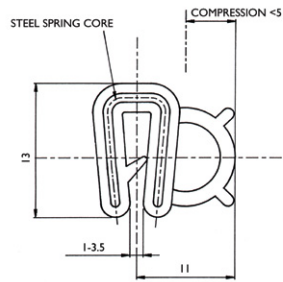
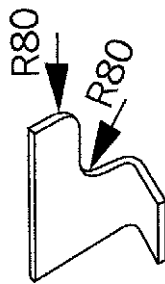

PART NUMBER

1011-106

Material: EPDM

Grip Range: 2.0mm

Packaging: 50m roll

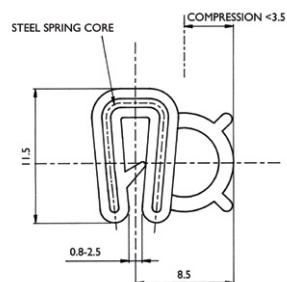
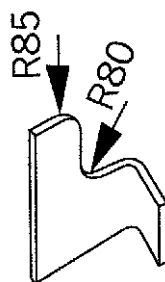

PART NUMBER

1011-109

Material: EPDM

Grip Range: 1.0 - 2.0mm

Packaging: 50m roll

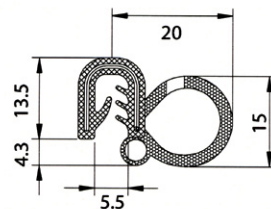
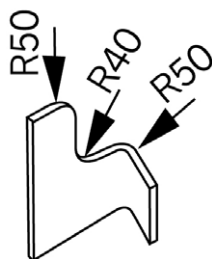

PART NUMBER

1011-A3297

Material: EPDM

Grip Range: 2.0mm

Packaging: 50m roll

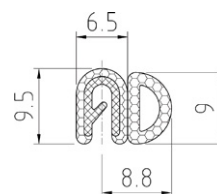
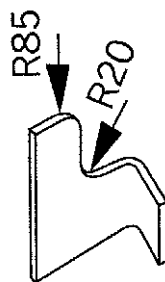

PART NUMBER

1011-10212

Material: EPDM

Grip Range: 1.0 - 2.0mm

Packaging: 100m roll

TOP MOUNT PROFILES

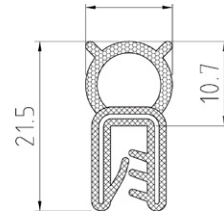
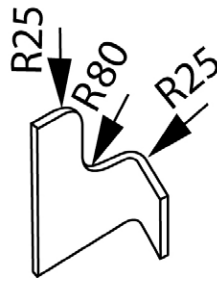

PART NUMBER

1011-105

1011-105-C
*for checkerplate

PART #	Material	Grip Range	Packaging
1011-105	EPDM	1.0 - 2.5mm	50m roll
1011-105-C	EPDM	1.0 - 3.0mm	50m roll

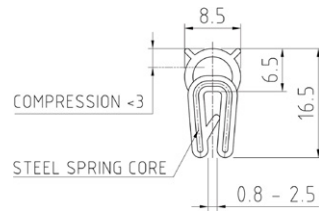
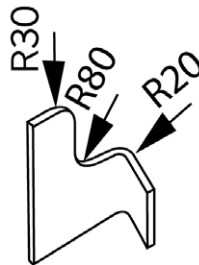

PART NUMBER

1011-110

Material: EPDM Grip Range: 1.0 - 2.0mm Packaging: 50m roll

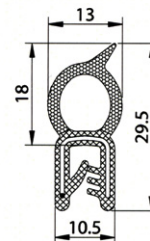
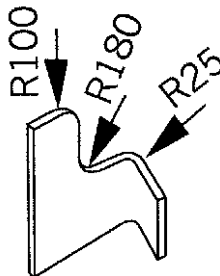

PART NUMBER

1011-A2516-4

Material: EPDM Grip Range: 2.5 - 4.0mm Packaging: 50m roll

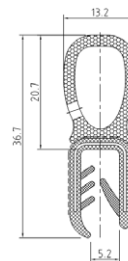

PART NUMBER

1011-A1030-E2583

Material: SPONGE RUBBER Grip Range: 4.0 - 6.0mm Packaging: 50m roll

TOP MOUNT PROFILES

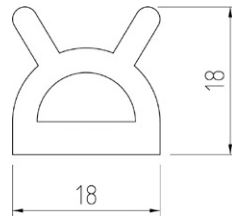

PART NUMBER

9187STS

Material: SELECTLOK PLUS Adhesive tape: 3M (ST) Packaging: 50m roll

EDGE PROTECTION

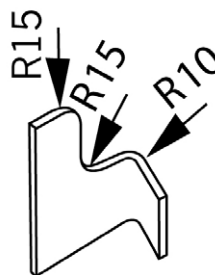
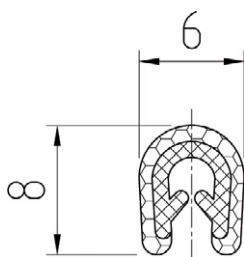

PART NUMBER

1011-10801

Material: PVC

Grip Range: 0.8 - 1.5mm

Packaging: 100m roll

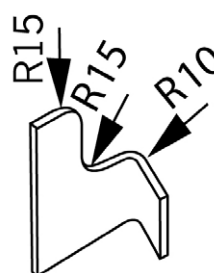
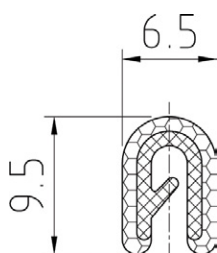

PART NUMBER

1011-10802

Material: PVC

Grip Range: 1.0 - 2.0mm

Packaging: 100m roll

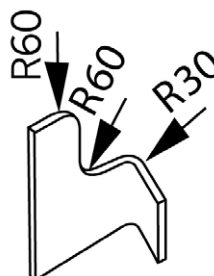
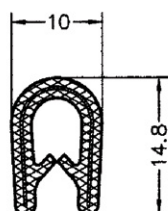

PART NUMBER

1011-10803

Material: PVC

Grip Range: 1.0 - 4.0mm

Packaging: 100m roll

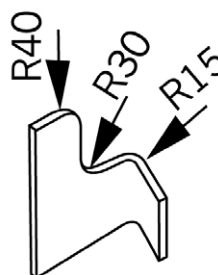
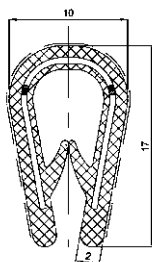

PART NUMBER

1011-A1018

Material: PVC

Grip Range: 2.0 - 4.0mm

Packaging: 50m roll

SPECIAL PROFILE



PART NUMBER

RSB256

Material: SPONGE RUBBER

Packaging: 50m roll

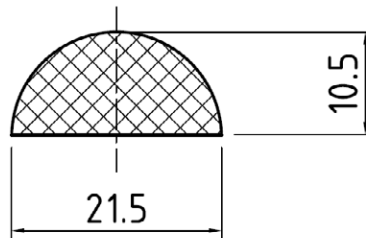

PART NUMBER

TZ-YN-004

Material: EPDM

Packaging: 50m roll

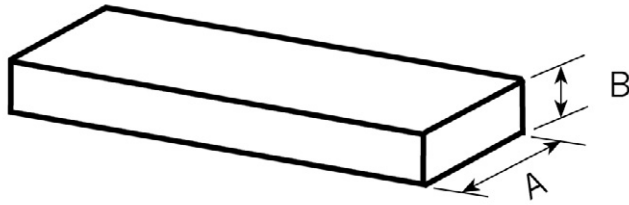

CLOSED CELL PVC NITRILE FOAM

TECHNICAL PROPERTIES	VALUE
Backing Material	Closed Cell PVC/Nitrile Foam
Adhesive Type	Acrylic
Adhesive Power	6 N/25mm
Foam Density	91 kgs/m ³
Elongation	100%
Tensile Strength	73.5 N/25mm
Water Tightness	100% at < 10% compression
Water Absorption ASTM D1056-73	6% (by weight)
Thermal Conductivity	0.27 btu
Temperature Resistance	- 10°C to + 80°C
Flammability ASTM D1692-74	Flame retardant and self extinguishing
Ozone Resistance	Good
UV Resistance	Good
Chemical/Solvent Resistance	Good
Petrol/Oil Resistance	Good
Tear Resistance	Good
Tape Thickness	3mm, 6mm, 9mm and 12mm
Tape Widths	6mm to 1220mm
Colour Available	Black

FEATURES:

- Foam compresses easily, is highly conformable and recovers quickly
- Filmic interliner prevents stretch during application
- Robust foam is tear and abrasion resistant
- Electrical non-conductive – can be used as an electrolysis barrier
- Good resistant to high temperature and weathering
- Good thermal insulation properties
- Available in die-cut pads and gaskets
- Supplied in 9m rolls

MATERIAL:

- Sealing electrical enclosures and switch cabinets
- Sealing industrial access doors and hatches
- Sealing hatches on boats
- Sealing externally mounted air conditioning equipment
- Pipe- wrap insulation of hot and cold pipes

"A" (mm)	"B" (mm)	MATERIAL	PART NUMBER
10	3	Sponge Nitrile	NITFT10X3
10	6	Sponge Nitrile	NITFT10X6
12	3	Sponge Nitrile	NITFT12X3
12	6	Sponge Nitrile	NITFT12X6
12	9	Sponge Nitrile	NITFT12X9
21	3	Sponge Nitrile	NITFT21X3
21	6	Sponge Nitrile	NITFT21X6
21	9	Sponge Nitrile	NITFT21X9
25	3	Sponge Nitrile	NITFT25X3
25	6	Sponge Nitrile	NITFT25X6
25	9	Sponge Nitrile	NITFT25X9



SELF ADHESIVE TAPE

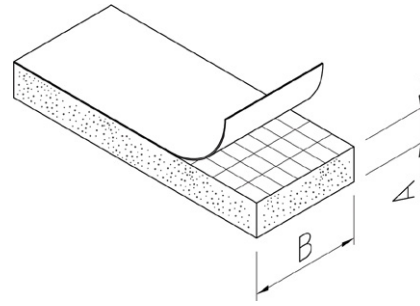

FEATURES:

- Scrim netting for better resistance to overstretching
- High quality adhesive
- Supplied in 10m rolls
- Other sizes available
- Closed cell construction

MATERIAL:

EPDM

TECHNICAL PROPERTIES	TEST METHOD	VALUE
Cellular Structure	-	Closed
Colour	-	Black
Density (kg/m ³)	ISO 845-88	130
Water Absorption (%)	ASTM D 1056	<8
Temperature Range Constant (°C)	ASTM D 3575	-40 / +80
Temperature Range Intermittent (°C)	-	-
Linear Shrinkage (%)	After 22H 70 °C	Max -5
Ultimate Elongation	ASTM D 412	>150
Tensile Strength (kpa)	ASTM D 412	400
Tear Resistance (kN/m)	ASTM D 624	0.5
Air + UV Resistance	Exellent	
Ozone Resistance	168 h/200pphm	
Compression Strength (kpa)	ASTM 1056-85	%25' de => 35
Compression Set (%)	ASTM D 395 (%50-22H)	5
Shore Hardness (Shore C)	ASTM D 2240	35 ±5
Fire Resistance	-	-
Peroxide Cure	-	-
Specification	-	-

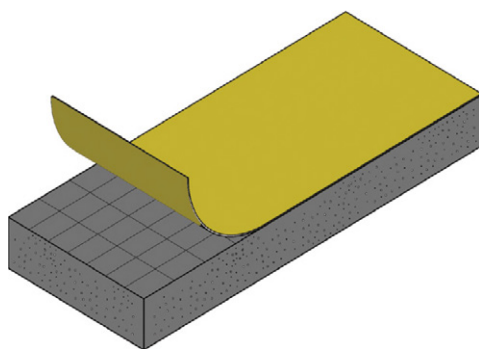

"A" (mm)	"B" (mm)	MATERIAL	PART NUMBER
3	20	EPDM	M1200-3-20
5	10	EPDM	M1200-5-10
5	25	EPDM	M1200-5-25
5	20	EPDM	M1200-5-20
5	30	EPDM	M1200-5-30
3	12	EPDM	EPDMFT12X3
3	24	EPDM	EPDMFT24X3
4.5	9	EPDM	EPDMFT9X4.5
4.5	18	EPDM	EPDMFT18X4.5
6	24	EPDM	EPDMFT24X6
9	24	EPDM	EPDMFT24X9
9	48	EPDM	EPDMFT48X9
12	18	EPDM	EPDMFT18X12

REAR DOOR SEAL

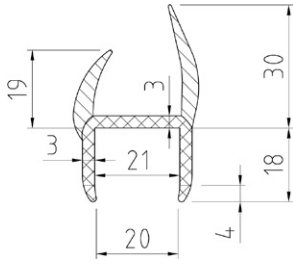

PART NUMBER

P-200-21

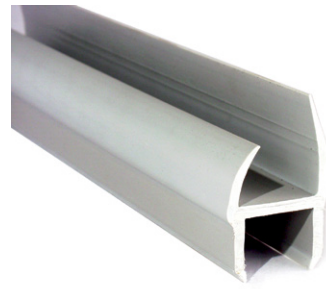

Material: PVC

Colour: Grey

Packaging: 5m lengths

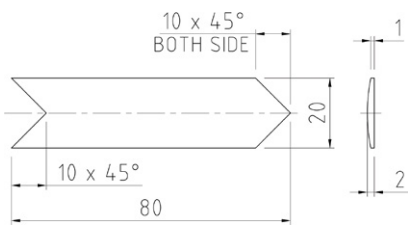

PART NUMBER

P2627

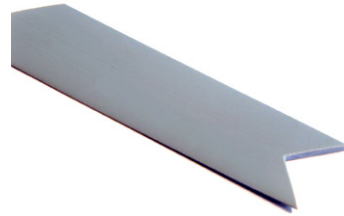

Material: PVC

Colour: Grey

Packaging: 100 pieces

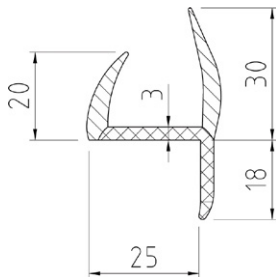

PART NUMBER

183020



Material: PVC

Colour: Grey

Packaging: 5m lengths

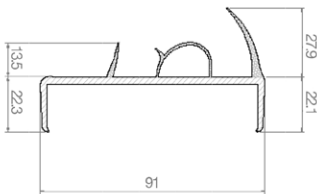

PART NUMBER

P-6081-B



Material: PVC

Colour: Grey

Packaging: 5m lengths