

SGR1500 Stump Grinder Manual

Instructions for Operation, Maintenance Compact Stump and Root Grinder

Your stump grinder is intended for outdoor-use only and can be used to remove many trees stumps and exposed root systems close to ground level. By moving the blade in sweeping movements laterally over the top and front of the stump, you can gradually grind it away. Make sure you completely read and understand this manual before using the grinder for the first time.

! WARNING !

READ and UNDERSTAND THIS MANUAL COMPLETELY BEFORE USING THE GRINDER! Failure to properly operate, and maintain this grinder could result in serious injury or death to the operator or bystanders.

All machines have hazards associated with their operation. This stump grinder has certain special hazards, which you must be aware of. As an operator or owner you have a duty to be aware of these hazards and know.

Preventive measures to take to avoid them. When reading this manual pay particular attention to avoiding these hazards.

● In particular, be aware of the following:

- Know location of buried electrical and other utility lines.
- Do not allow children or untrained adults to operate.
- Wear eye protection and other personal protection against flying rocks and debris.
- Check that cutter wheel teeth are secured, sharp and not missing.
- Do not operate if operator presence bar fails to stop engine upon release.
- Make sure no children or bystanders are within 75 feet of stump grinding operation.
- Protect cars, windows and other objects within 75 feet from flying debris.
- Be prepared for machine "kickback" when initially contacting the stump.
- Be aware of potential for carbon monoxide (CO) poisoning.
- Prevent fires/explosions from fueling.
- Do not attempt to perform adjustments, clean unit while engine is running.
- Avoid burns from engine or hot exhaust.
- Avoid using in wet or icy conditions where falls may occur.

Details about these hazards are found throughout the manual and are summarized at the end of the manual under "Important Safety Information"

! STOP !

ADD ENGINE OIL: Your stump grinder comes fully assembled and requires only that you add engine oil to crankcase and fuel to tank.

INSPECT COMPONENTS: Closely inspect to make sure no components are missing or damaged. See the "Receiving Your Unit" section for instructions on whom to contact to report missing or damaged parts.

SGR1500 Intended use statement

You must read below before operating this machine

This machine has been developed and designed for the purpose of grinding stumps **ONLY**, the stumps should have already been cut down to a Max Log Length (mm) 515 and a Max Log Length Below Ground (mm) 225, it is not suitable to grind any other type of material with this machine.

Please make sure all wood that is grinded with this machine is natural and organic i.e there is no screws, nails or any other debris embedded in the stump





Crytec Limited Declaration of Conformity



1. Product Model / Type:

- a. Product: Petrol Stump Grinder
- b. Model: SGR1500

2. Manufacturer:

- a. Name: Crytec Limited
- b. Address: Unit 1C Upper Mantle Close, Chesterfield S45 9ED, UK

3. This declaration is issued under the sole responsibility of the product manufacturer.

4. The object of the declaration described above is in conformity with the relevant UK Statutory Instruments:

2008 No 1597 The supply of Machinery (Safety) Regulations 2008 (and their amendments) and the Essential Health and Safety and the Essential Health and Safety Requirements

5. We hereby declare that the product described above, to which this declaration of conformity refers to, we have referenced the below designated standards used in relation to which conformity is declared:

Reference & Date	Title
EN ISO 12100 : 2010	Safety of Machinery
BS EN ISO 14120:2015	Safety of Machinery

EN13683:2003+A2:2011+AC:2015 and EN ISO 14982:2009

6. Additional Information:

The technical documentation for the machinery is available from:

Name: Matthew Cryans
Address: Unit 1C Upper Mantle Close, Chesterfield S45 9ED
Signed for & on behalf of: Crytec Limited
Place of issue: United Kingdom
Date of Issue: 24/08/2022
Name: Matthew Cryans
Function: Director
Signature: 

HAZARD SIGNAL WORD DEFINITIONS





	<p>This is the safety alert symbol. It is used to alert you to potential personal injury hazards. Obey all safety messages that follow this symbol to avoid possible injury or death.</p>
 DANGER	<p>DANGER indicates an imminently hazardous situation which, if not avoided, will result in death or serious injury.</p>
 WARNING	<p>WARNING indicates a potentially hazardous situation which, if not avoid, could result in death or serious injury.</p>
 CAUTION	<p>CAUTION indicates a potentially hazardous situation which, if not avoid, may result in minor or moderate injury.</p>
 CAUTION	<p>CAUTION used without the safety alert symbol indicates a potentially hazardous situation which, if not avoided, may result in property damage.</p>

TABLE OF CONTENTS

Part I. Introduction

About Your Grinder	4
Safety Decal Locations.....	5
Safety Decals	6
Receiving Your Unit.....	7
Machine Component Identification	8

Part II. Operation

Operation:

1. Pre-Start Check List & Procedures	9
2. Starting the Grinder.....	12
3. Stopping the Engine.....	13
4. Grinding the Stump.....	14
5. Refueling.....	15
6. Storing the Machine.....	16

Part III. Maintenance and Repair

Maintenance (To be done by owner or Rental Dealer)	19
1. Belt Tension Adjustment	21
2. Stop-Switch Adjustment	22
3. Installing Teeth	22
4. Schedule	24
Specifications	25

Part IV: Important Safety Information

Summary of Important Safety Information	26
Special Safety Information on Static Electricity	29

Parts Explosion	30
------------------------------	----

Warranty	32
-----------------------	----

ABOUT YOUR GRINDER

Owner/Operator/Renter Training

Read and follow all instructions and safety precautions presented throughout this manual. A summary of important safety information can be found at the end of the manual. Keep this manual for reference and review. *If the owner of this unit is different than the operator, give a copy of this manual to any operator to read.*

Rental Companies

All persons to whom you rent/loan this grinder must have access to this manual and read it. Check the tube on the side of the unit to make sure a manual is inside. Advise all persons who will operate the machine to read it. You should also provide personal instruction on how to safely operate the grinder and remain available to answer any questions a renter/borrower might have. If videos are available, have renter watch training video.

Engine Instructions

For detailed engine operation and maintenance information, always refer to the engine4 Owner's Manual furnished with the grinder.

Product Suitability

Before using, the user shall determine the suitability of this product for this intended use and assumes liability therein.

Your stump grinder can be used to remove many tree stumps and exposed root systems close to ground level. By moving the blade in sweeping movements laterally over the top and front of the stump, you can gradually grind it away. Make sure you completely read and understand this manual before using the grinder for the first time. If you have any question, contact your retail or rental dealer or manufacturer.

⚠️ WARNING: Never attempt to cut on a slope exceeding 15°

Exercise caution when cutting stumps on an incline, as the machine may shift or slide unpredictably. Never attempt to cut with the machine uphill or downhill from you as it may slide toward you or you may fall toward the machine. Cut only on a slope from the side.

The supplier is constantly improving its products. The specifications outlined herein are subject to change without prior notice or obligation. The purchaser and/or user shall assume liability for any modification and/or alterations of this equipment from original design and manufacturer.

Warranty Registration

Please fill out and submit the warranty registration card so that we have your contact information for any future product literature or replacement parts you may need.

SAFETY DECAL LOCATIONS

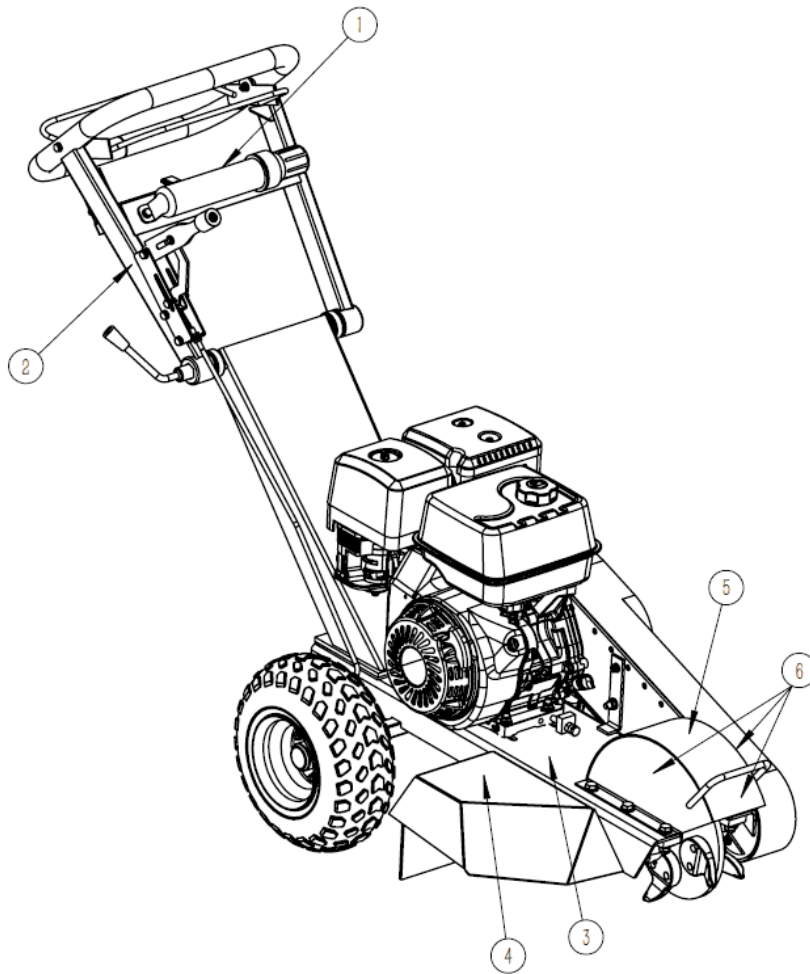

Reference #	Description
1	Control Panel Operator Hazard
2	Brake Identification
3	Poisonous Gas Hazard
4	Flying Debris Hazard
5	Flying Debris Hazard
6	Amputation and Entanglement Hazard

WARNING

ALWAYS make sure safety labels are in place and in good condition, If a safety label is missing or not legible, order new labels.

SAFETY DECALS

MACHINE COMPONENT IDENTIFICATION

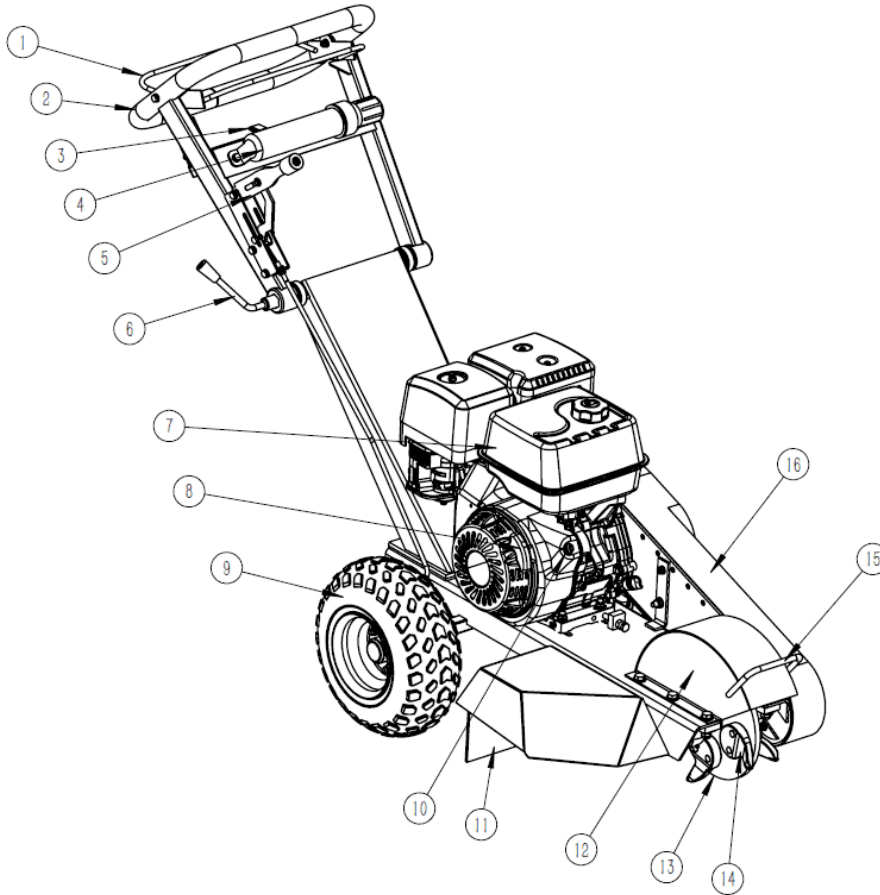

Reference #	Description
1	Operator Presence Handle Bar
2	Handle Bar
3	Throttle Control Lever
4	Manual Holder
5	Adjustable Brake Lever
6	Clamp Handle
7	Engine
8	Starter Grip
9	Wheel
10	Engine On/Off Switch
11	Rubber Baffle
12	Cutter Guard
13	Cutter Wheel
14	Cutter Teeth
15	Front Handle
16	Belt Cover

OPERATION

1. Pre-Start Check List & Procedures

⚠ CAUTION:

Add engine crankcase oil. A new engine is shipped without oil. You must add the correct amount of oil to engine crankcase or engine will be damaged beyond repair.

Before starting the engine you will want to make sure you have completed the following:

1. Marking Underground Utilities.
2. Checking Controls.
3. Checking Cutting Teeth.
4. Checking/Adding Oil.
5. Filling Stump Grinder Gasoline Tank.
6. Inspecting Fuel System for Leaks.
7. Locking Handle Bar.
8. Wearing Personal Protection.
9. Trimming Stump with Saw.
10. Clearing Area of People and Objects.
11. Working During Daylight.

Each of these procedures is discussed in detail below.

Check Controls	All guards are in place and tight. Operator presence bar switch is free moving. Inspect tires and rims for looseness, damage, and tire inflation.
Check cutting teeth	Inspect cutting teeth for tightness and sharpness. Only use factory-approved parts for repair.
Check/Add oil	Check the oil level using the dipstick and add oil as needed. Using a funnel, add oil up to the FULL mark on the dipstick with the recommended oil type for your engine and expected ambient conditions. (See engine Owner's Manual for oil type and capacity, and more detailed oil check/fill instructions). ⚠ WARNING: Burn Hazard Never open oil fill port while engine is running. Hot oil can spray over face and body.
Fill stump grinder gasoline tank	Check the gasoline level in the engine's fuel tank. If needed, fill tank with fresh unleaded gasoline from a portable container, after first reading the warnings and instruction below. - DO NOT fill the gas tank to the top. Gasoline may spill when operating on a slope. - DO NOT overfill the gasoline tank. Allow at least 1" of empty space below the fill neck to allow for fuel expansion. ⚠ WARNING: Gasoline fire/explosion hazard Gasoline is highly flammable and explosive. Heat, sparks and flames can ignite gasoline vapors, which can become widespread during fueling. A flash fire ignition and/or explosion could result and cause serious injury or death. The following conditions could result in gasoline ignition/explosion: <ul style="list-style-type: none"> ● Gas vapor collection inside enclosures. ● Static electric sparks.

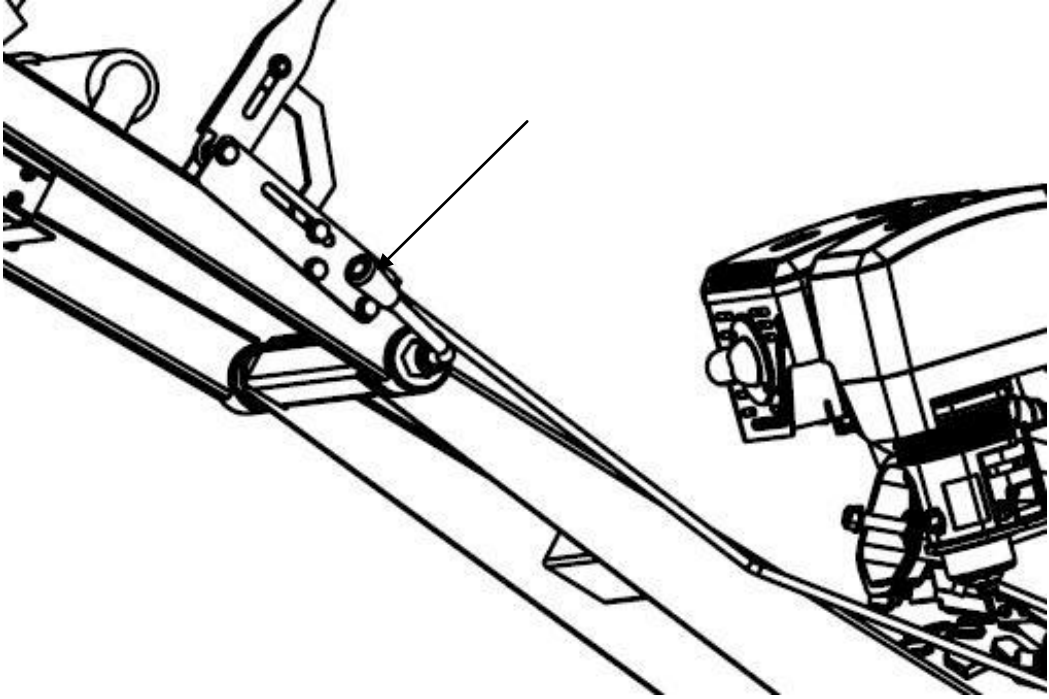
	<ul style="list-style-type: none"> • Sparks from electric wiring, batteries, or running engines. • Sources of heat (such as a hot engine or exhaust). • Open flames, including pilot lights.
<p>Inspect Fuel System/Check for Leaks</p>	<p>Inspect fuel system & check for leaks BEFORE starting grinder.</p> <p>▲WARNING: Fuel leak hazard</p> <p>A leaking fuel line no matter how small can be the source of a fire or explosion when starting or operating the engine.</p> <ul style="list-style-type: none"> • Inspect the entire fuel system. Look for: Signs of leaks or deterioration, chafed or spongy fuel hose, loose connections, loose or missing fuel hose clamps, damaged gasoline tank, or defective gasoline shut-off valve. <p>If grinder is in an enclosed area and you smell gas, DO NOT start engine! DO NOT light a match. DO NOT flip on an electrical switch.</p> <p>Exit area immediately leaving doors open and call fire department.</p>
<p>Locking Handle Bar</p>	<p>Handle is capable of folding when not in use.</p> 

Personal Protection	<p>Use approved protective clothing and approved protective equipment when using the machine.</p> <ul style="list-style-type: none"> • Always wear safety glasses with side shields and a full-face shield. • The use of ear plugs or other hearing protection device is also recommended for persons working within 15-20 feet of the running grinder for longer than a few minutes. Hearing can be damaged from prolonged, close- range exposure to the type of noise produced by this grinder. • Wear long pants to protect legs from sparks, hot engine and flying debris. • Never wear jewelry or loose-fitting clothing when starting or operating the grinder or any mechanical device. Loose or dangling apparel, jewelry or hair can become entangled in moving parts.
Trim Stump with Saw	Cut or trim the stump preferably to ground level using a power saw.
Clear Area	Dig away the earth and remove any stones near the tree stump or roots that may interfere with your work.
Working During Daylight Hours	Only use the machine in daylight or in well-lit conditions. Never operate the grinder after dark.

2. Starting the Grinder

After you have completed the pre-start checking list and procedures, you are ready to start the grinder.

The following directions details how to start the engine of your grinder.

⚠ WARNING:

Never attempt to use the grinder without proper protective equipment, particularly eye protection and a full-face shield.

To start the grinder:

Note: For additional engine starting instructions see your gasoline engine manual.

- Lock handle in the upright position.
- Place stump grinder into position with cutting wheel near the front-top edge of the stump.
- Use brake lever on handle to lock the wheel brake.

Note: For tighter brake adjustment, turn knob on top of brake lever. (See Maintenance & Repair sections for instructions).

⚠ WARNING:

Stay in the OPERATOR POSITION (Behind the machine) while actuating controls. Never leave grinder unattended.

- For cold engine, mover choke lever to the CLOSED position. To restart a warm engine, leave choke lever in OPEN position.
- Turn engine switch to the ON position.
- Grip operator presence bar and handle bar together in left hand.

⚠ WARNING:

A rotating cutting wheel is very dangerous. Stay at the controls and keep others away until you are sure the blades has come to a complete stop.

- Pull the starter grip lightly until you feel resistance, then pull briskly. Return the starter grip gently. If the choke lever was moved to the CLOSED position to start the engine, gradually move it to the OPEN position as the engine warms up.
- If engine does not start, repeat steps 5-7.
- Press down on handle bar to lift cutter wheel off the ground.
- Grip throttle control lever and handle bar together in right hand. Centrifugal clutch will engage and cutter wheel will begin to rotate.

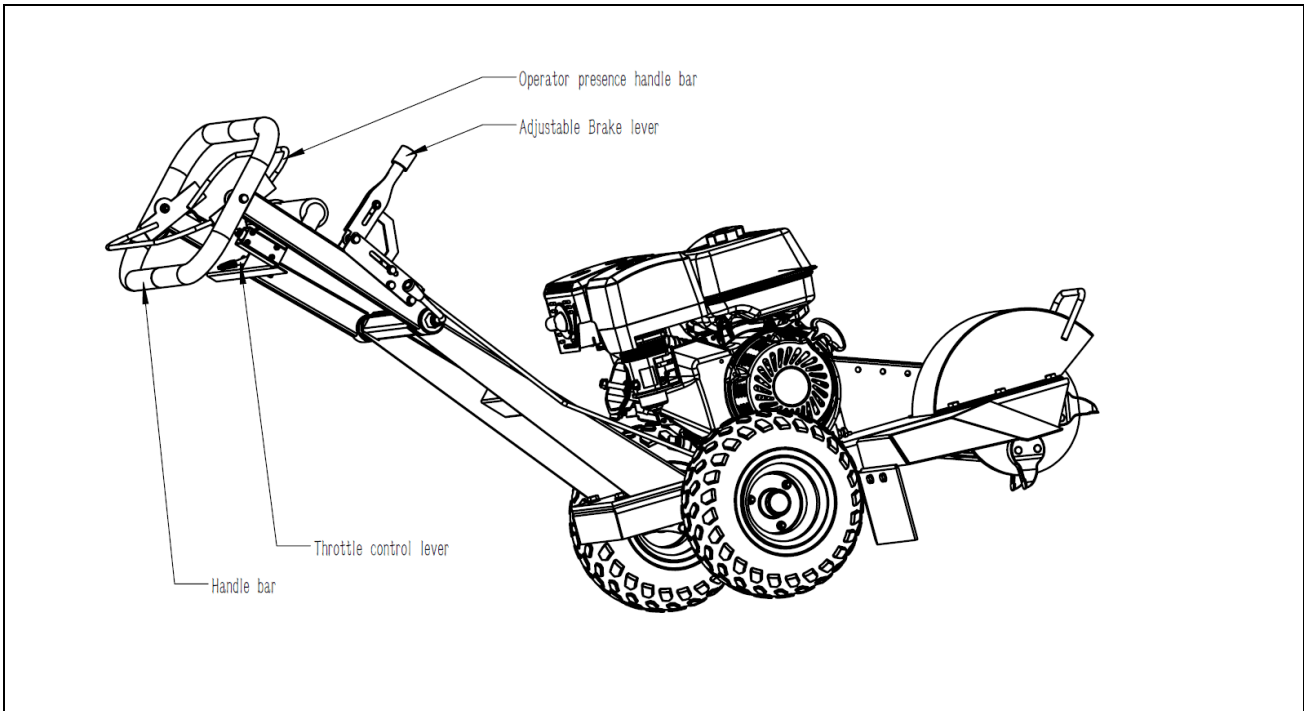

3. Stopping the Engine

Stop the engine using the following steps:

- While holding blade off ground, release the operator presence bar. The engine will stop. Wait until the blade completely stops. Lower the blade so it is resting against the ground.
- Make sure brake is set before leaving the controls, particularly if you are on an incline.
- Turn engine switch to OFF position.
- Allow the engine to cool for at least 5 minutes before releasing brake and moving to storage or transporting. A hot engine can be a fire hazard.

4. Grinding the Stump

⚠ WARNING: Flying Debris Hazard

Stones, chips, and debris can cause serious injury or property damage.

Debris can fly 75 ft in any direction out of the chute. They can bounce off any fixed objects as well and hit operator, bystanders or breakable objects.

- Set/engage the brake.
- Pivot the grinder toward the side of the stump, with a fairly light touch feed straight into the stump. As soon as you feed in, start to swing to the side until you feel the wheel drop off the edge of the stump. Change direction and swing back the other way until you feel it reach the other edge of the stump. As you swing to the side listen to the engine. Provide enough feed to give it a moderate load. If you hear any belt or clutch squealing you are pushing too hard. If you can not swing it to the side, raise the grinder up.

You can cut roots off by plunging straight through them.

⚠ WARNING: Rotating cutter wheel

Keep hands and feet away. Contact with wheel rotating teeth will cause serious personal injury.

- When grinding larger stumps, chips may begin to build up under the wheel.
- Release brake and pull machine towards you so that the "chip pile" is directly under the cutting wheel.
- Drop cutter wheel down on "Chip pile", material will be discharged from machine area.

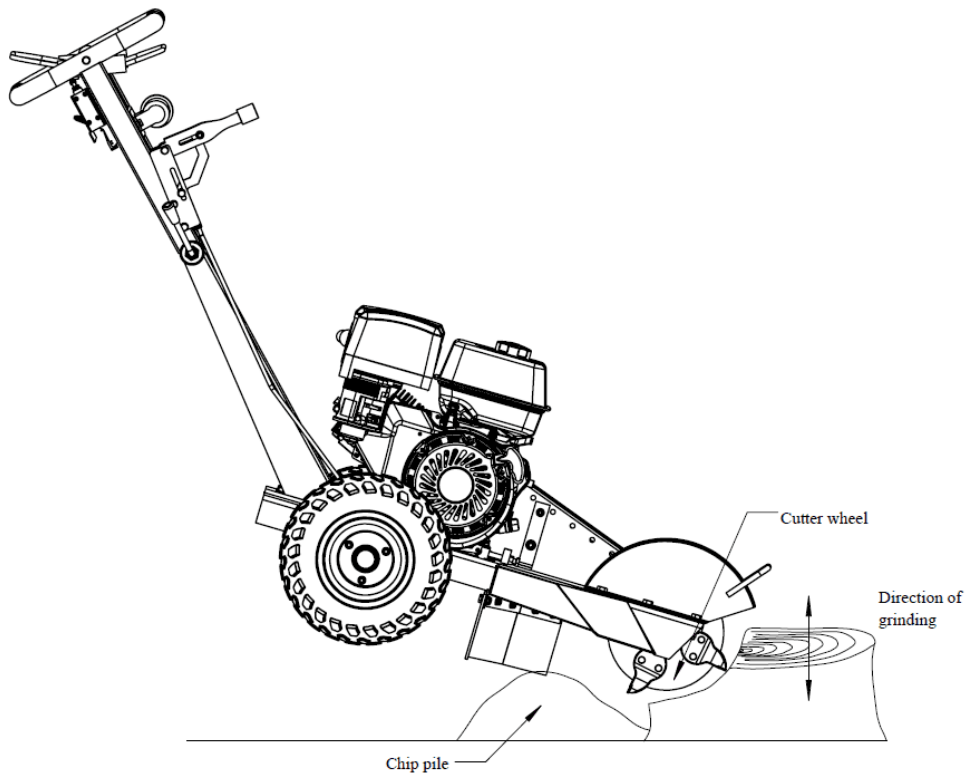

⚠ WARNING: Flying Debris Hazard

Stones, chips, and debris can cause serious injury or property damage.

Debris can fly 75 ft in any direction out of the chute. They can bounce off any fixed objects as well and hit operator, bystanders or breakable objects.

- On these large stumps, DO NOT allow grinder wheels to drop into stump hole. If a hole is in the way of your progress, fill it with chips or change position.

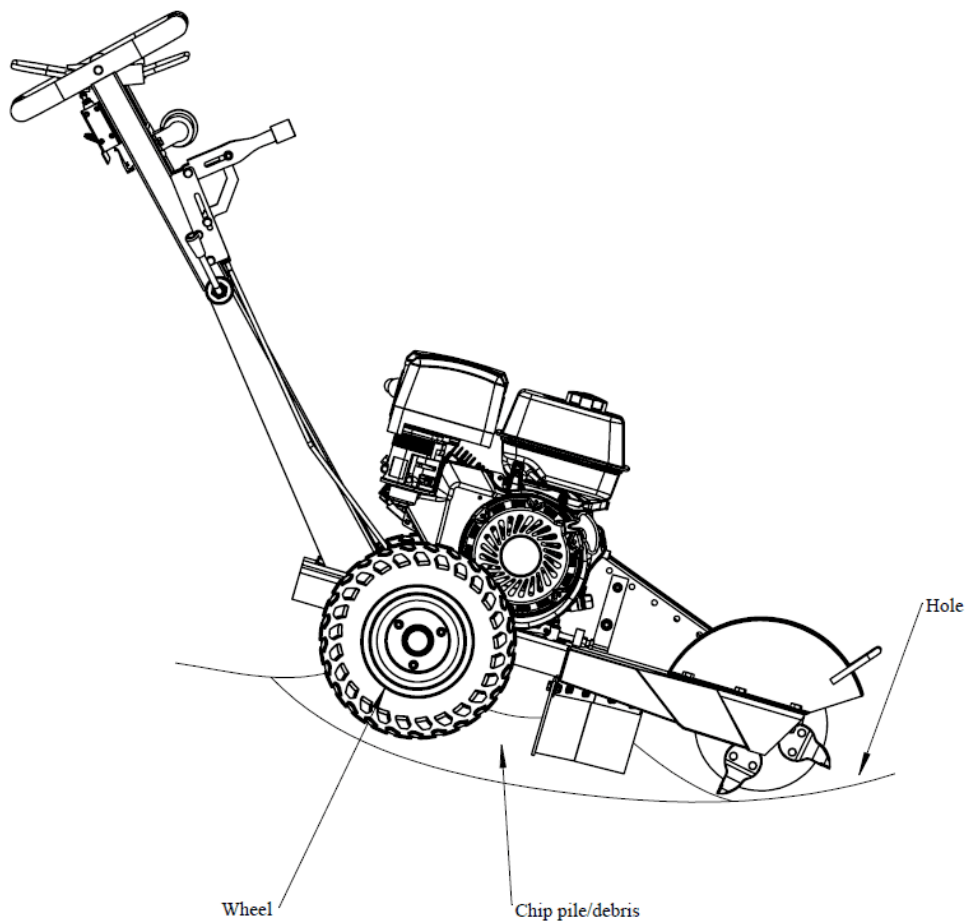

⚠ WARNING:

Stop engine and set brake before leaving operator's position. KEEP BRAKE ENGAGED except when changing locations.

- When finished, stop the engine.
- Pull machine away from stump, and rack chips away from stump.

5. Refueling

- Before removing gas cap, turn engine off and allow to cool for at least two minutes.
- Note: A running or hot engine can ignite fuel.
- Remove grinder gasoline cap.
 - Add gasoline through the fill opening
 - Use only an portable gasoline container to transfer the gasoline to the grinder's tank.
 - Be aware of safety warning and instructions below for avoiding static electric caused fires.
 - Do not overfill.

⚠ WARNING: Static electric spark hazard

A static electric spark can explosively ignite gasoline vapor, resulting in a flash fire that could cause serious injury or death.

See "Special Safety Information on Static Electricity" at end of this manual.

- Clean up gasoline spills / splashes immediately.

- If possible, move the grinder away from spilled gasoline on the ground.
 - Wipe up spilled gasoline, and wait 5 minutes for excess gasoline to evaporate before starting engine.
 - Gasoline soaked rags are flammable and should be disposed of properly.
 - If gasoline is spilled on your skin or clothes, change clothes and wash skin immediately.
- Replace gasoline cap securely before starting engine.
 - Store extra gasoline in a cool, dry place in an tightly sealed container.
 - Filling towable units or portable containers at service stations:
- Even if you have a towable unit, avoid static electric sparking while filling the gasoline tank:
- Never fill the grinder's gas tank directly from the fuel pump. The grinder's tank is not grounded and high velocity flow from the pump can cause static electricity build-up. Use an portable container to transfer gas to the grinder's tank.
 - Use a portable container made of metal or conductive plastic. This is preferred because it dissipates static charge to ground more readily.
 - Never fill a portable gas container while it is sitting inside a vehicle, trailer, trunk, or pick-up truck bed. ALWAYS place container on the ground to be filled.
 - Keep nozzle in contact with container while filing. Do not use a nozzle lock-open device.

6. Storing the Machine

When you are finished using the grinder and it has cooled, you must:

- Cool engine before storage.
- Clean the grinder.
- Inspect for worn or damaged parts.
- Choose covered storage location.
- Prevent accidental starting.
- Plan on exercising the engine at least monthly unless the grinder is prepared for long term storage.

Detailed instructions are provided below.

Cool Engine	Let engine cool for at least 5 minutes before storing. A hot engine can be a fire hazard.
Clean Grinder	Clean all grease, dirt, mud and other foreign matter from the machine. Touch up paint damage to prevent rust.
Inspect Grinder	Inspect the machine for worn or damaged parts and tighten any nuts or screws that may have become loose. Pay particular attention to the cutting teeth.
Choose a Storage Location	Store the grinder in a location that is: <ul style="list-style-type: none"> ● Clean and dry ● Away from sources of heat, open flames, sparks, or pilot lights, even if the grinder's gas tank is empty. Residual gasoline could ignite. ● Away from extreme high or low temperatures. ● Cover it for extra protection. ●
Remove Spark Plug	Remove spark plug, in order to ensure the grinder cannot be started in a storage location or by untrained persons or children.
Start Grinder Every 4 Weeks	The grinder should be started regularly. At least every 4 weeks, start

	<p>the engine and let it run for 10 to 15 minutes.</p> <p>Monthly exercising of the grinder will dry out any moisture that has accumulated, lubricate cylinders, and clean out old gas in the carburetor. Moisture, old gas, and dry mechanical parts cause deterioration in stored engines.</p>
<p>Prepare Engine for Long Term (Seasonal) Storage if needed</p>	<p>If you will not be able to start the grinder regularly, you must prepare the engine for long term storage to prevent gum deposits from forming and causing malfunction of the engine.</p> <p>Prepare engine for long term storage by:</p> <ul style="list-style-type: none"> ● Removing all gasoline from the tank and carburetor <p><u>OR</u></p> <ul style="list-style-type: none"> ● Adding fuel stabilizer to the gasoline (following manufacturer's instructions) <p>Fuel stabilizer steps:</p> <ol style="list-style-type: none"> 1. Ensure gas tank is full. 2. Add fuel stabilizer to fuel tank. 3. Run engine at least 10 minutes after adding stabilizer to allow it to enter the fuel system. 4. Shut off engine. 5. Disconnect spark plug wire and remove spark plug. 6. Add one teaspoon oil through spark plug hole. 7. Place rag over spark plug hole and turn starter (or pull the recoil) a few times to lubricate the combustion chamber. 8. Replace spark plug, but do not reconnect the spark plug wire. <p>⚠ WARNING: Gasoline fire / explosion hazard</p> <p>Gasoline is highly flammable and explosive. Drain the fuel into an approved container OUTDOORS and far away from open flame. NEVER store an engine with fuel in the tank indoors or in poorly ventilated spaces where fuel vapor can come in contact with</p> <ul style="list-style-type: none"> ● Static electric sparks. ● Sparks from electric wiring, batteries, or running engines. ● Sources of heat (such as a hot engine or exhaust). ● Open flames, including pilot lights.

! WARNING !

ALWAYS shut off the engine, make sure the engine is cool, and disconnect the spark plug before cleaning, adjusting, or servicing the grinder. Make sure all guards and shields are replaced before using.

MAINTENANCE

Perform regular	Perform periodic maintenance as directed in this manual to keep the
-----------------	---

Maintenance	grinder in safe working condition.												
Follow Safety Rules	<p>Read and follow these safety rules whenever you will be servicing the grinder:</p> <ul style="list-style-type: none"> • Turn off grinder. Always turn off grinder and remove spark plug or spark plug wire before working on the engine or grinder to prevent accidental starting. • Replace guards/shields. Make sure all guards and shields are replaced after servicing the grinder. • Burns. Muffler will be hot even after unit is stopped. Allow unit to cool before servicing. • Repair. Major service, including the installation or replacement of parts, should be performed only by a qualified electrical service technician. • Replacement parts. If a part needs replacement, only use factory approved repair parts. Replacement parts that do not meet specifications may result in a safety hazard or poor operation of the grinder and will void the warranty. 												
Perform Engine Maintenance	<p>Perform engine maintenance as specified in the engine owner's manual.</p> <p>Engine maintenance items include:</p> <ul style="list-style-type: none"> • Oil and oil filter changing • Air filter check/replacement • Spark plug cleaning and replacement • Fuel filter check/replacement • Fuel tank cleaning. 												
Inspect Fuel System / Check for Leaks	<p>Inspect the fuel system and check for leaks on a regular basis.</p> <p>Look for: signs of leaks or deterioration, chafed or spongy fuel hose, loose connections, loose or missing fuel hose clamps, damaged gasoline tank, or defective gasoline shut-off valve.</p>												
Lubricate	<p>Cutter shaft bearings should be greased.</p> <p>The cutter shaft bearing is greased by pumping grease into zerks located on the housing of the bearing. Lubricate after every 20 hours of use.</p> <table border="1" data-bbox="475 1525 1158 1823"> <thead> <tr> <th colspan="2">Grease Specifications</th> </tr> </thead> <tbody> <tr> <td>Soap Type</td> <td>Lithium Complex</td> </tr> <tr> <td>NLGI Grade</td> <td>#2</td> </tr> <tr> <td>Dropping Point</td> <td>230°C (446°F)</td> </tr> <tr> <td>Additives</td> <td>Corrosion and Oxidation inhibitors, EP optional</td> </tr> <tr> <td>Viscosity Index</td> <td>80 Minimum</td> </tr> </tbody> </table>	Grease Specifications		Soap Type	Lithium Complex	NLGI Grade	#2	Dropping Point	230°C (446°F)	Additives	Corrosion and Oxidation inhibitors, EP optional	Viscosity Index	80 Minimum
Grease Specifications													
Soap Type	Lithium Complex												
NLGI Grade	#2												
Dropping Point	230°C (446°F)												
Additives	Corrosion and Oxidation inhibitors, EP optional												
Viscosity Index	80 Minimum												
Check and Adjust Brake	<p>Check that the brake is functioning properly.</p> <ul style="list-style-type: none"> • Lock the brake, push down on handle bar so that cutter wheel is off the ground. • Push or pull the grinder- if the brake is loose, the wheel will 												

rotate.

To adjust braking tension:

- Unscrew set screw.
- Turn knob clockwise to increase tension or counter-clockwise to decrease tension.
- Once you have set the brake to the proper tension, tighten set screw to lock adjustment knob.

Belt Tension Adjustment

Note: Belt tension and alignment are inter-related. Do not adjust one without checking the other.

- Remove belt guard.
- Loosen (4) engine base (mount) bolts.
- Loosen lock nuts on tension bolt and alignment bolt.
- Turn tension bolt clockwise to increase belt tension and counterclockwise to decrease belt tension.
- Check that the pulleys are aligned using a straight edge. To achieve proper pulley alignment you may need to adjust the alignment bolt. This bolt will serve as an adjustment point to counter the tension in the belts, which may cause the engine pulley to be misaligned with the cutter wheel pulley. Note: Set screws in pulley have a torque specification of 17 ft/lbs.
- Belt tension is proper when a 5 to 7lbs force will deflect the belt 1/4" at the midpoint.
- Retighten all loosened nuts and bolts.
- Reassemble belt guard.

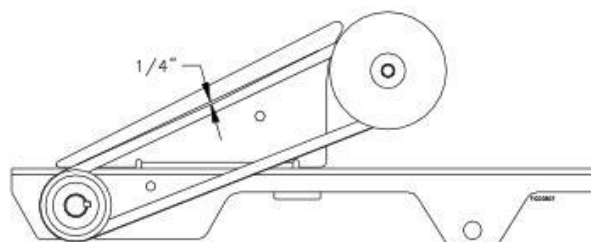
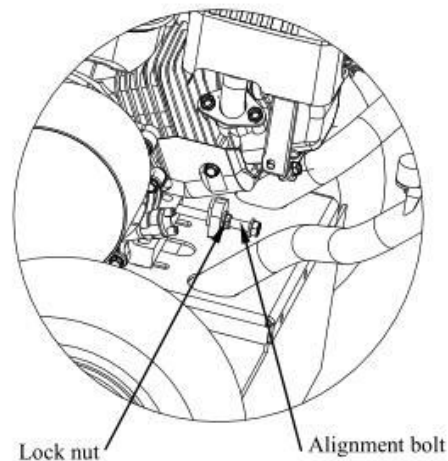
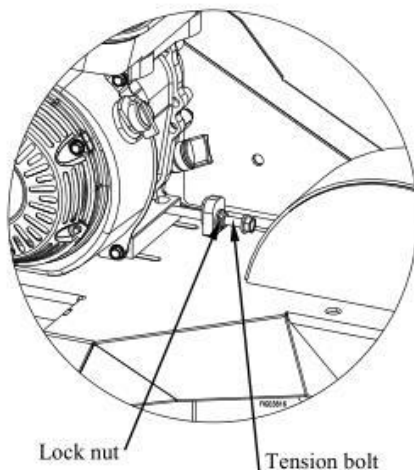

Stop-Switch Adjustment

⚠ WARNING:

Never attempt to alter, modify or override this switch.

If stop-switch ever needs to be replaced or adjusted follow the below directions.

1. Loosen Hex Nut.
2. Turn the Linkage Bolt clockwise to lower or counter-clockwise to raise the point of interaction with Stop Switch. To set the proper interaction distance, grip the Operator Presence Bar & Handle Bar together and lower the Linkage Bolt onto the Switch Button until the switch button cannot be depressed any further. Then raise the linkage bolt one turn (counterclockwise).
3. Tighten Hex Nut.
4. Verify operability of stop switch before operating machine by releasing the operator presence bar next to the handle bar. You should hear a "CLICK", signifying that the Linkage Bolt has been adjusted properly.

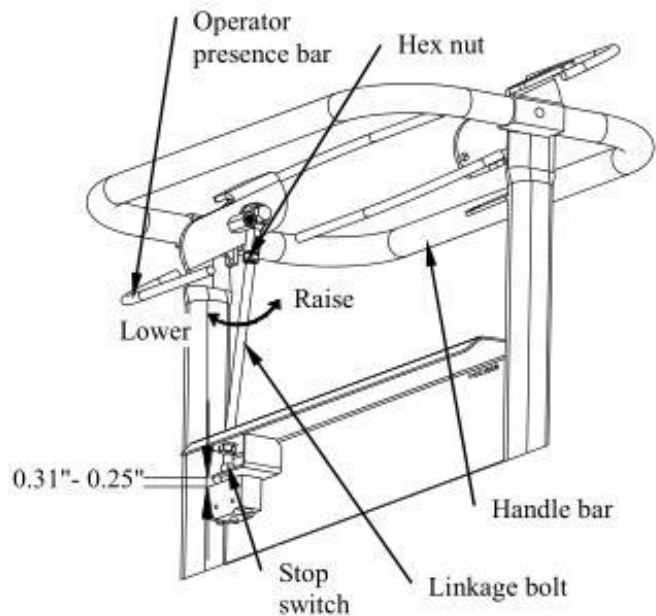

Installing Teeth

Among the most critical elements of the stump grinder is the cutting wheel. It is also the most subject to damage and wear. In the course of grinding stumps it not only makes contact with the wood, but also encounters numerous abrasives and objects in the stump's environment, such as dirt, stones, large rocks and buried scrap.

The loss and wear of cutting teeth can significantly impair the efficiency and performance of the stump grinder. Therefore, it is important to make frequent inspections of the condition of all the cutting teeth and to replace any damaged or worn teeth

Installing Teeth

Thread in the bolt through the cutter wheel and into the teeth as shown, then tighten. Bolt should be torque to 60ft/lbs.

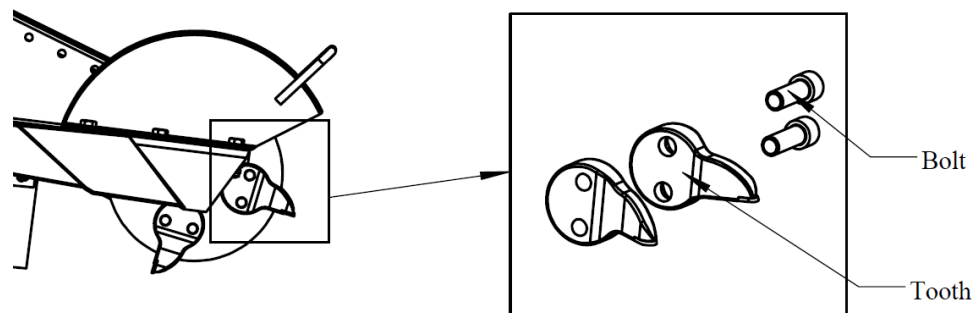

Maintenance Schedule

⚠ CAUTION:

Before attempting any maintenance, be sure that the engine is shut off, the spark plug wire is removed, and the engine is cool to the touch!

Item (What to check or action req'd)	Daily	Each Use	10 hours	20 hours	40 hours
Bearing, Shaft-Grease				X	
Belt Tension-Tension					X
Bolts-Tightness			X		
Engine	See manual				
Gasoline-Amount		X			
Safety Switch-Operation		X			
Warning Decals-Legible	X				
Tires, Flaps-Condition	X				
Wires, Cables-Condition		X			
Cutter Teeth-Sharpness		X			

IMPORTANT:

If a part needs replacement, only use parts that meet the manufacturer's specifications. Replacement parts that do not meet specifications may result in a safety hazard or poor operation of the grinder.

Specifications

Engine Option	
Maker	Honda, B&S, Loncin, Ducar, Jiangdong
Model	GX200, XR950, G200F
CC Rating	390cc
General	
Weight	
Length	
Height	
Width	
RPM Operating	3600 RPM
Type of Fuel	Gasoline
Starting	Recoil
Oil Sensor	Yes
Wheel	145/70-6
Cutter Wheel	
Diameter	9.45" (240mm)
Thickness	4.72" (12mm)
Bearings	
Cutter Wheel RPM	
Drive	Direct Belt Drive
	17x1346Li V-belt
	Centrifugal Clutch
Cutting Capacity	
Above Grade	10" (250mm)
Below Grade	9" (230mm)
Stump Diameter	No Limit
Teeth, Carbide Tips	
Cutter Type	Wood
Steel Type	42CrMo
Steel Hardness	HRC40-42
Weight	1.59 lbs
Length	4-1/4"
Width	2-13/16"
Tip Length	1-1/2"

Summary of Import Safety Information

This section provides a summary of the various safety procedures and measures that have been presented throughout the manual. Keep this summary handy and refer to it to refresh your memory about how to safely use your grinder.

! WARNING !

Carefully read and make sure you understand the following safety information before using the grinder. Improper use or maintenance of the grinder can result in serious injury or death from fire/explosion, carbon monoxide poisoning, lacerations, entanglement or burns. Damage can also occur to windows, siding, vehicles, and bystanders from chips and debris which can become projectiles.

General

- **Read manual.** Read this Owner's Manual and the engine Owner's Manual completely before attempting to use and service the grinder. Serious injury or death can result if safety instructions are not followed.
- **Instruct operators.** The grinder owner or rental company must instruct all operators in safe grinder set-up and operation. Do not allow anyone to operate the grinder who has not read the Owner's Manual and been instructed on its safe use. Make sure Owner's manual is within the attached storage tube on the grinder.
- **Adults only.** Only trained adults should operate and service the grinder. Do not let children operate.
- **Under the influence.** Never operate, or let anyone else operate, the grinder while under the influence of alcohol, drugs, or medication.
- **Intended use.** Carefully read about and understand the intended use of this grinder. Do not use for other purposes, as unforeseen hazards or equipment damage may result.
- **Controls and safety labels.** Learn how to use the machine and its controls safely. Understand and follow all safety labels.
- **Weather.** Never use in foul, bad or questionable weather, which causes a slippery ground condition.

Prohibition Against Modifications

Never modify or alter the grinder in any way. Modifications can create serious safety hazards and will also void the warranty.

- **Fuel/exhaust system.** Never modify the exhaust system, fuel tanks, or fuel lines. Carbon monoxide poisoning, fire, or explosion could result.
- **Guards.** Do not operate grinder unless all guards and cover shields, which prevent access to moving parts and pinch points, are in place. Failure to guard the power transmission mechanisms may result in serious injury or death.

Safety - Before Use

Know how to operate

- **Review safety rules.** Before use of this grinder, review the "Rules for Safe Operation."
- **Know how to operate.** Be thoroughly familiar with all controls and with the proper use of the equipment. Know how to stop the grinder quickly if needed.

Getting Ready

- **Flying debris.** Clear area of objects such as stones, toys, steel wire, etc. that could become caught in moving machine parts and ejected as a projectile.
- **Operate OUTSIDE only – dangerous carbon monoxide exhaust!** Grinders give off carbon monoxide exhaust, a

poisonous gas that can kill. You CANNOT smell it, see it, or taste it. ONLY run grinder OUTDOORS and at least 20 feet from the home, away from windows, vents and air intakes, to allow proper ventilation. If you start to feel sick, dizzy, or weak while using the grinder, shut off the engine and get to fresh air RIGHT AWAY. NEVER run grinder engine inside homes, garages, sheds, or other semi-enclosed spaces. These spaces can trap poisonous gases.

- **Cooling ventilation.** The grinder needs adequate, unobstructed flow of air to allow for proper cooling of engine and grinder head. Do not allow debris to accumulate and block airflow.
- **Transporting.** During transporting, take precautions to make sure stump grinder will not tip over and cause a fuel leak hazard.
- **Hot exhaust - fires.** Exhaust from engine can be extremely hot and cause fire. Position muffler at least 7 feet from combustible objects during operation.

Personal protective equipment

- **Hearing protection.** The use of ear plugs or other hearing protection device is recommended for those in close proximity to the grinder while it is operating.
- **Eye protection.** Wear ANSI approved eye protection when operating the grinder.
- **Face protection.** A helmet with a full face visor or mesh visor with protective glasses is recommended.
- **Loose / dangling.** Loose or dangling apparel, jewelry or hair can become entangled in moving parts. Never wear jewelry or loose-fitting clothing when operating the grinder.
- **Long pants.** Wear long, heavy-duty pants to protect legs from ejected materials.

Gasoline Safety

Gasoline is highly flammable and explosive. You can be burned or seriously injured when handling fuel. Use extreme care when handling gasoline:

- **Fuel outdoors.** Fill fuel tank outdoors – never indoors. Gasoline vapors can ignite if they collect inside an enclosure. Explosion can result.
- **Use approved container.** Never pump fuel directly into engine at gas station. Static charge can build and ignite fuel. Use an UL approved fuel container to transfer gas to the engine.
- **Running / hot engine.** A running engine is hot enough to ignite fuel. Never add fuel or remove gas cap if engine is running or still hot. Stop the engine and allow to cool at least two minutes before adding fuel.
- **Heat / flames / sparks.** Keep sources of heat, flame, or sparks away while adding fuel.
- **Don't fill to the top** DO NOT overfill the gas tank. Allow at least 1" of empty space below the fill neck to allow for fuel expansion and operation on slopes.
- **Don't fill to the top.** Do not fill the gas tank to the top. Gasoline may spill when operating on a slope.
- **Replace cap.** Replace gas cap securely before starting engine.
- **Spills.** Clean up fuel spills immediately. Move grinder away from spilled fuel on the ground. Wipe fuel off engine and wait 5 minutes for excess fuel to evaporate before starting engine. Gas soaked rags should be disposed of properly.
- **On skin / clothes.** If gasoline is spilled on your skin or clothes, change clothes and wash skin immediately.
- **Inspect fuel system.** Check fuel system on a regular basis. Look for signs of leaks, deterioration, chafed or spongy fuel hose, loose or missing fuel hose clamps, damaged fuel tank, or a defective fuel shut-off valve. Do not start grinder until needed repairs have been completed.
- **Gasoline storage.** Store gasoline in a cool, dry place in an UL-approved, tightly sealed container away from children.

Safety - During Use

- **Safety equipment / controls.** Always operate the grinder with all safety covers, guards, and barriers in place and in good working order, and all controls properly adjusted for safe operation.
- **Controls.** Stay in the OPERATOR POSITION while actuating controls.
- **Know how to stop.** Know how to stop the grinder quickly if needed by releasing the operator presence bar. If this does not work, do the following in order until unit is stopped. 1. Push the stop button on the control panel. 2. Use on/off switch on engine (or ignition switch on electric start models). 3. Engage full choke by flooding the engine.
- **"Kickback".** Machine can experience significant "kickback" when operating or first coming into contact with the stump.
- **Slipping/Falling.** Operating in wet or icy conditions could lead to losing your footing and slipping or falling.
- **Damaged.** Do not operate the grinder with damaged, missing, incorrectly adjusted, or broken parts.
- **Check for gas leak before starting.** After opening gasoline valve, smell for gas before starting engine. If you smell gas, DO NOT start engine. DO NOT light a match. DO NOT flip on an electrical switch. Exit area immediately and call fire department.
- **Carbon monoxide exhaust.** The running engine gives off carbon monoxide, a poisonous gas that can kill you. You CANNOT smell it, see it, or taste it. If you start to feel sick, dizzy, or weak while using the grinder, shut off the engine and get to fresh air RIGHT AWAY. See a doctor. You may have carbon monoxide poisoning.
- **Other exhaust dangers.** This product contains or emits chemicals known to the State of California to cause cancer, birth defects or other reproductive harm. Avoid inhalation of exhaust.
- **Smoking/sparks.** Never smoke near the running grinder, and never operate near sources of sparks or flames.
- **Hot muffler.** Never touch hot muffler or hot exhaust manifold. Exhaust and engine parts can be very hot and will burn you.
- **Machine's moving parts.** Keep hands, feet, and apparel away from drive belts, cutter wheel, and other moving parts. Never remove any drive belt or guard while the unit is operating. Contact with belt or rotating teeth will cause personal injury.
- **Refueling.** DO NOT refuel the engine until it has cooled at least two minutes.
- **Malfunction during operation.** Always shut the machine off if any unusual noise or vibration occurs.
- **Vibration.** Overexposure to machine vibration on a daily basis may lead to circulatory or nerve damage.
- **Adjusting / repairing.** Always turn off grinder and remove spark plug or spark plug wire before working on the grinder to prevent accidental starting.

Safety - After Use

- **Cool engine before storing.** Let engine cool for at least five minutes before storing. A hot engine can be a fire hazard.
- **Shut off fuel supply.** Make sure gasoline shut-off valve is in the OFF position.
- **Prevent accidental starting.** When grinder is not in use, remove key from starter (electric start engines) and secure in a safe location, or remove spark plug in order to ensure that grinder cannot be started in a storage location or by untrained persons.
- **Storage location.** Store the grinder in a dry location away from sources of heat, open flames, sparks or pilot lights – such as water heaters, space heaters, furnaces, clothes dryers, or other gas appliances – EVEN IF the grinder's gas tank is empty. Residual gasoline could ignite.
- **Exercise regularly.** Exercise grinder every four weeks to dry out moisture that accumulates in the windings. If grinder cannot be exercised on a regular basis, prepare grinder for long term storage.

Safety - Inspection / Maintenance

Inspect and maintain your grinder on a regular basis and repair as needed to keep it in safe working condition:

- **Turn off grinder.** Always turn off grinder and remove spark plug or spark plug wire before working on the engine or grinder to prevent accidental starting.

- **Replace guards / shields.** Make sure all guards and shields are replaced after servicing the grinder.
- **Burns.** Do not touch hot muffler. Muffler will be hot even if unit is stopped. Allow unit to cool before servicing.
- **Replacement parts.** If a part needs replacement, only use parts that meet the manufacturer's specifications. Replacement parts that do not meet specifications may result in a safety hazard or poor operation of the grinder and will void the warranty.

Special Safety Information on Static Electricity

Static electricity and filling gasoline:

Static electricity can initiate from ungrounded gasoline tanks or containers, from flowing gasoline, and from persons carrying a static electric charge

Static electricity on numerous occasions has explosively ignited gasoline vapors that were present during fueling processes, resulting in serious burns to nearby persons. To avoid static electricity while fueling, certain steps must be followed before and during the fueling process in order to minimize and safely dissipate static charge build-up.

Filling Portable Containers at Service Stations:

Use a portable container to fill grinder tank. Never fill the grinder's gas tank directly from the service station's fuel dispenser pump – the grinder's tank is not grounded and the high velocity flow of gasoline from a fuel pump can cause static electric build-up. Use an approved portable container to transfer gasoline to the grinder's tank.

- Use a portable container made of metal or conductive plastic. It will dissipate charge to ground more readily.
- Fill container on the ground. Never fill the portable gas container while it is sitting inside a vehicle, trailer, trunk, or pick-up truck bed. ALWAYS place container on the ground to be filled.
- Touch a grounded metal object before starting. Always dissipate static charge from your body before beginning the fueling process by touching a grounded metal object at a safe distance away from fuel sources.
- Keep nozzle in contact with container. Keep fuel dispenser nozzle in contact with the portable container at all times while filling at a service station. Do not use the nozzle lock-open device on the dispenser hose.

About static electricity and fueling

Many common objects can accumulate and retain a static electric charge. Objects made of non- conductive materials (e.g. plastics) easily accumulate and retain static electric charge, as can objects made of conductive material (e.g. metal, water) if they are not electrically grounded. The static electric charge on an object, such as a human body or plastic fuel tank/container, can reach as high as several thousand volts!

A static electric spark can be generated if the static electric charge stored on an object "jumps" to another, less charged object. Such a spark can ignite invisible gasoline vapors that are present during fueling situations.

Typical sources of static electric hazards during fueling

The following objects can accumulate a static electric charge and cause an ignition spark in typical fueling situations:

- Ungrounded tanks/containers. Any ungrounded fuel tank or container can accumulate a static electric charge as a result of contact with other objects or friction during transportation. This static electricity can discharge as a spark to the grounded gasoline dispenser nozzle, as the nozzle is first brought close to the tank/container at the beginning of the fueling process.
- Flowing gasoline. Most people are not aware that gasoline accumulates static electric charge while flowing through a hose or pipe. This charge then transfers to and accumulates in the gas tank or container that is being filled. The total amount of charge accumulation depends on the amount of gas pumped into the container, the speed with which it is pumped, and whether or not the tank/container is grounded. If sufficient static electric charge accumulates in the fuel tank or container during the fueling process, the tank/container may discharge a spark to the grounded gasoline dispenser nozzle.
- Persons. A person dispensing the gasoline can carry a static electric charge on their body, typically resulting from contact with their car seat or electronics. The static electricity can discharge as a spark between that person's hand and either the grounded dispenser nozzle or the fuel tank opening.

Exploded View

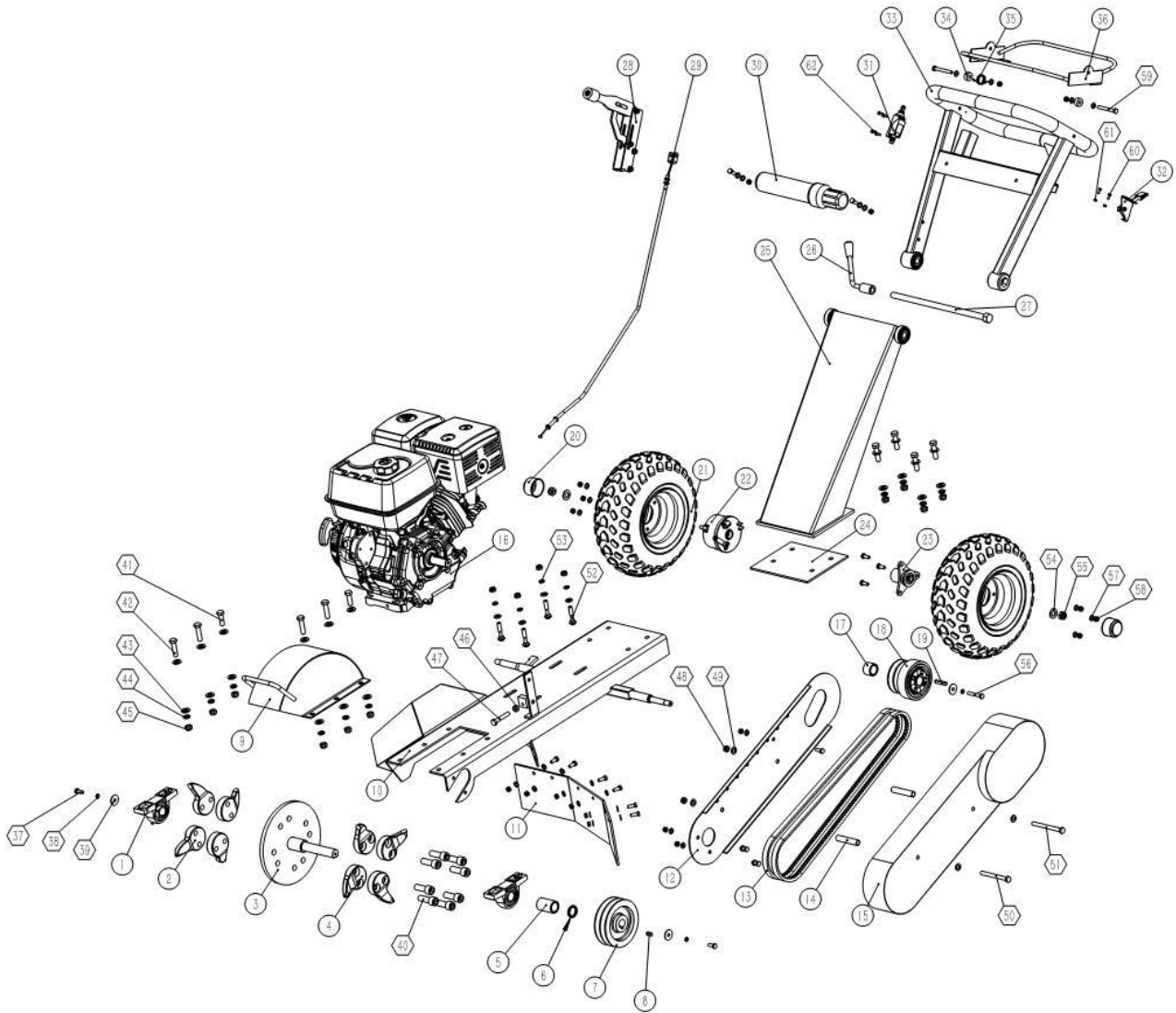

Parts List

Item	Description	Qty.	Item	Description	Qty
1	Bearing	2	32	Throttle Controller	1
2	Teeth-R	4	33	Handrail	1
3	Cutter Wheel	1	34	Spring Pad	2
4	Teeth-L	4	35	Torsion Spring	1
5	Axle Sleeve-L	1	36	Lever	1
6	Binding Ring	1	37	M8x20 Hex Bolt	16
7	Belt Pulley	1	38	Spring Washer 8	4
8	Key	1	39	Lock Ring	3
9	Wheel Cutter Guard	1	40	M16x45 Inner Hex Cylinder Head Bolt	8
10	Frame	1	41	M12x35 Hex Bolt	2
11	Rubber Baffle	1	42	M12x45 Hex Bolt	8
12	Inner Belt Guard	1	43	Flat Washer 12	20
13	Belt	2	44	Spring Washer 12	10
14	Bolt Locating Sleeve	2	45	M12 Hex Lock Nut	10
15	Belt Cover	1	46	M10 Hex Nut	1
16	Engine	1	47	M10x60 Hex Bolt	1
17	Crankshaft Sleeve	1	48	M10 Hex Lock Nut	6
18	Centrifugal Clutch	1	49	Flat Washer 10	8
19	Crankshaft Key	1	50	M10x100 Hex Bolt	1
20	Hub Cap	2	51	M10x110 Hex Bolt	1
21	Wheel	2	52	M10x50 Step Bolt	4
22	Drum Brake	1	53	Spring Washer 10	4
23	Flange	1	54	Flat Washer 14	2
24	Rubber Pad	1	55	M14 Hex Lock Nut	2
25	Handhold Assembly	1	56	M8x50 Hex Bolt	1
26	Clamp Handle	1	57	Flat Washer 8	31
27	Long Hexagon Bolt M16x360	1	58	M8 Hex Lock Nut	19
28	Brake Handle	1	59	M8x65 Hex Bolt	2
29	Brake Cable	1	60	M5x12 Hex Bolt	2
30	Manual Holder	1	61	M5 Hex Lock Nut	2
31	Switch	1	62	M5x12 Inner Hex Cylinder Head Bolt	4

Limited Warranty Policy

Dear Valued Customer:

The stump grinder you just purchased is built with the finest material and craftsmanship. Use this product properly and enjoy the benefits from its high performance. By purchasing our product, you show a desire for quality and durability. Like all mechanical equipment this unit requires a due amount of care. Treat this unit like the high quality piece of machinery it is. Neglect and improper handling may impair its performance.

Thoroughly read the instructions and understand the operation before using your product. Always contact our Product Support prior to having any service or warranty work performed, as some services performed by parties other than our approved service centers may void this warranty. This limited warranty is in lieu of any other warranty expressed or implied, written or oral and we assume no other responsibility or liability outside that expressed within this limited warranty.

	Consumer Warranty Period	Commercial Warranty Period
Weldments		
	2 years from date of purchase by user	2 years from date of purchase by user
Wear Parts		
	In addition to the normal warranty, we shall warrant some normal wear items from defects in material or workmanship for a period of 30 days from the date of purchase by user. Normal wear items covered under this warranty are limited to: tires, belts, grease zerks, bearings, teeth, bolts, clutches, switches, wires, cables. Routine maintenance items such as lubricants, clutch adjustments, tune ups are not covered under warranty.	
Engine		
	The engine warranty is covered under the terms and conditions as outlined by the engine manufacturer's warranty contained herein and is the sole responsibility of the engine manufacturer. Normal engine maintenance such as spark plugs, oil changes, air filters, adjustments, fuel system cleaning and obstruction due to build up is not covered by our limited warranty.	

“Consumer use” means personal residential household use by a consumer. **“Commercial use”** means all other uses, including, but not limited to, use for commercial, income producing or rental purposes or when purchased by a business. This limited warranty applies to the original purchaser of the equipment (verification of purchase, in the form of a receipt, is the responsibility of the buyer), is non-transferable, and covers parts and labor. Parts will be replaced or repaired at no charge, except when the equipment has failed due to lack of proper maintenance. If a part is no longer available, the part may be replaced with a similar part of equal function. Any misuse, abuse, alteration or improper installation or operations will void warranty. Determining whether a part is to be replaced or repaired is the sole decision of ours. We will not provide for replacement of complete products due to defective parts. Any costs incurred due to replacement or repair of items outside of a ours approved facility is the responsibility of the buyer and not covered under warranty. Transportation costs to and from service center and/or service calls are the responsibility of the customer.

This limited warranty specifically excludes the following; failure of parts due to damage caused by accident, fire, flood, windstorm, acts of God, applications not approved by our in writing, corrosion caused by chemicals, use of replacement parts which do not conform to manufacturer’s specifications, damage related to rodent and/or insect infestation and damage caused by vandalism. Additional exclusions: loss of running time, inconvenience, loss of income, or loss of use, including any implied warranty of merchantability of fitness for a specific use.

Also, outdoor power equipment needs periodic parts and service to perform well, and this limited warranty does not cover instances when normal use has exhausted the life of a component or the engine.

This limited warranty does not cover any personal injury or damage to surrounding property caused by failure of any part, misuse or inability to use the product. Alteration of the product, including safety features, shall void this limited warranty.

Repair or replacement of parts does not extend the warranty period. This limited warranty gives you specific legal rights. You may also have other rights that vary by state.

Please have model number, item number and serial number on hand prior to making a warranty claim or inquiry.