



WIRELESS SOIL MOISTURE & TEMPERATURE ADD-ON SENSOR USER GUIDE

LOWSA100SW



Thank you for purchasing the Logia Wireless Soil Moisture & Temperature Add-On Sensor. This User Guide is intended to provide you with guidelines to ensure that operation of this product is safe and does not pose risk to the user. Any use that does not conform to the guidelines described in this User Guide may void the limited warranty.

Please read all directions before using the product and retain this guide for reference. This product is intended for household use only. It is not intended for commercial use. This product is covered by a limited one-year warranty. Coverage is subject to limits and exclusions. See warranty for details.

SAFETY PRECAUTIONS

WARNING! Please read all safety precautions and instructions carefully before using this product. Failure to properly follow the guidelines established here could result in serious injury or damage to the product.

- Do not cover the ventilation holes with any items such as newspapers, curtains, etc.
- Do not clean the unit with abrasive or corrosive materials.
- Do not tamper, alter, or modify the device.
- Only use fresh new batteries in the product. Do not mix new and old batteries.
- This product is not a toy. Keep out of the reach of children.
- This product is designed for use in the home only as indication of air quality. This product is not to be used for medical purposes or for public information.
- Do not place the device near open flames or heat sources. Fire, electric shock, product damage, or injury might occur.
- Only use attachments or accessories with this product specified by the manufacturer.
- Do not submerge the unit in water. Dry the product with a soft cloth if liquid spills on it.
- Do not subject the unit to excessive force, shock, duct, extreme temperature, or humidity.
- This product is only suitable for mounting at height less than 6.6 ft. (2 m).
- Do not tamper with the unit's internal components. Tampering with the product will void the warranty.
- This product should not be placed in direct sunlight, rain, snow, or other weather conditions.
- When inserting the batteries, make sure that the positive and negative polarities match with the markings in the compartment.
- Do not mix standard, alkaline, and rechargeable batteries together.
- Dispose of old batteries responsibly and in accordance with local regulations.
- Do not subject your battery to high or low extreme temperatures or low air pressure at high altitude during use, storage, or transportation.
- Replacement of an old battery with an incorrect type of battery can result in damage to the product, leakage of flammable liquid or gas, or an explosion. Make sure to follow guidelines listed in the manual to properly replace the battery.

PRODUCT OVERVIEW

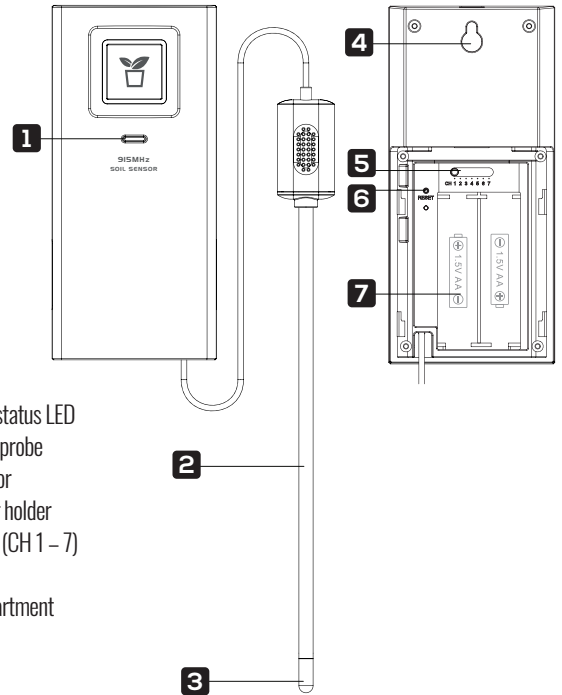

1. Transmission status LED
2. Metal sensing probe
3. Moisture sensor
4. Wall mounting holder
5. Channel slider (CH 1 - 7)
6. RESET button
7. Battery compartment

OPERATION

INSTALLING THE BATTERIES

1. Remove the battery door.
2. Use the channel slider to choose a channel.
NOTE: If there is more than one sensor in use, make sure to assign a different channel number to each one for measurements to properly display on main console.
3. Insert two (2) AA batteries (not included) into the battery compartment.
4. Place the battery door back on the compartment. The transmission status LED should light up if the batteries were inserted correctly.

PAIRING THE SENSOR TO MAIN DISPLAY CONSOLE

- After the sensor is powered on, it will enter pairing mode for 10 minutes.
- Make sure the display console (not included) is also on, and the two devices should automatically connect.
- Once connection is successful, the signal strength indicator and soil information will appear on the display console.
NOTE: To reassign a sensor, switch the channel using the channel slider, then use a pin to press the RESET button to restart the sensor.

SOIL TEMPERATURE & MOISTURE DISPLAY

The temperature of soil will display on the main display console once it is linked to the sensor. For soil moisture, the sensor measures the moisture of the soil in 16 points which is classified into 5 levels in the chart below.

NOTE: The accuracy of the sensor can be affected by the condition of the soil.

Points	Percentage	Level
1	0%	Very Dry
2	7%	
3	13%	
4	20%	
5	27%	Dry
6	33%	
7	40%	
8	47%	
9	53%	Damp
10	60%	
11	67%	
12	73%	
13	80%	Wet
14	87%	
15	93%	Very Wet
16	99%	

SELECTING SENSOR PLACEMENT

- The metal probe of the sensor should be inserted 4" (100 mm) deep into the soil.
- The sensor should be set up within 98.4' (30 m) of the display console to get a proper, clear transmission.

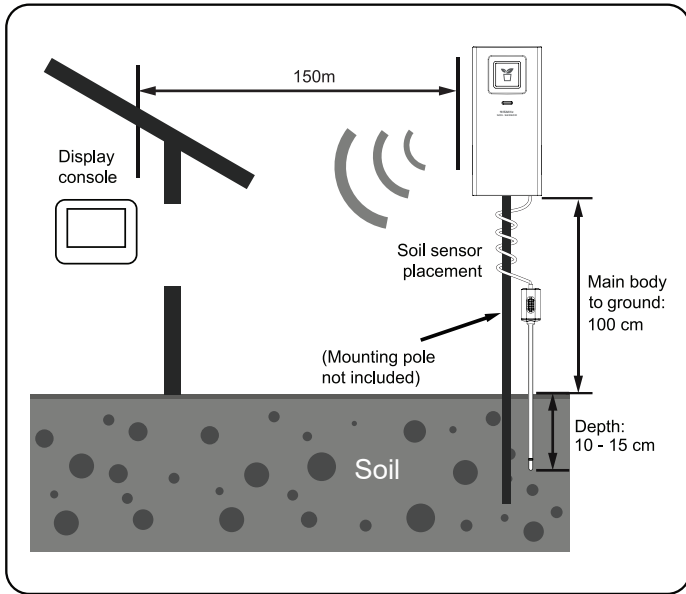

RESETTING THE SENSOR

- In case of malfunction, use a pin to press the RESET button to restart the sensor.

SPECIFICATIONS

Product type: Weather/environment sensor

Product length: 2.2"

Product width: 0.7"

Product height: 4.9"

Net weight (with batteries): 0.32 lbs.

Packaging length: 2.8"

Packaging width: 1.4"

Packaging height: 9.4"

Gross weight: 0.57 lbs.

Weather data: Soil temperature and moisture

RF frequency: 915 MHz

RF transmission range: 492'

Operating temperature range: -4 °F - 140 °F (-20 °C - 60 °C) (usage not recommended under freezing conditions)

Operating moisture range: 0% - 99%

Temperature accuracy:

23 °F ~ 31.8 °F ± 4 °F (-5 °C ~ -0.1 °C ± 2 °C)

32 °F ~ 104 °F ± 2 °F (0 °C ~ 40 °C ± 1 °C)

104.2 °F ~ 122 °F ± 4 °F (40.1 °C ~ 50 °C ± 2 °C)

Below 23 °F (-5 °C) or above 122 °F (50 °C)

Moisture accuracy: 0% - 99%

Number of channels: 7

Transmission interval: 60 seconds (fixed)

Power source required: Yes

Power source: 2 x AA 1.5 V batteries (not included)

Location: For indoor or outdoor use

Installation required: No

Adult assembly required: No

Additional tools required: No

Country of origin: China

Warranty included: Yes

Warranty length: 1 year

WARRANTY INFORMATION

Visit www.logiweatherstations.com to view our limited time warranty.

COMPATIBLE LOGIA WEATHER STATIONS

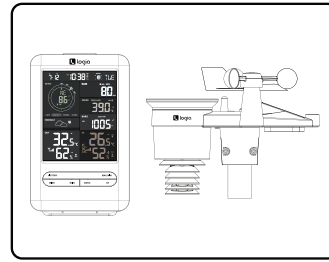

5-in-1 Wireless Weather Station with Wi-fi® and Solar Panel
Model #: LOWSC510SWB

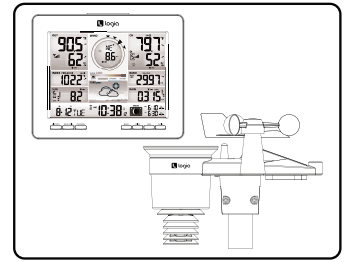

7-in-1 Wireless Weather Station with Wi-fi® and Solar Panel
Model #: LOWSC710SWB

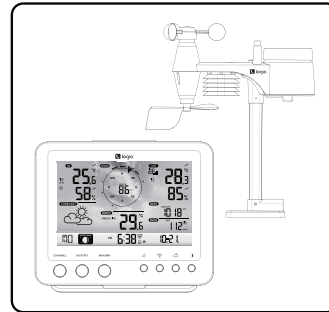

5-in-1 Wireless Weather Station with Wi-fi®
Model #: LOWSC510WB

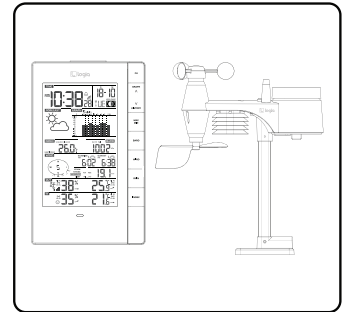

5-in-1 Wireless Weather Station with PC Data Sync
Model #: LOWSB510PB

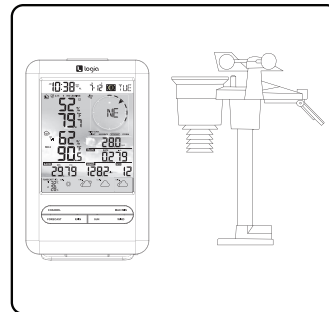

7-in-1 Wireless 4-Day Forecast Weather Station with Wi-fi® and Everlasting Solar Cell
Model #: LOWSC713SWB

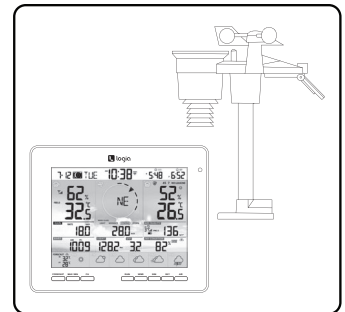

7-in-1 Wireless 6-Day Forecast Weather Station with Wi-fi® and Everlasting Solar Cell
Model #: LOWSC715FWB

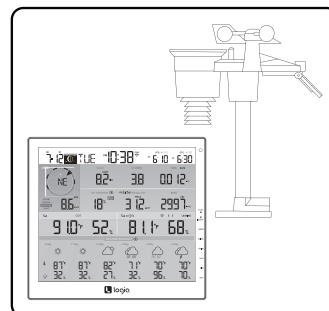

7-in-1 Wireless 6-Day Forecast Weather Station with Wi-fi®, Everlasting Solar Cell, and Ultra-Wide Display
Model #: LOWSC715FWB10

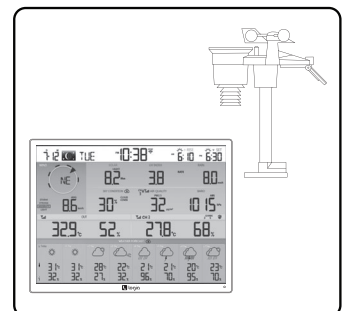

7-in-1 Wireless 8-Day Forecast Weather Station with Wi-fi®, Everlasting Solar Cell, and Ultra-Wide Display
Model #: LOWSC715FWB19

Visit www.logiweatherstations.com for the most updated list of compatible Logia weather stations.

QUESTIONS OR PROBLEMS? CONTACT US!

Email: info@supportcbp.com or call: 833-815-0568

LOGIA is a trademark of C&A IP Holdings LLC in the US, Canada, China, and the EU.

All other products, brand names, company names, and logos are trademarks of their respective owners, used merely to identify their respective products, and are not meant to connote any sponsorship, endorsement, or approval.

Distributed by C&A Marketing, Inc., 114 Tived Lane East, Edison, NJ 08837. Made in China.

© 2021, C&A IP Holdings LLC. All Rights Reserved.