

CineVision Pro Splicing UST ALR fixed frame projection screen.

USER MANUAL



Content

To Users	2
Safety Instructions	2
Packing Contact	4
Matters Needing Attention	6
Screen and projector compatibility	7
Operation Guide	10
Installation Steps	11
Screen Maintenance	20
Manufacturer's Warranty	21
Certificate	23
Product Warranty Card	23

To Users

Thank you for choosing the VIVIDSTORM projection screen.

Please read this manual carefully before using the product and keep it properly.

The manual of products, accessories, user interface, etc. in this description are schematic diagrams and are for reference only. Due to product updates, the actual product may be slightly different from the schematic diagram, please refer to the actual product.

Safety Instructions

For your security and interest, to ensure safe and correct use of this product, always comply with the following precautions to avoid dangerous situations and damage to your unit:

Safety Instructions



Shipping Instructions

Please use this product's original packaging or same materials to transport this product.



This symbol reminds the user to some important information related to operation and maintenance.

Please read this information carefully to avoid incorrect operation.



This symbol reminds users do not touch the screen with hands directly.



Do not place the equipment near fireplaces or high temperature objects such as gas stoves, barbecue or heaters;



Keep children and pet away from the product.



Instructions for safe operation

- Never place the screen in an unstable location, bracket, wall, to prevent the product from falling, causing serious equipment damage and personal injury.
- Do not place this product upright as it may tip over and cause damage.
- Make sure the product protected from rain and moisture.
- Do not immerse or expose this product to water or other liquids.
- Do not place this product in the following environments:
 - Poor ventilation or narrow spaces.
 - Extremely hot, cold or humid environment.
- Do not place flammable objects near this product to avoid fire.

Packing Contact

When opening the box, check the contents of the box the list below. If there is any omission, please contact the dealer in time.



Screen material



Inner frame (2 long, 2 short)



Outer frame (2 long, 2 short)



Inner corner brackets
(4 pieces)

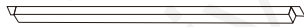

Support rods



M5 screws



M8 self-tapping screws



Outer corner brackets
(4 pieces)



M6 self-tapping screws



Spring hook (1 piece) /
Tension springs (several).



Hanging clips (2 pieces)



Suction cups (2 pieces)



White gloves



User manual+Envelopes

⚠ Notice:

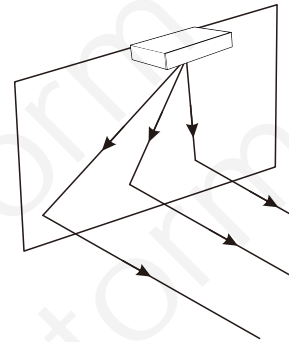
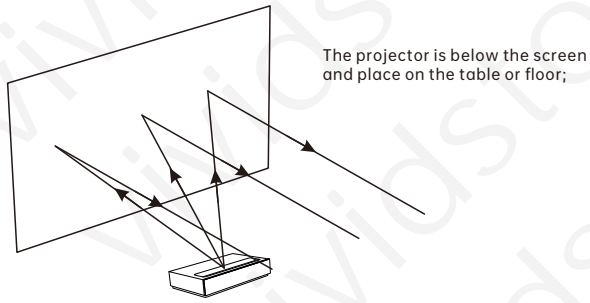

- Parking contact will be different for different countries (regions), Please refer to the actual item.
- Please keep the original packaging for future shipments.
- In special cases, the be taken out before transported. (Please contact the seller to inquire about the situation)

Because the installation method of ultra-short throw laser projector (laser TV) is divided into hoisting or placing on the desktop, the special anti-light direction structure of the screen material surface will be changed due to the installation method of the projector;



Rotate the screen material, Because the screen material itself has a sawtooth structure, it is divided into two structures; the upper slope is to resist and absorb the light, and the lower slope fully reflects the projector light; so we need to rotate the screen material so that the wiper can perfectly match the light of the projector, (the screen surface is resistant to light in the area below the screen, not against the ceiling light);

Matters Needing Attention

-  Warning! If you do not strictly follow the prescribed precautions during use, this may lead to equipment damage and other unnecessary damage.
-  Please observe the family fire safety regulations; do not place the equipment near the fireplace or high temperature objects such as gas stove, barbecue or heater to avoid equipment damage.
-  Please keep this product out of the reach of children.

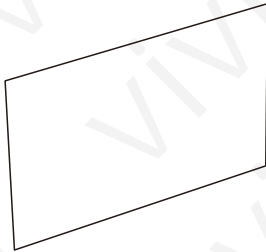

Do not place the equipment near the fireplace or high temperature objects such as gas stove, barbecue or heater



Keep children away from the product

Screen and projector compatibility

Please note that the screen of this product is only suitable for use with Ultra short throw laser projector. If it is used with other projector, the effect of picture will be greatly reduced.

It is suggested that the ultra short focus laser projector throw ratio should be ≤ 0.4 . (please consult the projection manufacturer for specific parameters)

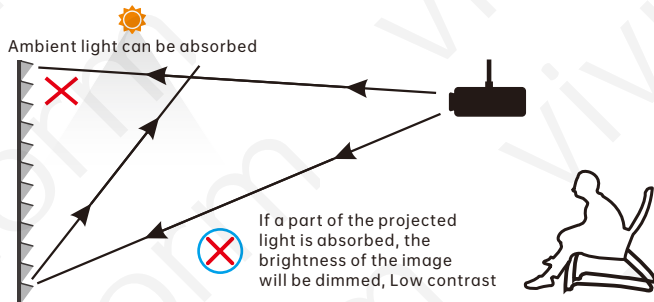
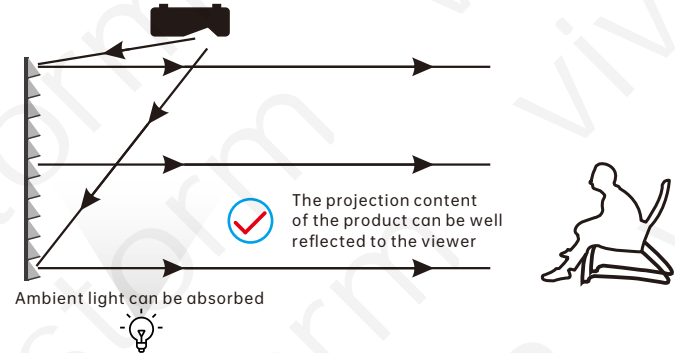
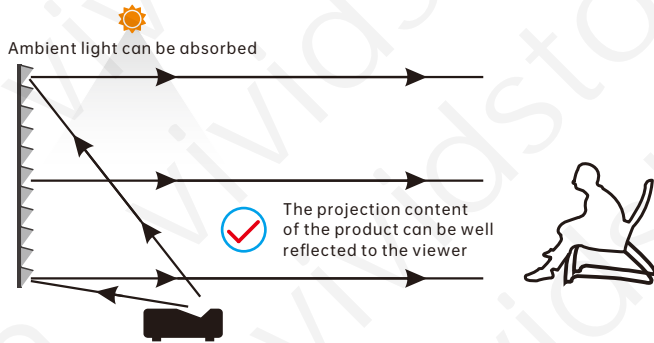

In view of the particularity of the screen structure of the product, projectors other than ultra short focus laser projectors are not compatible with this Screen fabric. If other projectors are used, the projection light may be absorbed or blocked by the Screen fabric.

3. When there are a few black spots, white spots, stains and other impurities on the screen surface, but if they are qualified according to the detection method, then such situation is not a product quality problem, and it is within the scope of product qualification.

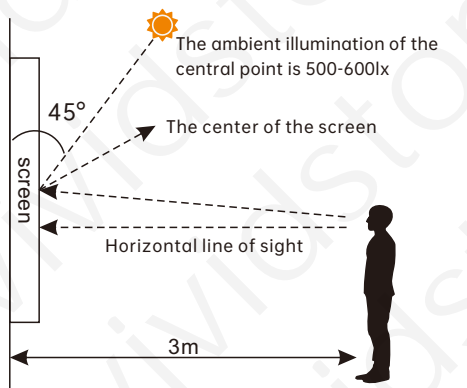

Figure 1 side view

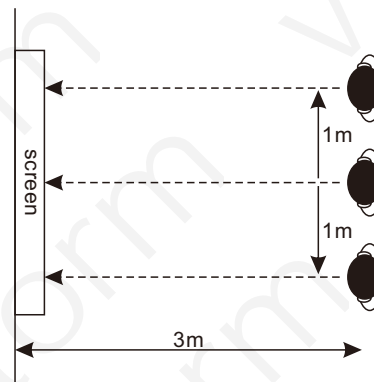

Figure 2 top view

The detection method is as follows:

- (1). Please open the screen of this product and close to the wall, and the observer can observe the film at a distance of 3 meters away from the screen;
- (2). The observer needs to observe the shadow in the normal light environment (illumination 500-600lx);
- (3). The distance between the observer and the front of the screen should be kept at a distance of 3 meters, and the center point of the screen should be close to or higher than the horizontal line of sight (as shown in Figure 1), and the observation should be made at the center point, 1 m to the left and 1 m to the right (as shown in Fig. 2).

Summary the test results of the product are within the allowable range, the product is qualified.



For the black spot defect which can be measured in appearance, if it can not be found by visual inspection, the product is normal.



For the appearance of specific measurable white spot defects, if visual inspection can not be found, then the product is normal.



If the visible dirt is within the allowable range of defects, the product is normal.



For the faint linear printing trace, if within the allowable range of defects, the product is normal.



For the inks caused by uneven printing traces, if within the allowable range of defects, the product is normal.

4. (1).The white screen is listed as the quality standard because it is not only the reflection surface of the projector image (the black surface is observed from the upper and lower direction, and the white surface is observed from the bottom direction), but also the main function surface of the viewing image, so the white screen is listed as the quality standard. It should be noted that if the white screen surface does not exceed the quality specification, it will be regarded as meeting the factory qualification standard.

(2).Different from the white screen, the black screen is used as a functional surface to absorb indoor ambient light. In view of the fact that there is no direct correlation between the black screen surface and the image viewing quality, its quality specifications are quite different from that of the white surface. It should be noted that the slight black marks on the black screen surface are inevitable appearance phenomena in the production process of industrial products, which meet the factory qualification standard.

Conclusion: it should be noted that the slight black marks and white spots on the black screen surface of the anti light projection screen products are normal product appearance phenomena, which will never affect the image viewing quality. Please use it at ease.

Operation Guide

1. Precautions:

In order to ensure the projection effect and quality of this product, please comply with the following operating requirements:

- (1). Please find a suitable size ground or platform during installation, and ensure that there are no obstacles on the surface. Clean pads such as cloth, film, blankets and the like must be placed on the pad to prevent damage to the screen and frame.
- (2). Do not rub or collide with the surface of the screen and frame with hard and sharp objects.
- (3). Do not scribble on the screen. The screen is an optical product, and any damage cannot be repaired.
- (4). Do not let children touch the screen to prevent accidents or damage to the screen.
- (5). When cleaning the surface of the screen, please use a soft and clean cotton cloth or brush to wipe it gently.
- (6). Please pay attention to daily use and cleaning care.
- (7). The screen has a front and back side. The side with a sticker labeled "Back" is the reverse side, while the other side is the front, or the projection surface.
- (8). When installing the inner and outer frames, please try to keep the joints of the frames as precise as possible.

2. After the product is installed, you can choose a suitable place to hang it.

3. It is recommended that the height of the lower margin of the picture frame screen be between 0.6-0.7 meters from the ground.

Installation Steps

1. The overall installation of the

screen **Note:** During the installation process, handle it with care to avoid scratches and drop damage.

Step 1

Clear a sufficiently spacious and clean area, and spread out the screen material as shown in the following figure. Ensure the non-woven fabric pad is at the bottom, with the back of the screen material facing upwards. During this process, be especially careful not to scratch the screen surface. (The side of the screen material with a sticker labeled "Back" is the back side.)

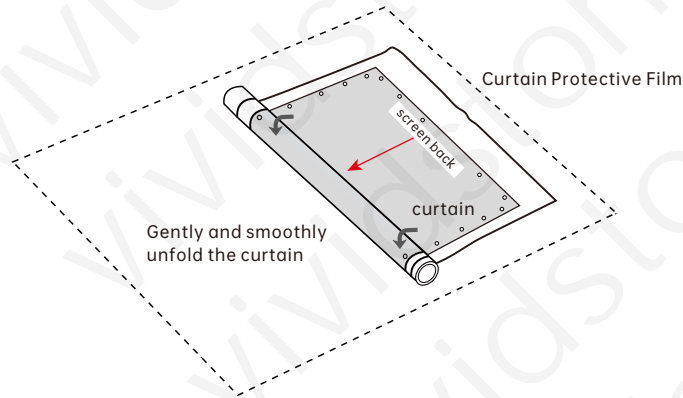

Step 2

As shown in the figure, place the inner frame, support rods, inner frame corner brackets, M5 screws, etc., on the spread-out screen material according to the positions indicated.

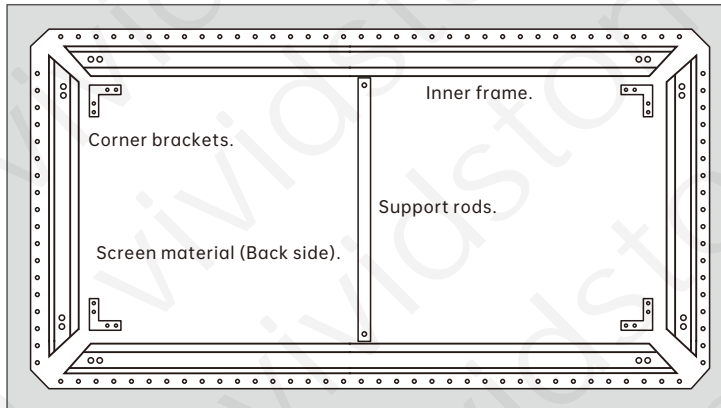

Step 3

As shown in the figure, place the inner frame, support rods, inner frame corner brackets, M5 screws, etc., on the spread-out screen material according to the indicated positions.

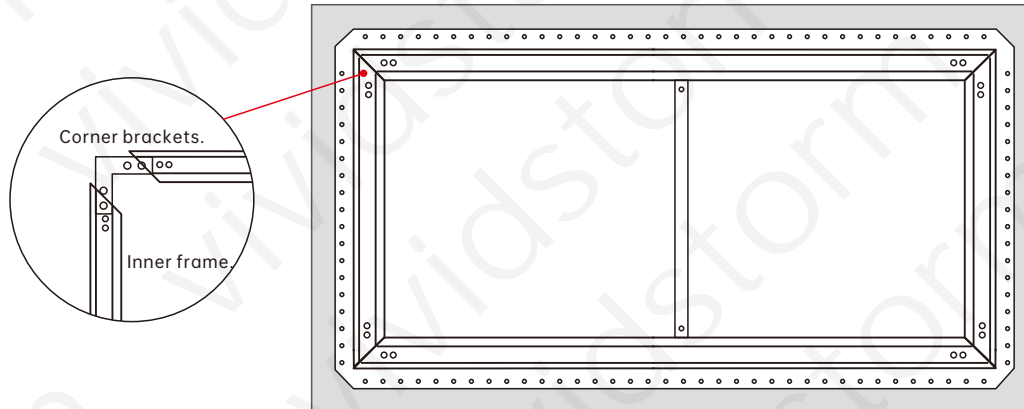

Step 4

As shown in the circled area of the figure below, roll the screen material over and hook one end of the tension springs into the grommets at the edge of the screen, and the other end into the lower groove of the inner frame. First, secure the springs at the four corners, then evenly pull the rest of the springs until all are attached. If wrinkles appear at any corner of the screen, you can adjust by adding or removing springs to smooth it out.

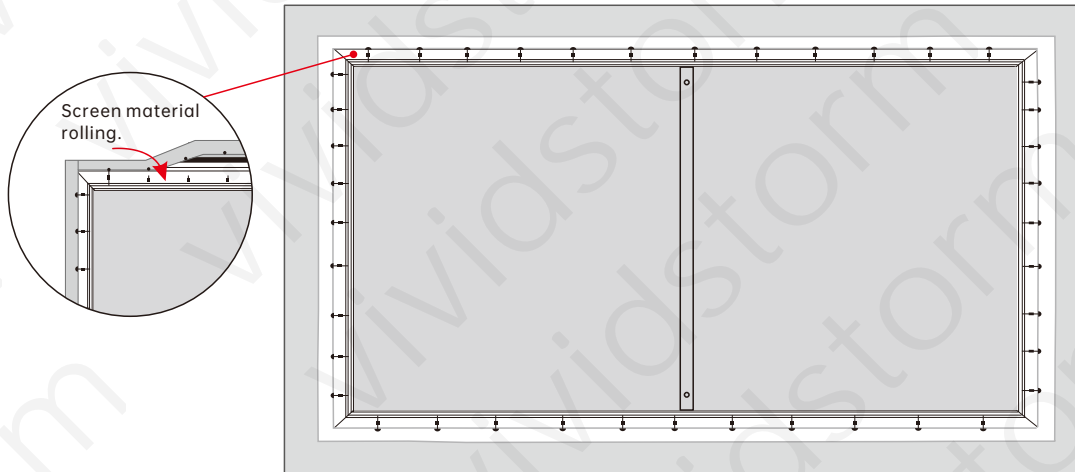

Step 5

Install the outer frame as shown, placing the outer frame, corner brackets, screws, etc., in their respective positions.

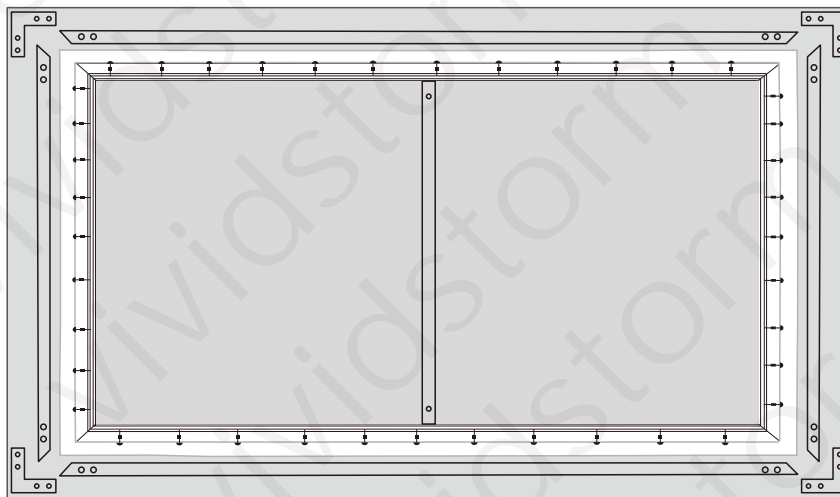

Step 6

As shown in the figure, the outer frame encloses the inner frame, and the four corners are secured with corner brackets and M5 screws. Adjust the outer frame to minimize the gaps. There will be some small holes in the middle position of the outer frame; use tension springs at these positions to pull the inner frame so that the outer frame can tightly fit against the inner frame, as shown in the figure.

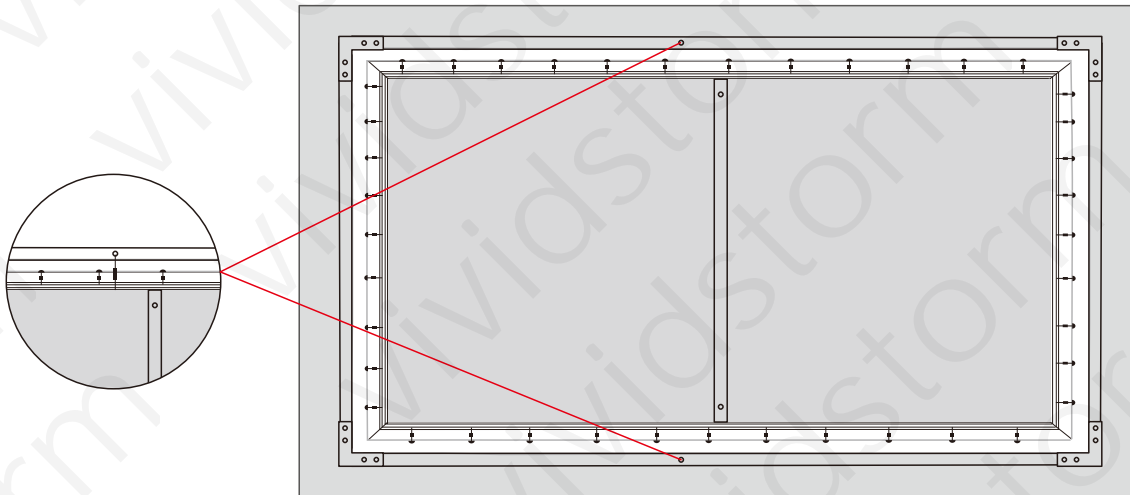

Step 7

After assembly, stand the screen up as shown in the figure below, and check if there are any wrinkles on the screen surface. Smooth out any wrinkles by adding or removing tension springs. When moving and placing the screen, please keep it in the standing position as shown in the figure.

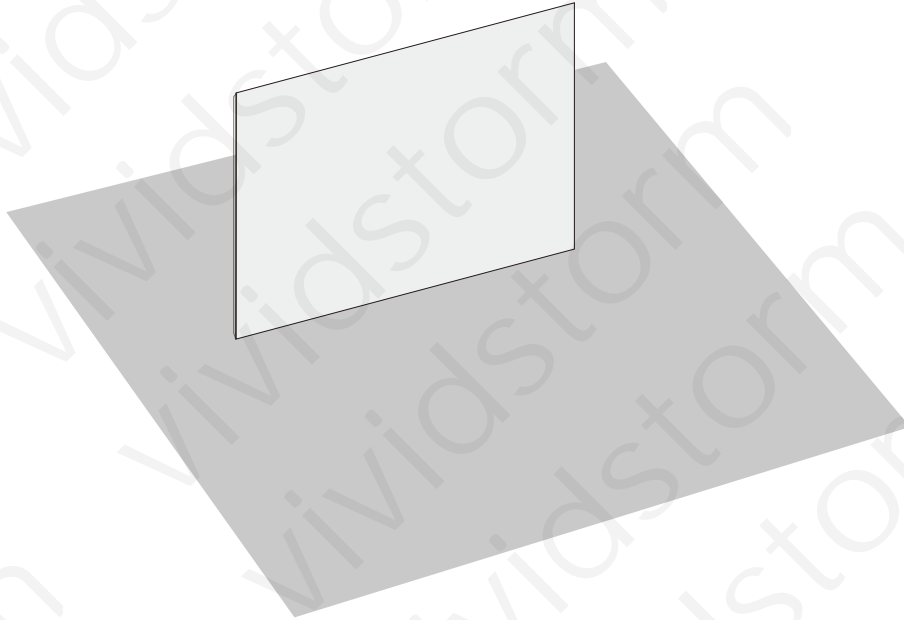

2. Installation steps on the wall

1. Determine the position of the screen based on the position of the projector. Refer to the specific parameters of each projector for height and lateral position, etc.
2. As shown, determine the height and position for the screen installation on the wall as needed. You can use a pen to outline the position of the outer frame, as indicated by the dashed lines in the figure.

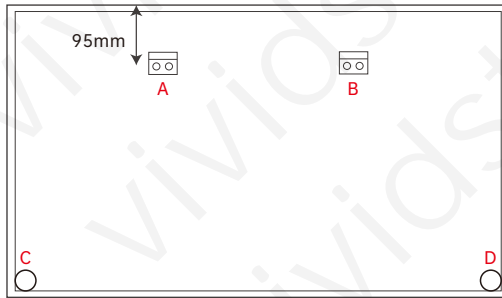
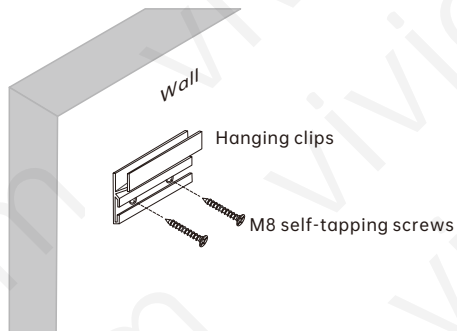

Figure 1.

Hanging clip position: The distance from the top edge of the front projection screen to the round hole of the hanging clip is 95mm.

3. In Figure 1, A and B represent the hanging clips. The distance from the installation holes of the hanging clips to the predetermined upper edge of the screen position is 95mm. They are fixed to the wall with M8 self-tapping screws.



4. Step One (Figure One): Suction cups C and D are optional components, to be installed only in cases where the bottom corners of the screen are lifted due to uneven walls. Installation method is as follows: Fix suction cups to the corresponding locations at the bottom corners of the screen with M6 self-tapping screws on the wall, ensuring the suction cups grasp the corner brackets of the screen frame.

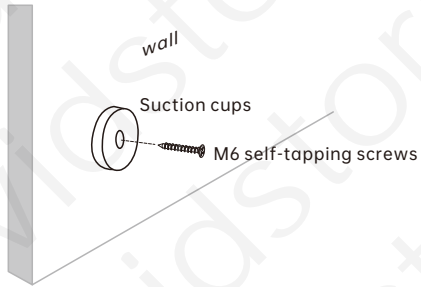

5. Mount the screen, adjust left and right, installation complete.

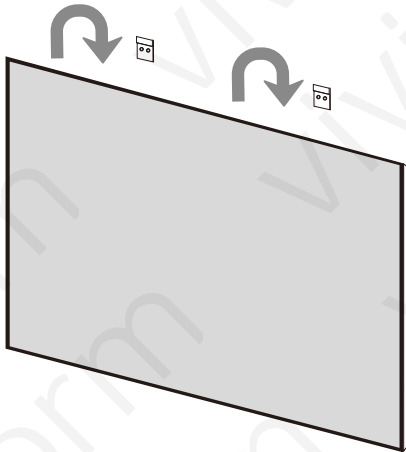

Screen Maintenance

Cleaning requirements:

1. In general, please use a soft brush to clean the screen surface. Remember to use a special soft brush and gently brush away the impurities along the screen grain direction.
2. Do not use any cloth (coarse cloth, soft cloth, gauze, wet cloth) to wipe the screen surface.
3. Rough towel or cloth may damage the screen surface and affect the viewing effect.
4. There is a horizontal structure on the screen surface, so please brush away the impurities along the left and right direction of the grain when cleaning the screen; do not wipe it up and down or round the screen.
5. The backside surface of the curtain can be wiped with cloth, but it should be ensured that the screen is dry before closing the screen, because the surface of the curtain is not waterproof.
6. Due to the weather, especially the humidity; The screen surface may be wrinkled, it is a normal situation; it can return to normal under normal temperature, and can be relieved by heating with a hair dryer.

Warning!

- Do not scribble on the screen.
- Do not touch the screen directly by hand.
- Do not touch the screen with hard or sharp objects.
- Do not clean the screen persistently or vigorously, so as to avoid screen scratch.
- Be sure to turn off the screen when you are not using the product.
- This product is not waterproof, only suitable for indoor use, not recommended for outdoor use.
- Avoid sharp objects directly contacting the screen surface, so as to avoid puncturing or scratching the screen surface.
- Do not run the screen up and down for more than 3 minutes, otherwise the screen will stop running. This is the phenomenon of motor overheating protection shutdown. Please wait 20-30 minutes for the motor to cool down before continuing operation.
- To avoid possible injury, do not attempt to remove the screen. If there are obvious damaged parts, please contact your authorized dealer.

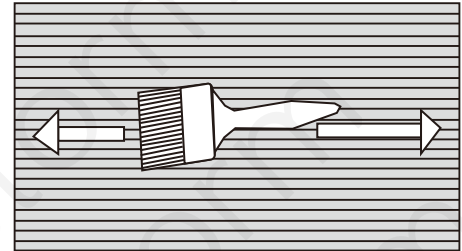

Manufacturer's Warranty

Thank you for choosing VIVIDSTORM screens for your home or business. We are committed to providing high-quality products that meet your expectations. To ensure your satisfaction and peace of mind, we offer the following warranty policy for VIVIDSTORM screens:

1. **Warranty Coverage:** VIVIDSTORM screens are covered by a limited warranty against defects in materials and workmanship. This warranty applies to the original purchaser of the screen and is non-transferable.
2. **Warranty Period:** The warranty period for VIVIDSTORM screens is 2 Years from the date of purchase.
3. **Warranty Services:** If during the warranty period the VIVIDSTORM screen is found to have a defect covered by the warranty, VIVIDSTORM will, at its discretion, either repair or replace the defective screen or its components. VIVIDSTORM will cover the cost of parts and labor required to perform the repairs.
4. **Exclusions:**
 - The warranty does not cover damage or defects resulting from:
 - Improper installation, misuse, or abuse of the screen
 - Failure to follow the installation and operation instructions provided by VIVIDSTORM
 - Accident, fire, flood, or other external causes
 - Unauthorized modifications or repairs
 - Normal wear and tear
5. **Warranty Claim Procedure:** To initiate a warranty claim, the purchaser must notify VIVIDSTORM by contacting our customer service department at [Insert Contact Information]. A VIVIDSTORM representative will guide you through the claim process, including providing any necessary documentation or evidence of the defect.
6. **Proof of Purchase:** To be eligible for warranty services, the purchaser must provide a valid proof of purchase, such as a sales receipt or order confirmation, demonstrating the date of purchase.
7. **Shipping Costs:** If a warranty claim is approved, VIVIDSTORM will cover the cost of shipping the repaired or replaced screen back to the customer. However, the customer is responsible for the cost of shipping the screen to VIVIDSTORM for warranty service.

8. Limitation of Liability: VIVIDSTORM'S liability under this warranty is limited to the repair or replacement of the defective screen or its components as stated above. VIVIDSTORM shall not be liable for any indirect, consequential, or incidental damages arising from the use or inability to use the screen.

Other branded products or merchandise sold on VIVIDSTORM websites are under warranty provided by the brand owner or distributor. VIVIDSTORM shall act on your behalf with the warranty claims.

9. Governing Law: This warranty policy shall be governed by and construed in accordance with the laws of country or region where the product is shipped to.

Please note that this warranty policy is subject to change without prior notice. The warranty provided herein is in addition to any rights you may have under applicable consumer protection laws.

If you have any questions or need further clarification regarding the warranty policy, please do not hesitate to contact our customer service department.

Thank you for choosing VIVIDSTORM screens. We appreciate your trust in our products.

Certificate

Product Name: _____ Product Model No: _____
Factory serial No: _____ Inspector: _____
Date of production: _____

The product has been tested and inspected after operation, and all the tests and inspections have been in accordance with the technical requirements, and its quality meets the specified requirements. Only after passing the inspection can they be allowed to leave the factory.

Product Warranty Card

User information

Customer retention sheet

Customer name: _____ Customer telephone: _____
Postcode: _____ Customer's address: _____
E-Mail: _____ Purchasing channels: _____

Purchase date: _____ Date of production: _____
Invoice number: _____ Warranty content: _____
Customer signature: _____ After sale: _____
Date: _____

Satisfied Dissatisfied

Manufacturer: HUI ZHOU VIVIDSTORM FILM AND TELEVISION EQUIPMENT CO., LTD.

Add: NO.66 Zhongxing North Rd , Aotou Town, Daya Bay, Huizhou City, Guangdong Province, China

Website: <http://www.vividstormscreen.com> Email Us: support@vividstormscreen.com Call Us: 0086-752-3096010



For Your Dream Picture