

# Electric Slimline Tab-tension Screen

## USER MANUAL



# Content

To Users -----	2	Screen Running -----	20
Safety Instructions -----	2	Manual Switch -----	21
Packing Contact-----	4	Remote control -----	23
The Introduction Of Product-----	5	Screen Height Limit Setting -----	26
Appearance -----	5	Black border up (adjust shorter the fixed height of the screen) ----	26
Certificate-----	8	Black border down (adjust longer the fixed height of the screen) -	28
Important Safety Precautions -----	9	Screen Maintenance -----	30
Matters Needing Attention -----	10	Manufacturer's Warranty -----	31
Matters Concerning Projection -----	13	Certificate -----	33
Projected Area -----	13	Product Warranty Card -----	33
About Screen Performance -----	14		
Installation Warning -----	15		
Before pre installation -----	15		
Hardware Parts List -----	15		
Suspended installation -----	16		
Wall / ceiling installation-----	18		

## To Users

Thank you for choosing the VIVIDSTORM projection screen.

Please read this manual carefully before using the product and keep it properly.

The manual of products, accessories, user interface, etc. in this description are schematic diagrams and are for reference only. Due to product updates, the actual product may be slightly different from the schematic diagram, please refer to the actual product.

## Safety Instructions

For your security and interest, to ensure safe and correct use of this product, always comply with the following precautions to avoid dangerous situations and damage to your unit:

### Safety Instructions



This symbol warns the user that uninsulated voltages within the body of this product may be sufficient to cause an electric shock, therefore, any form of contact with any part within the body is a risk of electric shock.



This symbol reminds the user to some important information related to operation and maintenance.  
Please read this information carefully to avoid incorrect operation.



Earth Terminal Ground Symbol  
This refers to using this product needs electrical grounding.



Shipping Instructions  
Please use this product's original packaging or same materials to transport this product.



This symbol reminds users not to throw sundries into the housing inside to avoid mechanical damage to the screen.



This symbol reminds the user to stay away from the inside of the housing, especially during operation.



Keep children and pet away from the product.



Do not place the equipment near fireplaces or high temperature objects such as gas stoves, barbecue or heaters;



This symbol reminds the user prevent hands or other body parts from entering the inside of the bracket, causing hand pinching;



All items that are not product parts should be kept away from moving parts.



To prevent electric shock, fire hazard.

- Using incorrect cables may affect product performance, and may even lead to electric shock, fire and other accidents. In order to ensure product performance and safety, please use the same type of cable as the original cable.
- If a power extension cord is required, use a power cord with an amperage rating not lower than that of the product. Otherwise, it may cause the power cord to overheat, and even cause electric shock, fire and other accidents.
- In thunderstorm weather or when the product is not used for a long time, please unplug the power plug from the socket to avoid damage to the device caused by lightning or power line surges.
- Do not place flammable objects near this product to avoid fire.



Instructions for safe operation

- Never place the screen in an unstable location, bracket, wall, or ceiling, to prevent the product from falling, causing serious equipment damage and personal injury.
- Do not attempt to disassemble this product, there are dangerous high voltages inside that could cause personal injury. When repair is required, it must be done by trained or authorized service personnel.
- Do not place this product upright as it may tip over and cause damage.
- Make sure the product protected from rain and moisture.
- Do not immerse or expose this product to water or other liquids. If any liquid or solid object enters the cabinet, please unplug the power cord of the device immediately and ask professional service technicians to check it before continuing to use it.
- Do not place this product in the following environments:
  - Poor ventilation or narrow spaces. ● Near any device that generates a strong magnetic field. ● Direct sunlight.
  - Extremely hot, cold or humid environment.

# Packing Contact

When opening the box, check the contents of the box the list below. If there is any omission, please contact the dealer in time.



Projection screen



User manual+Envelopes

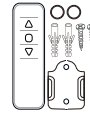

(IR)Infrared remote control (includes wall mount accessory)

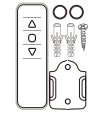

RF wireless remote (includes wall mount accessory)

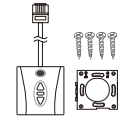

wired remote control with IR sensor (with the wall bracket, wall screws included)



Lifting ring



Wall / ceiling mounting bracket (with mini "L" type screw driver, includes wall mount accessory)



Adjust Rod (soft and hard)

NO.	Accessories Name	Quantity (pcs)
1	Projection screen	1
2	User manual+Envelopes	1
3	(IR)Infrared remote control (Contains 2 button cell battery) (includes wall mount accessory)	1
4	RF wireless remote (Contains 2 button cell battery) (includes wall mount accessory)	1
5	wired remote control with IR sensor (with the wall bracket, wall screws included)	1
6	Lifting ring	2
7	Wall / ceiling mounting bracket (with mini "L" type screw driver, includes wall mount accessory)	2
8	Adjust Rod(soft and hard)	2

## ! Notice:

- Parking contact will be different for different countries (regions), Please refer to the actual item.
- Please keep the original packaging for future shipments.
- Gifts are not covered under warranty.
- In special cases, the battery will be taken out before transported. (Please contact the seller to inquire about the situation)

# The Introduction Of Product

## Appearance

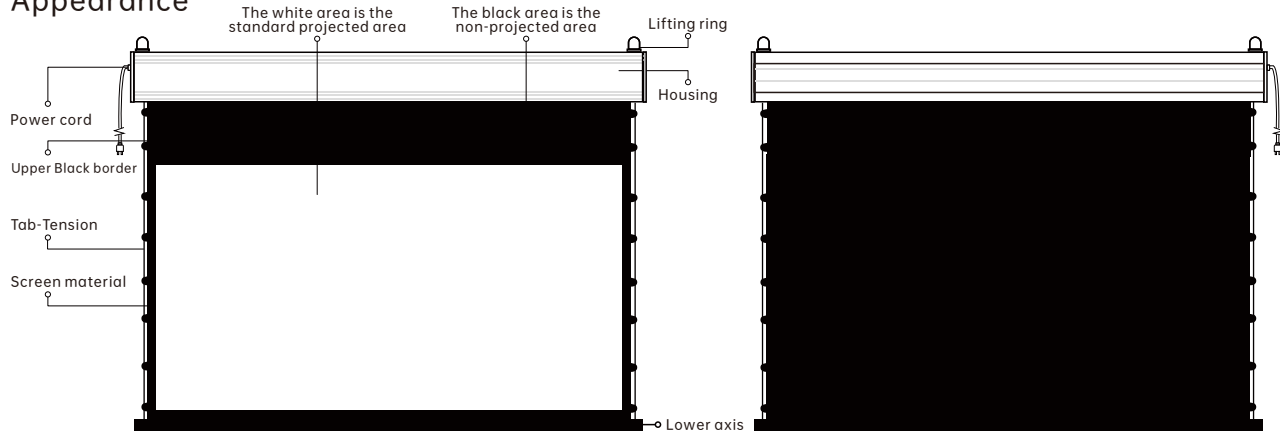

(Screen open - front view)

(Screen open- rear view)

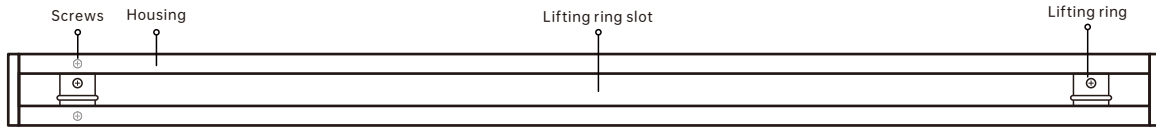

(Screen close- top view)



(Screen close - bottom image)

# Appearance

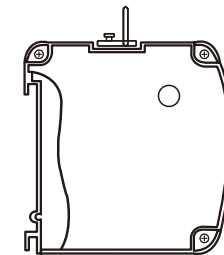
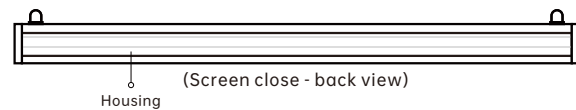
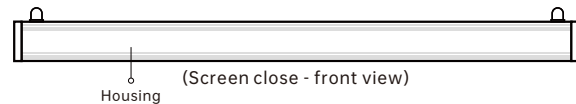
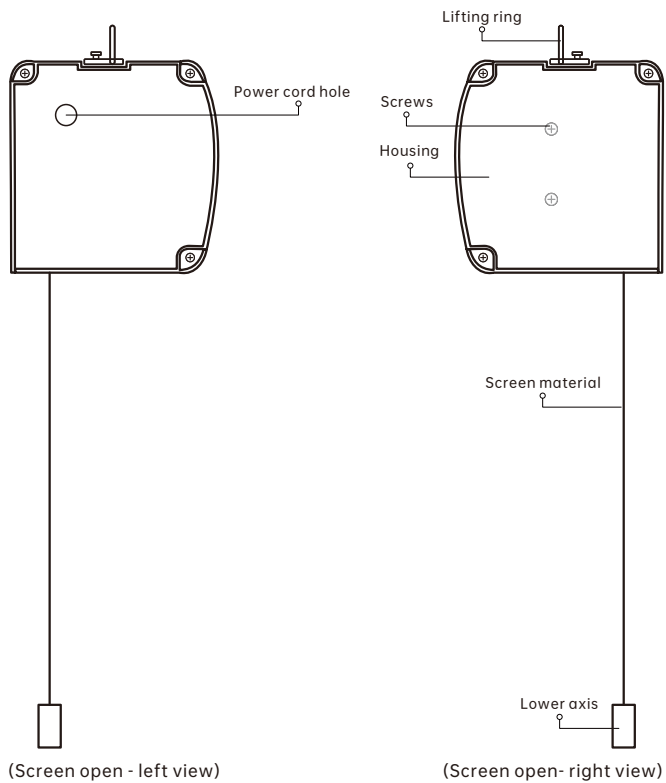

(After the screen is closed - internal anatomy left view)

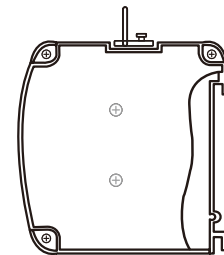

(After the screen is closed - internal anatomical view from the right)

# Appearance

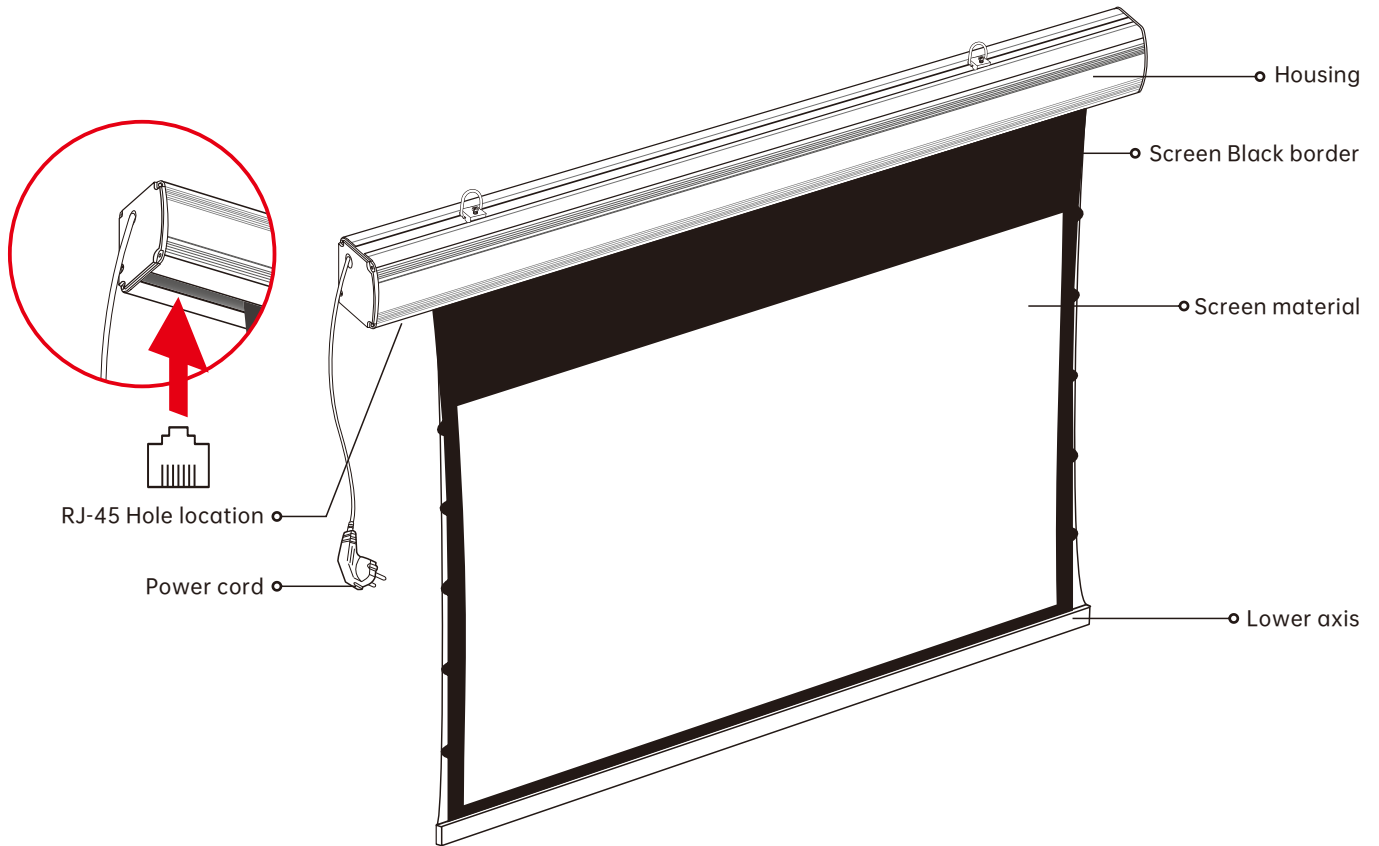



## Pilot lamp

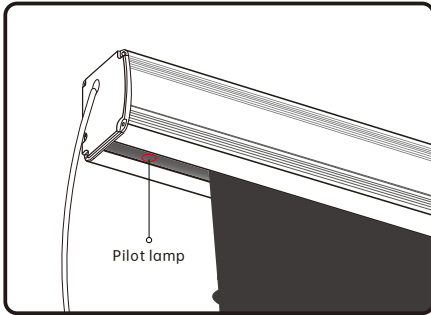

(Picture 1)

### Power lamp, make the following prompts for the working status:

- Picture 1, when the red light of the power light is on and there is a beep~, it means it is working normally. If the red light flashes and doesn't light up, it is abnormal, please contact after-sales support.

## Certificate



**RoHS**



\*The right to interpret the above certification belongs to our company

# Important Safety Precautions

**Please read all the contents of the user guide carefully and follow the operation steps below.**

For reference when necessary, please keep this user guide.

1. In order to avoid damage to the equipment, please prohibit the use of any accessories not authorized by the manufacturer.
2. Be sure to handle the products carefully during transportation, so as to prevent product damage caused by collision.
3. In order to ensure the personal safety of the user and realize the reliable operation of the equipment, please make sure to use the power cord provided by the equipment to connect the power supply for charging.
4. Please place the device close to the power socket to connect the power supply for charging.
5. You need to place the product properly. Please do not place any heavy objects on the power cord and screen to avoid danger or operation obstacles.
6. In order to avoid electric shock, short circuit or fire caused by loose plug, please use the power cord correctly.
7. Since this product is equipped with a V-spring support system with strong tension, removing the screen without permission will bring certain risks. Please do not disassemble the screen by yourself. In case of machine failure caused by your improper operation, the seller and the manufacturer have the right not to be responsible for replace the product. In case of personal injury, no liability shall be assumed.
8. **The tubular motor on the electric screen of this product has a temperature control sensor with overheating protection mechanism. If the screen runs up and down continuously for One and a half minutes, the motor will rest for more than 30 minutes.in order to prevent the motor from overheating and damage,If the motor stops operation due to the start of overheat protection mechanism, please turn off the power and wait for 30 minutes to 2 hours until the motor cools down.**
9. The remote control supplied with this product contains coin / button cell battery. If the coin / button cell battery is swallowed, it can cause severe internal burns in just 2 hours and can lead to death. Keep new and used batteries away from children. If the battery compartment does not close securely, stop using the product and keep it away from children. If you think batteries might have been swallowed or placed inside any part of the body, seek immediate medical attention.

## Matters Needing Attention

- ⚠ Warning! If you do not strictly follow the prescribed precautions during use, this may lead to equipment damage and other unnecessary damage.
- ⚠ Please observe the family fire safety regulations; do not place the equipment near the fireplace or high temperature objects such as gas stove, barbecue or heater to avoid equipment damage.
- ⚠ Please keep this product out of the reach of children.

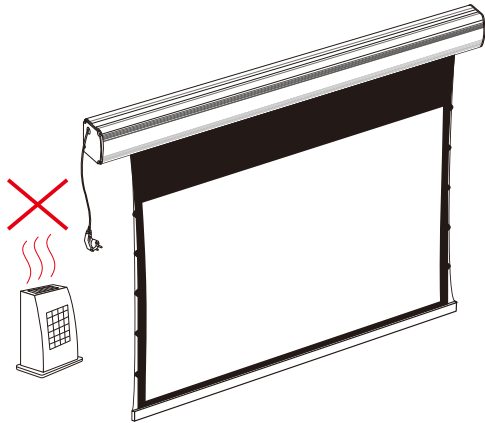

Do not place the equipment near the fireplace or high temperature objects such as gas stove, barbecue or heater



Keep children away from the product

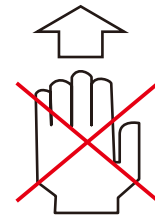

Do not put your hands into the cover of the product

## Matters Needing Attention

No one is allowed to open the inside of the equipment and repair the product without authorization, except for the authorized technicians.

1. Please make sure that the power supply connected to this product has stable current.
2. If you need to use the extension cord for this product, please make sure that the power cord rating of the extension cord is the same as that of this product, so as to avoid equipment damage due to overheating.
3. When your hands and feet are in contact with water, do not operate the power plug in this case.
4. When you encounter heavy rain, wind, thunder or lightning in the process of using this product, please be sure to disconnect the power line.
5. The curtain of this product should not be placed in direct sunlight, rain and humid environment.
6. In order to prevent the product from overheating, keep away from fire source and high temperature equipment when using this product. At the same time, the power supply of this product should be cut off before transportation or maintenance.
7. Like any other household appliances, when this product is not used for a long time, please completely disconnect the power supply to ensure safety.
8. If there is any obvious damage to any parts of the product, in order to avoid any injury and electric shock, please do not continue to use.
9. When installing in the residential and commercial buildings, users should provide reasonable protection for the products to prevent the radiated RF energy from interfering with the operation of the products. However, there is no guarantee that the product will not be disturbed in special installation.

**Note: fixed parts to prevent screen swing are installed in the equipment cover. Please remove them before use and keep them properly for standby.**

- (1) There are two fixed parts in the housing to prevent the screen from swinging from side to side. Please unscrew the small screws at the back of the housing and remove the fixed parts.

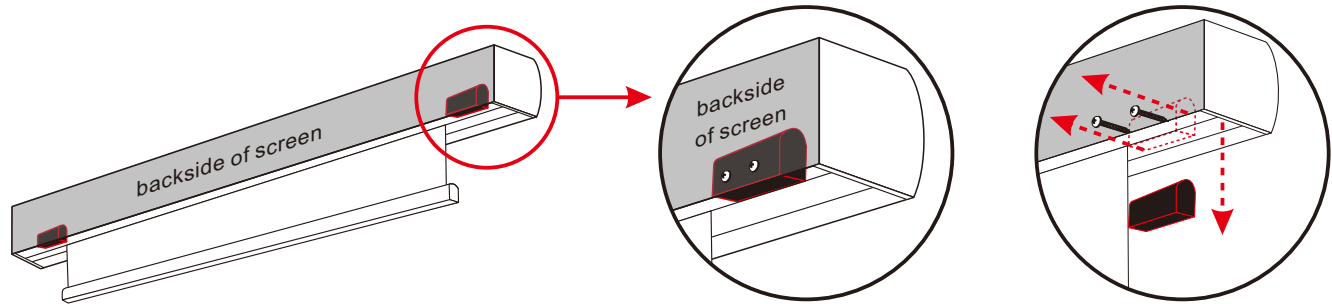

- (2) The lower shaft is equipped with several fixed parts to prevent the screen from swinging back and forth. Please slide and remove the aluminum alloy fixing parts.

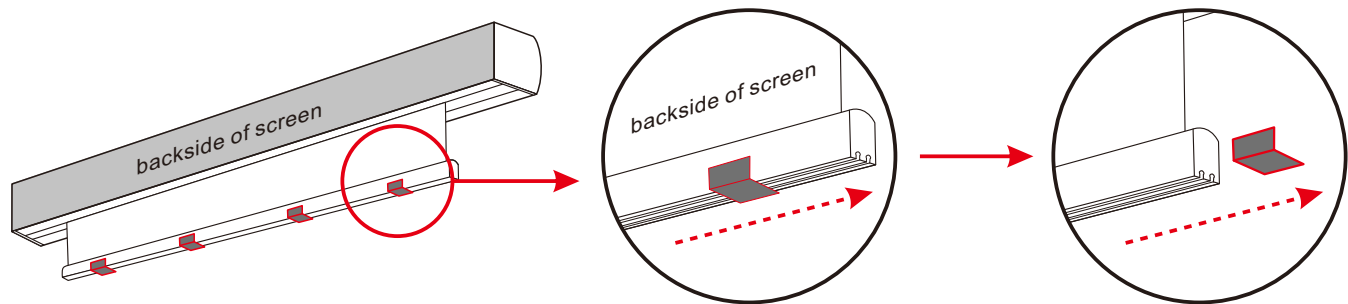

# Matters Concerning Projection

## Projected Area

1. Please project according to the actual projection size of the screen purchased when using the projector.
2. Since the position of black border has been preset on the screen of this product, please do not exceed the specified projected area during projection. You should note that the default black border is not the projection area.

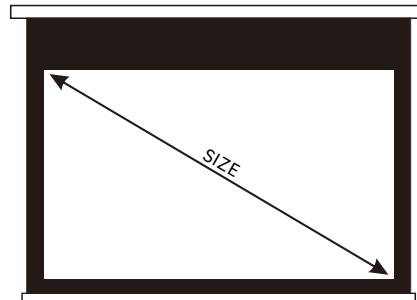

Classic product design:  
Screen with black border

### Notice:

The screen has been set to the lowest position when leaving the factory, no height can be adjusted.

## About Screen Performance

1. The screen is only suitable for normal throw projectors.
2. If there are regular creases on the screen surface after the screen is opened, don't worry. This is a normal phenomenon. It is caused by the screen being curled and tightened for a long time, which does not affect the user's viewing. After opening the screen for a period of time, you will notice that the stripes on the screen will gradually disappear.

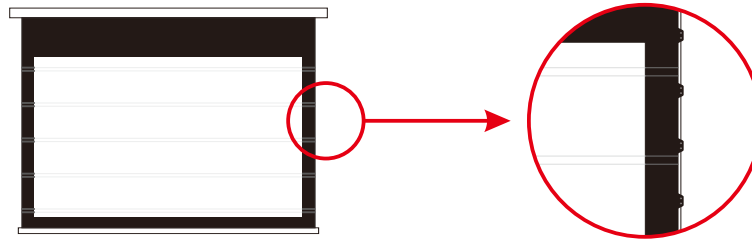

# Installation Warning

Since the installation environment of each user is different, the instructions in this user guide are only for reference. If you need further installation and safety suggestions, please consult the professional installation company. It should be noted that no matter what kind of installation method you take, the product should not be loosened or dropped due to vibration or tension, so as to keep the product stable. The installation personnel of the product must ensure that the bracket accessories used have sufficient strength to support the product and select the appropriate installation position.

## Before pre installation

1. When you open the package, please carefully open the screen package to avoid the product from rubbing or falling.
2. Please always place the screen in a horizontal position. Do not install the product on an uneven or inclined surface.
3. Please keep the screen away from dust, sawdust and liquid to protect the screen from contamination.

## Hardware Parts List

Before you install the product, make sure that all parts of the product are included. Please note that the screws supplied with this product may not be suitable for all mounting surfaces. Please consult the professional installation personnel or hardware store to get the correct installation screws and anchors.



Hollow Wall Anchor



Small screws

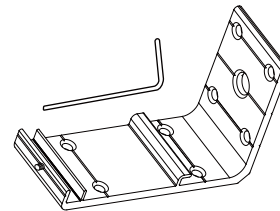

Wall / ceiling mounting bracket  
(with mini "L" type screw driver)



# Suspended installation

1. The lifting ring of the equipment has been installed into the slide rail and fixed when leaving the factory.
2. To adjust the position of the lifting ring, loosen the screw on the ring slightly.
3. After adjusting the position of the lifting ring, please tighten the screw, and then hang the equipment on the fixed wall hook.

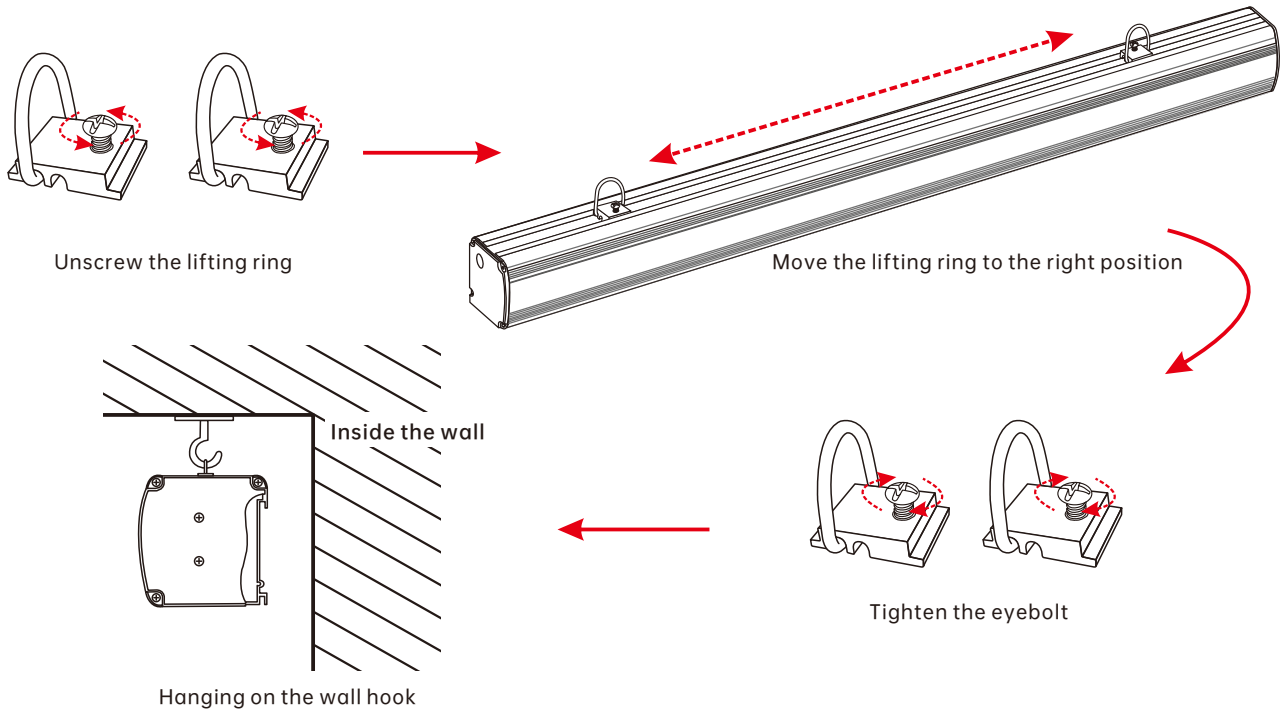

## Note:

- The fixed distance of the two hanger should be left and right in the middle of the cover, not too close to the middle or side;
- The screen hanging from the ceiling should be flat.

Put the hanger on the hook. For high ceiling installation, chain or steel cable can be used (additional hanging parts need to be purchased)

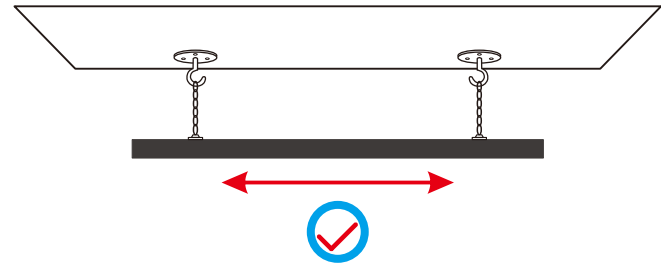
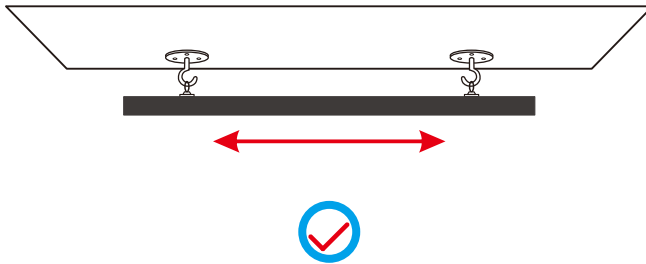

Note: please make sure the equipment is installed horizontally and do not tilt it.

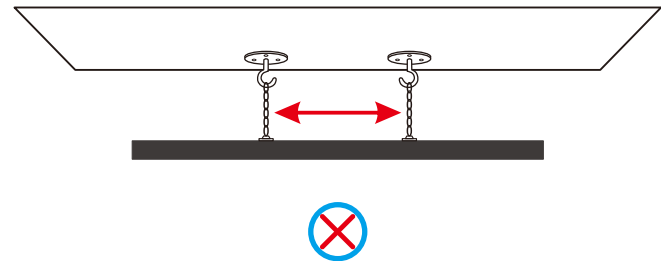
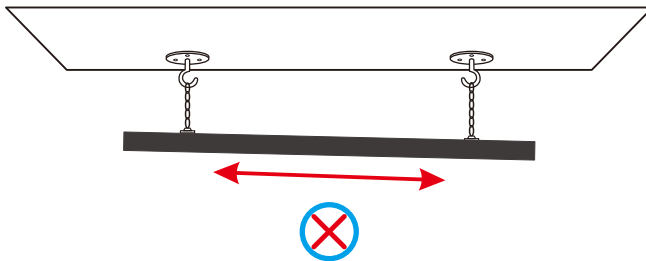

# Wall / ceiling installation

1. Determine the installation position of the equipment, measure and mark the distance between the top and bottom screw holes of each bracket, and whether the distance between the two hanger is appropriate, and ensure that they are on the same horizontal line.
2. Then, drill a hole of suitable size at all marked points and install the bracket on the wall with screws.

More than two people are required to complete the following steps

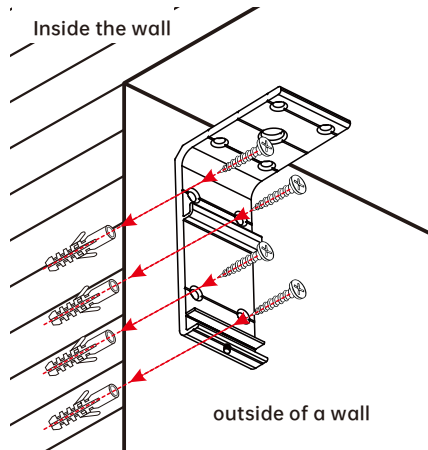

Wall installation

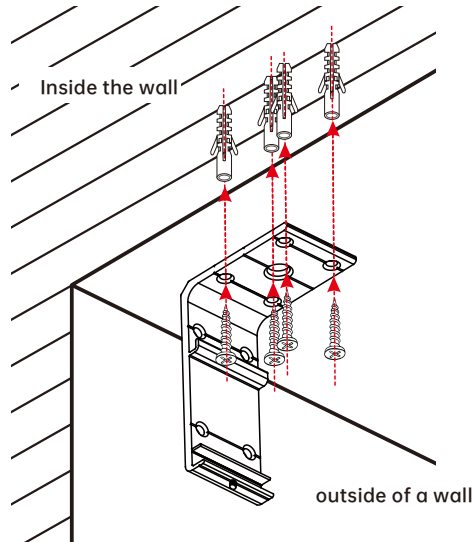

Ceiling installation

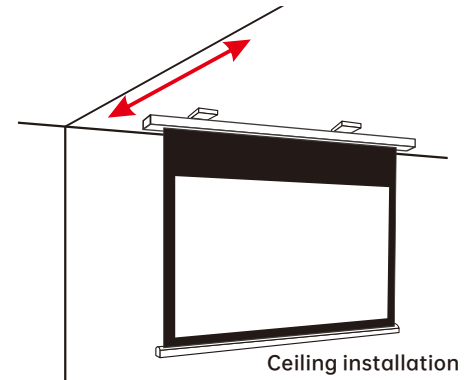
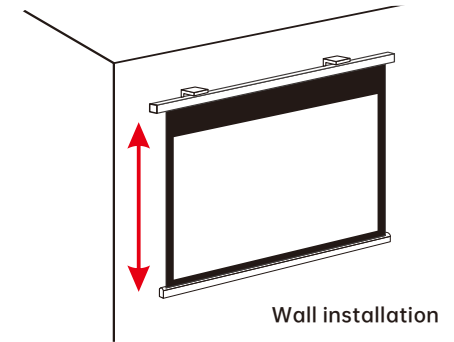

3. Lift the screen upward to make it level with the bracket, clip the screen into the bracket slot and push it until a "click" sound is heard to ensure that the screen is firm.

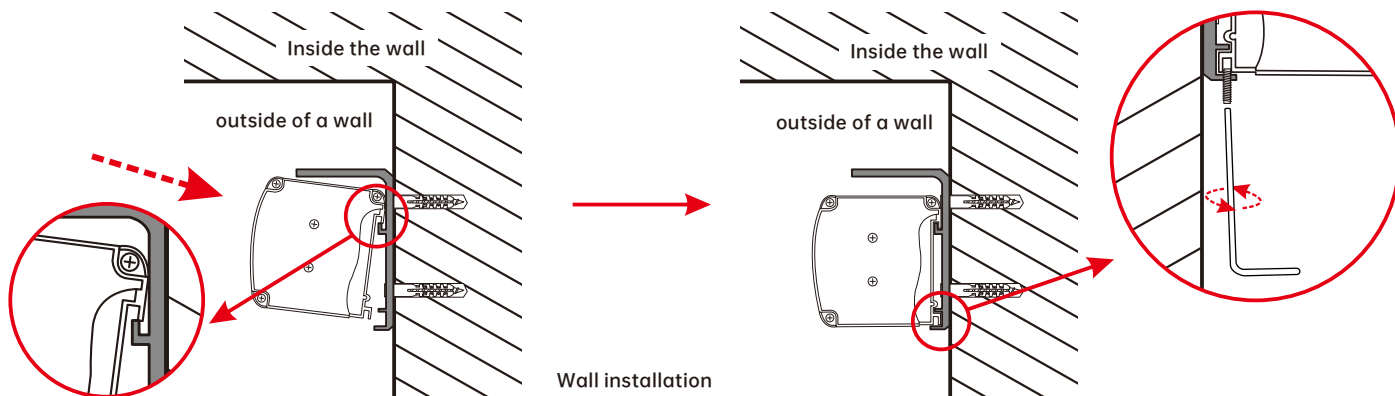

4. After the equipment is stuck in the bracket, please use the mini "L" type screw driver to tighten the screw to fix the housing and the bracket.

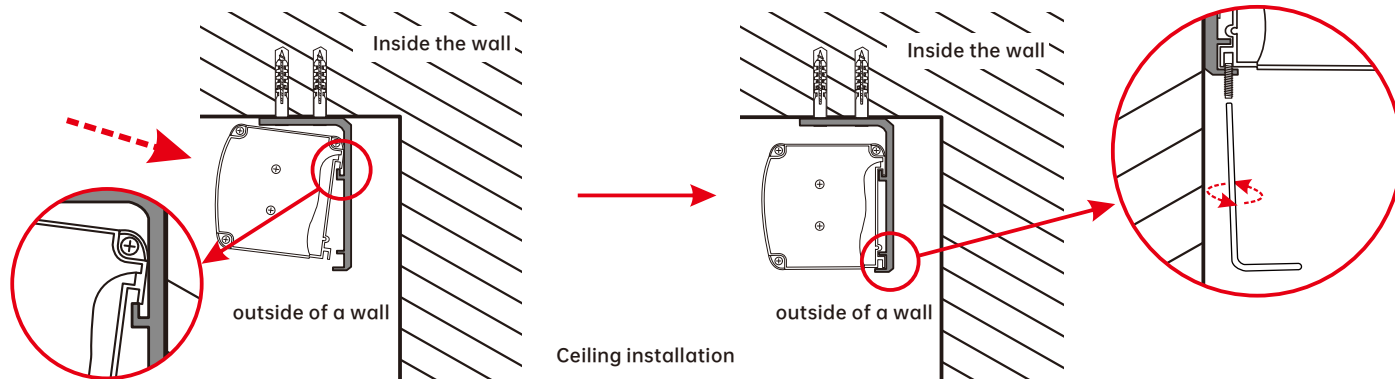

# Screen Running

Voltage information: make sure your screen is working at the **correct voltage**, depending on the area.

**(Using the wrong voltage may cause the screen to become inoperable)**

- (1) Plug the screen power cord into the correct power outlet.
- (2) When the product power is turned on, a "beep" sound will be emitted for 1.5 seconds, indicating that the product has been powered on.
- (3) When the screen is fully raised, you can choose to turn off the power switch and unplug the power cord due to long-term viewing. At this time, the screen will remain open and will not be closed due to power off. To turn off the screen, connect the power cord and turn on the switch to resume operation.
- (4) When the left power switch is powered on, you can use any of the methods described below to run the screen.

**Note: When the screen is turned on, ensure that there is no obstacle and enough space at the bottom of the screen to avoid equipment failure.**

# 1.Manual Switch

The wired wall switch is a wall-type remote control with "up/stop/down" buttons, directly plugged into the RJ-45 input interface of the screen to use.

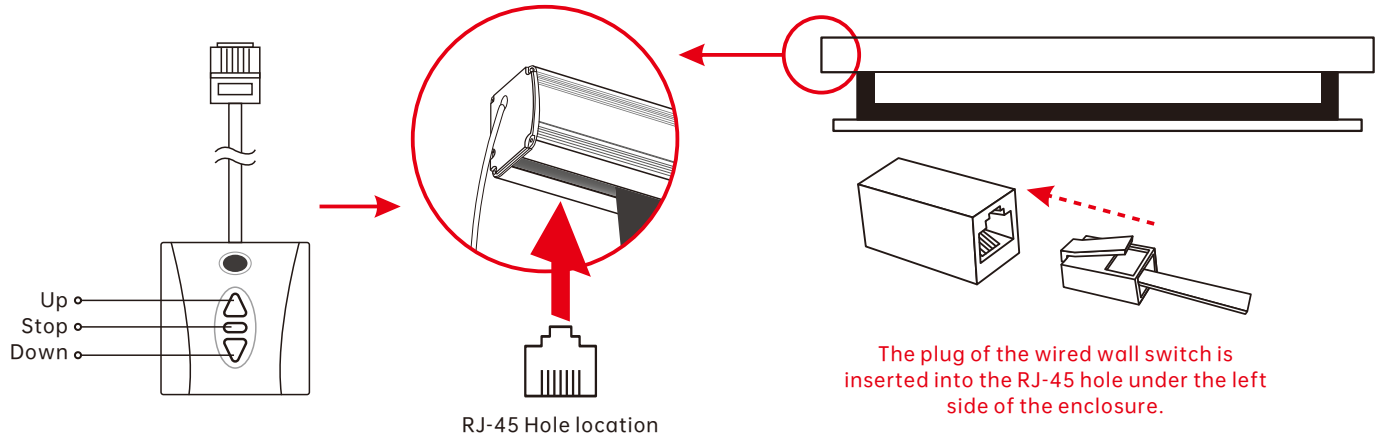

- If necessary, the wall switch with infrared receiver head can be installed on the wall;
- First, find the appropriate position on the wall and drill holes, then fix the fixed bracket on the wall, and finally fix the wired wall switch on the bracket, and connect the RJ-45 connector;
- In addition to fixing the switch bracket with wall screws, try to fix the switch bracket with double-sided adhesive tape. (bracket can be found on the back of the switch)

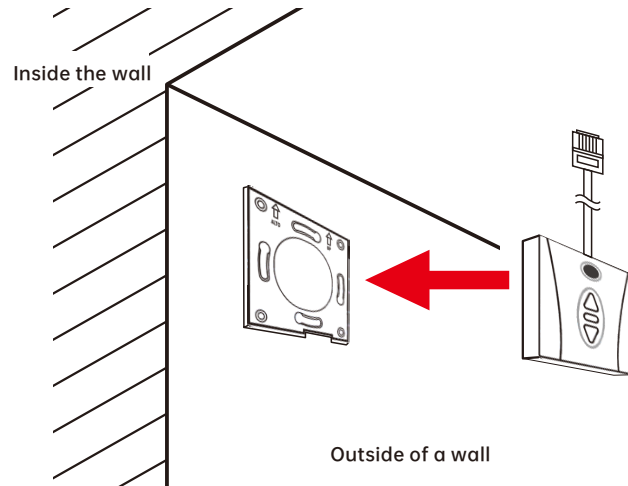
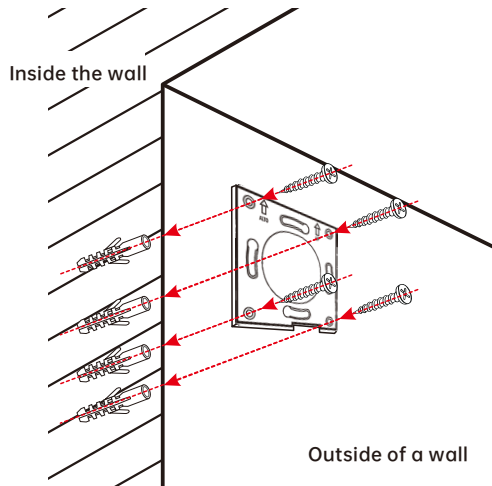

## 2.Remote control——RF remote control / IR remote control

- (1) Wireless RF remote control: when the screen is hidden and installed in the slot or requires remote control, wireless remote control can be used. It can control the screen without aiming at the IR receiver.
- (2) IR remote control needs to be connected with the IR receiver. When using IR remote control, make sure that the power switch is turned on and aligned with the IR receiver head, so that the IR remote control can operate normally.

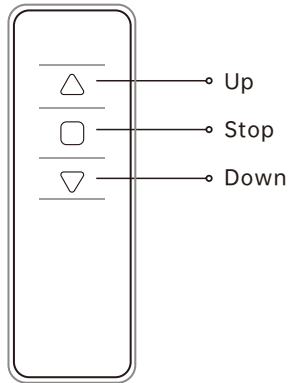

Front of remote control

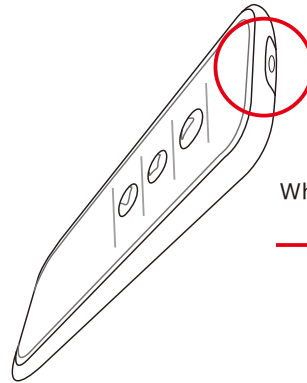

Perspective view of infrared remote control

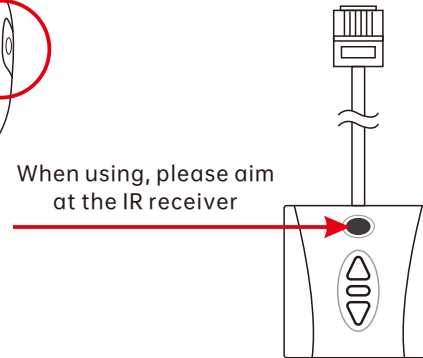

Infrared receiver switch



For convenient access, the remote controller can be fixed on the wall surface and other planes through the bracket. (wall screw or double-sided adhesive tape can be used for fixation)

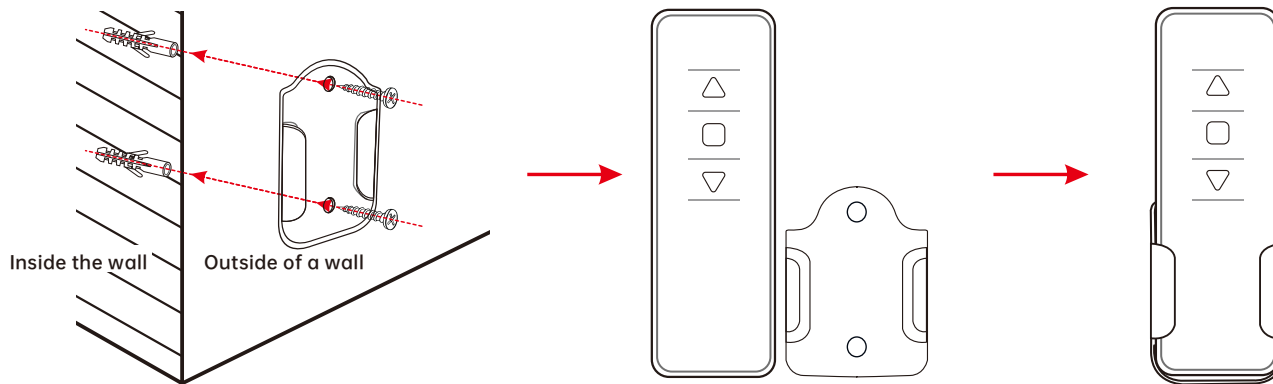

When the remote control needs charging, as shown in the figure below, unscrew the cover of the remote control with a small screw, then replace the new button battery, close the cover of the remote control, and tighten the screw to prevent the loose battery from falling off;

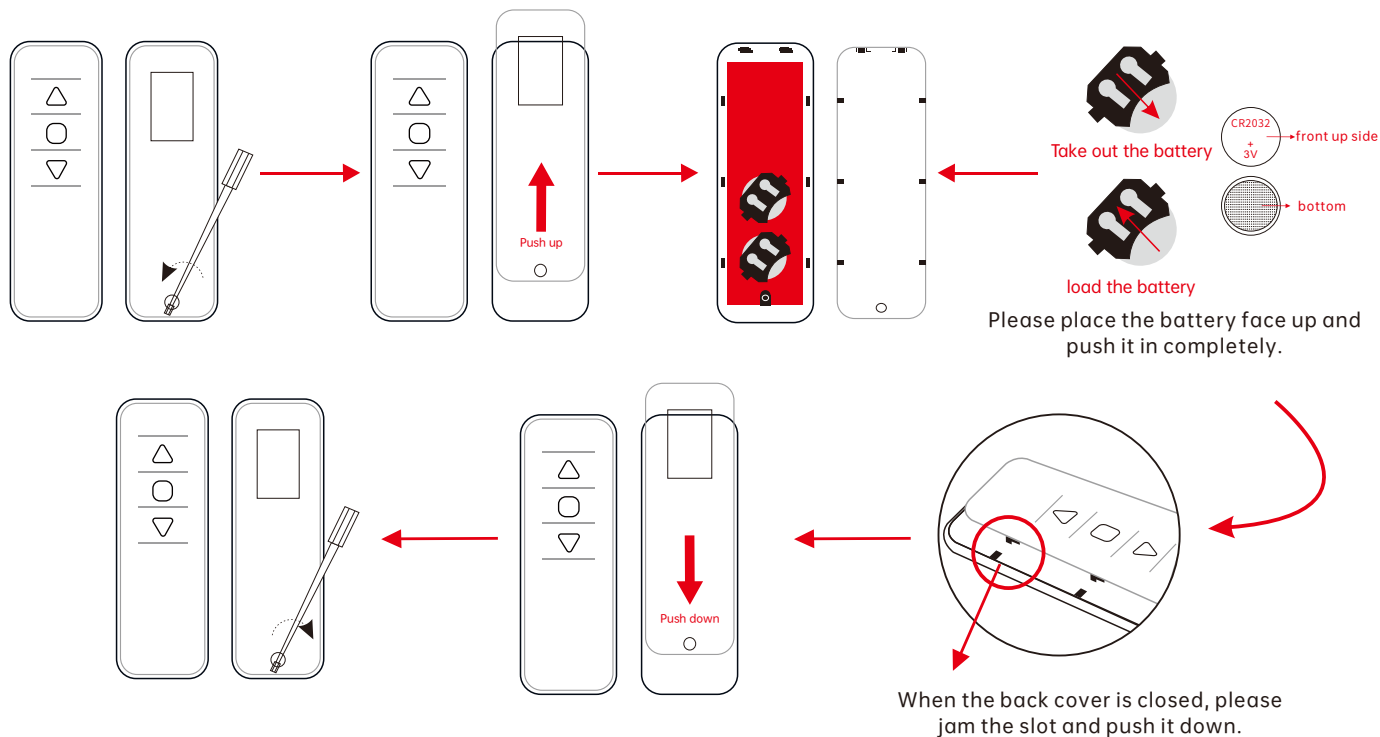

## Screen hight limit setting

**Black border up** (adjust shorter the fixed height of the screen)

**(The longest position of the screen has been set at the factory, no longer height can be adjusted)**

If the screen is too low, follow the steps below to fix the screen to the desired position.

1. Please make sure the product is powered on.
2. As shown in the figure, stand at the bottom of the screen, look inside the housing, and find the white adjusting hole under the motor with the help of a light source.
3. Insert the debugging rod into the white adjusting hole in the housing, and then slowly rotate it clockwise for several turns **(rotate one circle and adjust the screen height by about 2cm)**. After each rotation, press the "up" switch, and then press the "down" switch. The screen up to the appropriate position, and finally the screen will stop at a shorter position than the factory setting. Please check whether the length is appropriate.

**If you can't find the hole location, You can stand at the bottom of the screen with the help of a light source to find the hole position.**

If the screen height is still very long, please repeat the above operation to adjust it to the appropriate position.

**(Please refer to the picture )**

1

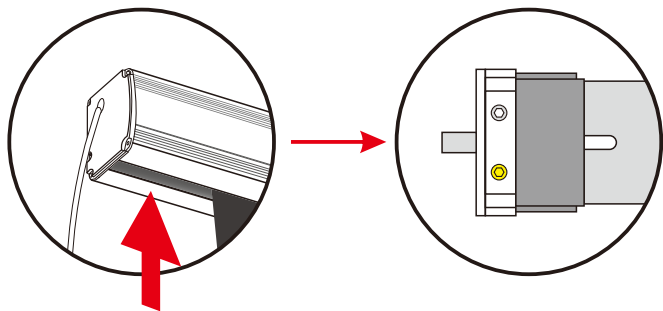

Stand at the bottom of the screen with the help of light source to find the hole position.

2

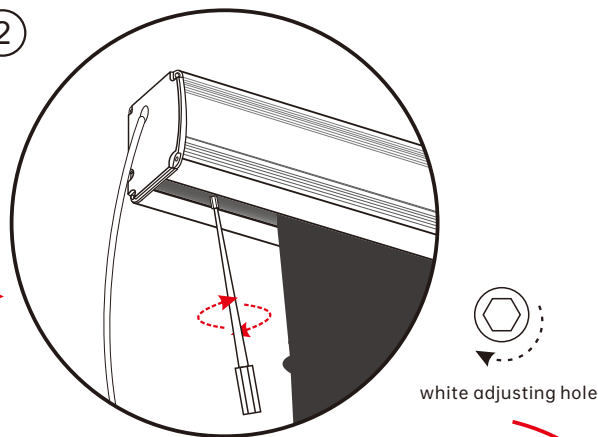

Insert the adjust rod into the white adjusting hole in the housing, and then slowly rotate it clockwise for several turns  
**(rotate one circle and adjust the screen height about 2cm)**

4

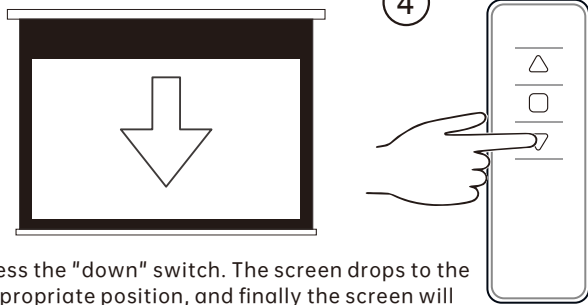

Press the "down" switch. The screen drops to the appropriate position, and finally the screen will stop at a higher position than the factory setting.

3

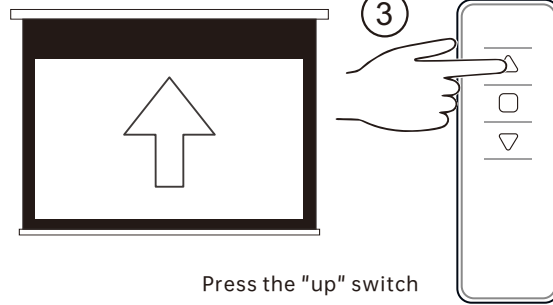

Press the "up" switch

## Black border down(adjust longer the fixed height of the screen)

If adjustment the black border of the screen is too short, please follow the following steps:

(please note: it is not allowed to carry out this step directly without adjusting the screen to be short in previous step)

(1) Please press the "Down" button on the remote control, and the screen will drop to the lowest point.

(2) Insert the adjusting rod into the motor adjusting hole on the lower left side of the housing, and then rotate it several times in an anti-clockwise direction(**rotate one circle and adjust the screen height about 2cm**). Then press the "Down" key, the screen will drop to the adjusted height and stop operation. Please pay attention to control the height, do not exceed the original lowest point, do not rotate too much, otherwise the screen will reverse and cause screen damage.

(Please refer to the picture )

If the adjustment is too long, please repeat the previous steps to adjust to the appropriate position.

### Notice:

-The screen has been set to the longest position when leaving the factory, no lower height can be adjusted.

-Do not adjust too long or too short at one time. We suggest that you adjust the screen a slowly.

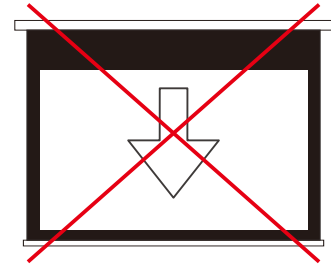

1

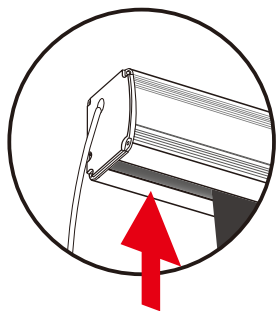

Stand at the bottom of the screen with the help of light source to find the hole position

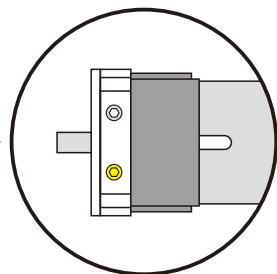

2

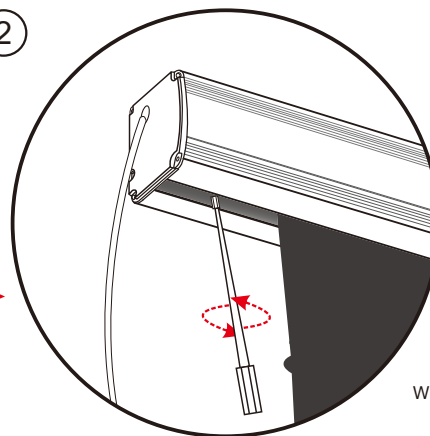

White adjusting hole

Insert the adjust rod into the white adjusting hole of the shell, and then rotate it slowly for several turns anti-clockwise  
 (rotate one circle to adjust the screen height about 2cm)



3

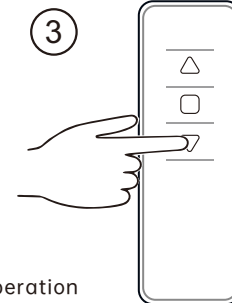
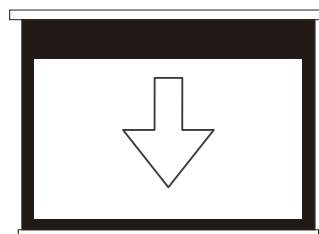

Press the "down" switch, and stop the operation by lowering the screen to the lowest height

# Screen Maintenance

## Cleaning requirements:

1. It can be cleaned with soft water;
2. Please use a clean cotton cloth or soft dust brush to remove dust particles on the screen;
3. Due to the weather, especially the humidity; The screen surface may be wrinkled, it is a normal situation; it can return to normal under normal temperature, and can be relieved by heating with a hair dryer.

## Warning!

- Do not scribble on the screen.
- Do not touch the screen directly by hand.
- Do not touch the screen with hard or sharp objects.
- Do not clean the screen persistently or vigorously, so as to avoid screen scratch.
- Be sure to turn off the screen when you are not using the product.
- This product is not waterproof, only suitable for indoor use, not recommended for outdoor use.
- Avoid sharp objects directly contacting the screen surface, so as to avoid puncturing or scratching the screen surface.
- Do not use acetone, benzene, alcohol and other organic solvents to clean the screen, which will cause permanent damage to the screen.
- Do not run the screen up and down for more than 3 minutes, otherwise the screen will stop running. This is the phenomenon of motor overheating protection shutdown. Please wait 20-30 minutes for the motor to cool down before continuing operation.
- To avoid possible injury, do not attempt to remove the screen. If there are obvious damaged parts, please contact your authorized dealer.

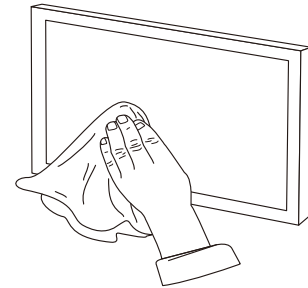

# Manufacturer's Warranty

1. VIVIDSTORM products have 2-year warranty. During the warranty period, in case of any problems caused by the product itself or the product defects caused by the design, Please contact the after-sales service to inform the situation. During the warranty period, if the product fails to work normally due to user negligence (not product material or design defects, etc.), not eligible for a warranty, for serious damage to the product should charge that fee according to the product damage. After the warranty period expires, all repairs or replacements are charged the fee, and users will get a quote for the repair fee. Only after the user agrees and accepts the maintenance cost can the maintenance service be started.
2. Within one week after the user receives the product, if there are obvious serious defects in the product, the user shall provide video or photo proof, and provide the corresponding certificate and warranty card to our after-sales service personnel. After confirmation, the user can return the product and reship a new product. The user needs to ensure that the returned product is in good condition kept in its original status., free from any physical damage, and that the packaging is complete. We will handle the returned or exchanged products within 7 days (excluding public holidays).
3. The motors in all products sold by our company enjoy a five-year warranty. It is necessary to ensure that the motor is complete and has not been tampered with.
4. The company provides corresponding after-sales technical support services for the products sold and guarantees customer service response within 24 hours. (except holidays)
5. Within one week after the customer receives the product, due to the special packaging size of the product, it is recommended to save the carton in order to solve the packaging problem of return and replacement.
6. If the address provided by you (the customer) or your agent is incorrect or incomplete, the address needs to be revised, or the wrong product, size or color is selected for personal reasons, and the package is returned to us, we need to send it to the correct address , you will be charged for the shipping cost of returning the package and the additional shipping cost of sending the package.
7. It should be noted that the product damage caused by the following factors is not caused by the company, the damage caused by other human factors and natural disasters are not included in the warranty scope of the company:
  - (1). Improper installation, resulting in product damage;
  - (2). Voltage mismatch;
  - (3). Improper use caused by not operating according to the product manual;
  - (4). Product quality problems caused by installation, maintenance, alteration, disassembly, and assembly without the authorization of the company, as well as the user's own misuse, collision, scratching, etc.;
  - (5) The proper working environment is not provided;
  - (6). Product damage caused by the user's secondary transportation;
  - (7) Any products and accessories not produced by VIVIDSTORM.



- (8). The validity period of the guarantees has exceeded.
- (9). The product has no quality problems after testing, BUT it has exceeded the 7-day no-reason return period
- (10). Damage caused by force majeure;
- (11). Labels, machine serial numbers, and anti-counterfeiting signs are torn, altered, brands, warranty cards, and serial numbers are inconsistent with the product, or the product has been altered;
- (12). Damaged in natural disasters and unexpected situations, such as floods, fires, manmade, etc. The above guarantees have the same legal effect on each user. Due to changes in countries or regions, other rights may only apply to specific customers;
- (13). Other situations that should not be covered by warranty according to law. Please contact our official customer service hotline to deal with after-sales matters. If the product is damaged by services and accessories not authorized by our company, it is not a product quality problem of our company, and you will not be able to enjoy our after-sales service.

## Certificate

Product Name: \_\_\_\_\_ Product Model No: \_\_\_\_\_  
Factory serial No: \_\_\_\_\_ Inspector: \_\_\_\_\_  
Date of production: \_\_\_\_\_

The product has been tested and inspected after operation, and all the tests and inspections have been in accordance with the technical requirements, and its quality meets the specified requirements. Only after passing the inspection can they be allowed to leave the factory.

## Product Warranty Card

User information

Customer retention sheet

Customer name: \_\_\_\_\_ Customer telephone: \_\_\_\_\_  
Postcode: \_\_\_\_\_ Customer's address: \_\_\_\_\_  
E-Mail: \_\_\_\_\_ Purchasing channels: \_\_\_\_\_

Purchase date: \_\_\_\_\_ Date of production: \_\_\_\_\_  
Invoice number: \_\_\_\_\_ Warranty content: \_\_\_\_\_  
Customer signature: \_\_\_\_\_ After sale: \_\_\_\_\_  
Date: \_\_\_\_\_

Satisfied  Dissatisfied

Manufacturer: HUI ZHOU VIVIDSTORM FILM AND TELEVISION EQUIPMENT CO., LTD.

Add: NO.66 Zhongxing North Rd , Aotou Town, Daya Bay, Huizhou City, Guangdong Province, China

Website: [www.vividstormscreens.com](http://www.vividstormscreens.com)

Email Us: [vividstormscreen@gmail.com](mailto:vividstormscreen@gmail.com)

Call Us: 0086-752-3096010



**For Your Dream Picture**