

P/N: **UF-M36**

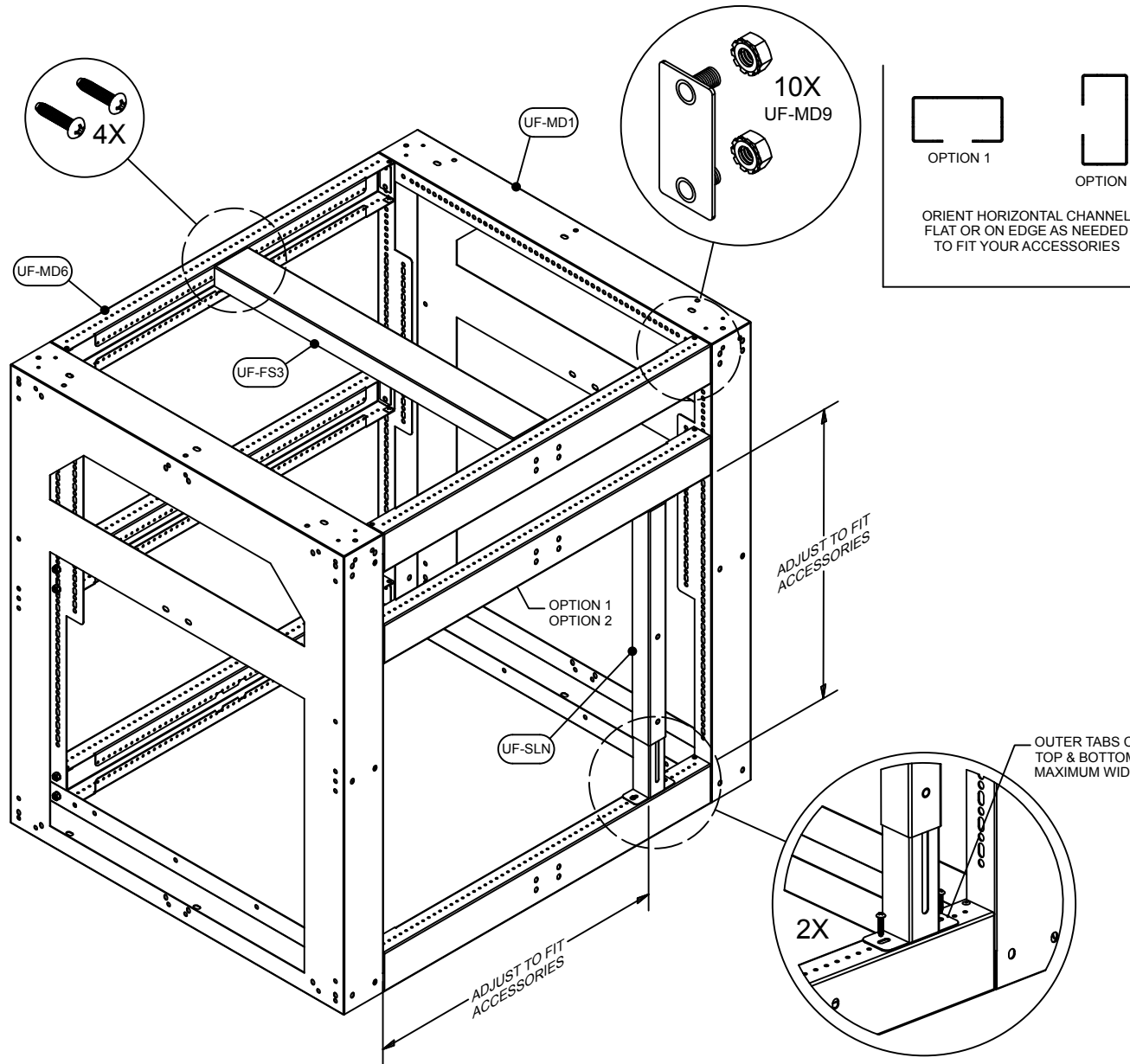

HARDWARE PROVIDED



DOUBLE STUD PLATES (UF-MD9)



1/4-20 LOCK NUTS



#8-32 X 3/4" THREAD CUTTING SCREWS

PARTS LIST		
PN	DESCRIPTION	QTY
UF-MD1	END PANEL OR SPACER	2
UF-MD6	HORIZONTAL CHANNEL, 29"	6
UF-SLN	ADJUSTABLE VERTICAL SLIDE	1
UF-MD9	DOUBLE STUD PLATE	12
UF-FS3	FLOOR SUPPORT, 26-1/2"	1

All installations must be ventilated in compliance with applicable local, state, and federal codes
All adjustments to be based on appliance manufacturer's recommendations and all local building codes

Uniframe Systems, LLC

145 Bodwell Street | Avon, MA 02322

844.883.3330 | www.uniframe.com