



Assembly Instructions

Riley **CURE** FORCED AIR

RILEY FORCED AIR CONVEYOR DRYER



Riley Hopkins

Serial Number: _____

Date: ____/____/____

(Record your machine's serial number and date of purchase for future reference)

IMPORTANT INSTRUCTIONS:

Read all these instructions before installing or using this equipment.

All wiring to this equipment must be connected to the electrical source in strict accordance with *National Electrical Code* (N.E.C.) and local codes having jurisdiction.

Do not use extension cords to power this equipment.

Before installing this equipment, the user must be aware of the safety requirements as specified by the *National Board of Fire Underwriters*.

/// CAUTION! ///

Puncture of the element face may result in a shock hazard.

This heater is hot when in use. To avoid burns, do not let bare skin touch hot surfaces. Keep combustible materials, such as furniture, pillows, bedding, papers, clothes, etc. away from the dryer.

Extreme caution is necessary when any dryer is used by or near children or invalids and whenever the heater is left operating and unattended.

Do not operate any heater after it malfunctions. Disconnect power at service panel and have heater inspected by a reputable electrician before reusing.

Do not use outdoors.

To disconnect dryer, turn off power to dryer circuit at main disconnect panel.

Do not insert or allow foreign objects to enter any ventilation opening as this may cause an electric shock or fire, or damage to the dryer.

A dryer has hot and arcing or sparking parts inside. Do not use it in areas where gasoline, paint, or flammable vapors or liquids are used or stored.

Use this dryer only as described in this manual. Any other use not recommended by the manufacturer may cause fire, electric shock, or injury to persons.

RETAIN THIS MANUAL FOR FUTURE REFERENCE

Please review all instructions prior to assembling, installing or operating the equipment. Verify the proper tools, materials, and personnel are available for the safe and successful use of the dryer.

The RileyCURE FORCED AIR DRYER may ship in a crate with some assembly required. The crate contains the Dryer Chamber with legs, the Conveyor Take-Up Assembly, the Conveyor Drive Assembly, a Conveyor Belt, & and Hardware Kit (See Fig. 1). Confirm that all are present. Contact Ryonet immediately if there is a discrepancy.



Tools Required:

- ½” wrench or socket
- ¼” hex (or Allen) key
- Phillips and flathead screwdrivers
- Needle nose pliers

A dedicated circuit disconnect is required for proper operation / protection of this dryer.

SINGLE PHASE DRYERS:

Voltage: 240/208 Volts 50/60 Hz

Single Phase Voltage	MODEL NUMBER RCA-244-X-X	MODEL NUMBER RCA-364-X-X
240V	7.2 KW / 31 A	10.9 KW / 46 A
208V	5.4 KW / 26 A	8.2 KW / 40 A

3-PHASE DRYERS:

Voltage: 240/208 Volts 50/60 Hz

Three Phase Voltage	MODEL NUMBER RCA-244-X-X	MODEL NUMBER RCA-364-X-X
240V	7.2 KW / 21 A max	10.9 KW / 33 A max
208V	5.4 KW / 18 A max	8.2 KW / 25 A max

/// WARNING ///

DO NOT plug the equipment in (or apply power) until instructed to do so.

Assure that all appropriate “**LOCK-OUT / TAG-OUT**” procedures are followed to prevent power from being distributed to the control panel before called for in these instructions.

A dedicated electrical (earth) ground is required for proper operation of the equipment.

Wiring must be compatible with existing building receptacles and local electrical codes.

Dryer Assembly Instructions:

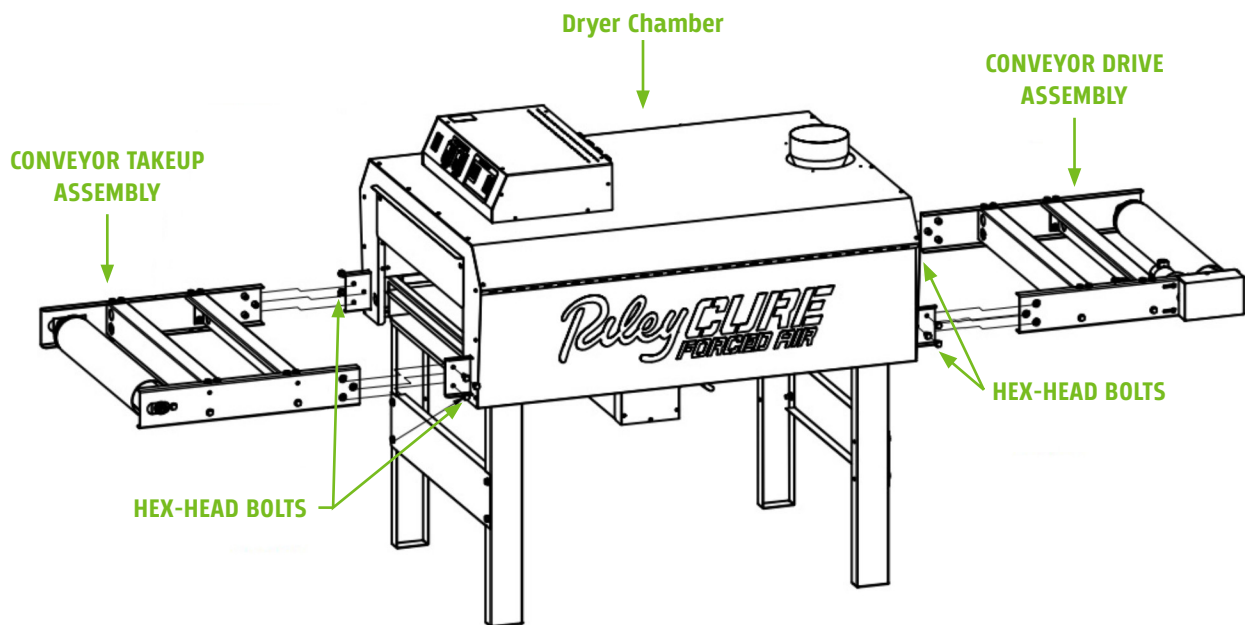

FIGURE 1 - DRYER ASSEMBLY

1. Remove DRYER CHAMBER from crate.
2. CONVEYOR DRIVE ASSEMBLY:
 - a. Locate the Assembly. It consists of a 4" roller and drive motor among other parts.
 - a. Fit the Conveyor Rails inside the rails protruding from the Dryer Chamber and using (6X) of the provided 5/16" Bolts, attach the assembly.
 - b. Route the plug connector through the holes in the Cross-Members.
 - c. Connect the plug to the socket on the heater frame. Push the connector until fully seated.
3. TAKE-UP ASSEMBLY:
 - a. Locate the Assembly. It consists of a 4" roller mounted through some sliding bearing assemblies among other parts.
 - b. Fit the Conveyor Rails inside the rails protruding from the DRYER CHAMBER and using (6X) of the provided 5/16" Bolts, attach the assembly.

4. CONVEYOR BELT:

- a.** You are going to need an assistant for this step in the assembly.
- b.** Loosen (but do not remove) the bolts holding the sliding bearing assemblies on the TAKE-UP ASSEMBLY.
- c.** Locate the end of the CONVEYOR BELT that contains the splice pin.
- d.** Remove the pin, but DO NOT bend or discard this pin. You will reinsert it later.
- e.** The TrueTrak™ Rubber Edge Guide on the CONVEYOR BELT is designed to ride in the groove on the Drum Roller.
- f.** Feed the CONVEYOR BELT through the DRYER CHAMBER then around an end roller and back through the lower chamber.
- g.** Bring the ends of the CONVEYOR BELT together. Use a straightedge on the Edge Guide side of the belt to assure alignment when you mesh the teeth of the splice. If you are just one tooth off, the BELT may jump the edge groove.
- h.** While your assistant holds the ends of the CONVEYOR BELT together, properly mesh the teeth and reinsert the splice pin. The needle-nose pliers will be needed for the last inch or so.
- i.** Move to the TAKE-UP end of your Dryer.
- j.** Pull on the Roller Drum by hand to remove some slack from the belt and tighten the bolt on the bearing assemblies. No need for super-human strength here, too tight and the splice can be damaged over time.

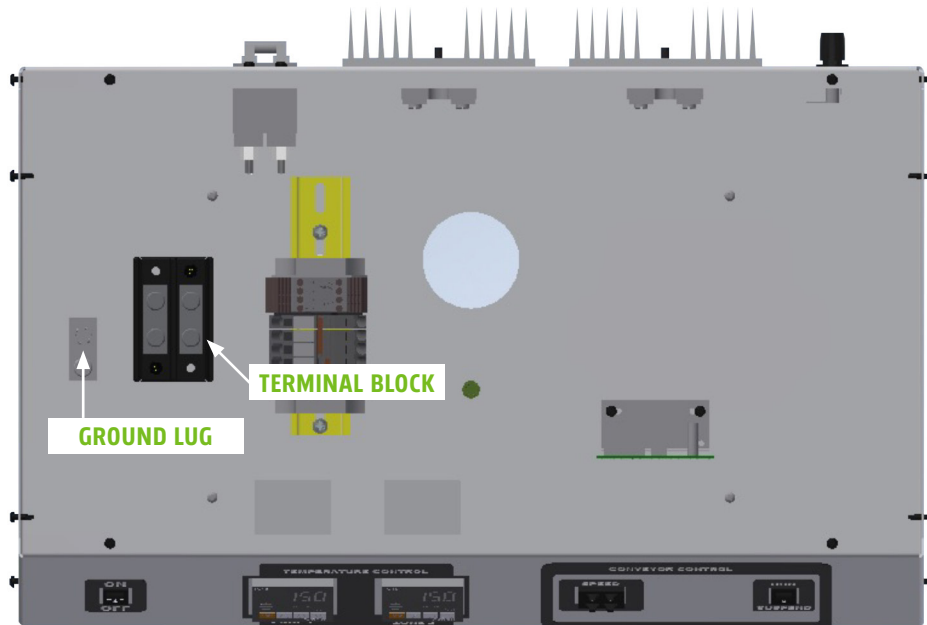

FIGURE 2 - SINGLE PHASE CONTROL PANEL

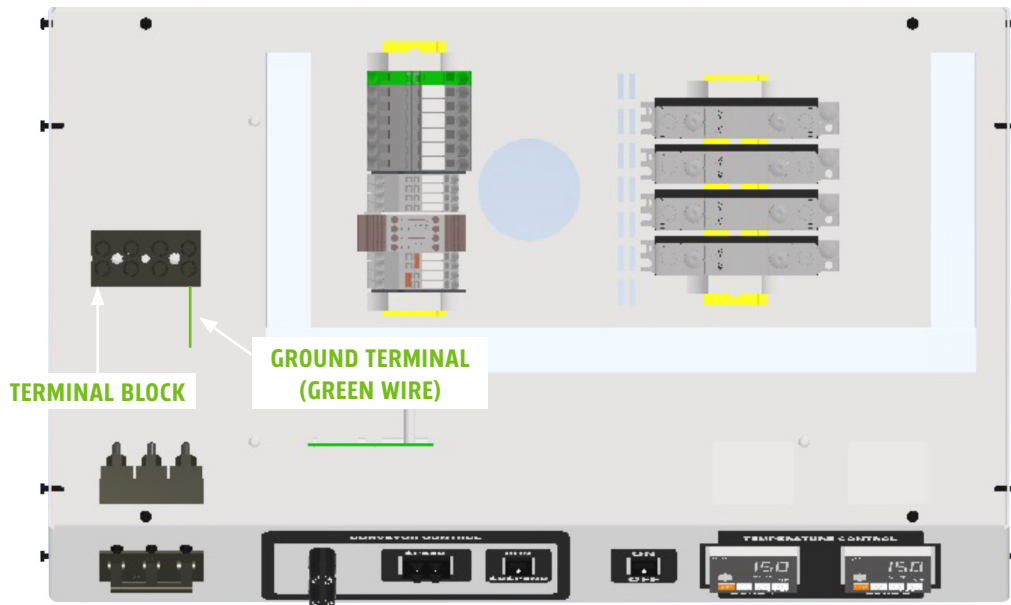

FIGURE 3 - THREE PHASE CONTROL PANEL

Connecting Unit to Power

This unit is not supplied with a power cord. Have a certified electrician connect the unit to power in accordance with local electrical codes.

/// DANGER ///

Before servicing or cleaning, switch power **OFF** at service panel and lock service panel to prevent dryer from being switched on accidentally. If service panel cannot be locked, securely fasten a prominent warning device, such as a tag, to the service panel.

/// DANGER ///

DO NOT OPERATE DRYER WITHOUT COVERS IN PLACE

1. Using a Phillips screwdriver, remove **CONTROL PANEL COVER**.
2. Strip cord jacket exposing enough of the lead wire to connect to appropriate terminal blocks.
Note: The ¾” starter hole for the cord is NOT appropriately sized. You may have to increase this hole size to fit your cord grip.
3. Insert and tighten green grounding lead wire from cord into GROUNDING LUG or GROUNDING TERMINAL across from green wire.
4. Place the POWER leads into the open side of the large TERMINAL BLOCK and tighten set screws. BE SURE NOT TO CLOSE WIRE INSULATION IN TERMINAL BLOCK. (FIG. 2 & 3)
5. Once all connections have been made, tug on the leads to make sure they are fully secured.
6. Replace the CONTROL PANEL COVER. Be careful not to pinch any leads.

Operating Instructions:

The **RileyCURE FORCED AIR DRYER** (Combination Forced Air / Infrared Dryer) is designed to cure both Plastisol & Water-Based screen print inks as well as Digital Ink-Jet printer inks with utmost efficiency. Two different temperature dials are available to allow for maximum production. By setting **Zone 1** higher than **Zone 2**, your dryer will have a profile that plateaus, allowing faster cure times by obtaining higher shirt temps early in the process and holding those temperatures without surpassing scorching temperatures. The Forced Air is essential for all water-based inks, whether screen-printed or digitally printed. The blower constantly introduces fresh, hot, dry air into the curing chamber. It does not recycle saturated humid air within the chamber like other dryers. The Forced Air cannot be turned **OFF** as it is also used to insulate the dryer and keep the outside skin cool.

Operation:

1. Flip switches for Conveyor Belt and Heat (if desired) to ON position.
2. The display on the temperature controller shows the current element temperature.

Note: This is not the air temperature inside the dryer, rather the temperature of the heating element itself.

Press the _____, _____, and _____ keys to show and change the Set-Point Temperature then _____ to enter.

3. The conveyor display on the speed controller is from 00 to 99. The correct speed will need to be tested and adjusted for.
4. Press the + & - keys to adjust each digit.
5. Once the temperature has reached the Set-Point, allow an additional 5 minutes for the dryer to reach equilibrium.
6. If temperature setting is changed, allow 5 minutes for dryer to reach equilibrium. (Longer is fine too)

Listed below are suggested initial settings for your **FORCED AIR DRYER**. There are many factors that influence the curing of different inks. **Test prints need to be produced and wash-tested to determine the best possible settings for your application.**

Table 1 – Suggested Settings for Initial Startup.

INK TYPE	ZONE 1	ZONE 2	CONVEYOR SPEED
Plastisol	900°F	700°F	00:30
Screen Printed Water-Based	800°F	600°F	1:00
Digital Ink-Jet	750°F	550°F	2:00

Your dryer setting will likely be different than those listed above. This table is a suggested starting point. If your shirts are scorching, it is too hot. If they are not fully cured, the dryer needs to be turned up. Allow the dryer to ‘soak’ at the new setting for a few minutes before running product through it at the new setting.

(TIP: Change only 1 setting at a time. Changing multiple settings can result in confusion and longer discovery of proper cure settings.)

Washing the garments is your definitive test on the effectiveness of the dryer settings. Test and retest until you have found a setting for your dryer, your shirts, and your inks. Your customers will appreciate it!

BASIC TROUBLE SHOOTING

If dryer does not hold temperature at set-point (within 5° – 10°F), check the following components:

- A.** Confirm the dryer is getting proper voltage. A drop in voltage will decrease the temperatures in the dryer.
- B.** Reduce any drafts or air currents such as open doors, fans, air conditioners that could be blowing into the chamber. Do not direct fans at the dryer this will cause temperature variations in the chamber.
- C.** If temperature controller displays “OPEN”, then the thermocouple has failed or become disconnected. Replace if necessary.
- D.** If temperature does not rise at all or passes through set-point and continues to heat, Solid State Relay (SSR) may have failed. It can fail in the open or closed position. Replace if necessary.

If Conveyor Belt or Forced Air blower stops, check to see if fuse on backside of Control Panel has tripped. Push to reset.

Control Panel Maintenance:

Performed at initial installation, 30 days after initial installation, and 120 days after initial installation.

1. Turn OFF the power serving the main control panel where it is connected to the building electrical distribution system. Unplug the unit.

Note: Assure that appropriate “Lock-Out / Tag-Out” procedures are followed before conducting any of these activities.

/// IMPORTANT NOTICE ///

2. After double checking that the power is off, confirm that all electrical terminations inside of the main control panel are secure by checking the “tightness” of each termination screw (or wire nut as may be applicable) and then “tugging” on each conductor.

MANUFACTURER'S WARRANTY

All products are warranted against defects in workmanship at the time of shipment. The obligation under the above warranty shall be limited to the repair or replacement of any part or parts manufactured by the dryer manufacturer without charge F.O.B. factory that may prove defective within 12 months from the date of shipment, which are returned to dryer manufacturer. The above warranties are the only warranties made with respect to the equipment. There is no implied warranty of merchantability or of fitness.

EXCLUSIONS: There is no warranty on parts not manufactured by the dryer manufacturer, other than the respective manufacturer's warranty, if any. The warranty against defects shall not extend to damage caused from any of the following:

- Transport by carrier
- Corrosion
- Operation or use in a manner inconsistent with specifications and/or operating instructions
- Ordinary wear, accident, improper installation, or maintenance
- Alterations made to equipment in any way

Dryer manufacturer shall not be liable for losses or damages, including but not limited to incidental or consequential damages, suffered or incurred because the equipment proves to be defective either upon installation or during its operation or use. Shipment of defective parts to the dryer manufacturer and the return shipment of any repaired or replacement parts from the dryer manufacturer shall be the purchaser's/user's expense.

