



**Power Lite (Plus) Wiring Examples for models:
L051100-A, L051100-A1, L051100-B, L051100-D**

Ver. 1.5

Click for the corresponding section:



No inverter communication (open-loop)



CAN inverter communication (closed-loop)



Introduction.....	2
Battery Communication	2
Power Wiring	3
General Battery Quantities.....	3
Wiring Legend.....	4
Deye.....	5
Goodwe	8
Growatt.....	11
Luxpower.....	14
Phocos (Open-Loop).....	17
SAJ	20
SMA	23
Sofar	26
Sol-Ark.....	29
Solis	32
Steca (Open-Loop)	36
Voltronic Power (Open-Loop).....	39
Voltronic Power (Closed-Loop).....	42

Introduction

This document is intended to show examples of how to wire UZ Energy batteries with photovoltaic hybrid inverters. All installations must be performed by trained electricians and UZ Energy bears no responsibility for incorrect installation or lack of adherence to local electrical regulations. Make sure to respect all safety indications from the UZ Energy battery manual for your particular battery model.

These examples show wiring and bus bars of the main inverter to battery connections, battery management system data wiring, as well as mandatory DC breakers. Other connections such as AC or photovoltaic (PV) connections are intentionally omitted, refer to the inverter manuals for more details. Additional equipment may be required for your installation. These examples apply to the following UZ Energy battery models (see [Battery Communication](#) for differences in wiring between models):

- All Power Lite series (L051100-A, L051100-A1, L051100-B and L051100-D)
- All Power Lite Plus series

All examples apply to 51.2Vdc nominal battery voltage systems only.

Any examples labeled “open-loop” refer to setups without digital communication between the inverters and the batteries. While communication with the inverter is not required, it brings advantages in that the inverter can react to warnings coming from the battery management system (BMS) that is integrated in each individual battery. The safety of the batteries is ensured in either case via the protective BMS functions.

Any inverter images and manufacturer logos used in this document are for illustrative purposes only, their copyright remains with the respective inverter manufacturers.

Battery Communication

The Power Lite (Plus) series batteries can communicate with inverters via a CAN bus port. This document outlines with which inverters the CAN communication is compatible (if available) and what the pinout of the connectors is in the inverter-specific sections. The batteries’ CAN port has the following relevant pinout from the perspective of looking on the RJ45 connector on the battery front face:

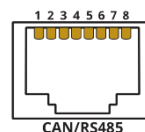

Pin	1	2	3	4	5	6	7	8
Function	CAN-H	RS485-A	RS485-B	NC	CAN-L	RS485-B	RS485-A	GND

Note: “NC” means not connected.

Warning: Only connect to the CAN-H, CAN-L and GND/ground pins (only if GND is mentioned in the pin-out of the various inverters) and **leave all other pins disconnected** for CAN communication. Some inverters have high voltages on some of their pins that could damage the battery and for some inverters connecting the GND/ground wire is not recommended. Some pins are also reserved by the inverter for synchronization or other functions, which could be disrupted if connected to. Damage to the battery or inverter by incorrect wiring is **not covered under warranty**.

Please note there are differences for the communication wiring depending on the Power Lite model:

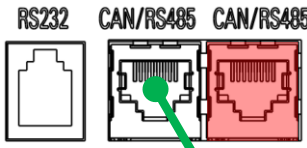
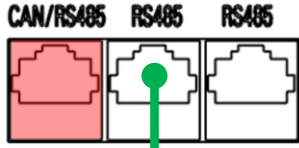
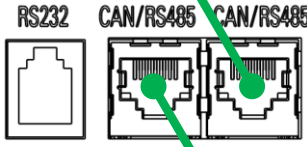
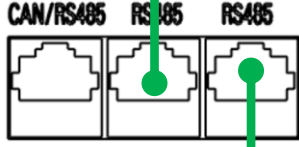
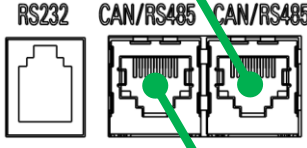
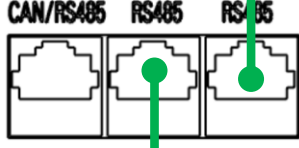
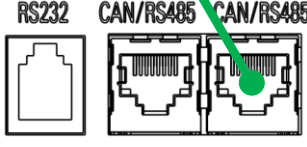
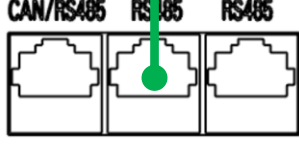
Battery model	L051100-A	L051100-A1, L051100-B and L051100-D
Connection Socket from Master Battery to Inverter (except open-loop systems) marked Red		
Connection from Master to Slave Batteries with included Cables marked Green (except <u>Voltronic Power (Closed-Loop)</u>)		
		
		

Power Wiring

The maximum continuous current per battery and power connector is 100 Adc. As the total battery current for parallel batteries is added at the common positive and negative terminals connecting to the inverter(s), a maximum of 2 batteries may be used without busbars so as not to exceed the 100 Adc continuous rating (each battery can supply 50 Adc continuous). For any number of batteries above 2, busbars are required, as well as one 100 ~ 125 Adc breaker per battery, unless the connected inverter(s) are unable to charge and discharge with more than 100 Adc continuous.

The following diagrams for various inverters typically show an example without busbars and therefore 2 batteries and a single breaker. Further diagrams show examples with 3 batteries, busbars and breakers and can be applied for systems with 3 or more batteries (for more than 100 Adc continuous charge and/or discharge current) in the same fashion.

General Battery Quantities

As for all battery technologies, the permitted charge and discharge current and quantity of batteries must be taken into account for a balanced system. The battery quantities recommended for the various inverter models below are to achieve full power (up to the limits of the inverter) for AC loads in situations where no PV and no AC source (such as the grid) are available, so that all power must be sourced from the battery. Using fewer batteries than the recommended values typically is possible but may limit the available AC power in the scenario described above.

To better understand the effect of using less than the recommended battery quantity, here is an example. A single Power Lite is used with an inverter capable of delivering 3 kW to loads when no AC source or PV is present. Because a single battery can sustain 50 A continuous discharge current, the available AC load power will be: battery voltage x 50 Adc x inverter efficiency. Please note that by inverter efficiency, we are referring to the efficiency of the battery (DC) to the AC output (AC conversion) in percent. Assuming an inverter



efficiency of 95% and a battery voltage of 50 Vdc, this would make $50 \text{ Vdc} \times 50 \text{ Adc} \times 95\% = 2375 \text{ W}$ available for AC loads when sourcing only from the battery. Please make sure to also set the maximum inverter charge and discharge current to an appropriate value, depending on the actual number of batteries used.

Wiring Legend

This legend applies to all wiring examples.

■ DC Power Negative (-)

■ DC Power Positive (+)

■ Ground

■ CAN (between battery Master and inverter) & RS-485 (between Master and Slave batteries, included with the batteries) Communication Wiring: see the CAN Communication Pinout sections of the various Inverters



Deye

These examples apply to the following Deye inverters:

- SUN-SG01LP1 series
- SUN-SG03LP1 series

and show L051100-A Power Lite batteries. See [Battery Communication](#) for details regarding -A1, -B and -D Power Lite batteries.

Inverter Firmware Version

The minimum firmware requirement is:

- For inverter model: SUN-8K-SG01LP1-EU
Firmware: 1870
- For inverter model: GSL-H-7.6K-US-B
Firmware: 5976/5209

CAN Communication Pinout

Deye inverters have the following relevant CAN pinout:

Pin	1	2	3	4	5	6	7	8
Function		GND		CAN-H	CAN-L			

See section [Battery Communication](#) for the corresponding pins on the battery.

Battery Quantities

The following quantities of batteries are recommended (see section [General Battery Quantities](#) for details), while of course more batteries can be used.

Inverter Model	AC Phases	AC Power Cont.	Max. Charge / Discharge Current Cont.	Power Lite Recommended Battery Qty.
SUN-3.6K-SG03LP1	1	3,600 W	90 A	2
SUN-5K-SG03LP1	1	5,000 W	120 A	3
SUN-6K-SG03LP1	1	6,000 W	135 A	3
SUN-8K-SG01LP1	1	8,000 W	190 A	4

Example for up to 2 Batteries

No bus bar required, and a single battery breaker is sufficient.

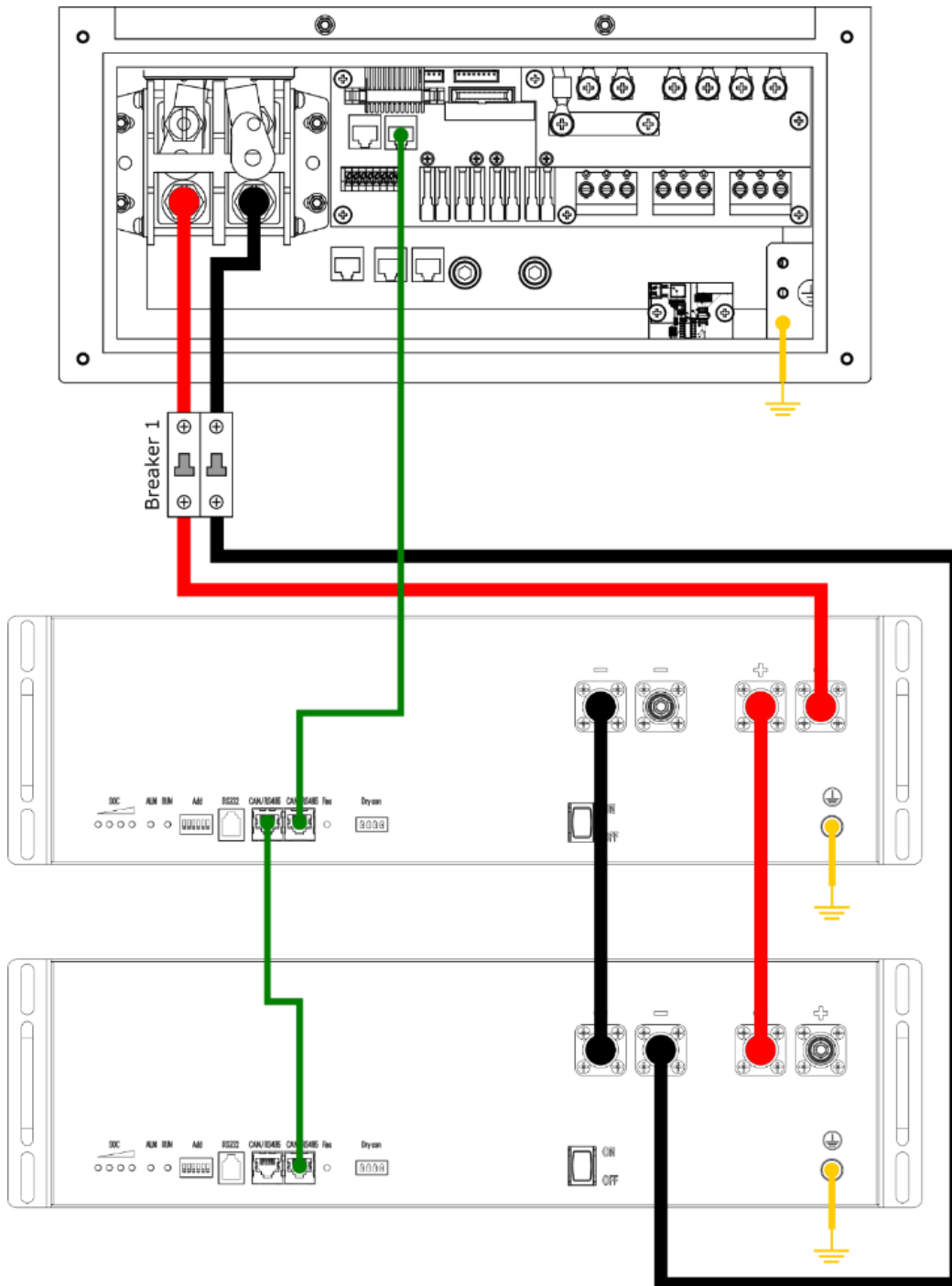

Example for 3 and more Batteries

Bus bar is required and a battery breaker per battery is needed.

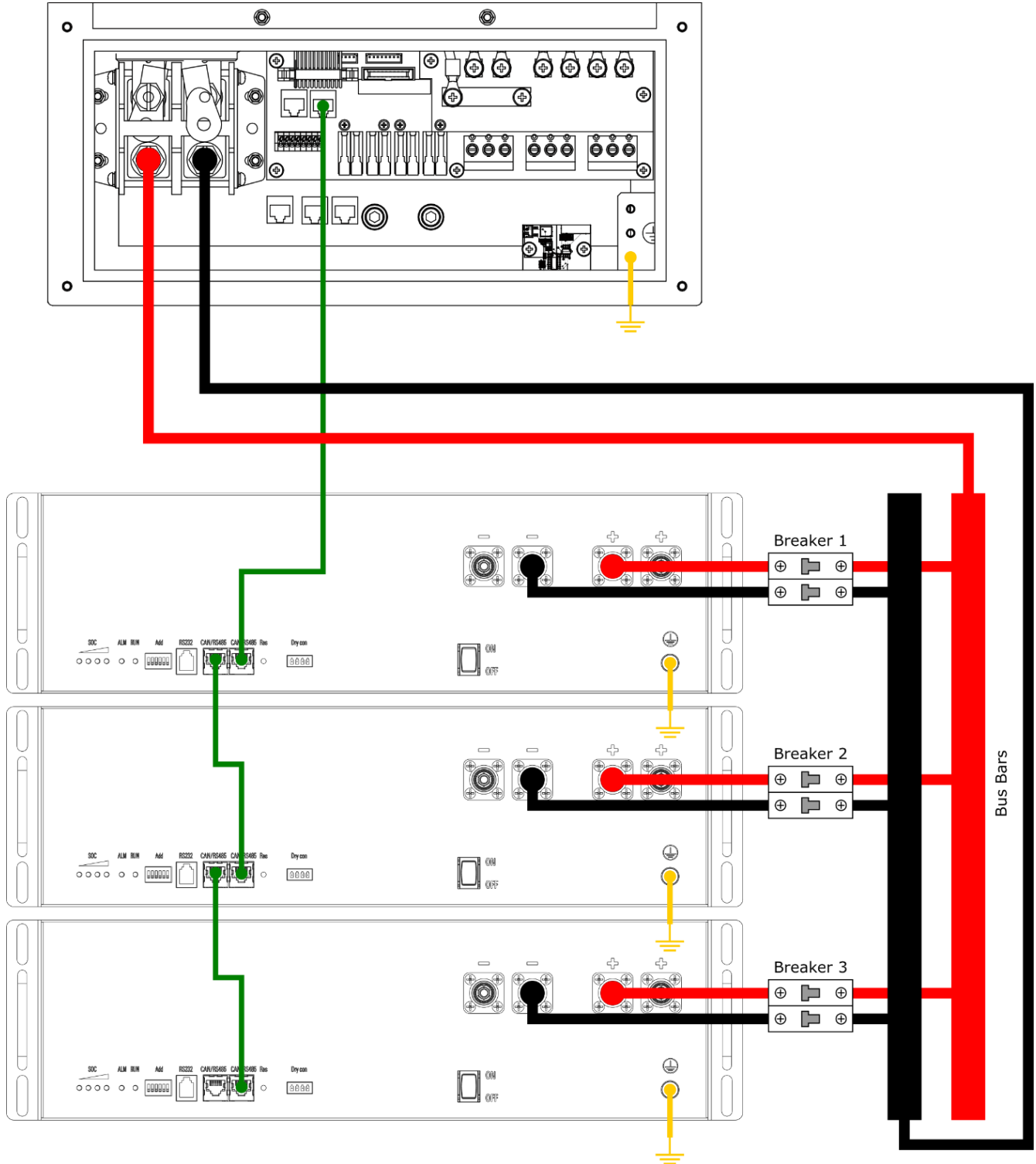

Goodwe

These examples apply to the following Goodwe inverters:

- GW-BP/SBP series
- GW-ES/EM series

and show L051100-A Power Lite batteries. See [Battery Communication](#) for details regarding -A1, -B and -D Power Lite batteries.

Inverter Firmware Version

The minimum firmware requirement is:

- For inverter model: GW5048D-ES
Firmware: 2121C

CAN Communication Pinout

Goodwe inverters have the following relevant CAN pinout:

Pin	1	2	3	4	5	6	7	8
Function				CAN-H	CAN-L			

See section [Battery Communication](#) for the corresponding pins on the battery.

Battery Quantities

The following quantities of batteries are recommended (see section [General Battery Quantities](#) for details), while of course more batteries can be used.

Inverter Model	AC Phases	AC Power Cont.	Max. Charge / Discharge Current Cont.	Power Lite Recommended Battery Qty.
GW3600S-BP	1	3,600 W	75 A	2
GW5000S-BP	1	5,000 W	100 A	2
GW3648D-ES	1	3,680 W	75 A	2
GW5048D-ES	1	5,000 W	100 A	2
GW3048-EM	1	3,000 W	50 A	1
GW3648-EM	1	3,680 W	50 A	1
GW5048-EM	1	5,000 W	50 A	1

Example for up to 2 Batteries

No bus bar required, and a single battery breaker is sufficient.

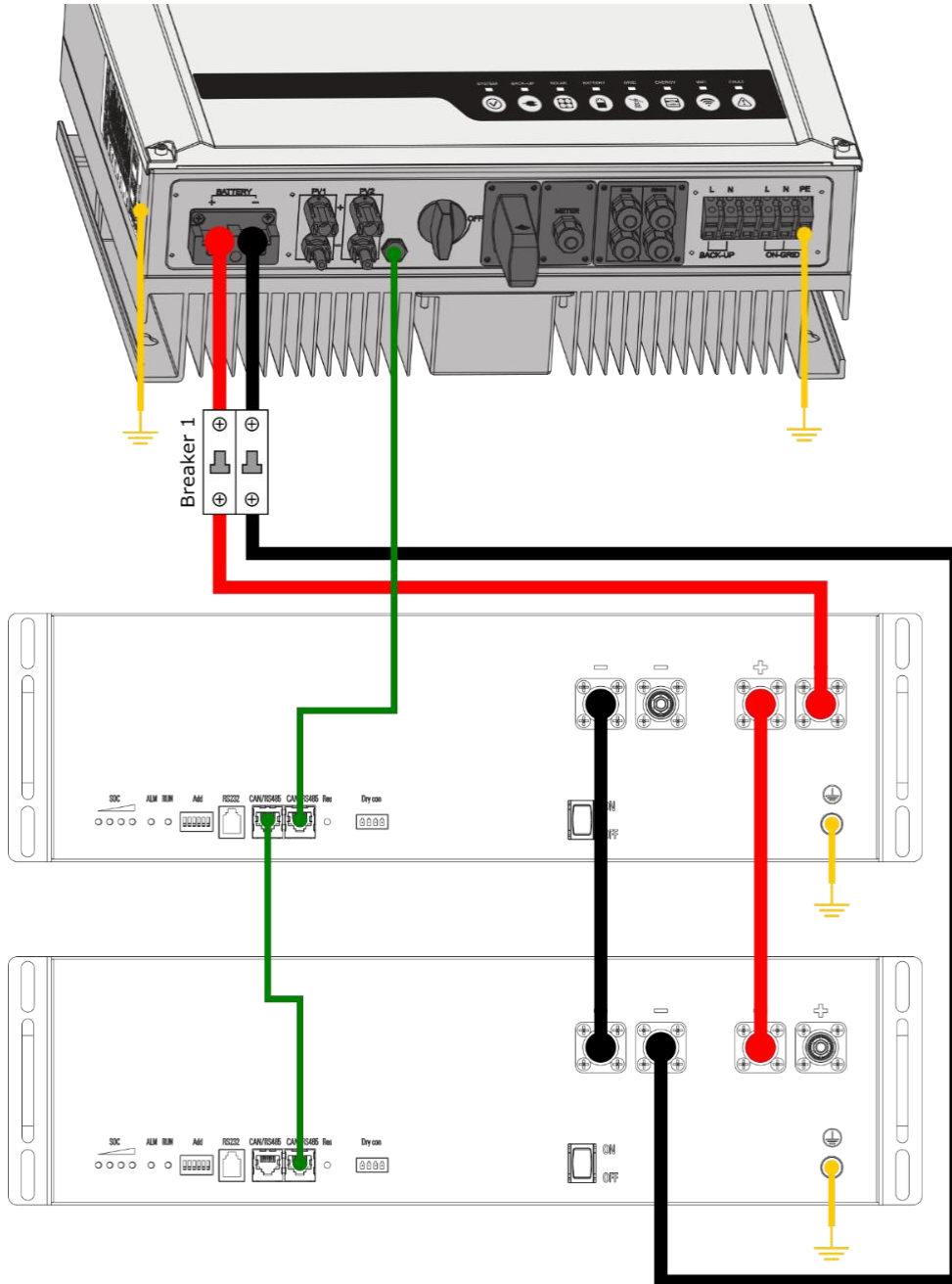

Example for 3 and more Batteries

Bus bar is required and a battery breaker per battery is needed.

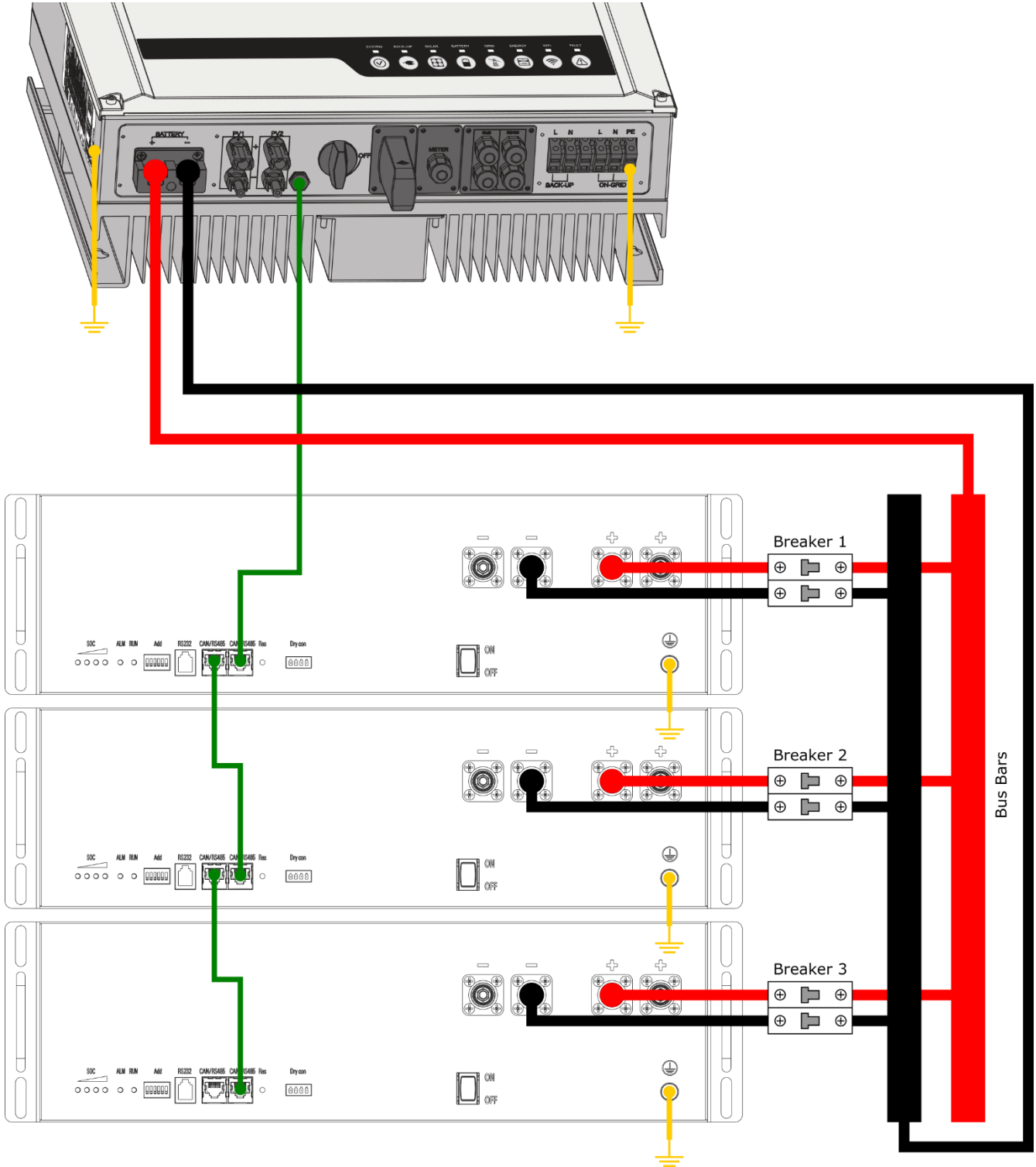

Growatt

These examples apply to the following Growatt inverters:

- SPH 6000
- SPH 5000TL

and show L051100-A Power Lite batteries. See [Battery Communication](#) for details regarding -A1, -B and -D Power Lite batteries.

Inverter Firmware Version

The minimum firmware requirement is:

- For inverter model: SPH5000TL BL-UP
Firmware: RA1.0

CAN Communication Pinout

Growatt inverters have the following relevant CAN pinout:

Pin	1	2	3	4	5	6	7	8
Function		GND		CAN-H	CAN-L			

See section [Battery Communication](#) for the corresponding pins on the battery.

Battery Quantities

The following quantities of batteries are recommended (see section [General Battery Quantities](#) for details), while of course more batteries can be used.

Inverter Model	AC Phases	AC Power Cont.	Max. Charge / Discharge Power Cont.	Power Lite Recommended Battery Qty.
SPH 5000	1	5,000 W	3000 W	2
SPH 6000	1	6,000 W	3000 W	2

Example for up to 2 Batteries

No bus bar required, and a single battery breaker is sufficient.

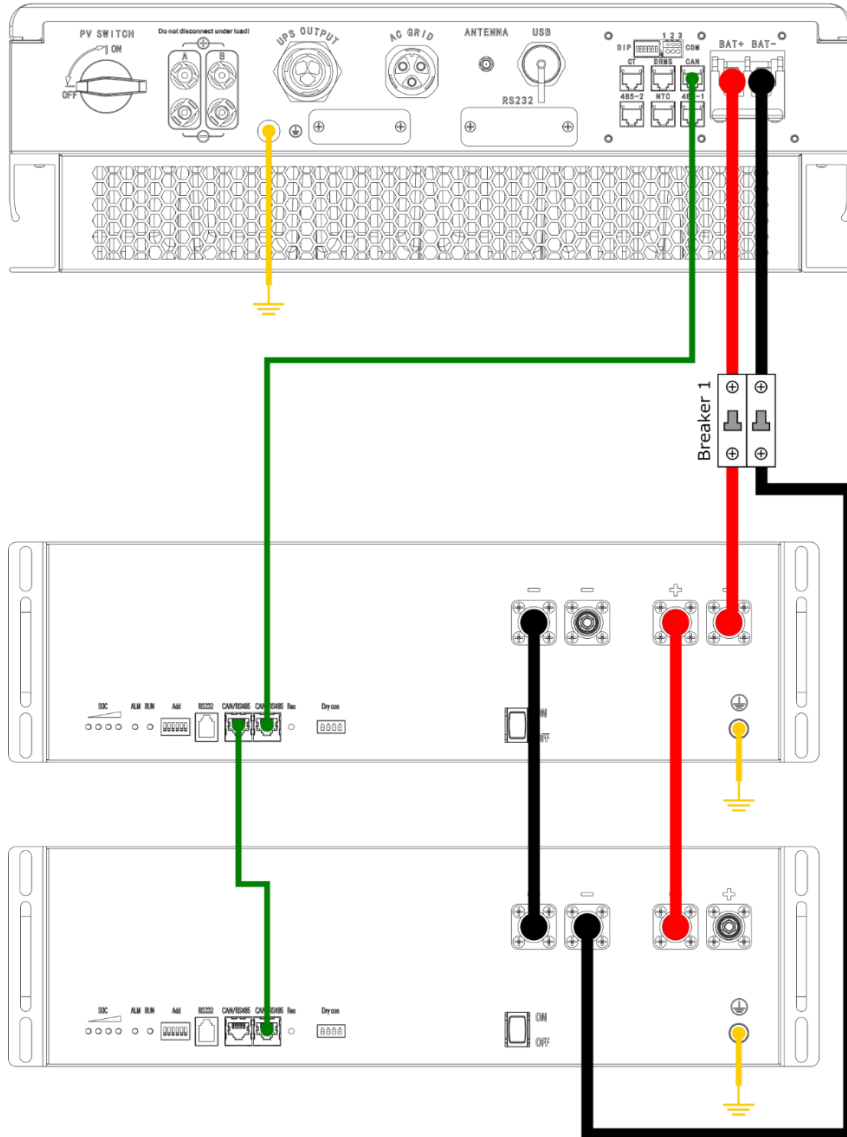

Example for 3 and more Batteries

Bus bar is required and a battery breaker per battery is needed.

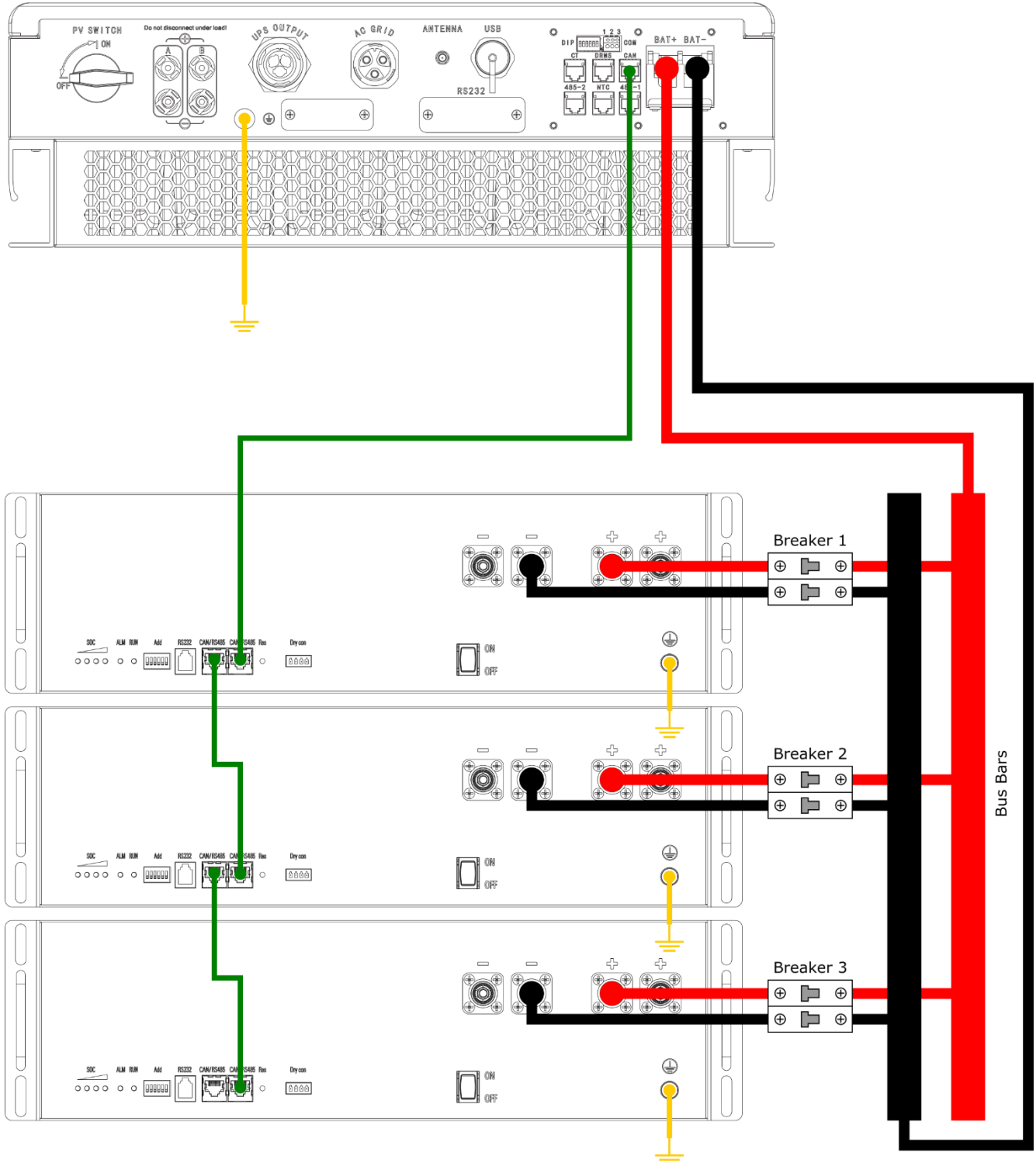

Luxpower

These examples apply to the following Luxpower inverters:

- LXP Hybrid/ACS series

and show L051100-A Power Lite batteries. See [Battery Communication](#) for details regarding -A1, -B and -D Power Lite batteries.

Inverter Firmware Version

The minimum firmware requirement is:

- For inverter model: LXP-3.6K Hybrid
Firmware: AAAA-1719

CAN Communication Pinout

Luxpower inverters have the following relevant CAN pinout:

Pin	1	2	3	4	5	6	7	8
Function			CAN-L	CAN-H				GND

See section [Battery Communication](#) for the corresponding pins on the battery.

Battery Quantities

The following quantities of batteries are recommended (see section [General Battery Quantities](#) for details), while of course more batteries can be used.

Inverter Model	AC Phases	AC Power Cont.	Max. Charge / Discharge Current Cont.	Power Lite Recommended Battery Qty.
LXP-3K Hybrid	1	3,000 W	66 A	2
LXP-3.6K Hybrid	1	3,600 W	80 A	2
LXP-4K Hybrid	1	4,000 W	80 A	2
LXP-4.6K Hybrid	1	4,600 W	80 A	2
LXP-5K Hybrid	1	5,000 W	80 A	2
LXP-6K Hybrid	1	6,000 W	80 A	2
LXP 3600 ACS	1	3,600 W	70 A	2

Example for up to 2 Batteries

No bus bar required, and a single battery breaker is sufficient.

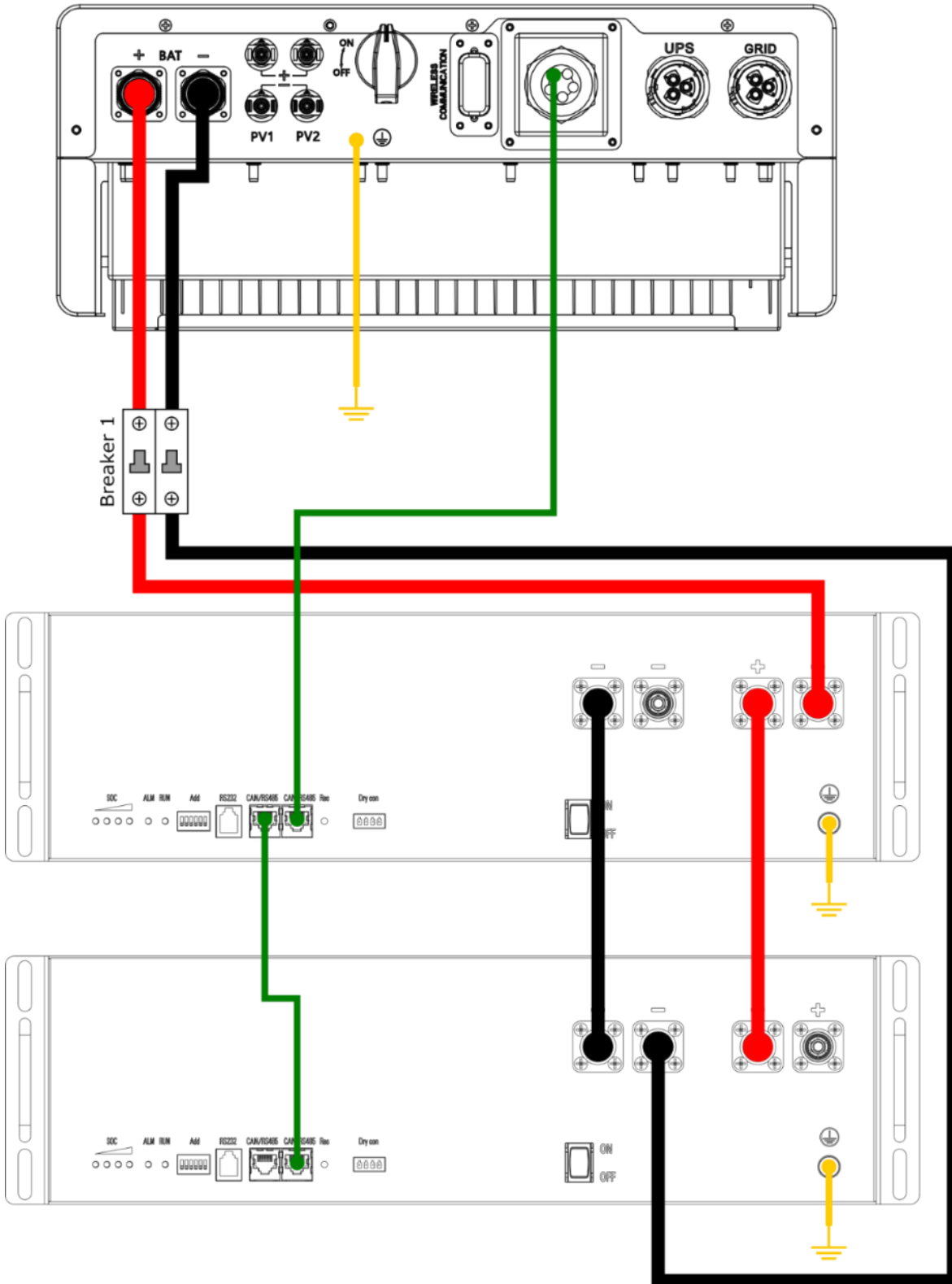

Example for 3 and more Batteries

Bus bar is required and a battery breaker per battery is needed.

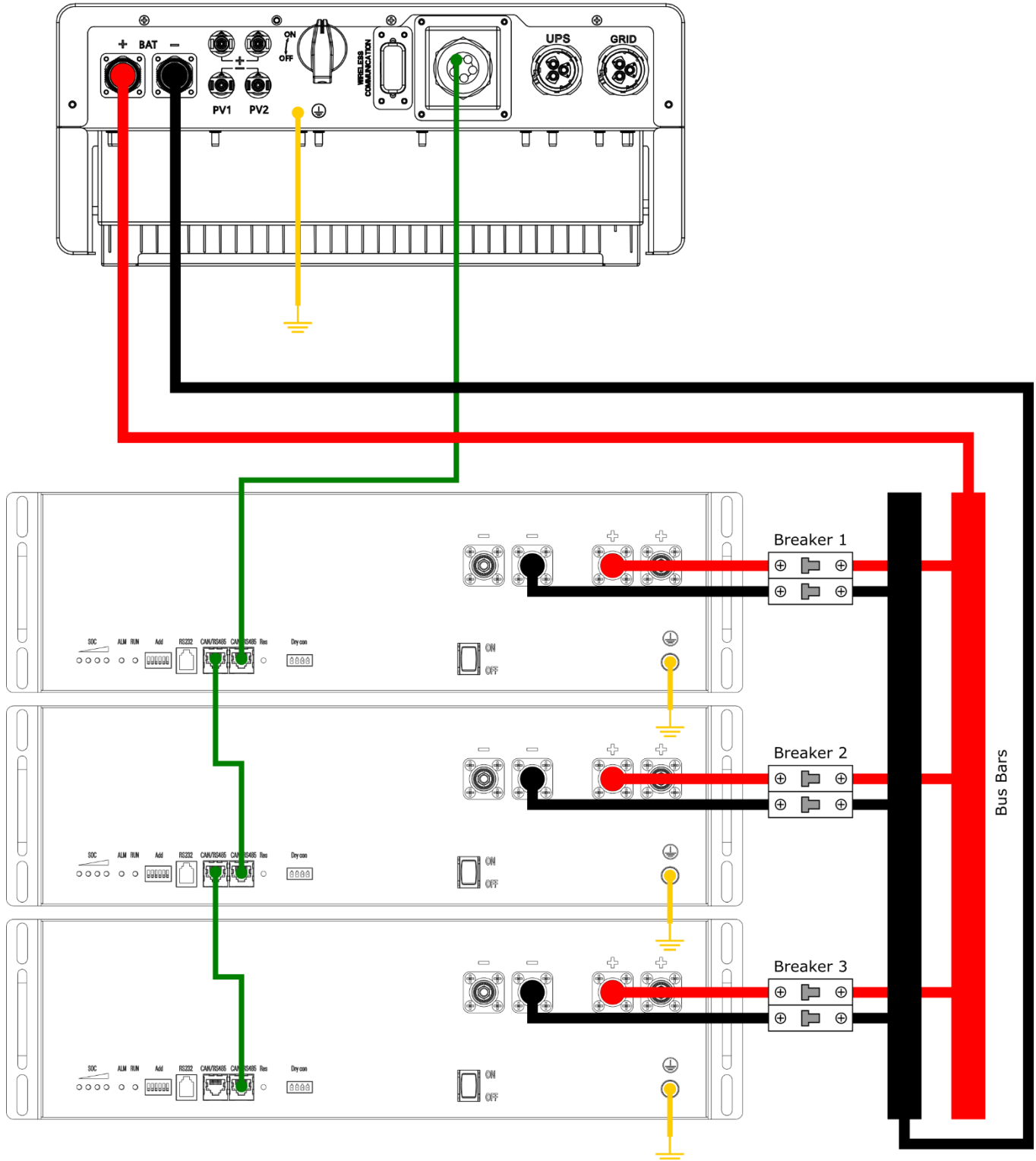



Phocos (Open-Loop)

These examples apply to the following Phocos inverters:

- PSW-H-5KW-230/48V
- PSW-H-5KW-120/48V
- PSW-H-6.5KW-120/48V
- PSW-H-8KW-230/48V

and show L051100-A Power Lite batteries. See [Battery Communication](#) for details regarding -A1, -B and -D Power Lite batteries.

Inverter Firmware Version

There is no minimum firmware requirement.

Communication

No communication is supported nor needed for Phocos inverters.

Battery Quantities

The following quantities of batteries are recommended (see section [General Battery Quantities](#) for details), while of course more batteries can be used.

Inverter Model	AC Phases	AC Power Cont.	Power Lite Recommended Battery Qty.
PSW-H-5KW-230/48V	1	5,000 W	3
PSW-H-5KW-120/48V	1	5,000 W	3
PSW-H-6.5KW-120/48V	1	6,500 W	3
PSW-H-8KW-230/48V	1	8,000 W	4

Example for up to 2 Batteries

No bus bar required, and a single battery breaker is sufficient.

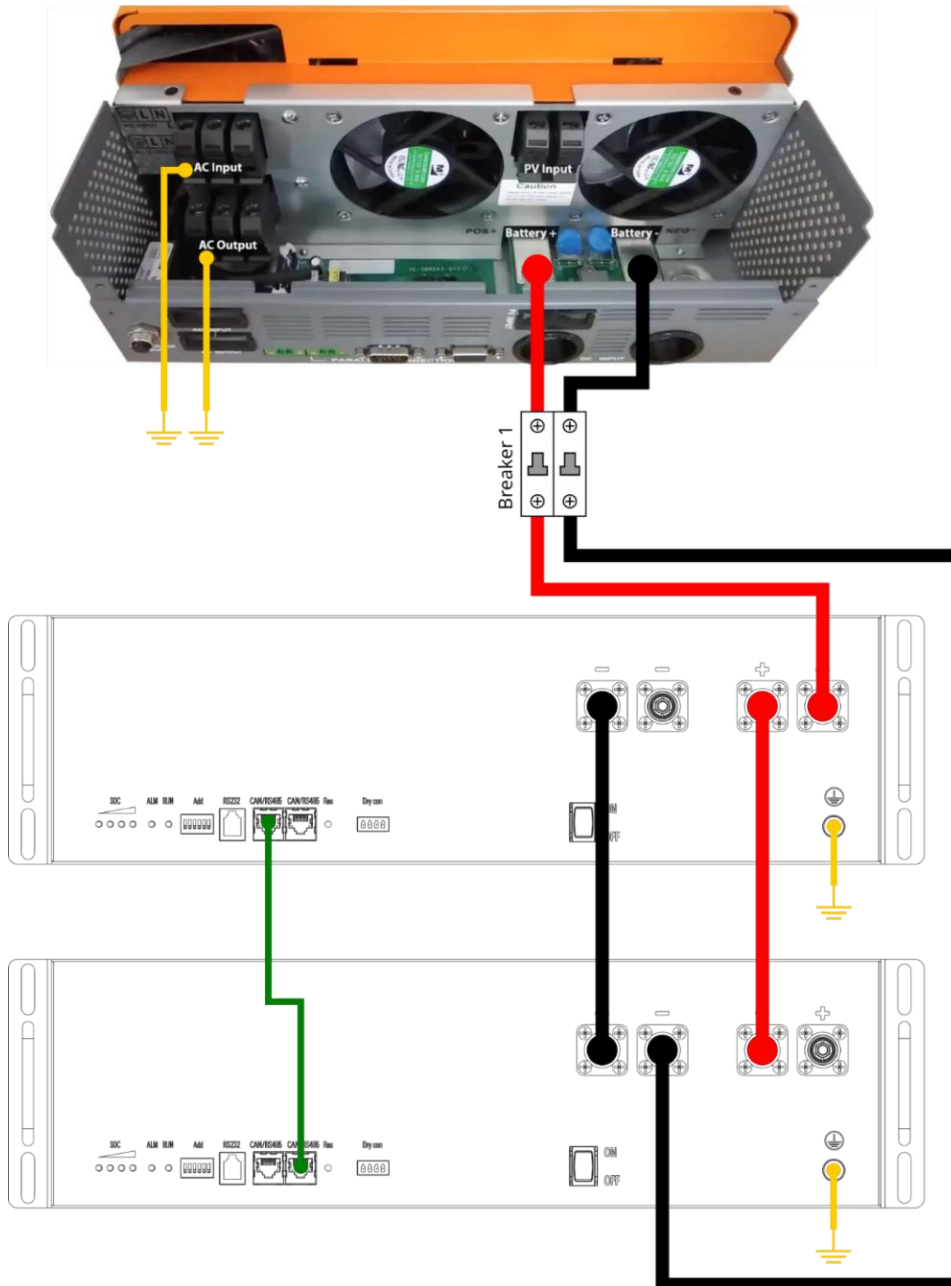

Example for 3 and more Batteries

Bus bar is required and a battery breaker per battery is needed.

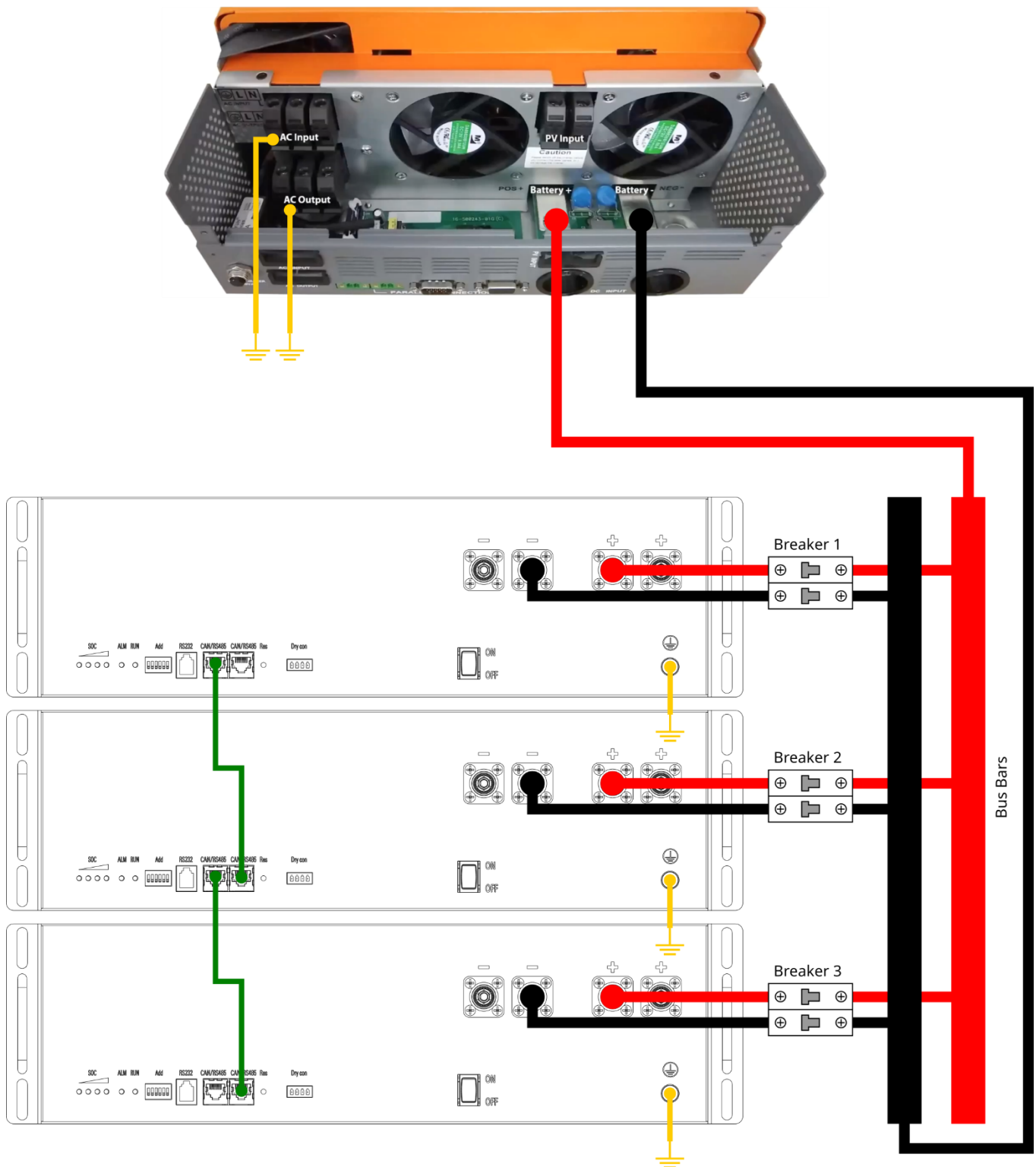



SAJ

These examples apply to the following SAJ inverters:

- H1-3K-S2
- H1-3.6K-S2
- H1-4K-S2
- H1-4.6K-S2
- H1-5K-S2
- H1-6K-S2

and show L051100-A Power Lite batteries. See [Battery Communication](#) for details regarding -A1, -B and -D Power Lite batteries.

Inverter Firmware Version

The minimum firmware requirement is:

- For inverter model: H1-3K-S2
Firmware: V1.325

CAN Communication Pinout

SAJ inverters have the following relevant CAN pinout:

Pin	1	2	3	4	5	6	7	8
Function				CAN-H	CAN-L			

See section [Battery Communication](#) for the corresponding pins on the battery.

Battery Quantities

The following quantities of batteries are recommended (see section [General Battery Quantities](#) for details), while of course more batteries can be used.

Inverter Model	AC Phases	AC Power Cont.	Max. Charge / Discharge Current Cont.	Power Lite Recommended Battery Qty.
H1-3K-S2	1	3,000 W	60 A	2
H1-3.6K-S2	1	3,680 W	60 A	2
H1-4K-S2	1	4,000 W	60 A	2
H1-4.6K-S2	1	4,600 W	100 A	2
H1-5K-S2	1	5,000 W	100 A	2
H1-6K-S2	1	6,000 W	100 A	2

Example for up to 2 Batteries

No bus bar required, and a single battery breaker is sufficient.

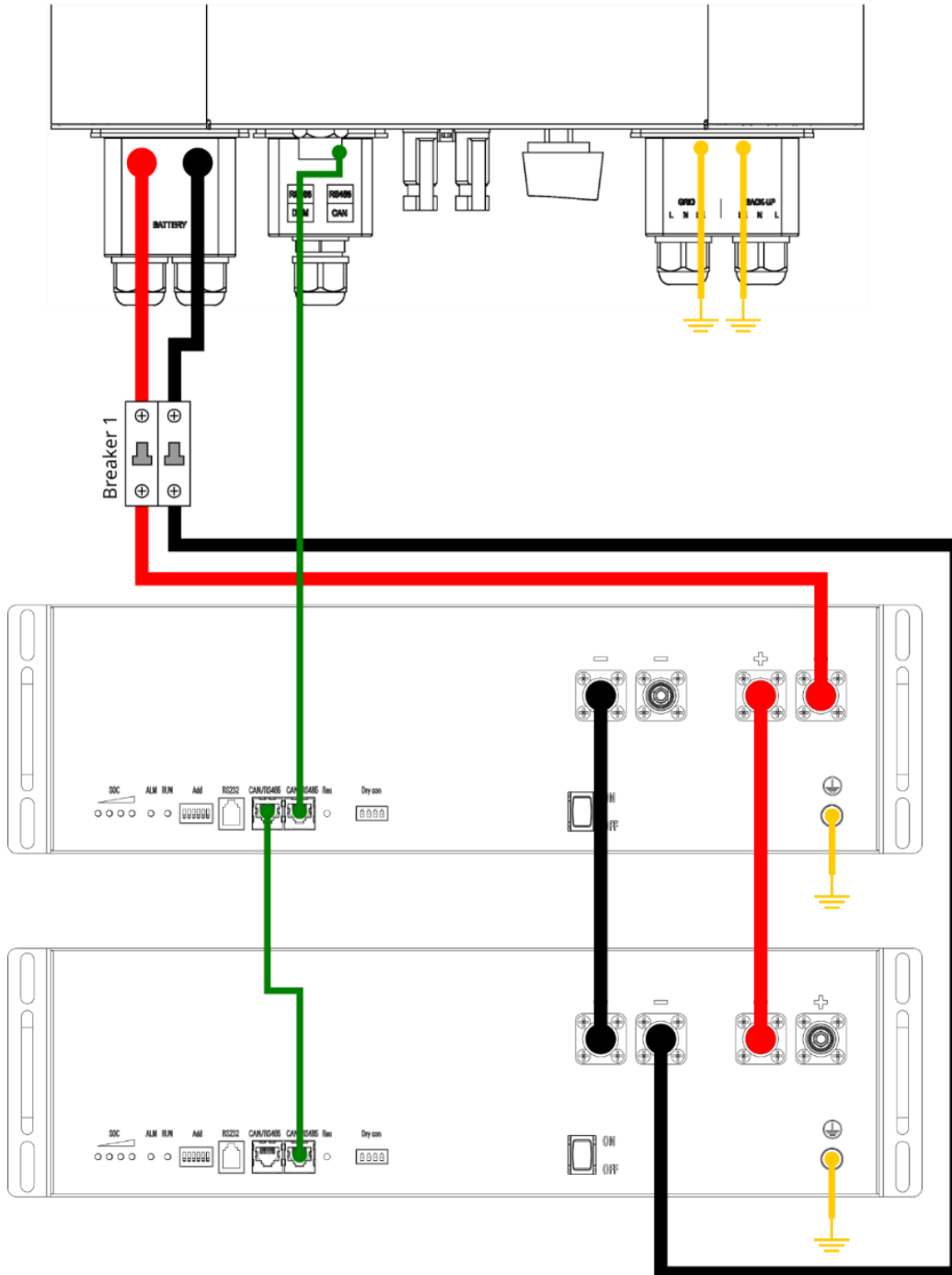

Example for 3 and more Batteries

Bus bar is required and a battery breaker per battery is needed.

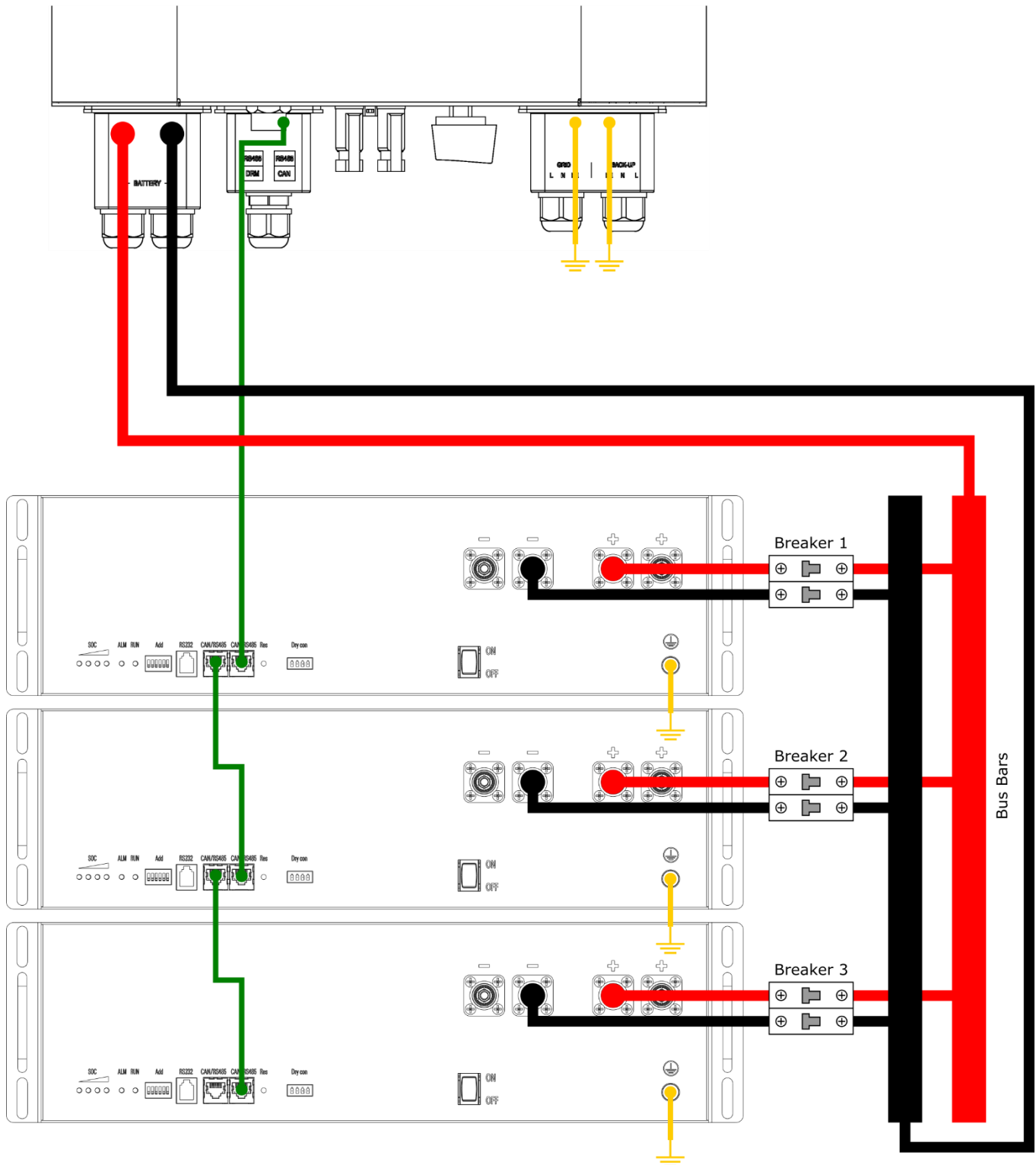

SMA

These examples apply to the following SMA inverters:

- Sunny Island series

and show L051100-A Power Lite batteries. See [Battery Communication](#) for details regarding -A1, -B and -D Power Lite batteries.

Inverter Firmware Version

The minimum firmware requirement is:

- For inverter model: SI 6.0-H
Firmware: 3.21.4.R

CAN Communication Pinout

SMA inverters have the following relevant CAN pinout:

Pin	1	2	3	4	5	6	7	8
Function		GND		CAN-H	CAN-L			

See section [Battery Communication](#) for the corresponding pins on the battery.

Battery Quantities

The following quantities of batteries are recommended (see section [General Battery Quantities](#) for details), while of course more batteries can be used.

Inverter Model	AC Phases	AC Power Cont.	Max. Discharge Current Cont.	Power Lite Recommended Battery Qty.
SI 4.4-M	1	3,300 W	75 A	2
SI 6.0-H	1	4,600 W	103 A	2
SI 8.0-H	1	6,000 W	130 A	3
SI 4.4-M x 3 pcs.	3	9,900 W	225 A	5
SI 6.0-H x 3 pcs.	3	13,800 W	309 A	7
SI 8.0-H x 3 pcs.	3	18,000 W	390 A	8

Example for up to 2 Batteries

No bus bar required, and a single battery breaker is sufficient.

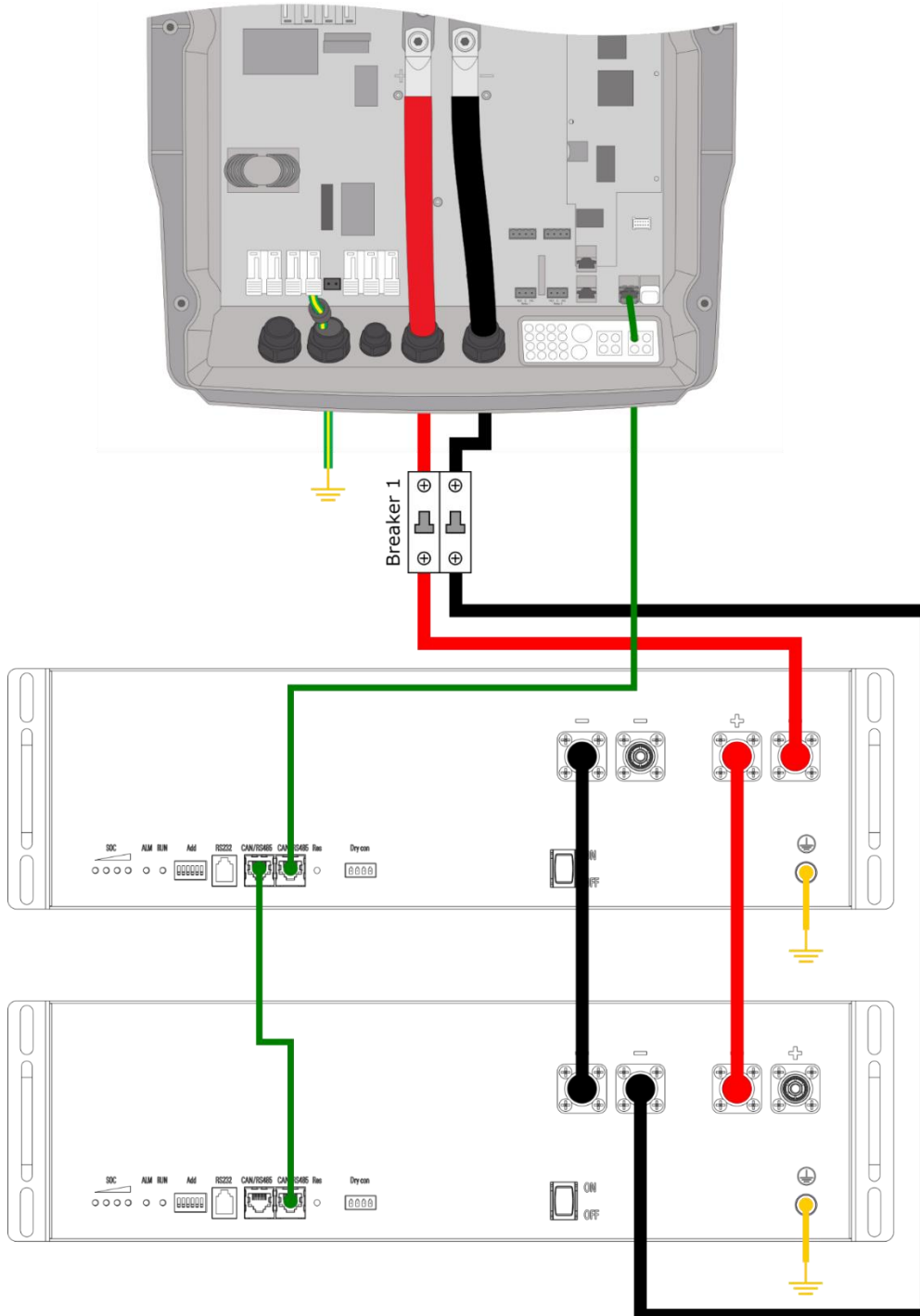

Example for 3 and more Batteries

Bus bar is required and a battery breaker per battery is needed.

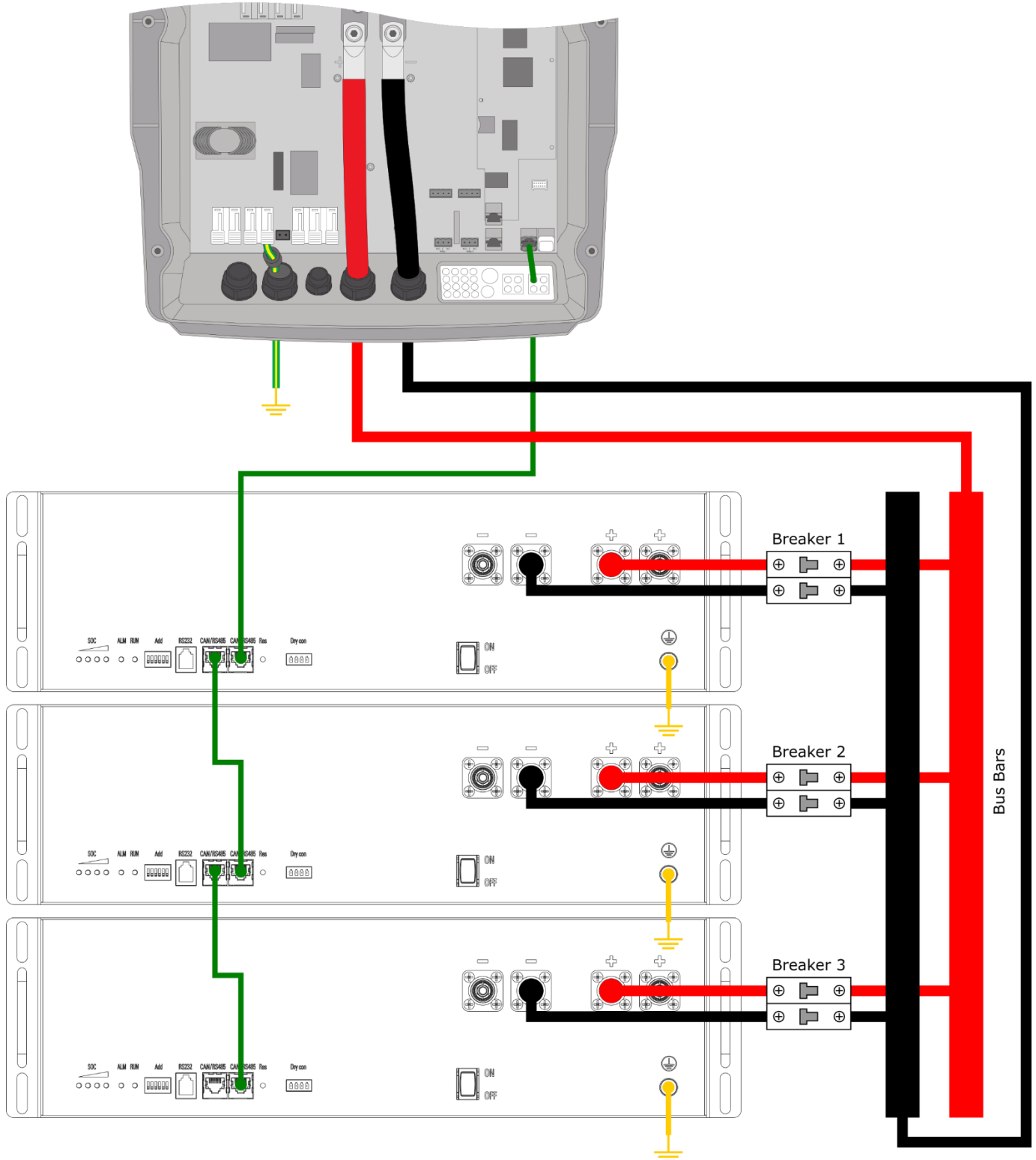

Sofar

These examples apply to the following Sofar inverters:

- ME 3000SP
- HYD series

and show L051100-A Power Lite batteries. See [Battery Communication](#) for details regarding -A1, -B and -D Power Lite batteries.

Inverter Firmware Version

The minimum firmware requirement is:

- For inverter model: HYD6000-EP
Firmware: V030321

CAN Communication Pinout

Sofar inverters have the following relevant CAN pinout:

Pin	1	2	3	4	5	6	7	8
Function	CAN-H	CAN-L						

See section [Battery Communication](#) for the corresponding pins on the battery.

Battery Quantities

The following quantities of batteries are recommended (see section [General Battery Quantities](#) for details), while of course more batteries can be used.

Inverter Model	AC Phases	AC Power Cont.	Max. Charge / Discharge Current Cont.	Power Lite Recommended Battery Qty.
HYD 3000-EP	1	3,000 W	100 A / 100 A	2
HYD 3680-EP	1	3,680 W	100 A / 100 A	2
HYD 4000-EP	1	4,000 W	100 A / 100 A	2
HYD 4600-EP	1	4,600 W	100 A / 100 A	2
HYD 5000-EP	1	5,000 W	100 A / 100 A	2
ME 3000SP	1	3,000 W	65 A / 70 A	2

Example for up to 2 Batteries

No bus bar required, and a single battery breaker is sufficient.

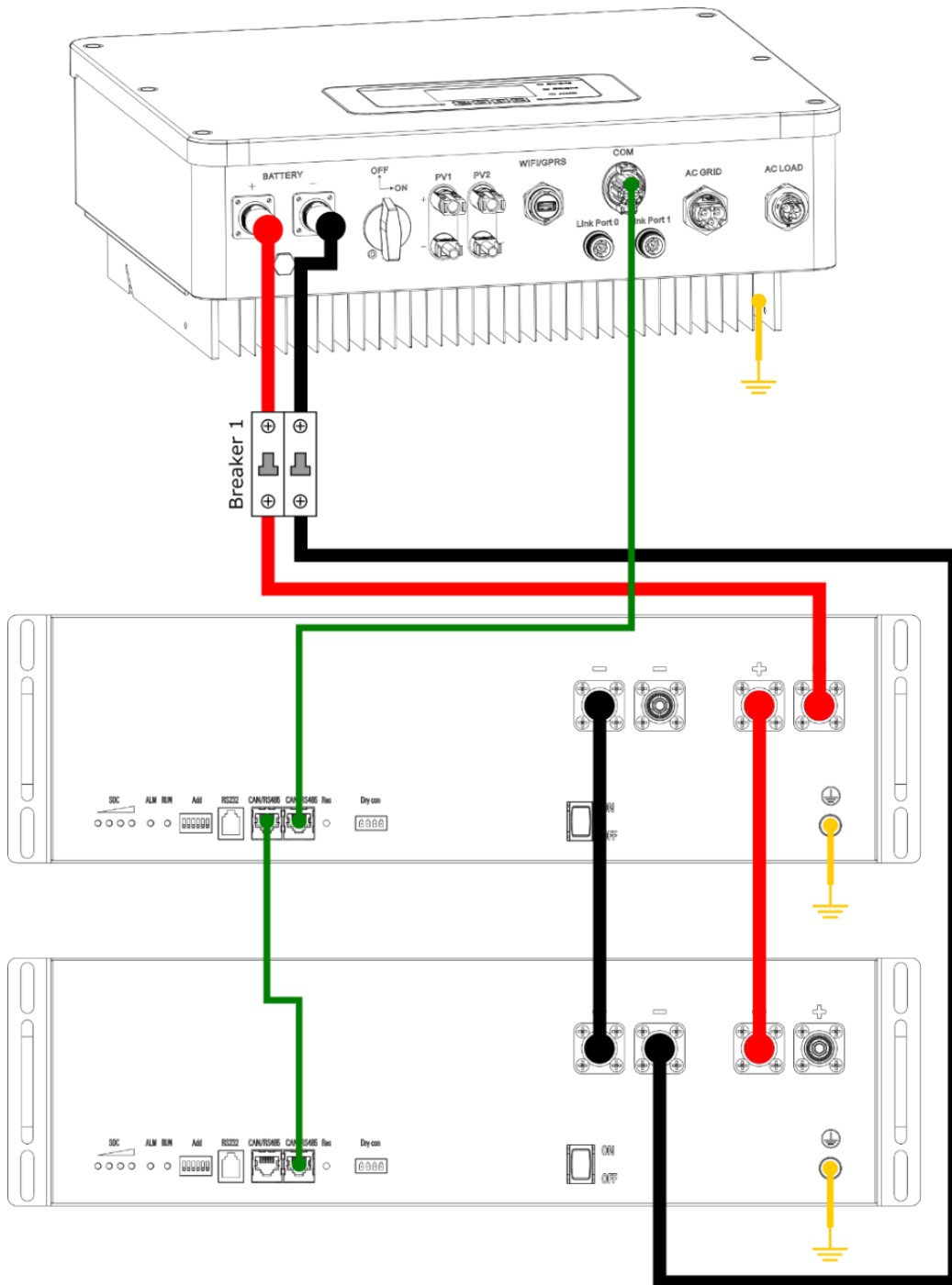

Example for 3 and more Batteries

Bus bar is required and a battery breaker per battery is needed.

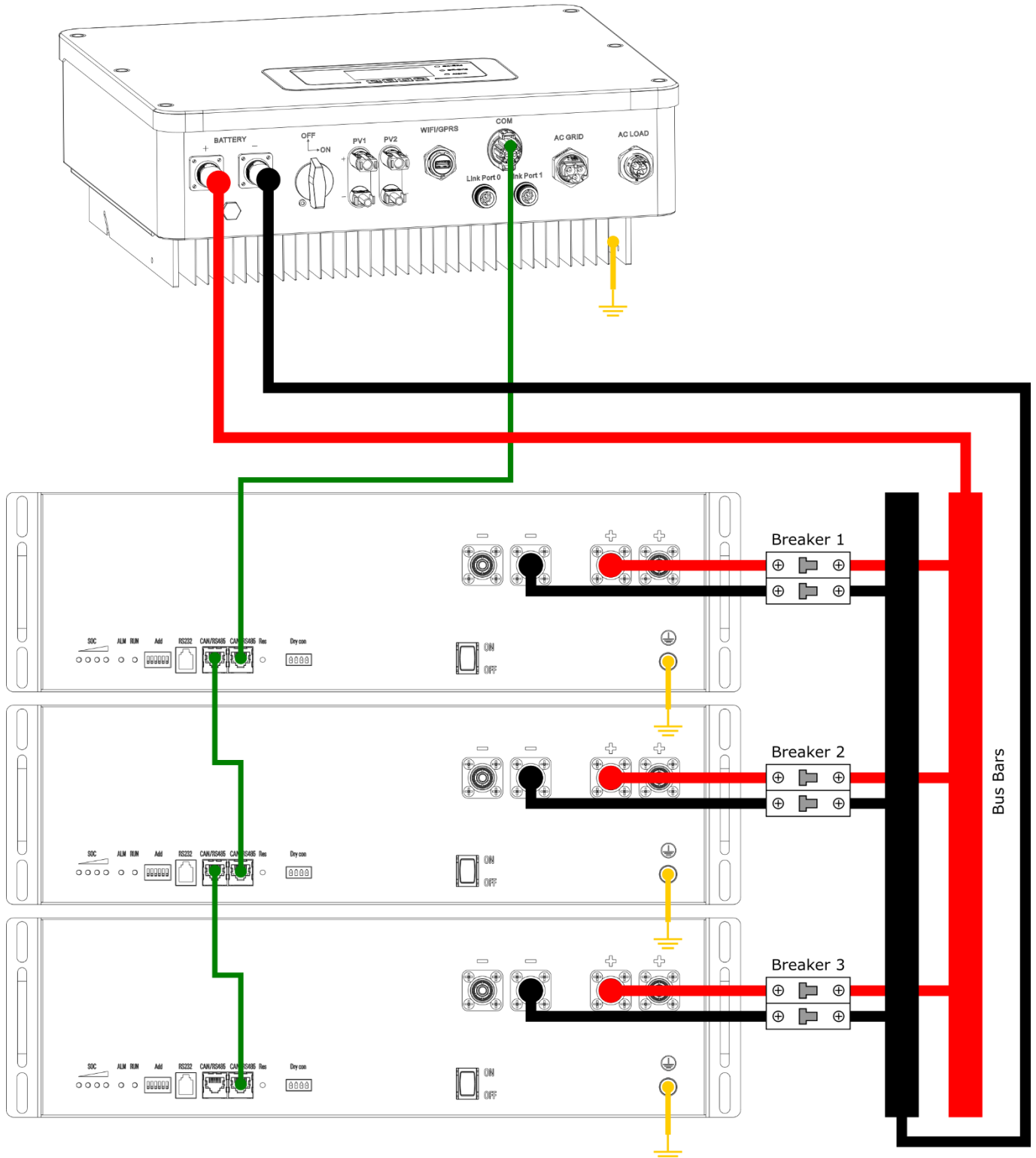



Sol-Ark

These examples apply to the following Sol-Ark inverters:

- 8K-P
- 12K-P

and show L051100-A Power Lite batteries. See [Battery Communication](#) for details regarding -A1, -B and -D Power Lite batteries.

CAN Communication Pinout

Sol-Ark inverters have the following relevant CAN pinout:

Pin	1	2	3	4	5	6	7	8
Function		GND		CAN-H	CAN-L			

See section [Battery Communication](#) for the corresponding pins on the battery.

Battery Quantities

The following quantities of batteries are recommended (see section [General Battery Quantities](#) for details), while of course more batteries can be used.

Inverter Model	AC Phases	AC Power Cont.	Power Lite Recommended Battery Qty.
Sol-Ark 8K	2	8,000 W	4
Sol-Ark 12K	2	9,000 W	4

Example for up to 2 Batteries

No bus bar required, and a single battery breaker is sufficient.

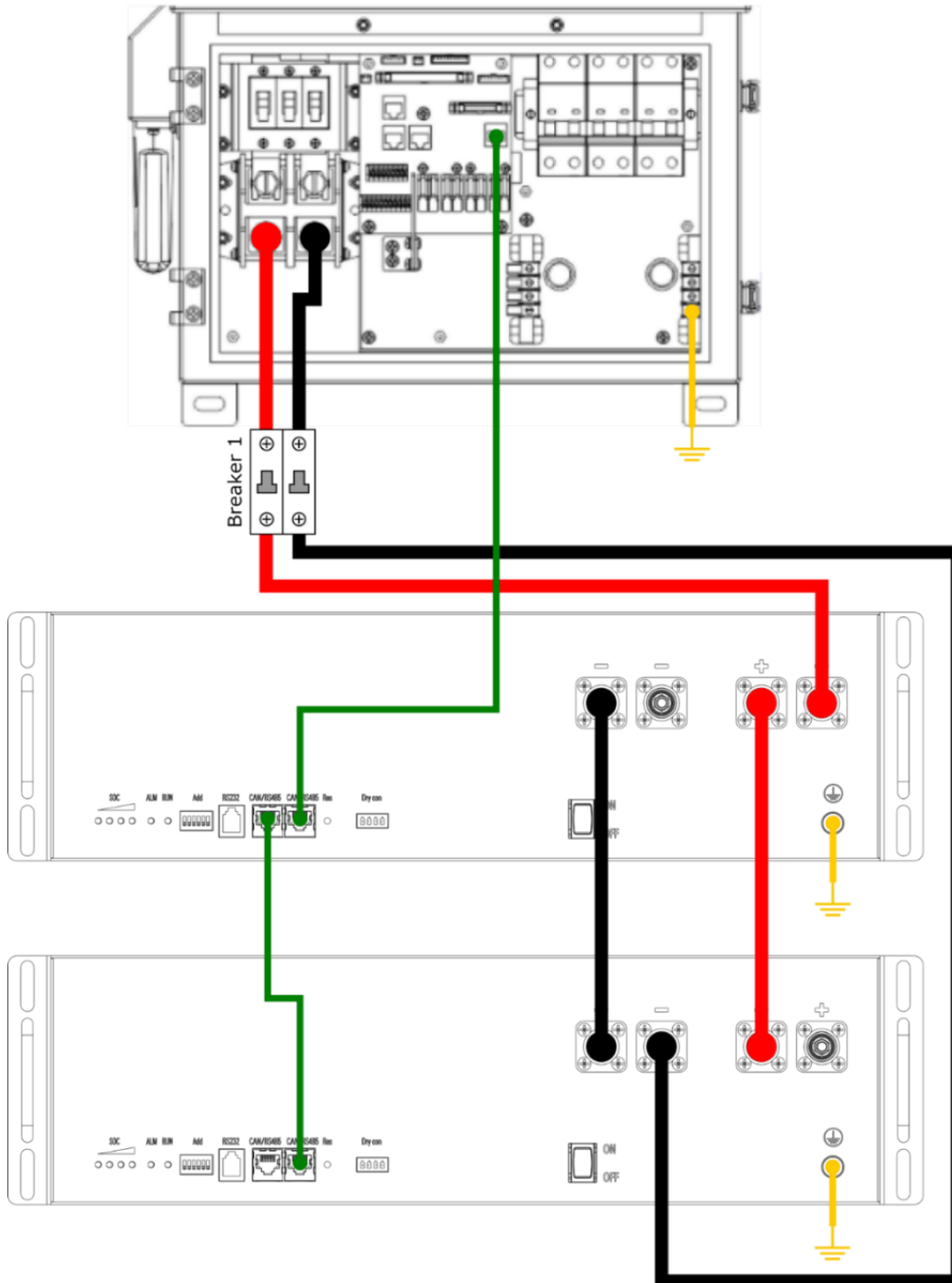

Example for 3 and more Batteries

Bus bar is required and a battery breaker per battery is needed.

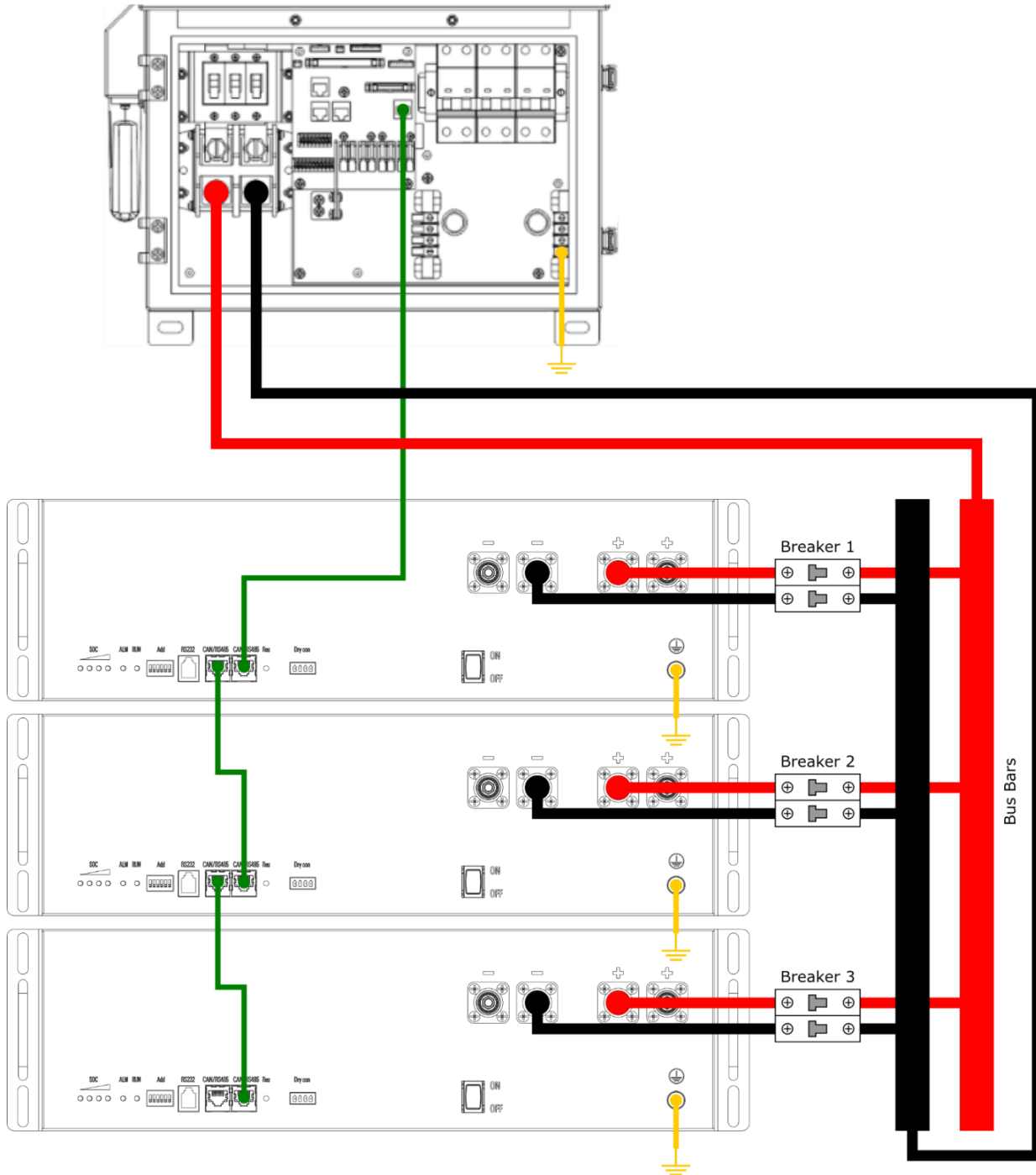

Solis

These examples apply to the following Solis inverters:

- RAI-3K series
- RHI-3-6K (5G) series
- S5-EH1P(3-6)K-L series

and show L051100-A Power Lite batteries. See [Battery Communication](#) for details regarding -A1, -B and -D Power Lite batteries.

Inverter Firmware Version

The minimum firmware requirement is:

- For inverter model: RAI-3K-48ES-5G
Firmware: B103A200, AcCou_3k_VA2_MF9.bin
HMI: V11
- For inverter model: Model: RHI-5K-48ES-5G
Firmware: 3300A2, CN_5G_5k_VA2_MF3.bin
HMI: V37
- For inverter model: RHI-6K-48ES-5G
Firmware: 33002A, CN_5G_6k_VA2_MF6.bin
HMI: V37
- For inverter model: S5-EH1P(3-6)K-L series
HMI: V37

Power Lite L051100-A Battery Firmware Version

Please check the firmware specifically for Solis inverters available at (see QR code):

<https://uzenergy.notion.site/BMS-Firmware-Updating-and-Upper-Machine-User-Guide-54e006f3accc4aa5a6125be1f7c34e73>



CAN Communication Pinout

Solis inverters have the following relevant CAN pinout:

Pin	1	2	3	4	5	6	7	8
Function		GND		CAN-H	CAN-L			

See section [Battery Communication](#) for the corresponding pins on the battery.



Battery Quantities

The following quantities of batteries are recommended (see section [General Battery Quantities](#) for details), while of course more batteries can be used.

Inverter Model	AC Phases	Max. Charge / Discharge Power	Max. Charge / Discharge Current Cont.	Power Lite Recommended Battery Qty.
RAI-3K-48ES-5G	1	3,000 W	62.5 A	2
RHI-3K-48ES(-5G) S5-EH1P3K-L	1	3,000 W	62.5 A	2
RHI-3.6K-48ES-5G S5-EH1P3.6K-L	1	3,000 W	62.5 A	2
RHI-4.6K-48ES-5G S5-EH1P4.6K-L	1	5,000 W	100 A	2
RHI-5K-48ES-5G S5-EH1P5K-L	1	5,000 W	100 A	2
RHI-6K-48ES-5G S5-EH1P6K-L	1	5,000 W	100 A	2

Example for up to 2 Batteries

No bus bar required, and a single battery breaker is sufficient.

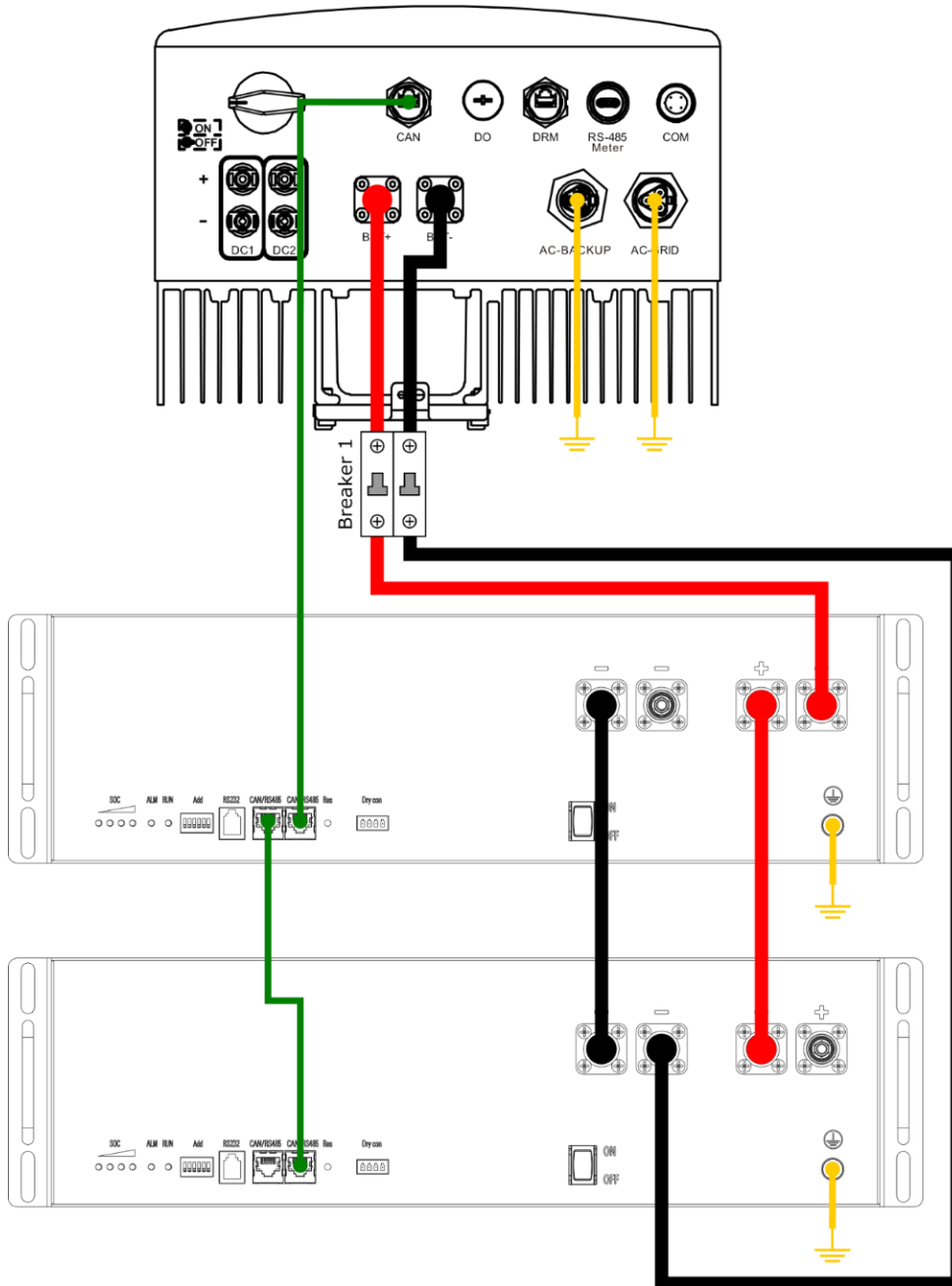

Example for 3 and more Batteries

Bus bars are normally required and a battery breaker per battery is recommended. However, because the listed Solis inverters up to 6 kW can source and sink a maximum of 100 A from and to the battery, a bus bar is not strictly needed for more than 2 batteries, if a single inverter is used. If not using a bus bar, refer to the previous example for up to 2 batteries above.

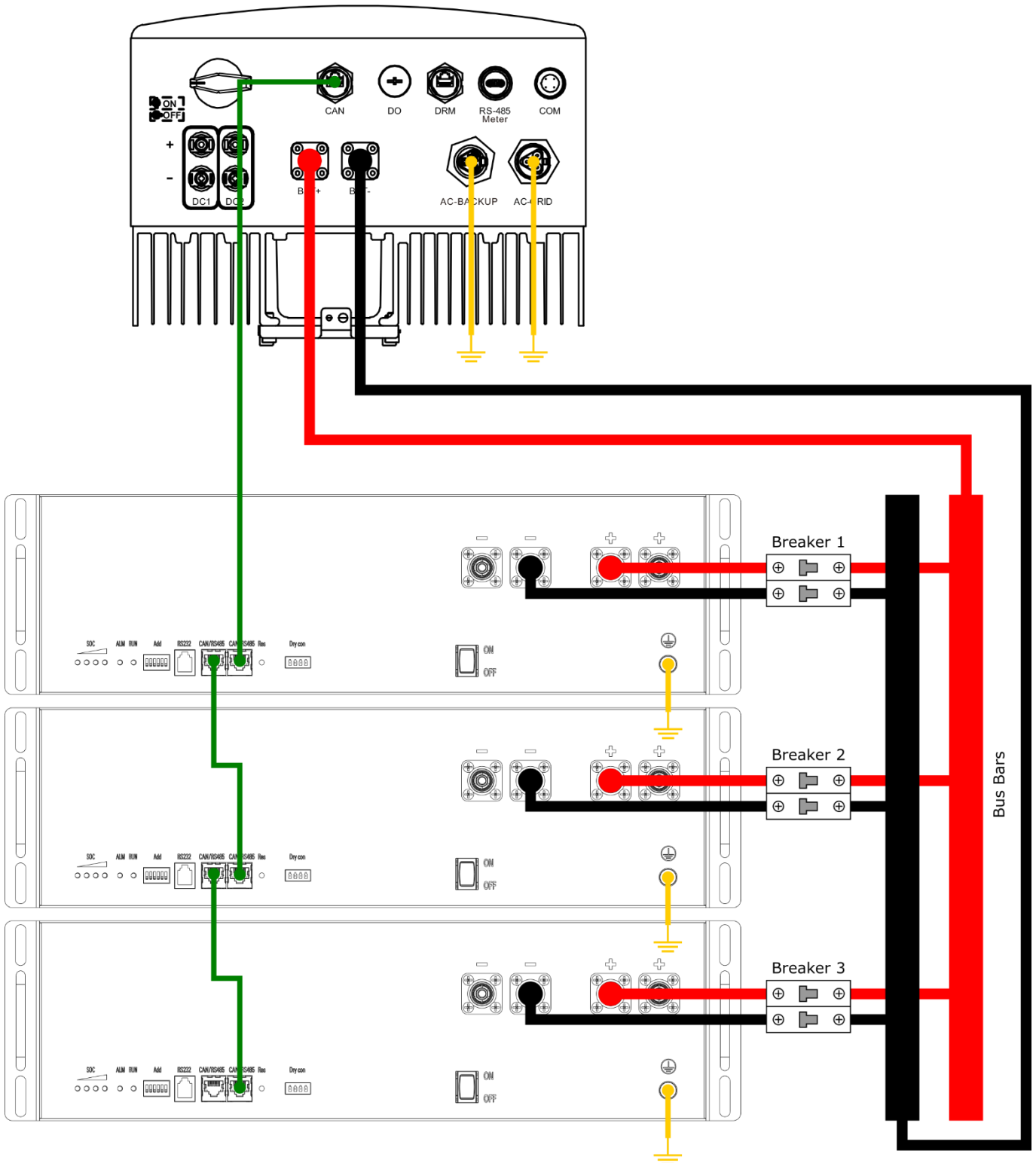



Steca (Open-Loop)

These examples apply to the following Steca inverters:

- PLI 5000-48

and show L051100-A Power Lite batteries. See [Battery Communication](#) for details regarding -A1, -B and -D Power Lite batteries.

Inverter Firmware Version

There is no minimum firmware requirement.

Communication

No communication is supported nor needed for Steca inverters.

Battery Quantities

The following quantities of batteries are recommended (see section [General Battery Quantities](#) for details), while of course more batteries can be used.

Inverter Model	AC Phases	AC Power Cont.	Power Lite Minimum Battery Quantity
PLI 5000-48	1	5,000 W	3

Example for up to 2 Batteries

No bus bar required, and a single battery breaker is sufficient.

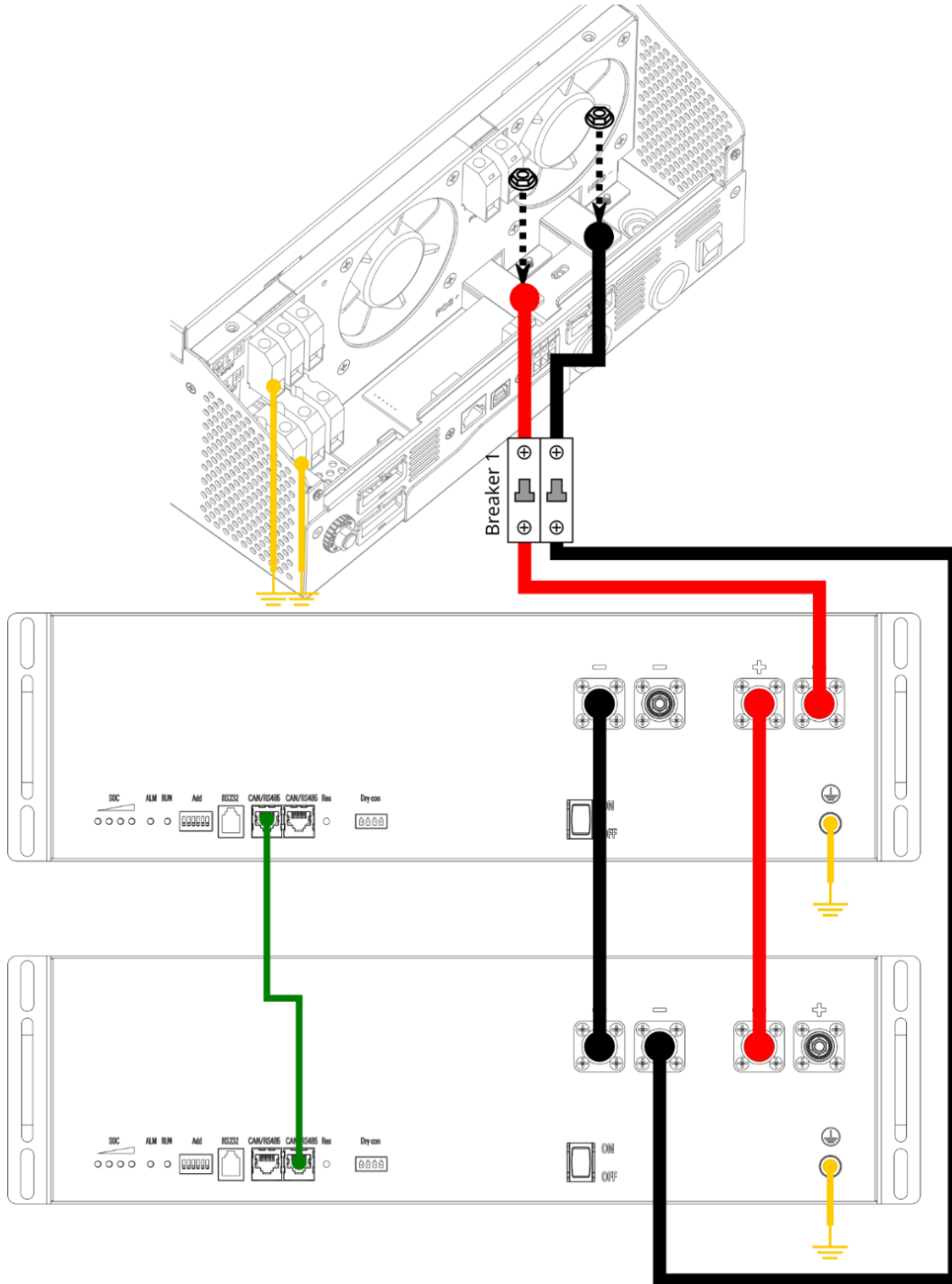

Example for 3 and more Batteries

Bus bar is required and a battery breaker per battery is needed.

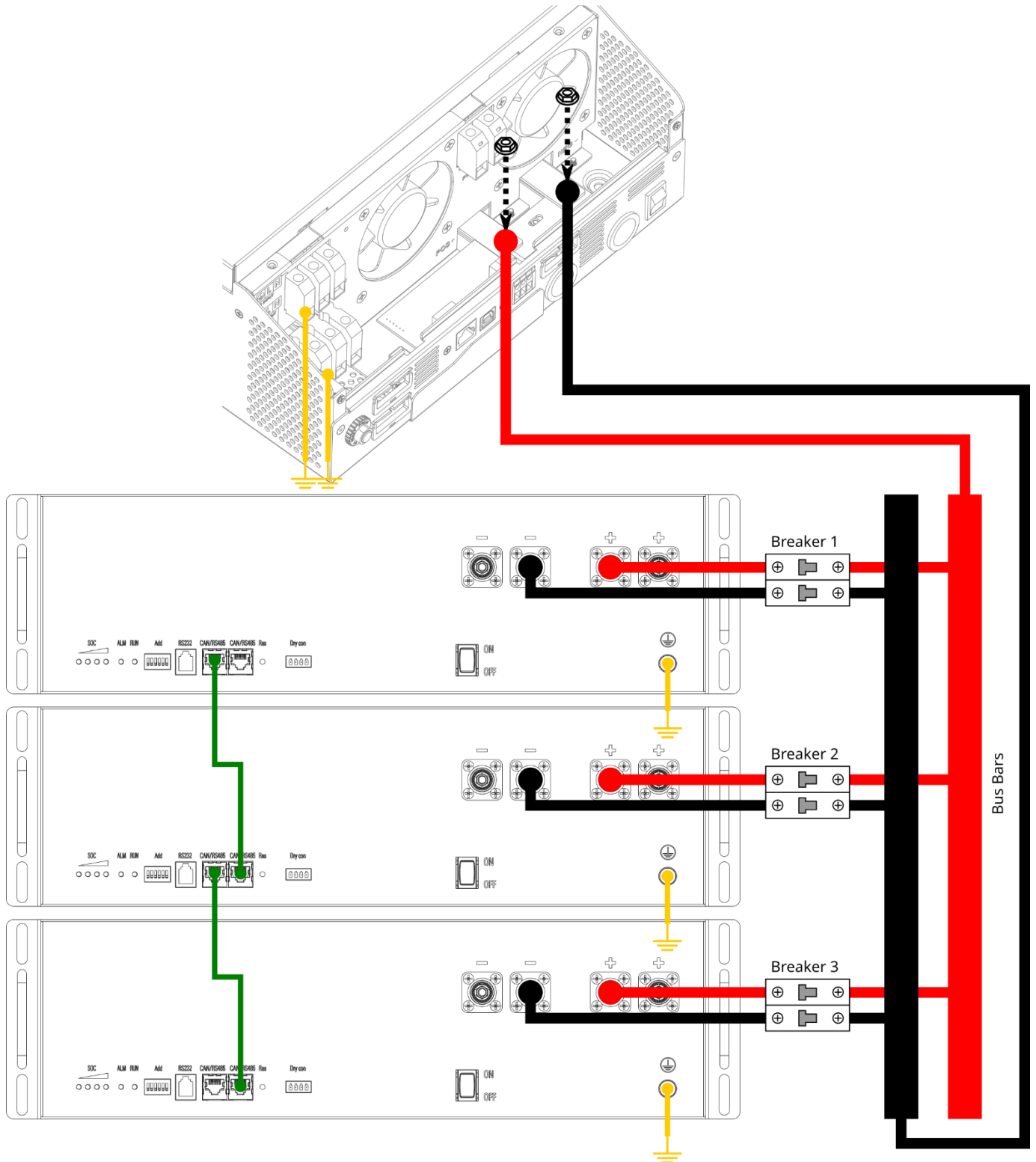



Voltronic Power (Open-Loop)

These examples apply to the following Voltronic inverters:

- All Axpert and InfiniSolar series inverters designed for 48 Vdc batteries

and show L051100-A Power Lite batteries. See [Battery Communication](#) for details regarding -A1, -B and -D Power Lite batteries.

Inverter Firmware Version

There is no minimum firmware requirement.

Communication

No communication is supported nor needed for Voltronic inverters in this open-loop configuration.

Battery Quantities

The following quantities of batteries are recommended (see section [General Battery Quantities](#) for details), while of course more batteries can be used.

Inverter Model	AC Phases	AC Power Cont.	Power Lite Recommended Battery Qty.
≤ 4000 W	1	≤ 4,000 W	2
5,000 ~ 7,000 W	1	5,000 ~ 7,000 W	3
> 7,000 W ~ 9,000 W	1	7,000 ~ 9000 W	4

Example for up to 2 Batteries

No bus bar required, and a single battery breaker is sufficient.

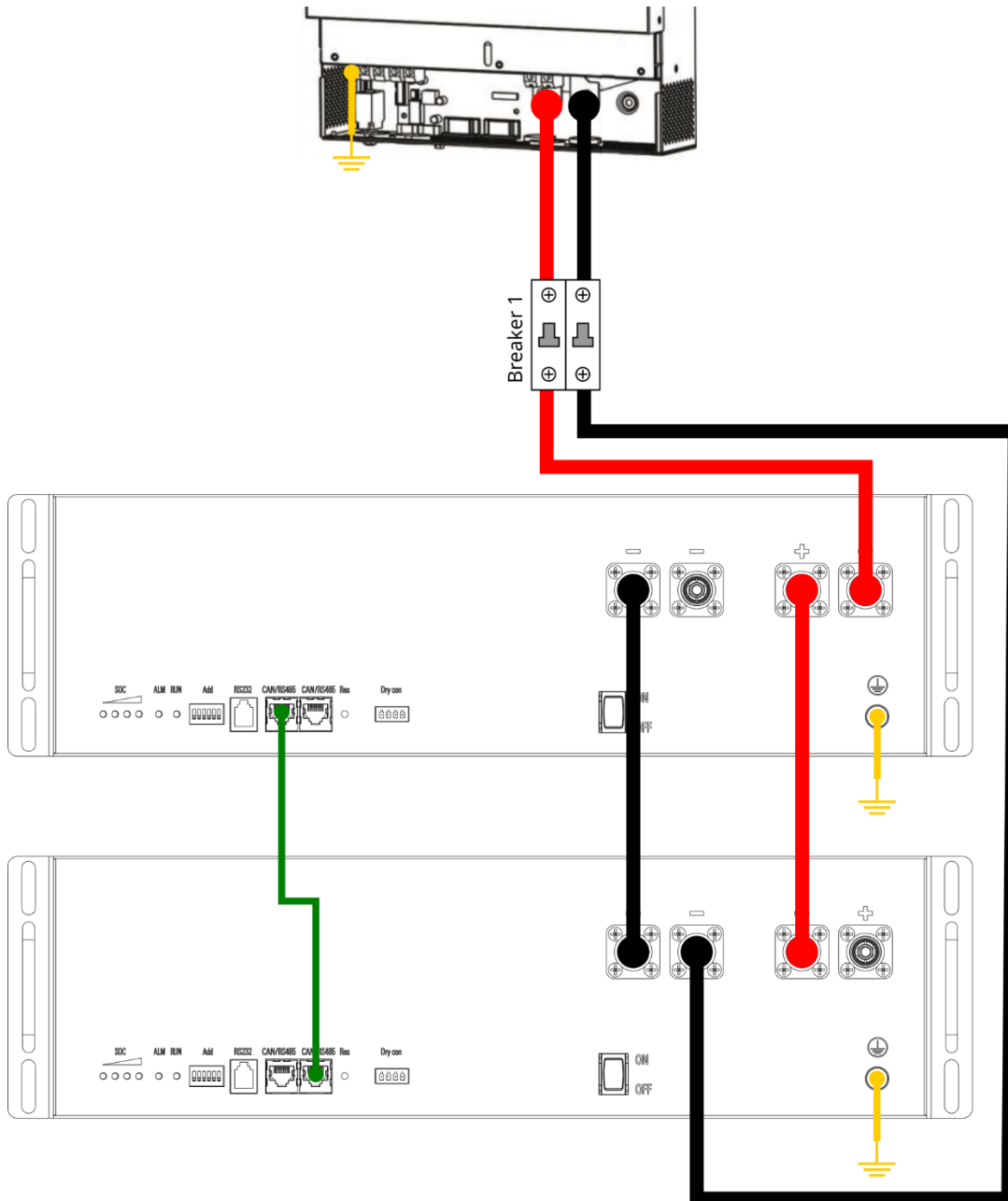

Example for 3 and more Batteries

Bus bar is required and a battery breaker per battery is needed.

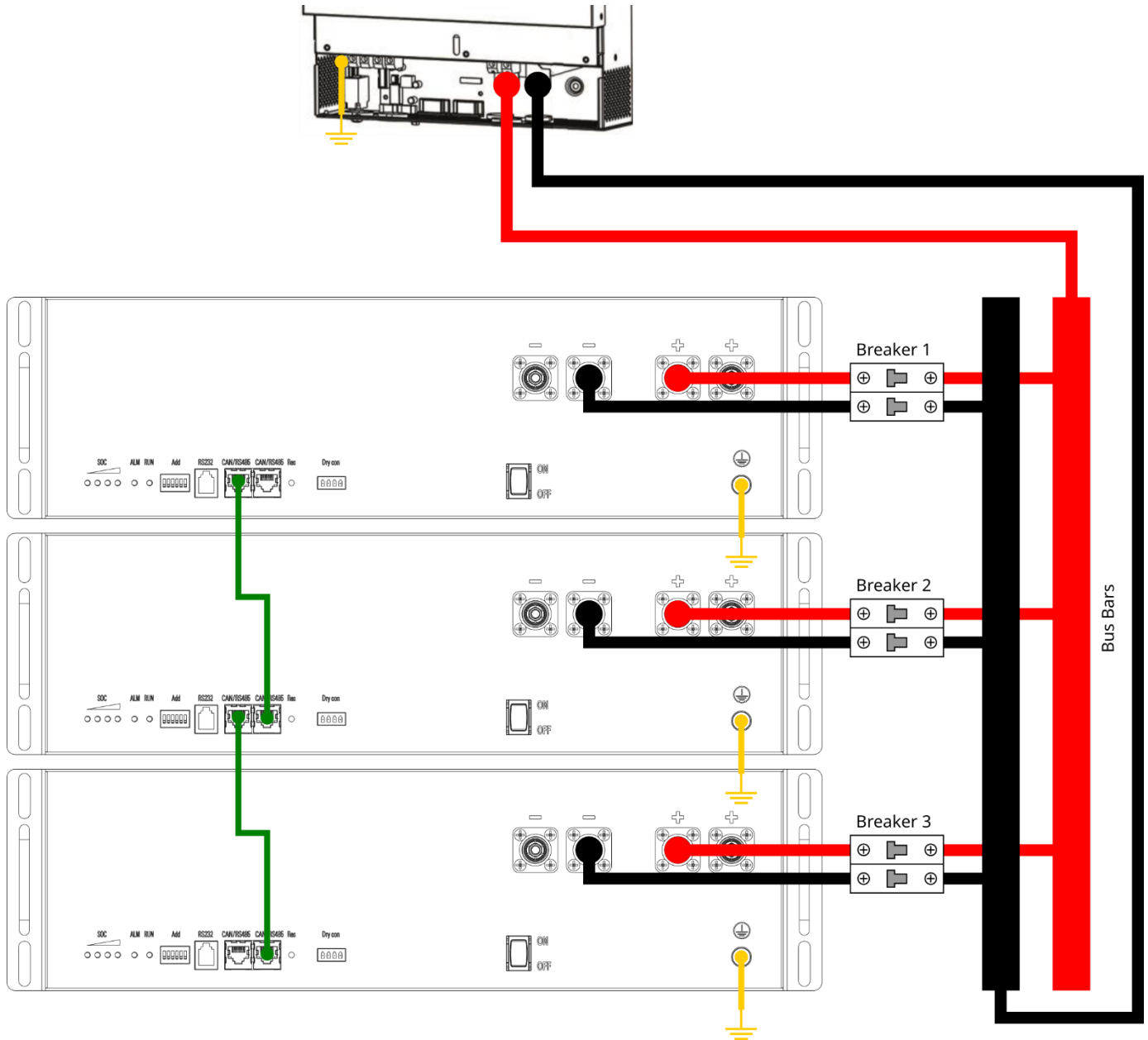



Voltronic Power (Closed-Loop)

These examples apply to the following Voltronic Power inverters (necessary inverter firmware may be pending completion at this time):

- Axpert King Rack 5K (48 Vdc)
- Axpert King 5K (48 Vdc)
- Axpert MAX (48 Vdc)
- Axpert VMIII (48 Vdc)
- Other Axpert inverters that have a CAN port

and show L051100-A1 Power Lite batteries in the example, but it also applies to -B and -D Power Lite batteries. When using -A Power Lite batteries, please use the methods in the section [Voltronic Power \(Open-Loop\)](#) instead.

Inverter Firmware Version

The minimum firmware requirement is:

- For inverter model: Axpert King Rack 5K
Firmware U1: 75.08
Firmware U2: 15.06
- Ensure that in the inverter settings menu 05 “CAN” is available as a battery type: **CAN**. Select this battery type once all wiring is completed.
If this battery type is not available in your inverter, closed-loop communication is not possible, please use the methods in the section [Voltronic Power \(Open-Loop\)](#) instead. Alternatively, check with your dealer to see if there is a firmware update for the inverter available enabling “CAN” as the battery type.

Power Lite L051100-A1 Battery Firmware Version

Please request the battery firmware specifically for Voltronic Power inverters from your dealer.

CAN Communication Pinout

Voltronic Power inverters have the following relevant CAN pinout:

Pin	1	2	3	4	5	6	7	8
Function						CAN-H	CAN-L	

See section [Battery Communication](#) for the corresponding pins on the battery.

For the cables between the batteries and the RJ45 8P8C hub (see [Example for 3 and more Batteries](#)), standard straight CAT5 ethernet patch cables can be used without modification.

Battery Quantities

The following quantities of batteries are recommended (see section [General Battery Quantities](#) for details), while of course more batteries can be used. As the Axpert King series cannot limit battery discharge current

and is designed for (partially) Off-Grid systems, we strongly recommend using at least the recommended battery quantity. Please find the recommended battery quantities in the section [Voltronic Power \(Open-Loop\)](#) → [Battery Quantities](#).

Example for 3 and more Batteries

Bus bar is required and a battery breaker per battery is needed.

