



ASCENT
Carport

Aluminium Waterproof Carport

**PORTRAIT CONCRETE
FOUNDATION**

Version 1

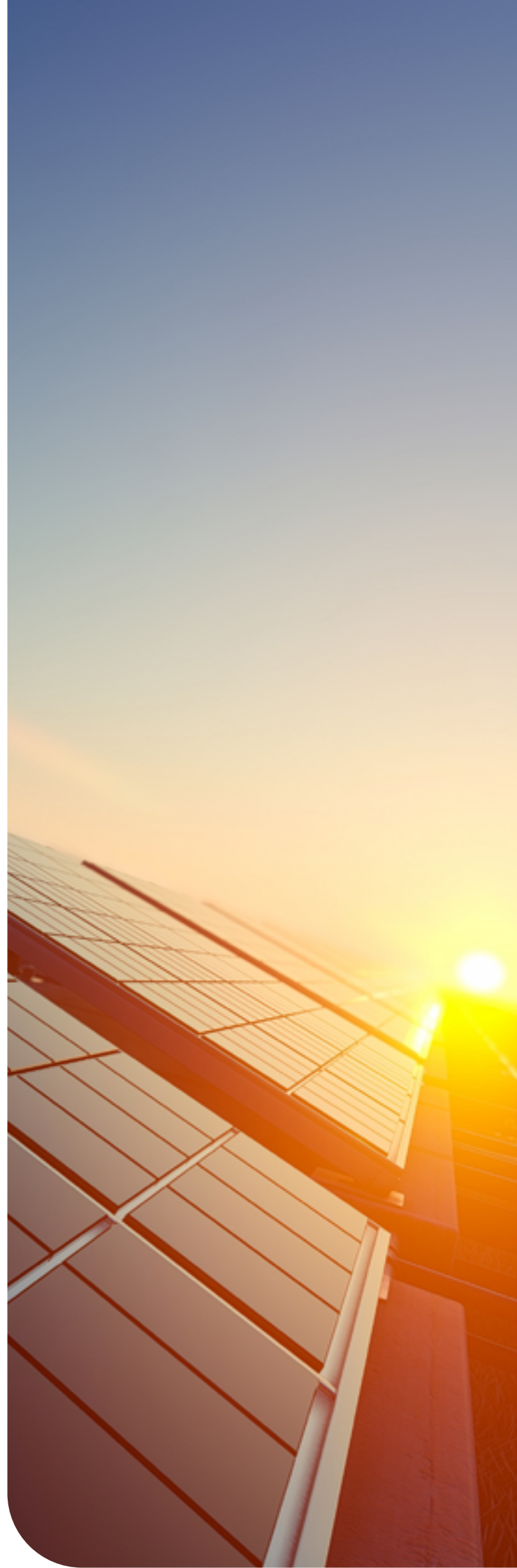

General information

ASCENT provides new, pre-assembled PV mounting systems, such as this aluminium ground mounting and carport system. The pre-assembled structure and unique beams not only guarantee the stability of the whole system, but also allows for faster and easier installation. The high-quality system requires few components - saving on installation time and costs.

Ascent products are:

- Easy to install
- Innovative and engineered to speed up installation time
- Backed by a 10-year warranty and AS/NZS1170.2.2011 AMDT 3 -2012 compliant

Applications:

- Ground mounting
- Residential and commercial use

Features:

- Extruded from anodised Al 6005-T6 (aluminium)
- Can be preassembled, making installation quick and easy
- Suitable for a variety of conditions and for use with current, popular PV panels
- Inherent corrosion resistance results in lower maintenance and extended product life
- 10-year limited warranty backed by the parent company (Antai Aluminium)

Material standard:

Material	Yield strength (MPa)	
	Tensile Strength	Yield Strength
Al 6005-T6	295	263

Product Information

This ASCENT product is a waterproof carport structure, ideal for mounting energy generation solutions on large surfaces that would otherwise go unused. Along with energy production, this solution brings maximum convenience by providing cool, shady and dry parking spaces all year around. This waterproof solar carport is suitable for a framed module installation.



Figure 2. ASCENT mounting structure for IBR roofing sheets



Product features

- Can withstand windy conditions of up to 42m/s
- Can be used with modules with dimensions: 2279 x 1134 x 35mm

Components

Part Name	ASCENT Part Number	Picture
ASCENT Carport End clamp 40mm M8x25	A5001010	
ASCENT Carport Mid clamp 40mm M8x30	A5001020	
ASCENT Carport NW rail 5000mm 1250mm	A5001030 A5001032	
ASCENT Carport GN rail 4500mm 2450mm	A5001040 A5001042	
ASCENT Carport NW Rail Splice	A5001050	
ASCENT Carport GN Rail Splice	A5001060	
ASCENT Carport Beam 4500mm 1900mm	A5001070 A5001072	
ASCENT Carport Leg Pole 2612mm 3007mm 3086mm 3492mm	A5001084 A5001085 A5001086 A5001087	

Part Name	ASCENT Part Number	Picture
ASCENT Carport Beam Connector	A5001090	
ASCENT Carport Bottom Rail Clamp	A5001100	
ASCENT Carport Cover Plate 4500mm 2450mm	A5001110 A5001112	
ASCENT Carport 35x6 EPDM Rubber String	A5001120	
ASCENT Carport Eyelet Anchor Bolt M16*300	A5001130	
ASCENT Carport Guiding Gutter Water Channel 968mm	A5001140	
ASCENT Carport Base	A5001160	
ASCENT Carport W Rail Clamp	A5001170	

Part Name	ASCENT Part Number	Picture
Ascent Carport M12x130mm Hex Bolt	A5001151	
ASCENT Carport Rail EPDM Rubber Rail Cap	A5001180 A5001181	
Rubicon Class 4 self tapper with seal	RUB-M3X25-HEX-CL4	

Installation Manual

Tools required for this installation:

6mm Inner Hexagon Spanner	Adjustable spanner	Box spanner (M12 / M16)
Marker	Torque Spanner	String
Level	Electric Drill	Measure tape

Installation Instructions

1. Prepare all necessary tools and products before installation.
2. Mark the positions of each of the concrete blocks as per the engineering drawings.

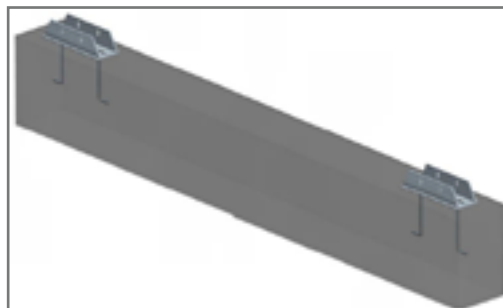

4. If the beam is too short, connect two beams (A5001070/A5001072) using the beam connector (A5001090).

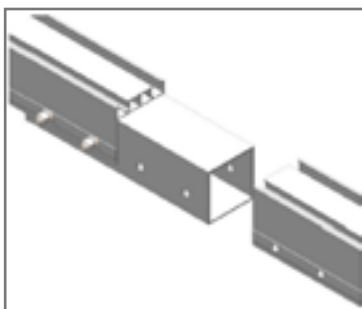

5. Attach the assembled beams (A5001070/A5001072) to the assembled legs (A5001084, A5001085, A5001086, A5001087).

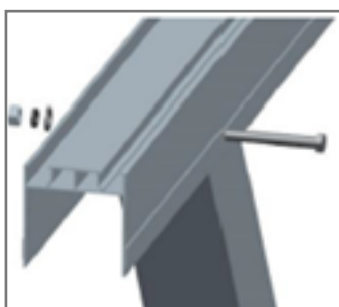

6. Connect the leg poles (A5001084, A5001085, A5001086, A5001087) to the base (A5001160) that is attached to the concrete.

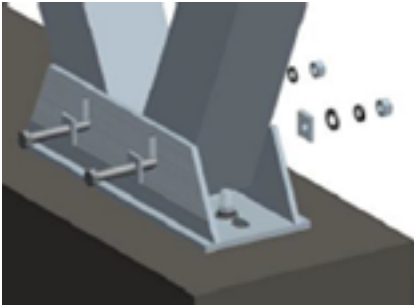

7. Repeat the above steps for all the concrete blocks and mounting structures making sure that the support structures are on the same plane.

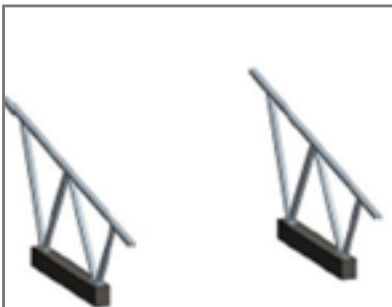

8. If the rails are too short, connect the rails (A5001030/A5001032) by inserting one rail into another and fix half of the rail splice (A5001050) into the one rail and the other half of the rail splice (A5001050) into the other rail. Fix in place.

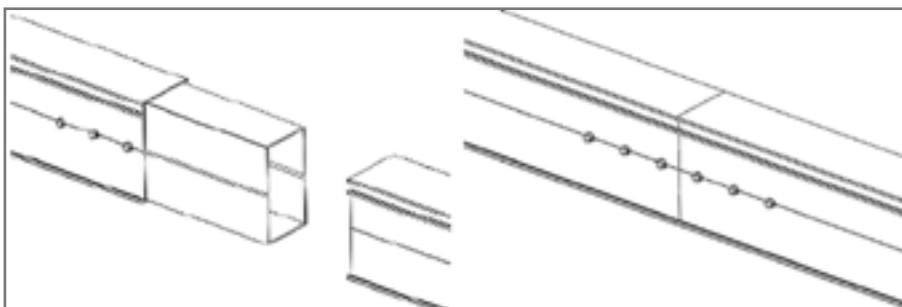

9. Fix the rails (A5001030/A5001032) to the beams (A5001070/A5001072) using 4 rail clamps (A5001100) – 2 clamps on each side.

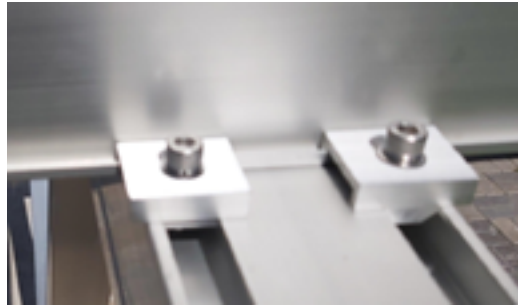
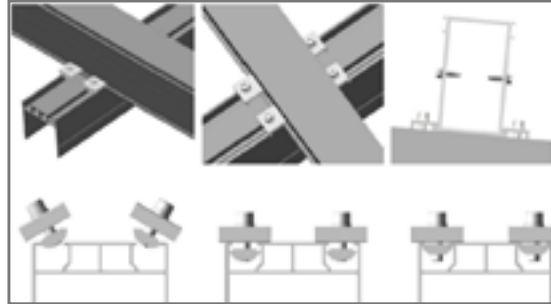

10. To install the water guiding rail, ensure that the W-shaped rail (A5001040/A5001042) is the correct length. If it is too short, insert 2 rail splices (A5001060) on the edge of each of the rails. Ensure that half the splice is on the end of each of the rails and fix in place with 2 screws on each side.

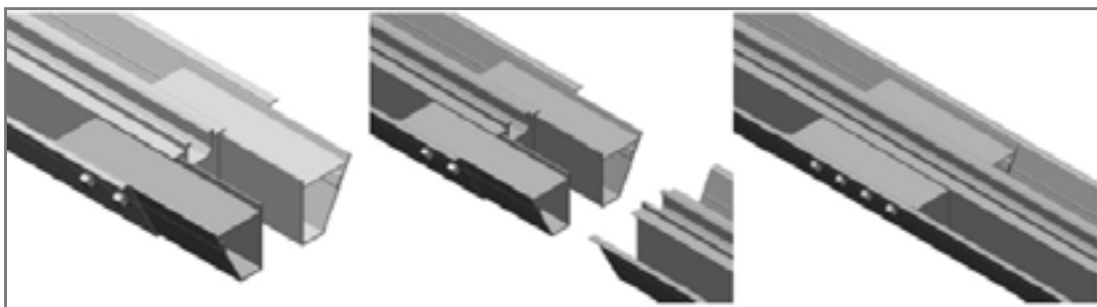

11. Seal the connection above with structural sealant.

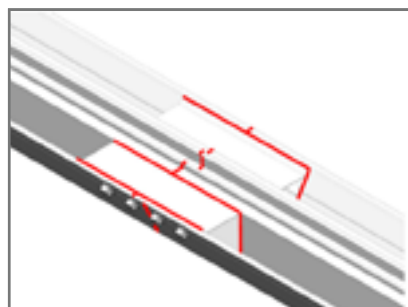

12. Fix the W-rail (A5001040/A5001042) to the bottom rail (A5001030/A5001032) using 2 rail clamps (A5001170), with one on each side.

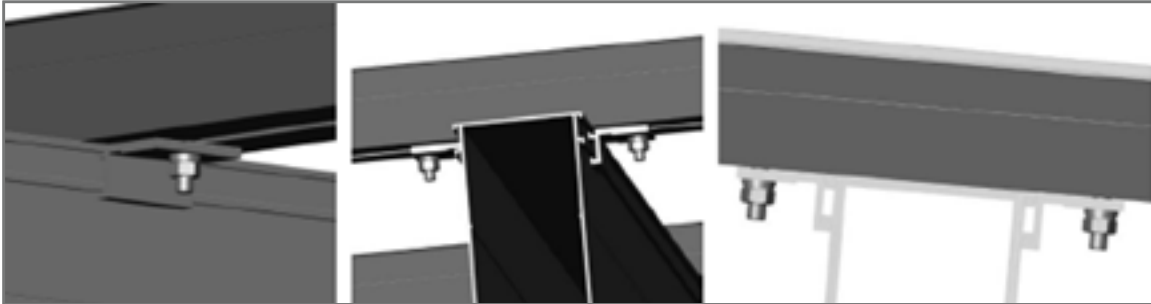

13. Place the horizontal water guiding channel (A5001140) on the W rails (A5001040/A5001042) between where the panels will be placed.

14. Place the panels on the W rails (A5001040/A5001042), ensuring that the water guiding channel (A5001140) is between each of the panels. Ensure that panel installation starts at the bottom.

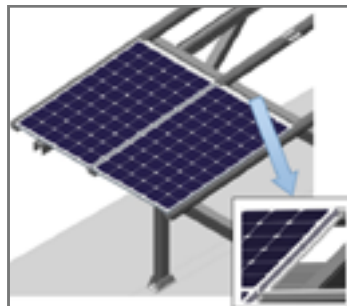

15. Use the clamps to fix the panels in place. The clamps fit above the panels and in the W rail (A5001040/A5001042). The end clamps (A5001010) are used on the edge panels and the mid clamps (A5001020) are used to fix the panels next to one another. Place the rubber string (A5001120) between the panels.

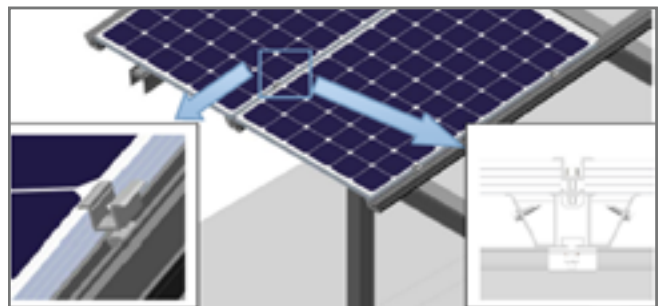
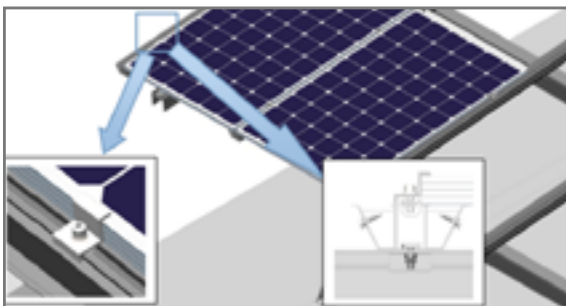

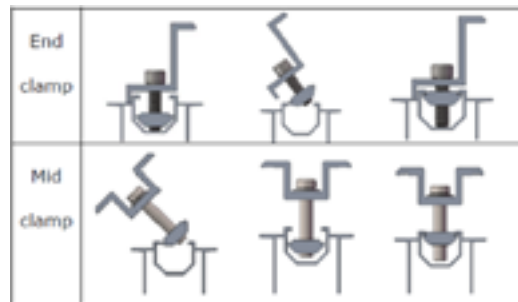

16. Place the top covers (A5001110/A5001112) on top of the mid clamps (A5001020) and press it into the W rail.



Installation Precautions

Dimensions:

The specific dimensions of the engineered installation will be subject to the engineering construction drawings. The installation manual is only for the instruction of the product installation.

Fastener:

If used inappropriately, nuts and bolts may lock-up. To avoid this:

- Reduce the friction coefficient by ensuring the thread is clean and using a lubricant during installation.
- Ensure that the fasteners are installed correctly, perpendicular to the axis of the screw thread. Apply even strength throughout tightening. Use torque or socket wrenches where possible.
- Do not tighten fasteners at high temperatures or with electric equipment resulting in a rapid rise in temperature.

Appendix





