



the ORIGINAL all NATURAL™

20-Quart Pressure Canner *And Pressure Cooker/Steamer*



Instruction Manual and User Guide

TABLE OF CONTENTS

| | |
|--|----|
| 1. Important Safeguards..... | 3 |
| 2. Your New Pressure Canner..... | 4 |
| 3. Component Part Descriptions | 5 |
| 4. Replacement Parts..... | 7 |
| 5. Before Using Your New Pressure Canner..... | 8 |
| 6. Pressure Canning General Information..... | 8 |
| 7. Canning at Altitude: Adjustment Guide..... | 9 |
| 8. Using Your Pressure Canner..... | 10 |
| 9. Cleaning and Maintenance..... | 15 |
| 10. Model Number & Company Information..... | 15 |
| 11. Replacement Part Guide..... | 16 |
| 12. USDA Food Classifications & Cooking Times..... | 17 |
| 13. Additional Recipe and Information Resources..... | 20 |

This Granite·Ware® product is a  listed appliance. The following Important Safeguards are recommended.

IMPORTANT SAFEGUARDS

When using pressure cookers, basic safety precautions should always be followed:

1. Read all instructions.
2. Do not touch hot surfaces. Use handles or knobs.
3. Close supervision is necessary when the pressure cooker is used near children.
4. Do not place the pressure cooker in a heated oven.
5. Extreme caution must be used when moving a pressure cooker containing hot liquids.
6. Do not use pressure cooker for other than intended use.
7. This appliance cooks under pressure. Improper use may result in scalding injury. Make certain unit is properly closed before operating. See “Using Your Pressure Canner, pages 10-14.”
8. Do not fill the unit over 2/3 full. When cooking foods that expand during cooking such as rice or dried vegetables, do not fill the unit over 1/2 full. Over filling may cause a risk of clogging the vent pipe and developing excess pressure. See “USDA Food Classifications and Recommended Cooking Times, pages 17-19.”
9. Be aware that certain foods, such as applesauce, cranberries, pearl barley, oatmeal or other cereals, split peas, noodles, macaroni, rhubarb, or spaghetti can foam, froth, and sputter, and clog the pressure release device (steam vent). These foods should not be cooked in a pressure cooker.
10. Always check the pressure release devices for clogging before use.
11. Do not open the pressure cooker until the unit has cooled and all internal pressure has been released. If the handles are difficult to push apart, this indicates that the cooker is still pressurized – do not force it open. Any pressure in the cooker can be a hazardous. See “Using Your Pressure Canner, pages 10-14.”
12. Do not use pressure cooker for pressure frying with oil.
13. When the normal operating pressure is reached, turn the heat down so all the liquid, which creates the steam, does not evaporate.
14. **SAVE THESE INSTRUCTIONS.**

YOUR NEW PRESSURE CANNER

This Granite·Ware® canner/cooker/steamer is a large capacity pressure vessel designed for home canning your favorite fruits, vegetables, meats and poultry. Because of its hard anodized finish – a high-end cookware feature – the canner can also be used as a pressure cooker and steamer with outstanding results and no adverse affects on the taste or color of your food.

The canner achieves the high temperatures required for safely processing foods through heated water which produces steam and pressure inside the canner. The United States Department of Agriculture (USDA) endorses the pressure canner as the only safe method canning meats, poultry and low-acid vegetables.

Pressure cooking is fast, healthy and cost-effective. This Granite·Ware® pressure cooker preserves flavor and nutrients, tenderizes tough cuts of meat, and cooks many foods in one-third to one-tenth the time compared to traditional methods, and it is large enough to create family-sized meals with ease.

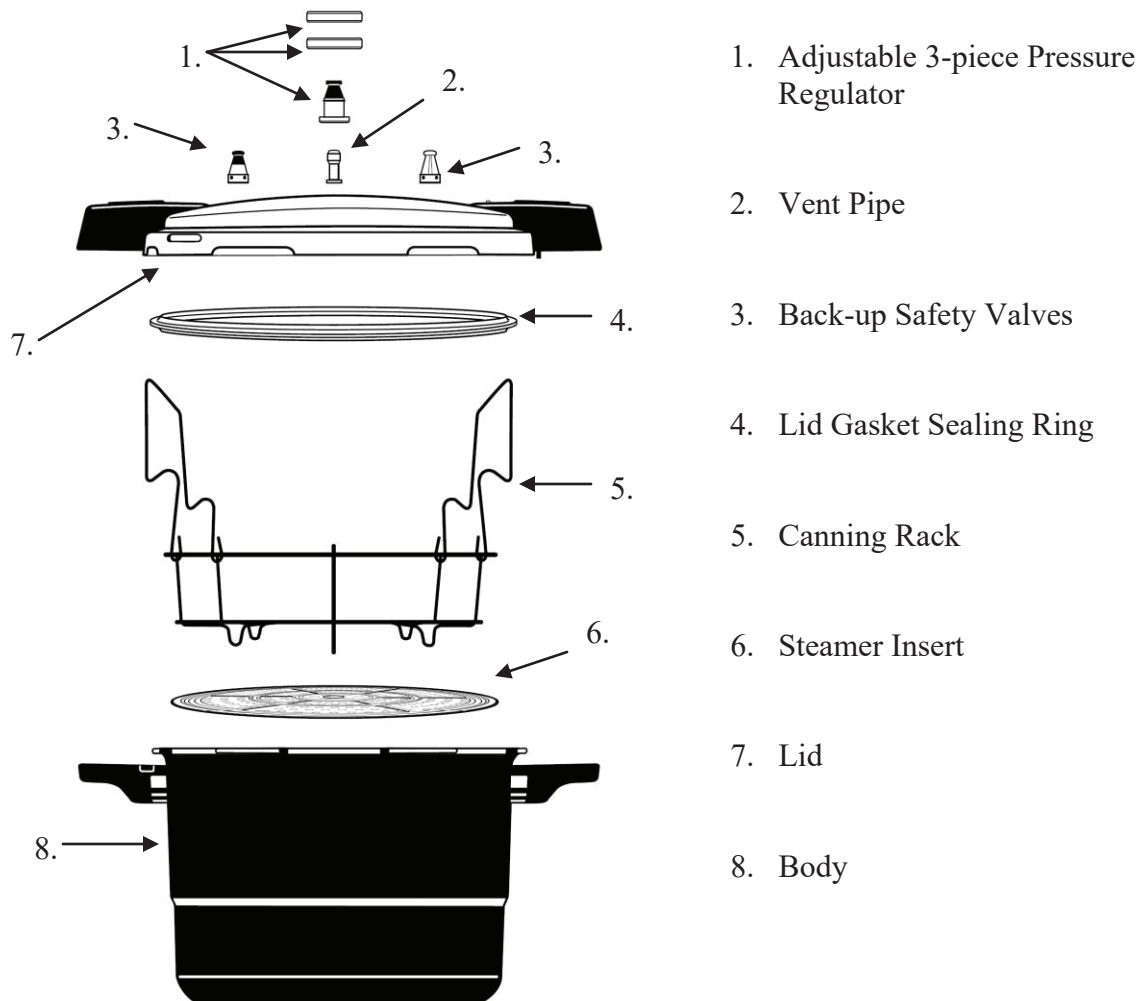

1. ADJUSTABLE 3-PIECE PRESSURE REGULATOR

The Pressure Regulator controls the pressure inside the canner. When normal operating pressure is reached, the pressure regulator will begin to rock. Gradually lower the heat as necessary to maintain the pressure. Correct pressure is indicated by a consistent gentle rocking of the pressure regulator. It is normal for some steam to be release when the proper pressure is attained.

The Pressure Regulator is calibrated for three different pressure levels measured in pounds per square inch or psi (5 psi, 10 psi, or 15 psi). The Pressure Regulator maintains 15 psi of pressure when completely assembled with the two additional weighted rings included.

For different pressure levels (See Canning at Altitude, page 9), the regulator can be adjusted by removing the appropriate number of weighted rings. With both rings removed, the regulator by itself maintains 5 psi. If 10 psi is required, add one ring to the regulator. If 15 psi is required, add both rings to the regulator.

5 psi Pressure Regulator 10 psi Pressure Regulator 15 psi Pressure Regulator

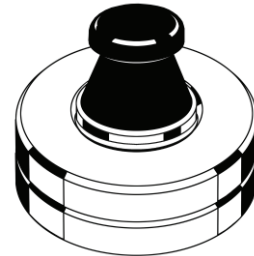
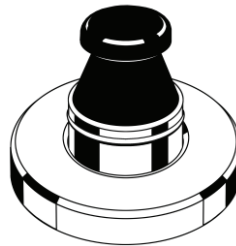
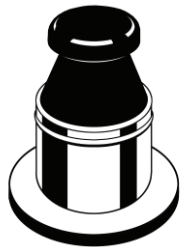

2. VENT PIPE

The vent pipe is located in the center of the lid. Steam will pass through the vent pipe to the Pressure Regulator. It is extremely important to keep the vent pipe clean and unobstructed. The Pressure Regulator sits loosely on the vent pipe. Push the Pressure Regulator downwards on the vent pipe until it clicks into place. The Pressure Regulator will move around when in place but is secured from lifting off by the safety catch. To remove the Pressure Regulator from the vent pipe, hold the regulator by the black top and pull directly upwards firmly until it passes over the safety catch. **NOTE: Do not remove the Pressure Regulator while pressure is in the vessel.**

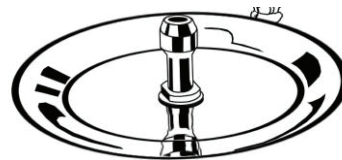

3. BACK-UP SAFETY VALVES

Two (2) additional safety valves are found on the top of the lid. One black cap safety valve is set to go off as back-up pressure release if the main pressure regulator fails or is clogged. The second safety valve is all metal and will exhaust residual pressure while sounding a whistling alarm.

The valves can be removed for cleaning and inspection by loosening their nut on the underside of the lid. Turn the nut counterclockwise (left) to loosen and remove the valves. Be sure to replace the valves and tighten the attachment nut by turning it clockwise (right) until secure.

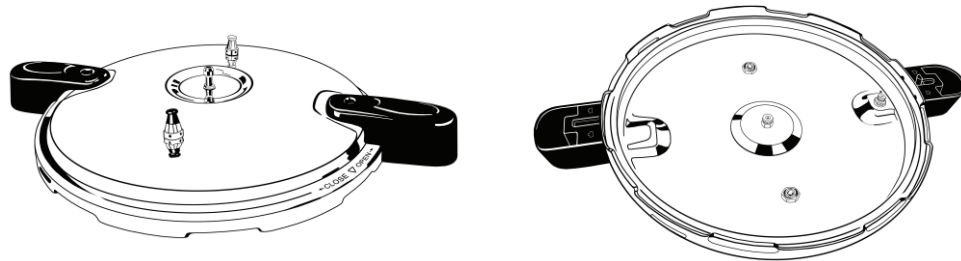

4. LID GASKET SEALING RING

The lid gasket is a flexible silicone ring that fits inside the canner cover and forms a pressure-tight seal between the body of the canner and the cover during use. Remove the gasket sealing ring before each use and inspect it for signs of wear and rigidity. The ring should bend easily and be free from holes or tears. Periodic light oiling with mineral oil will keep the ring flexible. We recommend replacing the lid sealing ring each canning season.



5. CANNING RACK

The canning rack holds jars off the bottom of the pot. Never place glass jars directly into the canner without the rack. The rack holds 7 quart jars, 8 pint jars or 24 half-pint jars. Lower the rack into the canner when ready to process your food. Fold handles inward so they do not touch the canner lid.

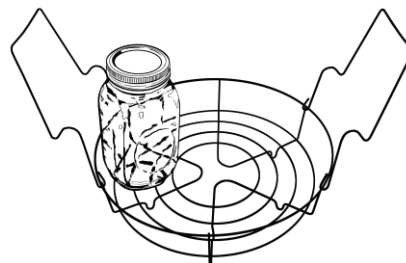

6. STEAMER INSERT

The steamer insert fits into the stepped portion of the canner about 2 inches from the bottom of the pot. Use the steamer insert to hold canning jars and foods out of the cooking liquid. The Granite·Ware® canner/cooker/steamer can handle all your large capacity steaming needs – for tamales, seafood, pulled pork, pot roast, ribs and more.

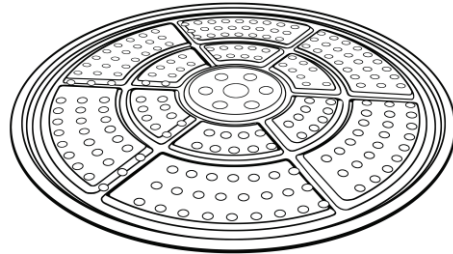

REPLACEMENT PARTS

Only use genuine Granite·Ware® replacement parts for your model canner. Replacement parts are available from the following authorized re-sellers. When ordering parts, please specify the model number of your canner and the part number as listed in the parts guide on page 16. The model number can be found on the bottom stamp of the canner just above the capacity designation.

<http://www.columbianhp.com> (812) 238-5000
<http://www.pressurecooker-outlet.com> (800) 251-8824



BEFORE USING YOUR NEW PRESSURE CANNER

1. Pull the lid gasket sealing ring out from the underside of the lid. The sealing ring will come out easily from the lid groove.
2. Wash the pressure canner body, lid and sealing ring in hot soapy water to remove any excess manufacturing residue. Rinse all parts with clear warm water and towel dry.
3. The lid gasket sealing ring comes pre-lubricated. A light coating of cooking oil or food-grade mineral oil may be applied to the sealing ring and the underside of the canner body lugs if desired, to help make the cover easier to open and close.
4. Put the lid gasket sealing ring back inside the lid, making sure to tuck it securely inside the lid groove and up against the inside edge of the lid all the way around. The ring should fit under the bent sections of the lid rim.

PRESSURE CANNING GENERAL INFORMATION

Foods for canning are classified into two types: high-acid foods and low-acid foods. Before you start canning, you need to determine the acid level of the food. Each type of food requires a different method of heat processing to achieve the required temperatures necessary to prevent the growth of harmful bacteria.

- High-acid foods include those with a pH of less than 4.6, such as fruit, pickles, sauerkraut, jams, jellies, marmalades and fruit butters.
- Low-acid foods include those with a pH of more than 4.6, such as meat, seafood, poultry, soup, milk and most fresh vegetables, except tomatoes. Tomatoes are borderline high-acid food and require an acid, such as lemon juice or vinegar, to be added for safer canning.

The United States Department of Agriculture (USDA) recommends the pressure canner as the only safe method for canning low-acid foods – generally, vegetables, meats, poultry, seafood or a combination of low-acid and high-acid foods. Pressure canners use steam under high pressure to ensure low-acid food reaches the high temperatures necessary to eliminate the bacteria that causes botulism.

Molds, yeast and enzymes are part of the natural spoilage cycle of fresh foods and can be destroyed at or near the temperature at which water boils (except in higher altitudes, see Canning at Altitude, page 9). Water-bath or boiling water canning is effective and sufficient to destroy these microorganisms. Using boiling water canners for low-acid foods, however, poses a real risk of botulism poisoning.

Botulism is caused by a poisonous toxin released from the spore of the *Clostridium Botulinum* bacteria. The spore of the *C. botulinum* bacteria is not destroyed at boiling water temperature, and the bacteria actually thrive on low-acid foods in the absence of air (anaerobic) conditions. All low-acid foods must be processed in a pressure canner to ensure safety. The time needed to destroy bacteria in low-acid canned food ranges from 20 to 160

minutes. The exact time depends on the type of food, the way it is packed into jars, and the jar size. We suggest you always follow the most recent USDA recommendations. The National Center for Home Food Preservation has a complete listing of current USDA recommendations at http://nchfp.uga.edu/publications/publications_usda.html

During pressure canning, water in the canner is converted to steam, which creates pressure within the canner. As pressure increases, so does temperature at this scale:

| | | | |
|----------------|----------------|----------------|----------------|
| 0 psi | 5 psi | 10 psi | 15 psi |
| 212° F (100°C) | 220° F (104°C) | 235° F (113°C) | 250° F (121°C) |

To get the temperature required to kill harmful bacteria, steam under pressure needs to be created. After the canning process when the jars cool, a vacuum is created sealing the food inside and preventing any new microorganisms from entering and spoiling the food.

If using store bought canned foods in your food preserving process, boil all low-acid foods including tomatoes for 10 minutes at altitudes below 1,000 feet. Extend the boiling time by 1 minute for each 1,000 foot increase in altitude. This is a good safeguard against spoilage not easily detected in canned goods.

CANNING AT ALTITUDE: ADJUSTMENT GUIDE

If canning above 1,000 feet in altitude, adjustments must be made to either the processing time or the canning pressure to ensure food safety. Using process time for canning food at sea level may result in spoilage if you live at altitudes of 1,000 feet or more. Water boils at lower temperatures as altitude increases. Lower boiling temperatures are less effective for killing bacteria. Increasing the process time or the canner pressure compensates for lower boiling temperatures. Therefore, you must select the proper processing time or canner pressure for the altitude where you live. There are numerous online websites available to help you determine the elevation at your location

Pressure canners need an additional 1/2 pound pressure for each 1,000 feet elevation above sea level according the USDA. Water-bath canning requires 2 additional minutes processing time for each 1,000 feet above sea level.

At different elevations, pressure canning processing time stays the same, only the weighted psi required changes.

| Altitude Adjustment for Pressure Canner | |
|---|--------------------------------|
| Altitude in Feet | Pounds Weighted Pressure (psi) |
| 0 – 1,000 | 10 |
| Over 1,000 | 15 |

USING YOUR PRESSURE CANNER

IMPORTANT: Read and save these instructions. Do not attempt to use your canner before reading and understanding these instructions.

Follow these pressure canning step-by-step instructions when using this canner. Always follow recipe directions and prepare food according to the specific directions in the recipe.

1. Before each canning session, be sure the canner is clean and in proper working order. Check the lid gasket sealing ring, the adjustable 3-piece pressure regulator, the back-up safety valves and all their attachment gaskets. Replace these parts when they become hard, deformed, worn out or unusually soft.

Some glass stovetops may not produce enough heat/energy required for safe pressure canning. We suggest you do not use on a glass stovetop.

2. Jars should be free from nicks, cracks and sharp edges. Lids and bands should be rust-free and not dented or deformed in any way. Use only jars, lids and bands in perfect condition to ensure an airtight seal.
3. Use only fresh, firm food. Sort by size and type, and clean food thoroughly. Always prepare food according to recipe. Always prepare foods by the recipe, pay close attention to the times and temperatures specified. Fill sterilized jars with food and liquid as described in recipe. Allow 1/2 inch headspace for fruits, and 1 inch headspace for vegetables and meats (to allow for expansion during processing).

Remove air bubbles with a Granite·Ware® Bubble Remover and Ruler by craping the inside edges and corners of the jar with the soft silicone spatula end. Use the ruler guide handle to accurately measure the desired headspace. Wipe the jar rim and sealing edges with a clean damp cloth. Place the lids on the jars and adjust the lid bands according to the closure manufacturer's directions.

4. Place 2 quarts of hot water into the canner. The 2-quart line is also where the insert trivet rests inside the canner. There is an internal ledge that holds the trivet in place. Set the steaer trivet securely in place, then add canning jars. Rotate jars slightly to reliee any tightness or pressure between jars. Always place jars on steaming trivet. Jars may break if set directly on the bottom of the canner.

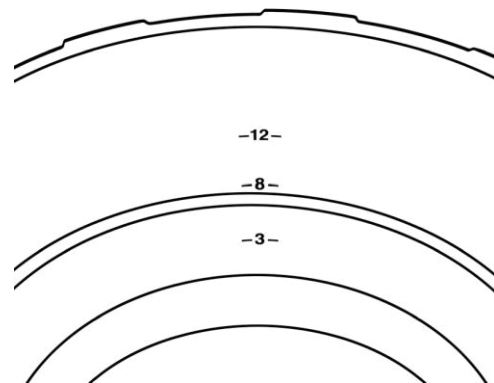

5. With the Pressure Regulator

10. Process from the beginning until the Pressure Regulator begins to rock gently. Lower the heat so that the lid and bucket remain in a slow, steady rocking of the pressure regulator. Steam will escape as the pressure regulator rocks gently in place. This is normal and bleed from many household foods. If it is not perfectly clear, clean the vent

11. When with adding sized has perded according to the recipe, turn heat setting of the burner the "OFF" and gently move the canner to a cold burner and let sit until cool.

6. Place the lid on the canner, aligning the ▼ mark on the lid with the

12. Let the canner cool naturally. Do not touch the body handle. Press away from the heat source naturally. Do not

down slightly the lid handle of the canner. Rapid reduction techniques can cause jar breakage and scaling or other dangerous problems. Pressure is completely reduced when the cover clockwise (right) to close back inside the handle and no steam escapes when the lid is closed. If the body and lid handles are centered directly over each other.

13. Do not rotate this lid beyond this point and let the canner cool for an additional 10 minutes undisturbed. Do not remove the pressure regulator until the air/vent cover lock has dropped and no additional

7. Place the canner on a level surface. Do not place on an uneven surface as this may

14. Turn the lid clockwise (left) until the lid handles Pressure Regulator can be used. If the lid is hard to turn and force at some sticking may indicate pressure is still in the canner. Let the canner

out of operation before high BTU energy levels and may cause the

also

and

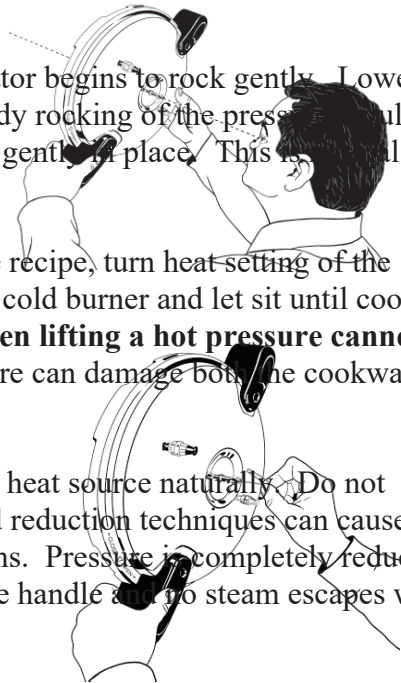

8. Vent the canner (also called “exhausting” the canner). As the water boils inside the canner, the “empty” space becomes a mixture of air and steam. The temperature of a steam/air mixture is lower than the temperature of pure steam. Venting eliminates (“exhausts”) the air so processing takes place in a pure steam environment. Process times in recipes are intended only for a pure steam environment. Using a relatively high heat setting, heat the pressure canner until a steady stream of steam flows freely from the open vent pipe. Exhaust the air from the canner for 10 minutes before reducing the heat and placing the pressure regulator on the vent pipe to start pressurizing the canner.

9. Assemble the Pressure Regulator to the desired canning pressure as determined by the recipe. Place the Pressure Regulator on the vent pipe and return the burner to a relatively high heat setting. As pressure develops inside the canner, the air/vent cover lock will lift. The air/vent cover lock is a visual indicator of pressure in the canner. When in the up position, pressure is in the canner. When in the down position, there is no pressure in the canner.

Regulator alone (5 psi)

Regulator+1 ring (10 psi)

Regulator+2 rings (15 psi)

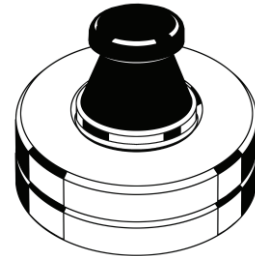
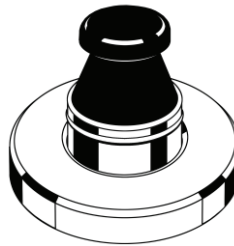
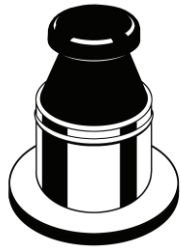

Pressurized and Locked
Cover locking pin is lifted



No Pressure and Unlocked
Cover locking pin is down

10. Processing time begins when the Pressure Regulator begins to rock gently. Lower the heat setting of the burner to maintain a slow, steady rocking of the pressure regulator. Steam will escape as the pressure regulator rocks gently in place. This is normal and how the unit should work.
11. When processing time has ended according to the recipe, turn heat setting of the burner to “OFF” and gently move the canner to a cold burner and let sit until cool.
Note: the canner is hot and heavy, use care when lifting a hot pressure canner. Do not slide it across the burner. Sliding cookware can damage both the cookware and the stovetops.
12. Let the pressure canner cool down away from the heat source naturally. Do not attempt to speed the cooling of the canner. Rapid reduction techniques can cause jar breakage and other potentially dangerous problems. Pressure is completely reduced when the air/vent cover lock drops back inside the handle and no steam escapes when the pressure regulator is lifted.
13. When pressure is completely reduced, remove the pressure regulator from the vent pipe and let the canner cool for an additional 10 minutes undisturbed. Do not remove the pressure regulator until the air/vent cover lock has dropped and no additional steam escapes when the pressure regulator is lifted. Always remove the pressure regulator before opening and removing the canner lid.
14. To remove the lid, turn the top handles counter-clockwise (left) until the lid handles move beyond the canner body handles, and the ▼ mark on the lid points to the ▲ mark on the canner body handle. If the lid is hard to turn and seems to stick, do not force it open. Sticking may indicate pressure is still inside the canner. Let the canner sit until completely cool before removing the lid if there is any doubt.

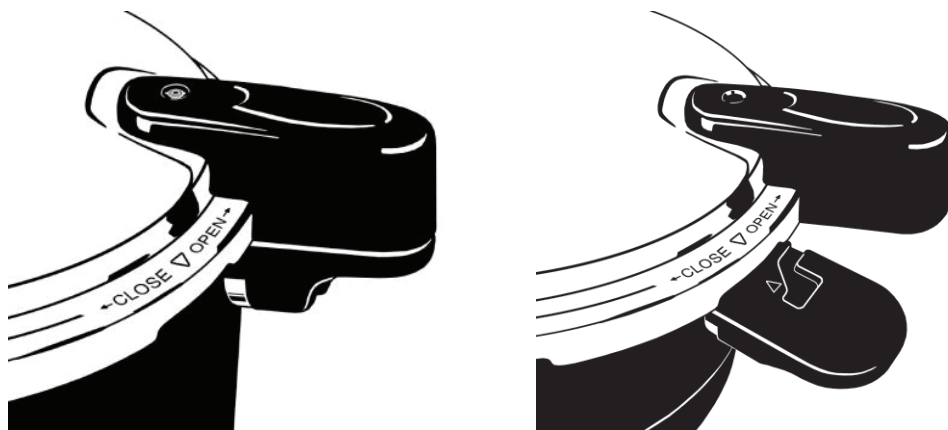

15. Lift the canner lid up and toward you. Use the lid like a shield to make sure the residual steam inside the canner goes away from you when opening.



16. Remove jars from canner using a Granite·Ware® jar lifter or similar tool. Set jars upright on a cutting board or dish cloth and away from any drafts to cool. When the jars are cold to the touch, test the seal, remove lid bands, wipe the jars clean, add label with contents and date, and store in a cool, dark, dry place.

CLEANING AND MAINTENANCE

1. The anodized finish of the Granite·Ware® pressure canner will last for many years with some simple care. Hand-wash the canner in warm soapy water and towel dry. Do not use bleach, wire brushes, scouring pads or other aggressive cleaning tools.
2. Each time the canner is washed, remove the lid gasket sealing ring and wash in warm soapy water, rinse, dry (lightly oil if necessary), and replace in cover.
3. The center vent pipe and back-up safety valves may be removed for occasional cleaning or replacing. To remove, turn the lid upside down and turn the threaded security nuts of the vent pipe and valves counterclockwise (left) to loosen. Use care when removing the vent pipe to keep the small gasket intact and in place for reattaching after cleaning. To reattach, push the vent pipe and valves back through their lid holes, and secure them with the threaded nut(s) by turning the nut clockwise (right) to tighten securely.
4. Do not let the pressure canner boil dry, and never pour water into a dry, overheated canner.
5. Use care not to damage the top rim of the canner body. Striking the rim with metal cooking utensils like spoons, spatulas and ladles may cause nicks or the lid to not fit properly and allow steam and/or pressure to escape unintentionally.
6. Do not store the canner with the cover locked in place. This may deform the sealing ring and cause unpleasant odors if not completely dry or vented. When not in use, invert the cover on the canner body and store in a dry place.
7. If the canner handles become loose, tighten the attachment screws with a screwdriver. Remove the lid gasket sealing ring to gain access to the lid handle screws. The body handle screws can be found on the underside of the handles.
8. If any parts become worn or damaged, do not use the pressure canner. Call one of the authorized part replacement services listed in the Replacement Part Guide on page 16.

MODEL NUMBER & COMPANY INFORMATION

This Granite·Ware® Pressure Canner, model # F0730, is marketed by Columbian Home Products, LLC. Terre Haute, IN 47804. Visit us online at www.columbianhp.com for more information.

REPLACEMENT PART GUIDE

Use the following part numbers when contacting an authorized replacement parts re-seller as listed on page 7. These parts fit Granite·Ware® Pressure Canner models F0730.

Any other servicing shall be performed by an authorized service representative.

| Part Number | Description |
|--------------------|---|
| F2040 | 3-piece Adjustable Pressure Regulator (complete set) |
| F2041 | Vent pipe with gasket and attachment nut (complete set) |
| F2042 | Spring Loaded Back-up safety valve (black top) |
| F2043 | No Spring Back-up safety valve / Alarm Whistle (Silver top) |
| F2044 | Lid Gasket Sealing Ring |
| F2045 | Canning Jar Rack |
| F2046 | Steamer Insert |
| F2047 | Set of 4 Handles and set screws |
| F2048 | Bottom Handle set screws only (2) |
| F2049 | Top Handle set screws only (set of 4) |

USDA FOOD CLASSIFICATIONS AND RECOMMENDED COOKING TIMES

High-Acid Foods

| Food Type | Pack Method | Process Time (minutes) | | PSI (pounds per square inch of pressure) | |
|---|-------------|------------------------|------------|--|----------------|
| | | Pint Jars | Quart Jars | Under 1,000 ft. | Over 1,000 ft. |
| Apples | Hot | 8 | 8 | 5 lb | 10 lb |
| Apricots | Raw | 10 | 10 | 5 lb | 10 lb |
| | Hot | 10 | 10 | 5 lb | 10 lb |
| Blackberries | Raw | 8 | 10 | 5 lb | 10 lb |
| | Hot | 8 | 8 | 5 lb | 10 lb |
| Blueberries | Raw | 8 | 10 | 5 lb | 10 lb |
| | Hot | 8 | 8 | 5 lb | 10 lb |
| Cherries | Raw | 10 | 10 | 5 lb | 10 lb |
| | Hot | 8 | 10 | 5 lb | 10 lb |
| Grapefruit | Raw | 8 | 10 | 5 lb | 10 lb |
| | Hot | 10 | 10 | 5 lb | 10 lb |
| Nectarines | Raw | 10 | 10 | 5 lb | 10 lb |
| | Hot | 10 | 10 | 5 lb | 10 lb |
| Oranges | Raw | 8 | 10 | 5 lb | 10 lb |
| | Hot | 10 | 10 | 5 lb | 10 lb |
| Peaches | Raw | 10 | 10 | 5 lb | 10 lb |
| | Hot | 10 | 10 | 5 lb | 10 lb |
| Pears | Hot | 10 | 10 | 5 lb | 10 lb |
| Plums | Raw | 10 | 10 | 5 lb | 10 lb |
| | Hot | 10 | 10 | 5 lb | 10 lb |
| Raspberries | Raw | 8 | 10 | 5 lb | 10 lb |
| | Hot | 8 | 8 | 5 lb | 10 lb |
| Rhubarb | Hot | 8 | 8 | 5 lb | 10 lb |
| Tomatoes - Juice (with acid added) | Hot | 20 | 15 | 10 lb | 15 lb |
| | Hot | 20 | 15 | 10 lb | 15 lb |
| Tomatoes - Whole or Halved - No Liquid (with acid added) | Raw | 40 | 40 | 10 lb | 15 lb |
| | Raw | 25 | 25 | 10 lb | 15 lb |
| Tomatoes - Crushed, Quartered - No Liquid Added (with acid added) | Hot | 20 | 20 | 10 lb | 15 lb |
| | Hot | 15 | 15 | 10 lb | 15 lb |

Low-Acid Foods

| Food Type | Pack Method | Process Time (minutes) | | PSI (pounds per square inch of pressure) | |
|--------------------------------------|--|------------------------|------------|--|----------------|
| | | Pint Jars | Quart Jars | Under 1,000 ft. | Over 1,000 ft. |
| Artichokes | Hot | 25 | 25 | 10 lb | 15 lb |
| Asparagus | Raw | 30 | 40 | 10 lb | 15 lb |
| | Hot | 30 | 40 | 10 lb | 15 lb |
| Beans or Peas (shelled, dried) | Hot | 75 | 90 | 10 lb | 15 lb |
| | Raw | 75 | 90 | 10 lb | 15 lb |
| Beans, Dry | Hot | 65 | 75 | 10 lb | 15 lb |
| Beans, Fresh Lima (shelled) | Hot | 40 | 50 | 10 lb | 15 lb |
| | Raw | 40 | 50 | 10 lb | 15 lb |
| Beans (green, yellow, snap, Italian) | Raw | 20 | 25 | 10 lb | 15 lb |
| | Hot | 20 | 25 | 10 lb | 15 lb |
| Beets | Hot | 30 | 35 | 10 lb | 15 lb |
| Broccoli | Canning is not recommended. Best to freeze or pickle for preservation. | | | | |
| Brussels Sprouts | Canning is not recommended. Best to freeze or pickle for preservation. | | | | |
| Cabbage | Canning is not recommended. Best to keep in cold storage. | | | | |
| Carrots | Raw | 25 | 30 | 10 lb | 15 lb |
| | Hot | 25 | 30 | 10 lb | 15 lb |
| Cauliflower | Canning is not recommended. Best to freeze for preservation. | | | | |
| Corn, Cream Style | Hot | 85 | n/a | 10 lb | 15 lb |
| Corn, Whole Kernel | Raw | 55 | 85 | 10 lb | 15 lb |
| | Hot | 55 | 85 | 10 lb | 15 lb |
| Eggplant | Canning is not recommended. | | | | |
| Lima Beans | Raw | 40 | 50 | 10 lb | 15 lb |
| | Hot | 40 | 50 | 10 lb | 15 lb |
| Mushrooms | Hot | 45 | n/a | 10 lb | 15 lb |
| Okra | Raw | 25 | 40 | 10 lb | 15 lb |
| | Hot | 25 | 40 | 10 lb | 15 lb |
| Peas, Green or English (shelled) | Raw | 40 | 40 | 10 lb | 15 lb |
| | Hot | 40 | 40 | 10 lb | 15 lb |
| Peas (snap) | Canning is not recommended. Best to freeze for preservation. | | | | |
| Peppers | Hot | 35 | n/a | 10 lb | 15 lb |
| Potatoes, White | Hot | 35 | 40 | 10 lb | 15 lb |
| Potatoes, Sweet | Hot | 65 | 90 | 10 lb | 15 lb |

| | | | | | |
|--|--|-----|-----|-------|-------|
| Pumpkin | Hot | 55 | 90 | 10 lb | 15 lb |
| Spinach (and other greens) | Hot | 70 | 90 | 10 lb | 15 lb |
| Squash (summer) | Canning is not recommended. Best eaten fresh.. | | | | |
| Squash (winter) | Hot | 55 | 90 | 10 lb | 15 lb |
| Vegetable Soup | Hot | 60* | 75* | 10 lb | 15 lb |
| * Caution: Process 100 minutes if soup contains seafoods | | | | | |

Poultry, Red Meats and Seafood

| Food Type | Pack Method | Process Time (minutes) | | PSI (pounds per square inch of pressure) | |
|-----------------------------------|-------------|------------------------|------------|--|----------------|
| | | Pint Jars | Quart Jars | Under 1,000 ft. | Over 1,000 ft. |
| Chicken or Rabbit (without bones) | Raw | 75 | 90 | 10 lb | 15 lb |
| | Hot | 75 | 90 | 10 lb | 15 lb |
| Chicken or Rabbit (with bones) | Hot | 65 | 75 | 10 lb | 15 lb |
| | Raw | 65 | 75 | 10 lb | 15 lb |
| Chicken Stock (Broth) | Hot | 20 | 25 | 10 lb | 15 lb |
| Ground or Chopped Meat | Hot | 75 | 90 | 10 lb | 15 lb |
| Strips, Cubes or Chunks of Meat | Hot | 75 | 90 | 10 lb | 15 lb |
| | Raw | 75 | 90 | 10 lb | 15 lb |
| Meat Stock (Broth) | Hot | 20 | 25 | 10 lb | 15 lb |
| Chili Con Carne | Hot | 75 | n/a | 10 lb | 15 lb |
| Clams | Hot | 70 | n/a | 10 lb | 15 lb |
| Crab Meat (King and Dungeness) | Hot | 80 | n/a | 10 lb | 15 lb |
| Fish (except Tuna) | Raw | 100 | 160 | 10 lb | 15 lb |
| Fish, Smoked | Hot | 110 | n/a | 10 lb | 15 lb |
| Fish, Tuna | Raw | 100 | n/a | 10 lb | 15 lb |
| | Hot | 100 | n/a | 10 lb | 15 lb |
| Oysters | Hot | 75 | n/a | 10 lb | 15 lb |

ADDITIONAL RECIPE AND INFORMATION RESOURCES

There are many sources of home canning recipes and information available from various sources. Here are some of our favorite resources for home canning and food preservation information, recipes and helpful hints and tips.

Ball Blue Book: Guide to Preserving

United States Department of Agriculture (USDA)

http://nchfp.uga.edu/publications/publications_usda.html

Steps to Success in Home Canning: University of Missouri Extension

<http://extension.missouri.edu/publications/DisplayPub.aspx?P=GH1452>

National Center for Home Food Preservation: University of Georgia Extension

<http://nchfp.uga.edu/index.html>

Cooperative Extension System: National Institute of Food and Agriculture

<http://www.csrees.usda.gov/Extension/>

Food.com Home of the Home Cook

<http://www.food.com/recipes/pressure-canning>

Food in Jars

<http://www.foodinjars.com/>