

Operation Manual

ER&D Model DA100 RF Distribution Amplifier



105 South Locust St.
Shiremanstown, PA 17011
Phone: (717) 348-5326

email: sales@esterlineresearch.com

Revision B

Performance Certification

Esterline Research and Design (ERD) certifies that this product was 100% tested to validate compliance with its published specifications at the time of shipment.

Warranty

This product is warranted against defects in materials and workmanship for a period of one (1) year from the date of shipment.

Service

This product is neither designed nor documented for user repair; it must be returned to the factory for warranty or non-warranty service or repair. To avoid unnecessary delays, please contact the factory for authorization before returning this product for repair.

Information in this document is subject to change without notice.

Copyright © Esterline Research and Design, LLC, 2014. All rights reserved.

Esterline Research and Design, LLC
105 South Locust St.
Shiremanstown, PA 17011
Phone: (717) 348-5326

email: sales@esterlinerresearch.com

Table of Contents

1	Product Overview
6	Amplifier Options
7	Mechanical Specifications
8	Electrical Specifications

Product Overview:

The function of a Distribution Amplifier is to create multiple copies of a signal while minimally degrading its integrity. The DA100 Distribution Amplifier is designed to distribute a low noise signal to multiple usage points, such as Automated Test Systems or Test Benches where equipment requiring such signals may be employed.

The amplifier has one input and five outputs as seen in Figure 1 below. The device may be configured with either SMA or BNC connectors (see Options Section for more information). The input is AC coupled and offers an input source impedance of 50 Ω .



Figure 1: DA100-10M00-BNC Distribution amplifier with BNC connector option

The input is conditioned by a limiter circuit, which provides a fixed output level over wide variations of input power. This circuit also makes the amplifier tolerant of essentially any waveform with a duty cycle near 50%. The plot provided in Figure 2 below illustrates the output power of all five channels as a function of input power. This performance was measured on a DA100, configured for operation at 10 MHz.

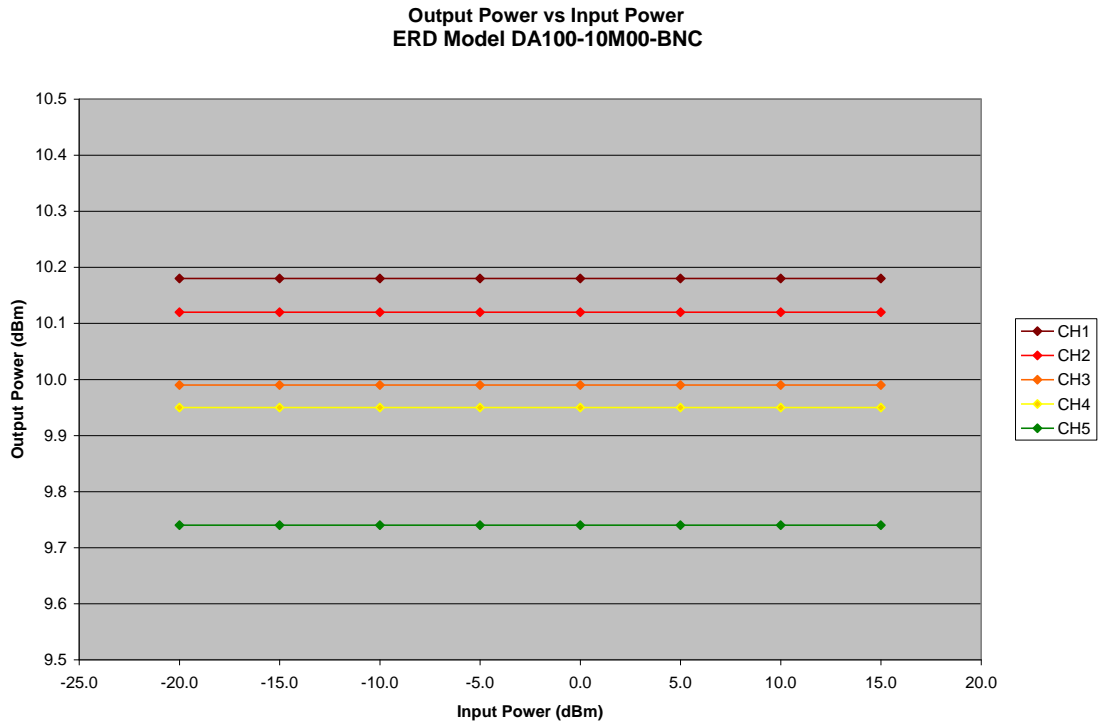

Figure 2: Output Power vs Input Power

The input limiter is followed by three amplifier/low pass filter stages, which insure low distortion sine wave outputs. The outputs from the filter stages are supplied to fixed gain output amplifiers as illustrated Figure 3 below. This configuration minimizes channel to channel phase offsets (<1 nS); the phase offset from the input to any output is less than 5 nS at 10 MHz.

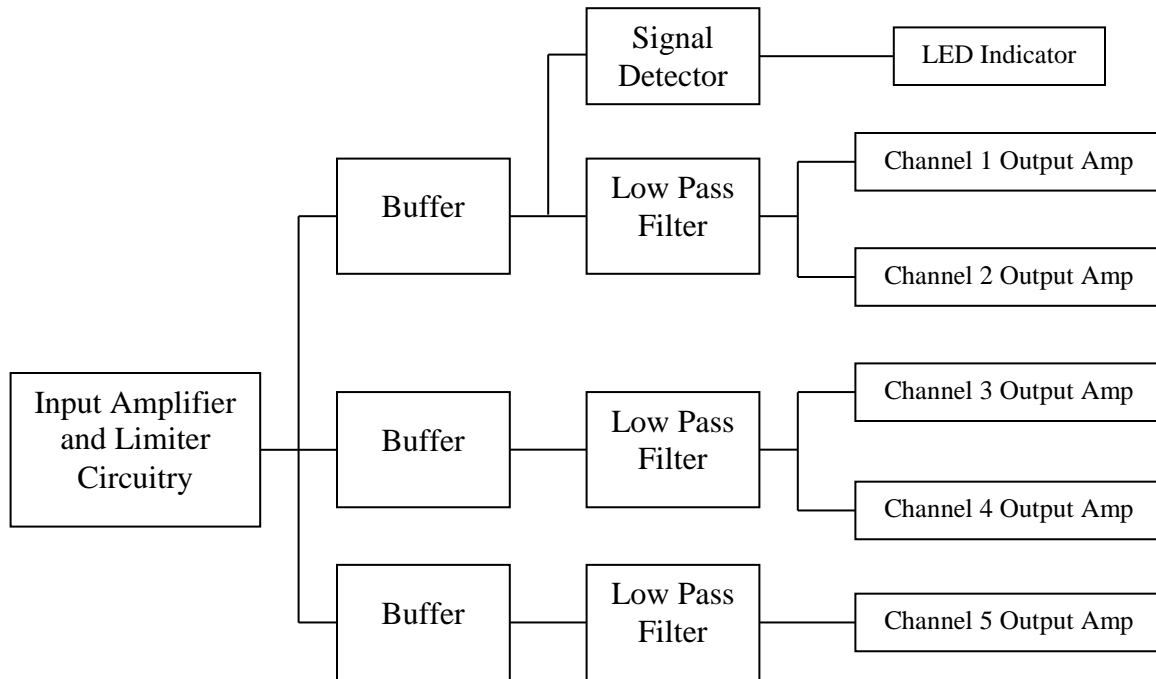

Figure 3: Functional Block Diagram

A multi-colored LED located near the RF input connector serves as an indicator of normal device operation: Blue will indicate the presence of a valid input signal and Red will indicate an invalid input signal and the presence of DC power (no illumination indicates the absence of DC power).

Operation:

Power is applied to the unit either through the 2.1 mm DC Power Jack using the supplied 6 V / 500 mA Power Supply Module or through the Screw Terminal Connector with a regulated voltage supplied by the user. When the Power Supply Module is utilized, its voltage is made available at the Screw Terminal Connector so that the user may power external circuitry with up to 250 mA of current.

Caution: The Screw Terminal Connector is directly connected to the 2.1 mm DC Power Jack. Do not attempt to apply power to both connectors simultaneously as damage to the power supplies and/or amplifier may occur.

The amplifier will provide the specified output level on all five channels with an input power level as low as -10 dBm. If additional output channels are needed, amplifiers may be ‘daisy-chained’ together using the output of channel five as the input to another amplifier as shown in Figure 4 below, where two 10 MHz amplifiers are connected together. This configuration is the most economical solution for channel expansion. However, it is not the best solution for minimal signal degradation (each amplifier will inject some noise) and cumulative channel to channel phase error (CH9 will lag CH4 by at least 5 nS due to the second amplifier’s input to output delay time and cable length coupling the two amplifiers).

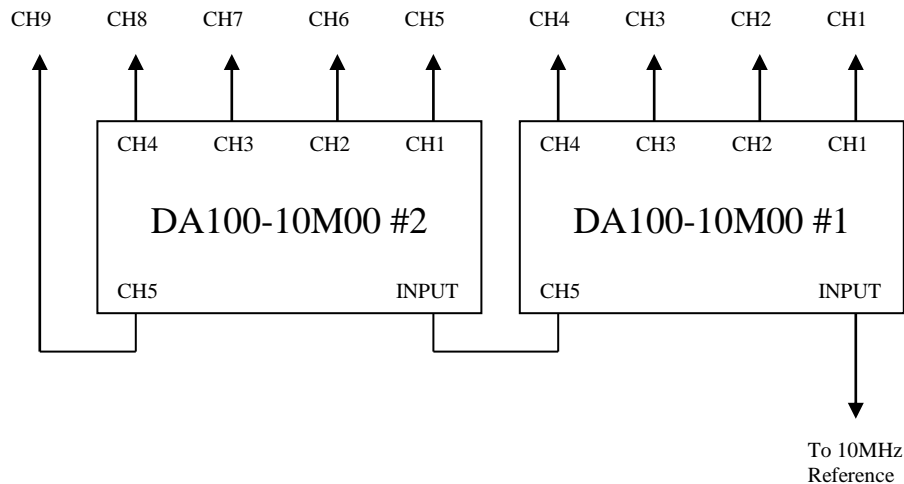

Figure 4: ‘Daisy-Chaining’ Amplifiers for Channel Expansion

Although more expensive, the best solution for channel expansion is to use a single amplifier as a driver for additional amplifiers. This configuration is illustrated in Figure 5 below and will provide the least amount of noise degradation and channel to channel phase error.

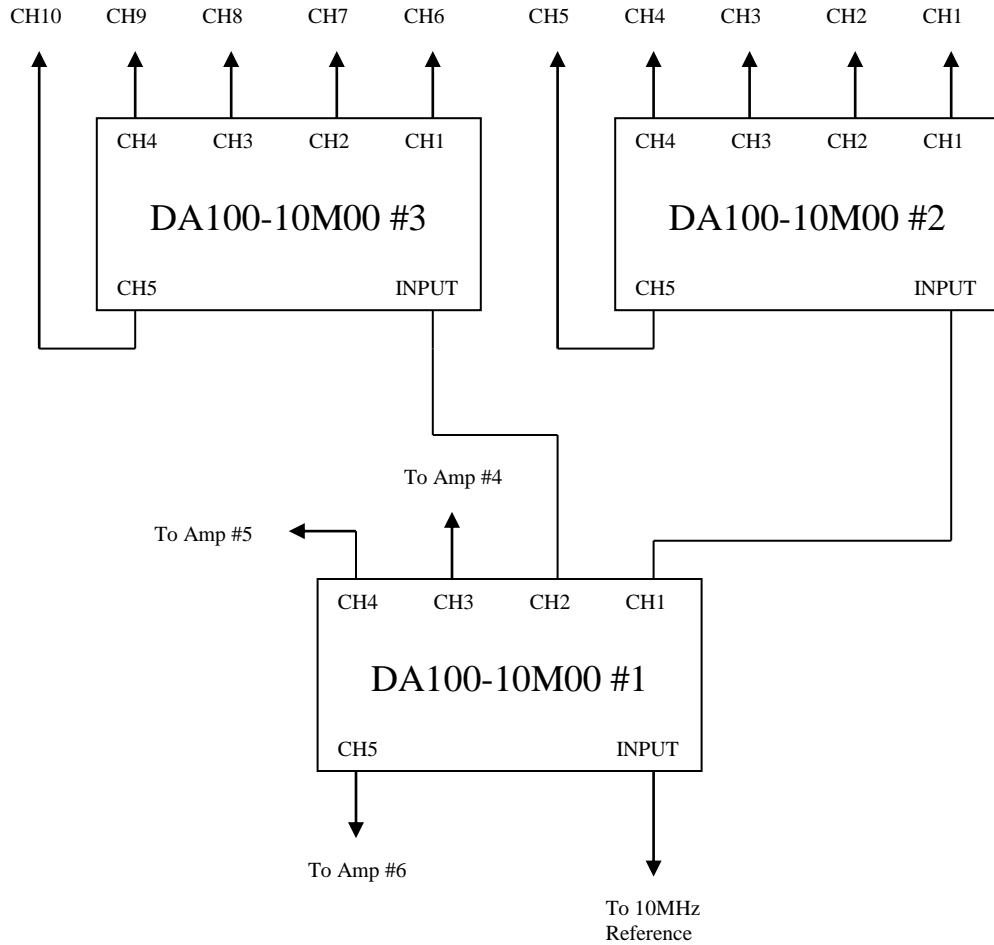
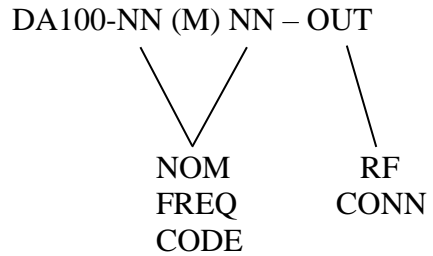

Figure 5: Cascading Amplifiers for Channel Expansion

Amplifier Options:

The DA100 Distribution Amplifier can accommodate a wide variety of applications, making it a unique solution for either stand-alone or imbedded applications.

The Model Number format for the amplifier is as follows:



NOM FREQ CODE: EXAMPLE: 10.23 MHz = 10M23

RF CONN: ‘SMA’ or ‘BNC’

Mechanical Specifications:

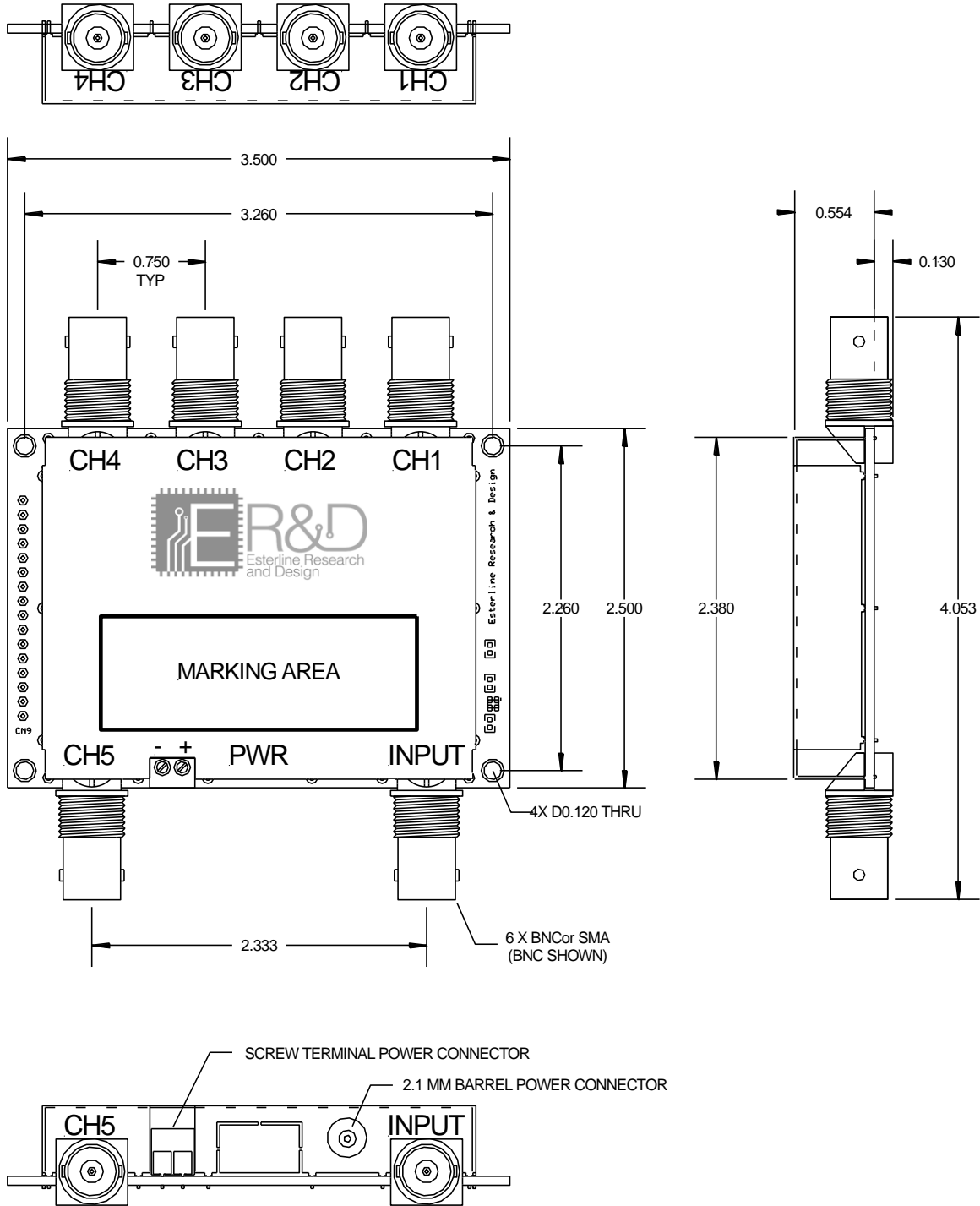

All dimensions are in inches with a tolerance of ± 0.020 "

Electrical Specifications:

RF Distribution Amplifier

Parameter	Minimum Limit	Maximum Limit	Units
Input Characteristics:¹			
Frequency Range ²	1.00	100.00	MHz
Amplitude	-10.0	+16.0	dBm
	0.20	4.00	Vpp
Impedance (AC Coupled)	45	55	Ω
Output Characteristics (Sine):			
THD:	N/A	1	%
Amplitude (50 Ω Load)	+9.0	+11.0	dBm
	0.63	0.79	Vrms
	1.78	2.24	Vpp
Amplitude (High-Z Load)	1.00	1.30	Vrms
	2.83	3.68	Vpp
Channel to Channel Isolation (at 10 MHz)	70	N/A	dB
Power Requirements:³			
Voltage	6	12	VDC
Current (at 10 MHz)	N/A	250	mA

Notes:

- ¹ Input signal waveform can be any type with a 50% duty cycle.
- ² Amplifiers are configured for fixed-frequency operation at any frequency between 1 MHz and 100 MHz, with a bandwidth of $\pm 5\%$.
- ³ The device may be powered with a user-supplied voltage via the screw terminal connections or by the 2.1 mm jack (center pin +) on the included 6 V, 500 mA power module. When the power module is utilized, the module voltage is made available on the screw terminals thus allowing the user to access 6 V, 250 mA to power external circuitry.

Caution: Do not connect an external supply voltage to the screw terminals when using the power module.