

**2X72 START-UP  
INSTRUCTIONS**

**BRODBECK IRONWORKS LLC**

**REVISION -**

## Contents

STEP 1 – Gas Spring.....	6
STEP 2 – Tracking Knob and Handle.....	7
STEP 3 – Tracking Wheel .....	7
STEP 4 - Motor Installation.....	8
STEP 5 - Drive Wheel Installation.....	9
STEP 6 – Platen Handle Installation.....	10
STEP 7 – Adjustable Work Rest Arm Installation.....	11

**WARNING:**

**THE OPERATION OF THIS MACHINE MAY RESULT IN INJURY, DISMEMBERMENT, OR DEATH.**





**Lockout and secure power source before performing any work on the machine.**



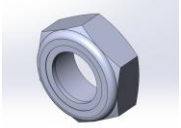
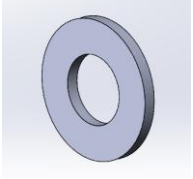

**Make sure to use adequate personal protection equipment such as eye protection, respirator, etc. while operating this equipment.**

Contact Brodbeck Ironworks LLC for any questions or concerns before operating this equipment

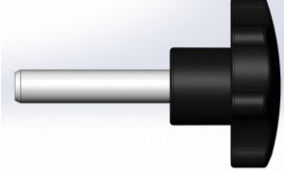
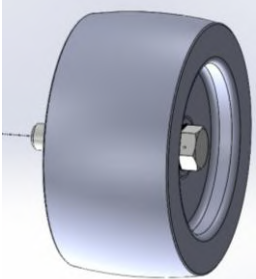
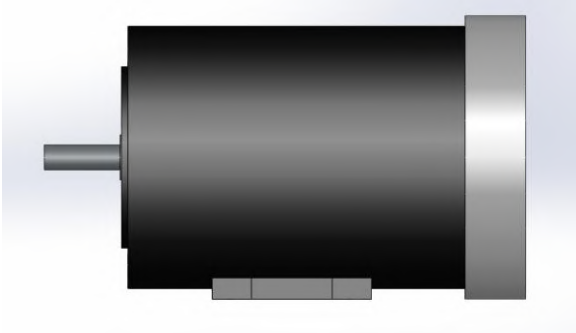
Ben Secrist 513-532-7062, [Ben@brodbeckironworks.com](mailto:Ben@brodbeckironworks.com)

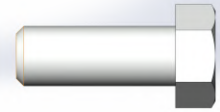
Parts List:

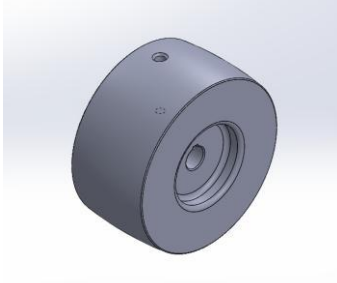
ITEM	DESCRIPTION	QTY	IMAGE
1	5/16" THIN LOCK NUT	1	
2	1/4" FLAT WASHER	2	
3	GAS SPRING (20LB)	1	
4	GAS SPRING EYELET	1	
5	5/16" HEX BOLT 1" LONG	1	
6	3/8" THREADED TAPERED HANDLE	1	
7	LOBED TRACKING KNOB 3/8" THREADED	1	
8	4" TRACKING WHEEL W/ BOLT & WASHER	1	
9	MOTOR	1	

10	3/8" HEX BOLT 1" LONG	4	
11	3/8" SPLIT LOCK WASHER	4	
12	5" DRIVE WHEEL	1	
13	1/4" SET SCREW 1/2" LONG	1	

## STEP 1 – Gas Spring

Screw gas spring into the top eye.

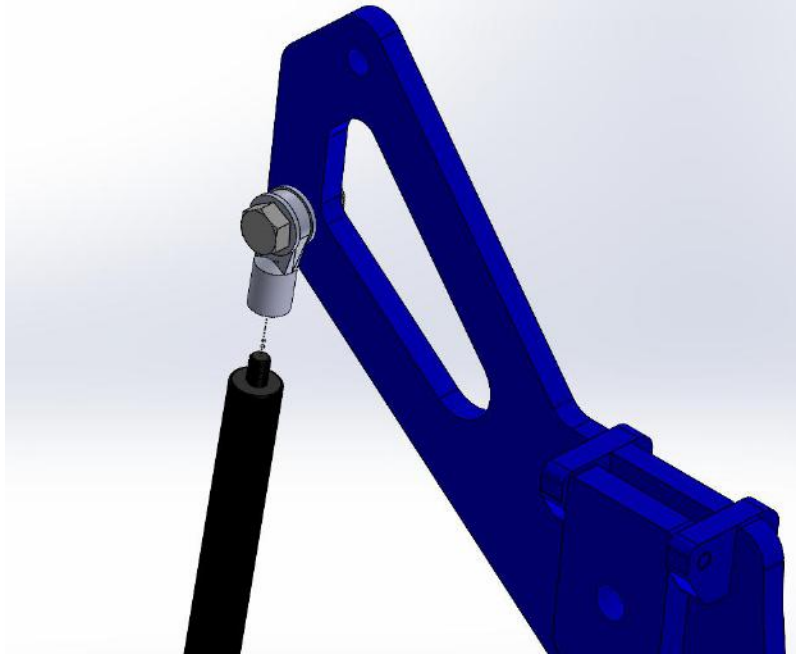

Install the gas spring using 5/16-18 x 1.00" hex bolt, a flat washer on both sides of each eye, and nylock nut.

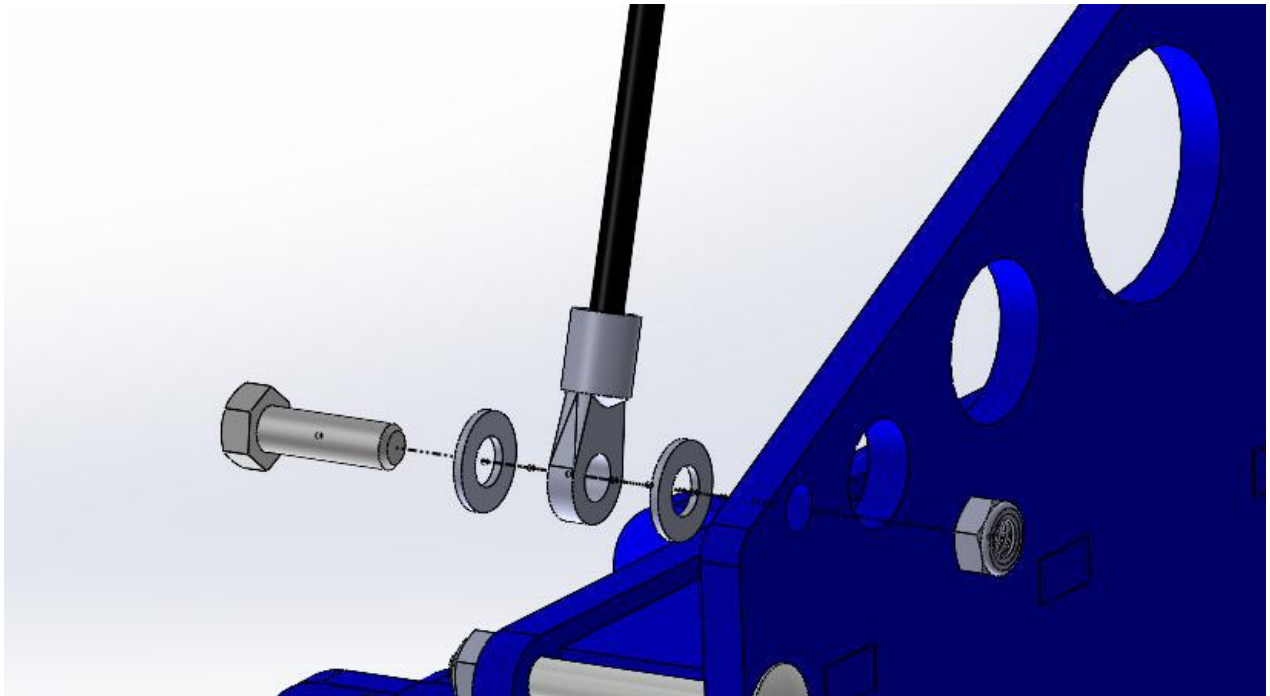

Do not overtighten the gas spring bolts. It will bind and cause tracking issues and premature failure.

### STEP 2 – Tracking Knob and Handle

Insert 3/8-16 threaded handle into the tension arm (apply loctite). Install 3/8-16 threaded knob into the tension arm. This will be used to adjust tracking in operation.

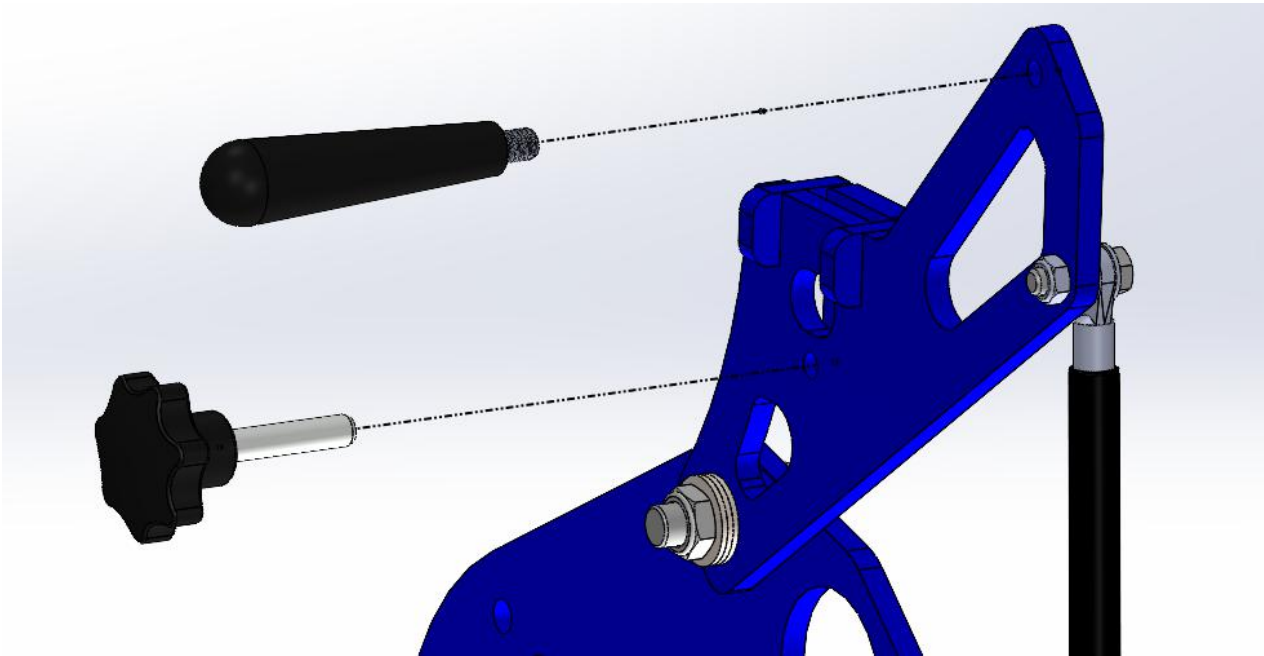

### STEP 3 – Tracking Wheel

Install the tracking wheel into the tracking arm using ½-13 x 3” hex bolt, nylock nut, and flat washer.

BE CAREFUL NOT TO OVERTIGHTEN BEARINGS. THE WHEEL SHOULD SPIN FREELY BUT THERE SHALL NOT BE EXTRA SPACE BETWEEN THE BEARINGS AND NUT OR BOLT HEAD.

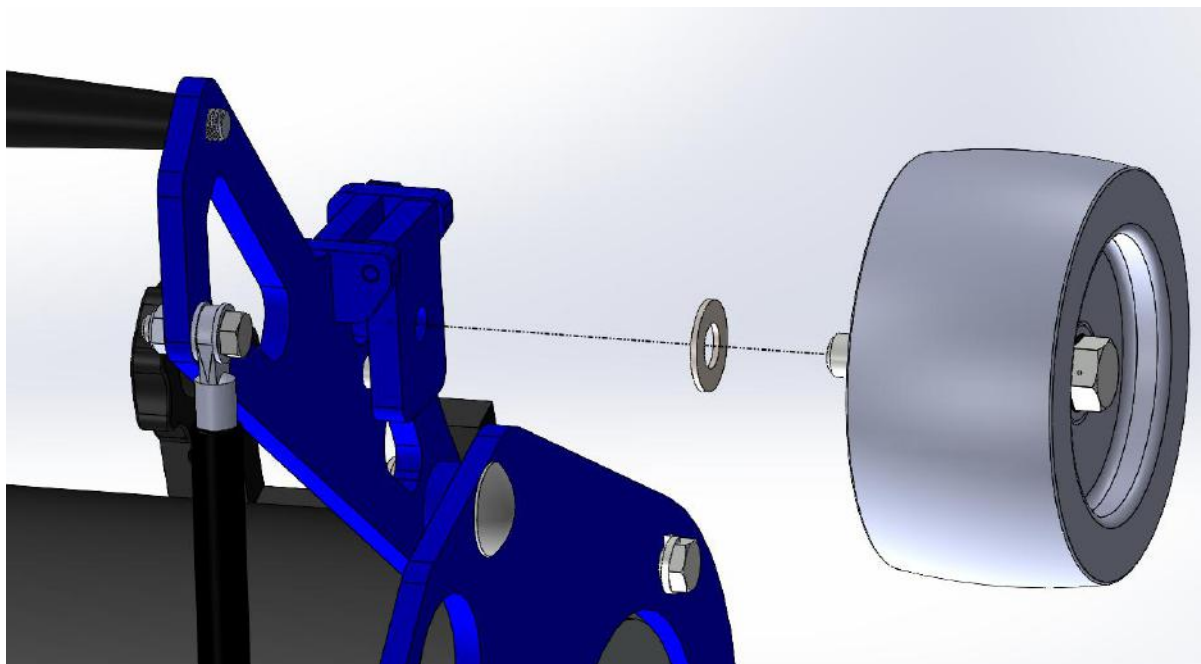

#### STEP 4 - Motor Installation

Tilt the chassis into the horizontal position. Install motor into belt side plate using 3/8-16 x 1 hex bolts and split lock washers. Make sure the feet of the motor are facing the rear of the machine.

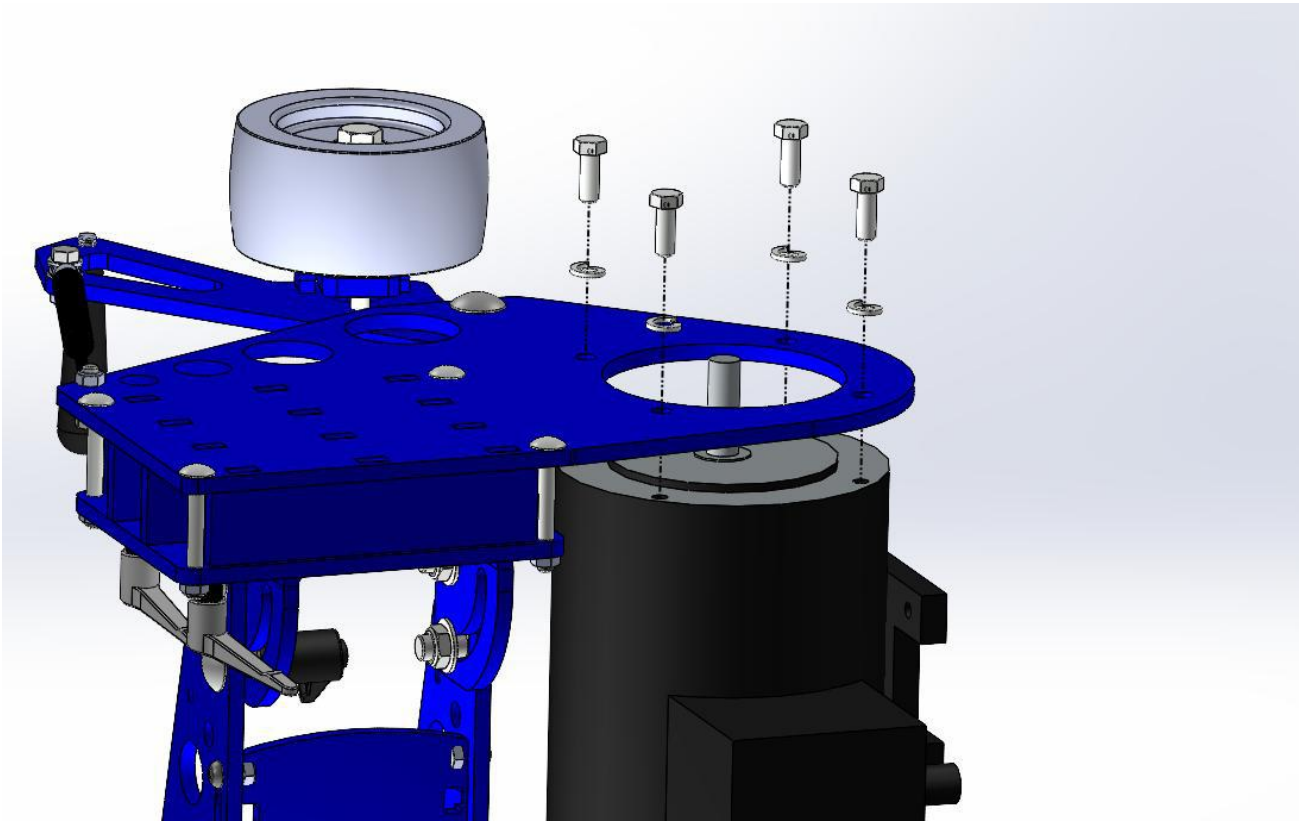



## STEP 5 - Drive Wheel Installation

Install drive wheel and secure with set screw.

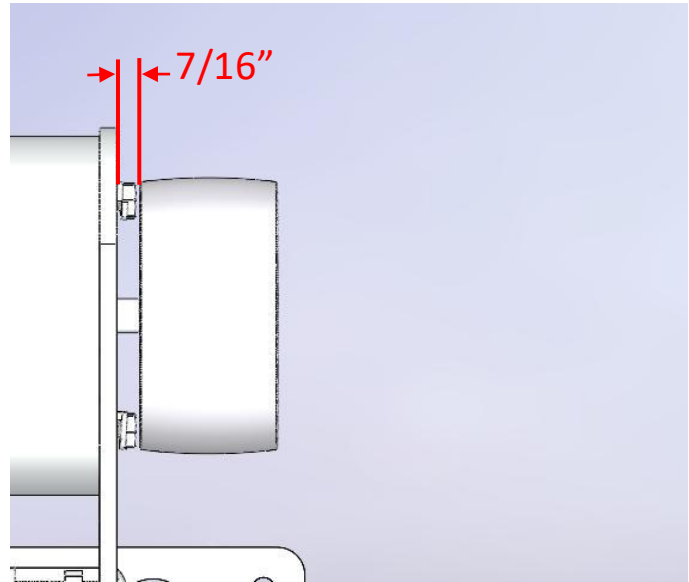
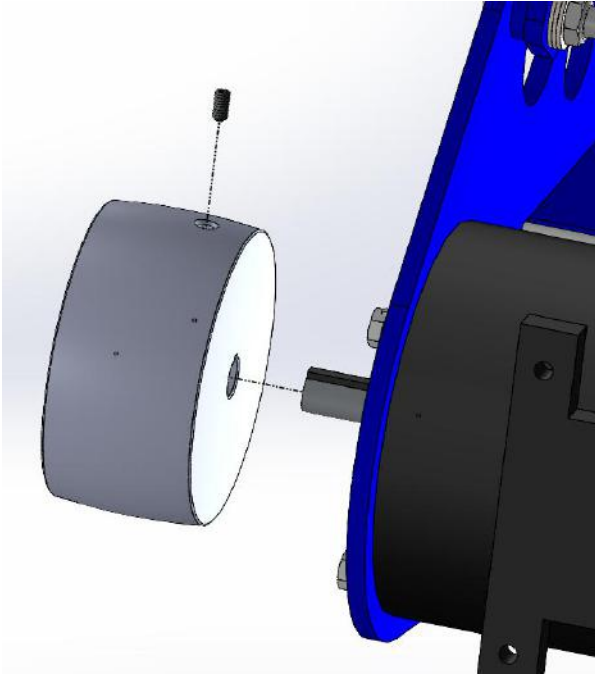

Align with other wheels to ensure proper tracking. The drive wheel should be approximately  $7/16$ " off of the side plate.

STEP 6 – Platen Handle Installation

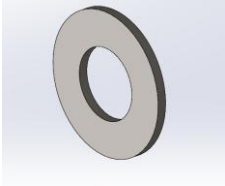
ITEM	DESCRIPTION	QTY	IMAGE
1	BLACK ADJUSTABLE HANDLE ½"-13 INTERNAL THREAD	1	
2	½" FLAT SAE WASHER	1	

Install the Handle and Washer to the platen assembly.

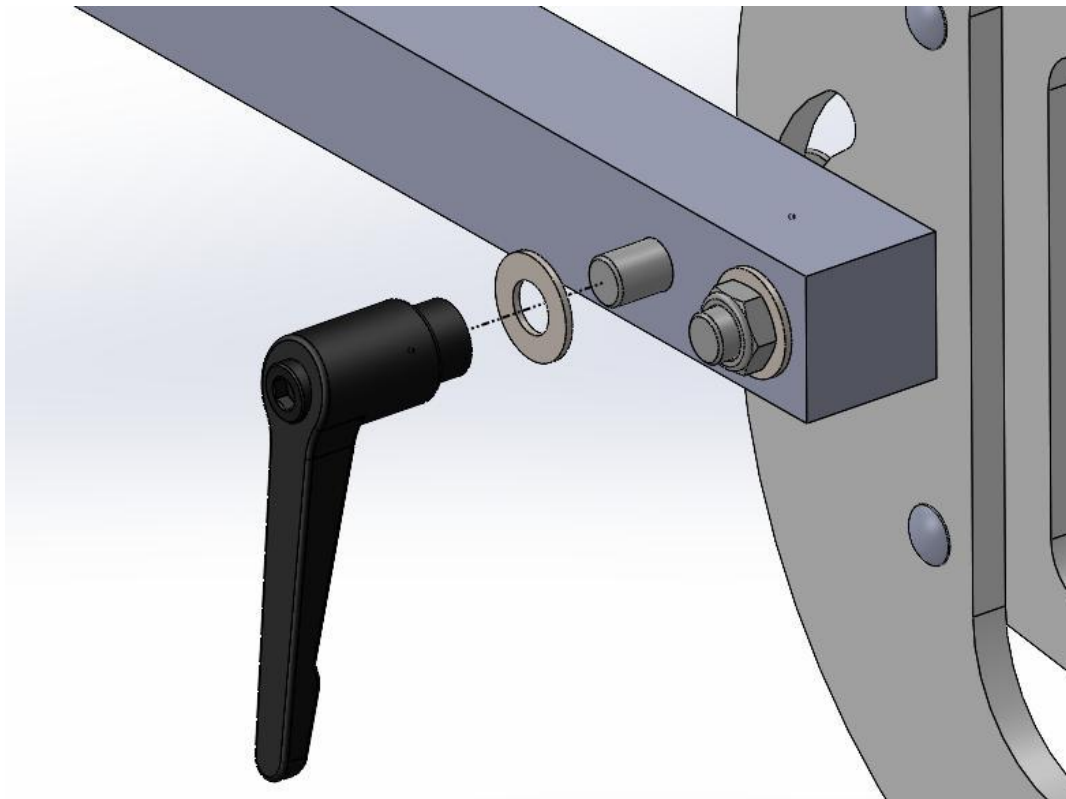

STEP 7 – Adjustable Work Rest Arm Installation

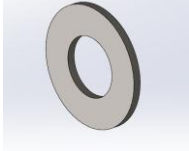
ITEM	DESCRIPTION	QTY	IMAGE
1	HEX BOLT ½" X 2.00" LG	2	
2	½" FLAT SAE WASHER	2	

Install the entire assembly onto the threaded tool arm (as shown) using the hex bolts and washers.

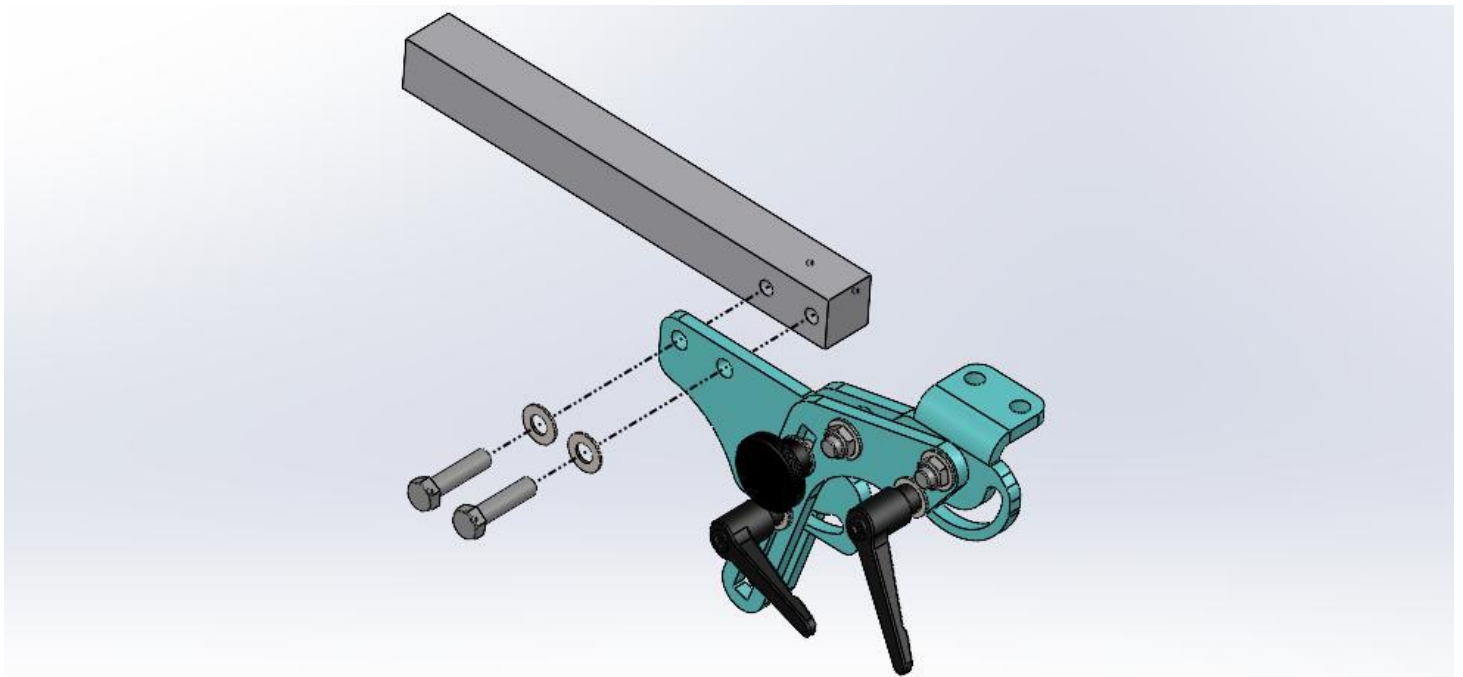

#### Additional Notes:

- Make sure all wheel centerlines are aligned with each other to ensure proper tracking. There may be some variance due to tolerance stack ups.
- To make sure the belt has enough tension, put the belt on all four wheels, pull and hold down the tension arm all the way, pull the platen arm out until the belt is tight, lock the platen arm in place, and release the tension arm.
- When adjusting tracking, start off rotating by hand or running the motor at a slow speed.
- Always adjust the speed on your VFD to 0 when starting after an attachment change
- The VFD Start/Stop switch is a three-way switch.
  - STOP (Bottom position)
  - RUN (Middle position)
  - START (Top Position, will spring back to middle)

**PLACE ALL WARNING LABELS ONTO THE MACHINE IN A VISIBLE LOCATION.**