



HITCHFIRE LEDGE

OWNER'S MANUAL

Read this manual carefully before assembly, using, or servicing this grill.

FOR OUTDOOR USE ONLY

PATENT PENDING

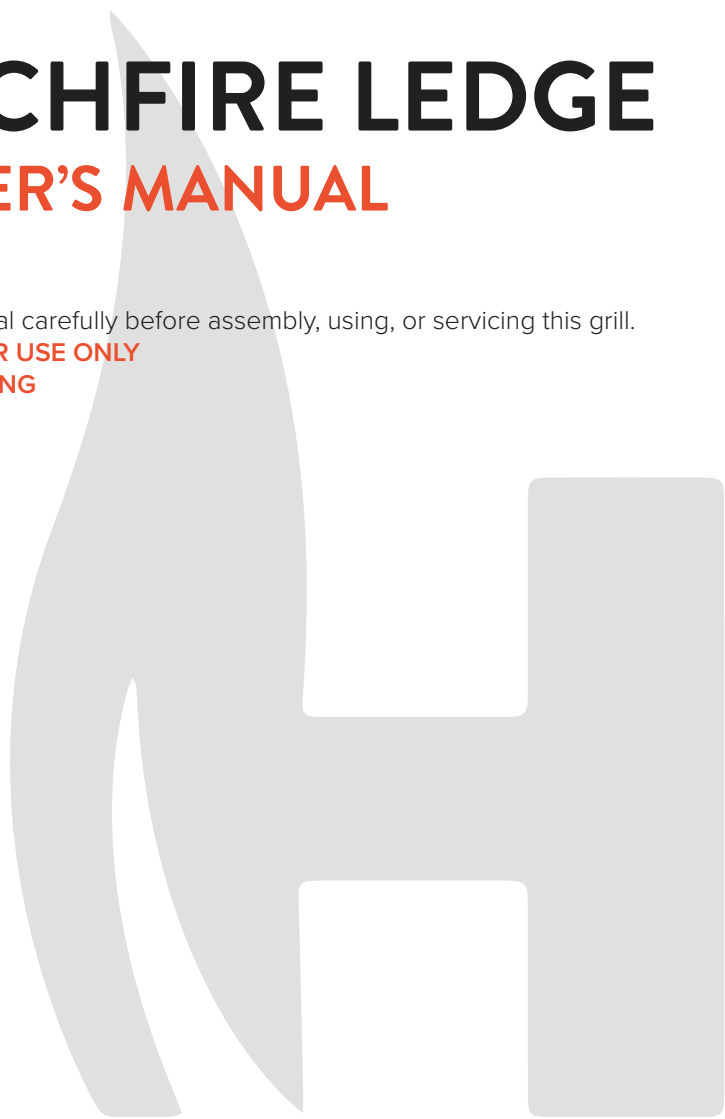

TABLE OF CONTENTS

OPERATING INSTRUCTIONS	4
PARTS LIST	5



OPERATING INSTRUCTIONS

1. Slide the swing away arm assembly into your hitch and secure it with the hitch stabilizer bolt
 - A. Tighten the bolt using a wrench, make sure to tighten the bolt all the way through to the other side of the hitch, slide the cotter pin into the bolt.
2. Pull out and twist the hinge spring lock. ‘
 - A. Release the slam-latch by pressing down on the lever.
3. Swing the arm away from the vehicle and lock at 90 degree position for stability. Place the Ledge platform onto the arm.
4. Clamp the quick release lever to secure the Ledge platform.
5. Lock the ledge platform head onto the arm with a padlock. (Not included)
6. Swing the arm closed, pushing towards the vehicle until the slam-latch is fully engaged.
7. Rotate the hinge spring lock to engage the plunger.

Use of phillips or flat head screw driver can be utilized to remove side rails to allow for larger

***The maximum allowable weight on the Ledge is 100 lbs when used with an adequate hitch receiver. Please consult your vehicle user manual to confirm Class III hitch classification.

PARTS LIST



Removable Side Rails

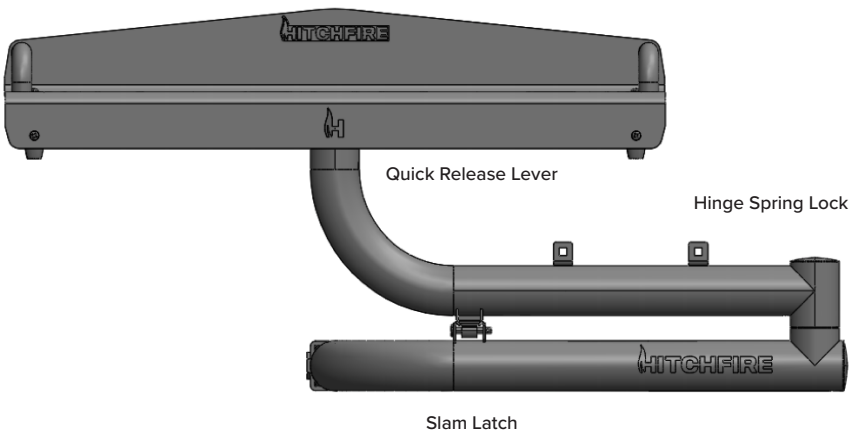
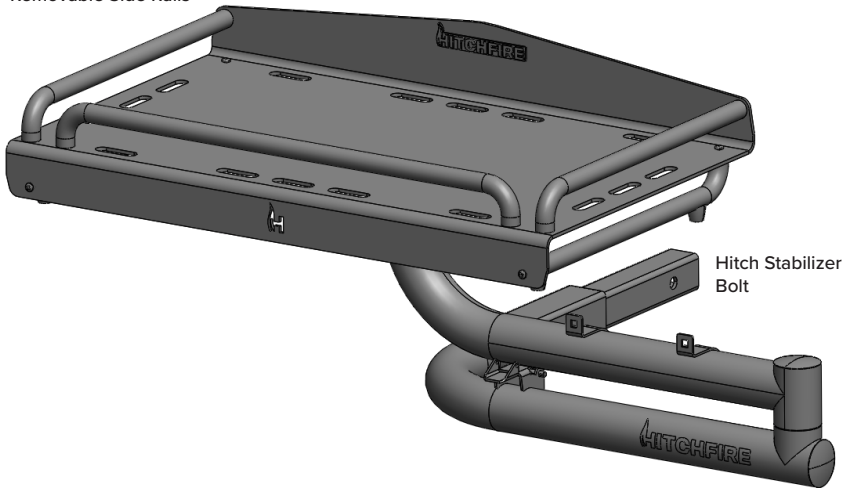

ASSEMBLY - ATTACHING THE GRILL

- 1** Slide the swing away arm assembly into your hitch and secure it with the hitch stabilizer bolt.

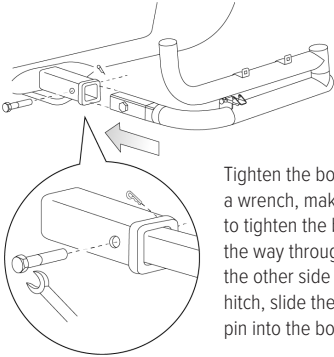

Tighten the bolt using a wrench, make sure to tighten the bolt all the way through to the other side of the hitch, slide the cotter pin into the bolt.

⚠ DO NOT MOVE VEHICLE UNLESS THE SWING AWAY ARM ASSEMBLY IS SECURELY BOLTED ONTO THE HITCH.

- 2** **A.** Pull out and twist the hinge spring lock.
B. Release the slam-latch by pressing down on the lever.

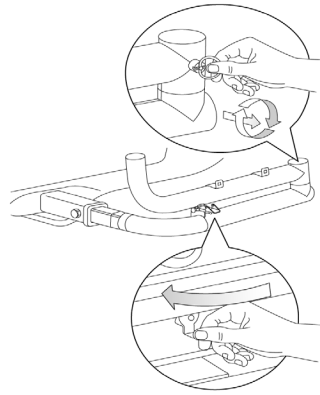

- 3** Swing the arm away from the vehicle and lock at the 90 degree position for stability. Place the Ledge platform onto the arm.

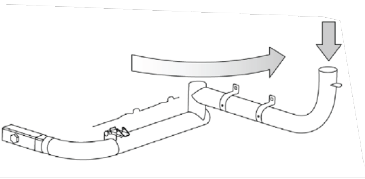

- 4** Clamp the quick release lever to secure the grill to the arm.

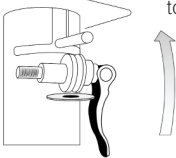

- 5** Lock the ledge onto the arm with a padlock. (Not included.)

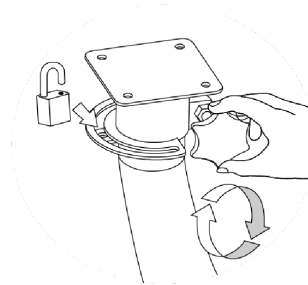

⚠ DO NOT MOVE VEHICLE UNLESS THE LEDGE IS LOCKED IN PLACE.



- 6 Swing the arm closed, pushing towards the vehicle until the slam-latch is fully engaged.
- 7 Rotate the hinge spring lock to engage the plunger.
- 8 Close hinge spring lock and slam-latch.

⚠ DO NOT MOVE VEHICLE UNLESS THE HINGE SPRING LOCK & SLAM-LATCH ARE SECURE.

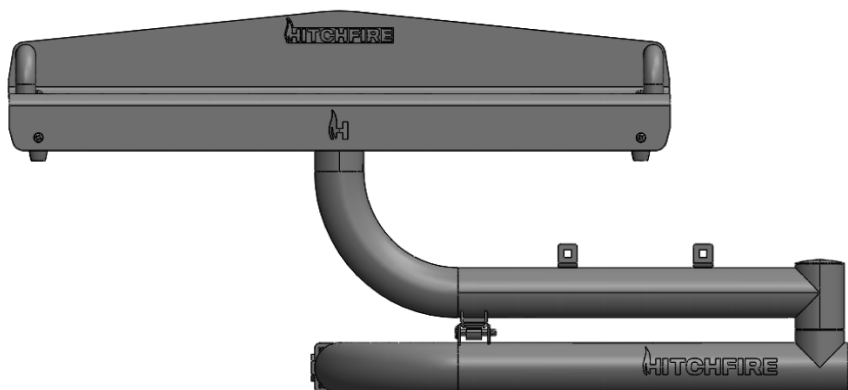

LIMITED WARRANTY

What Is Covered

HitchFire, warrants to the original purchaser that its products listed below are free from defects in material and workmanship, for the term described, except as qualified below. The life of the product is determined from the date of purchase until such time as the product is no longer serviceable due to normal wear and tear.

Steel & Aluminum Castings
Cooking Grates
Burners
Spark Igniters
All Remaining Parts

When Assembled and operated in accordance with the accompanying printed instructions.

What Is Not Covered

HitchFire shall not be responsible for the natural breakdown of materials that occurs inevitably with extended use (e.g., Ultra Violet (UV) light damage on grill, or defects caused by accident, abuse, alteration, animal attack, storm damage, misuse or improper care, vandalism, improper installation improper maintenance or service, failure to perform normal and routine maintenance, including but not limited to, damage caused by insects within the burner tubes, as set out in this owner's manual warranty section.

Deterioration or damage due to severe weather conditions such as hail, hurricanes, earthquakes, or tornadoes including rust, discoloration due to exposure to chemicals (including salt) either directly or in the atmosphere, or very high humidity, is not covered by this limited Warranty.

THERE ARE NO OTHER EXPRESS WARRANTIES BEYOND THE TERMS OF THIS LIMITED WARRANTY. IN NO EVENT SHALL HitchFire BE LIABLE FOR INCIDENTAL OR CONSEQUENTIAL DAMAGES.

Some states do not allow the exclusion or limitation of incidental or consequential damages, so the above limitation or exclusion may not apply to you.



What HitchFire Will Do

If after inspection we find that a product failed due to a manufacturing or material defect, we will repair or replace the product, at our option, without charge.

How To Obtain Warranty Service

Return the product, freight prepaid, to the HitchFire Dealer from whom it was purchased; or, contact HitchFire Customer Satisfaction Department for return authorization: toll free 1-800-515-5286. Collect shipments or shipments without return authorization cannot be accepted.

REPAIRS

If your HitchFire product needs service or repair due to normal wear and tear, animal attack, accident or some other reason that is not covered under the warranty we will provide the necessary service for a reasonable charge, plus shipping and handling. We require that products accepted for any repair be properly cleaned according to our recommended care instructions. Please send your product that requires repair, postage prepaid, along with a description of what needs attention. For service and repairs, please contact our Customer Satisfaction Department: toll free 1-800-515-5286

How State Law Relates To This Warranty

This warranty gives you specific legal rights, and you may have other rights that vary from state to state.

Warranty Term

Limited two year warranty applies to all grill components.

IMPORTANT USER/ CONSUMER:

This instruction manual contains important information necessary for the proper assembly and safe use of this appliance. Read and follow all warnings and instructions before assembling and using the appliance.

KEEP THIS MANUAL FOR REFERENCE

HITCH FIRE INC. (DBA HitchFire)

2510 Rosedale Ave.

Soquel, CA 95073

www.hitchfire.com

support@hitchfire.com

1-800-515-5286

@Hitchfire 