



HITCHFIRE CUTTING BOARD SIDE TABLE

OWNER'S MANUAL

Read this manual carefully before assembly, using, or servicing this item.

PATENT PENDING

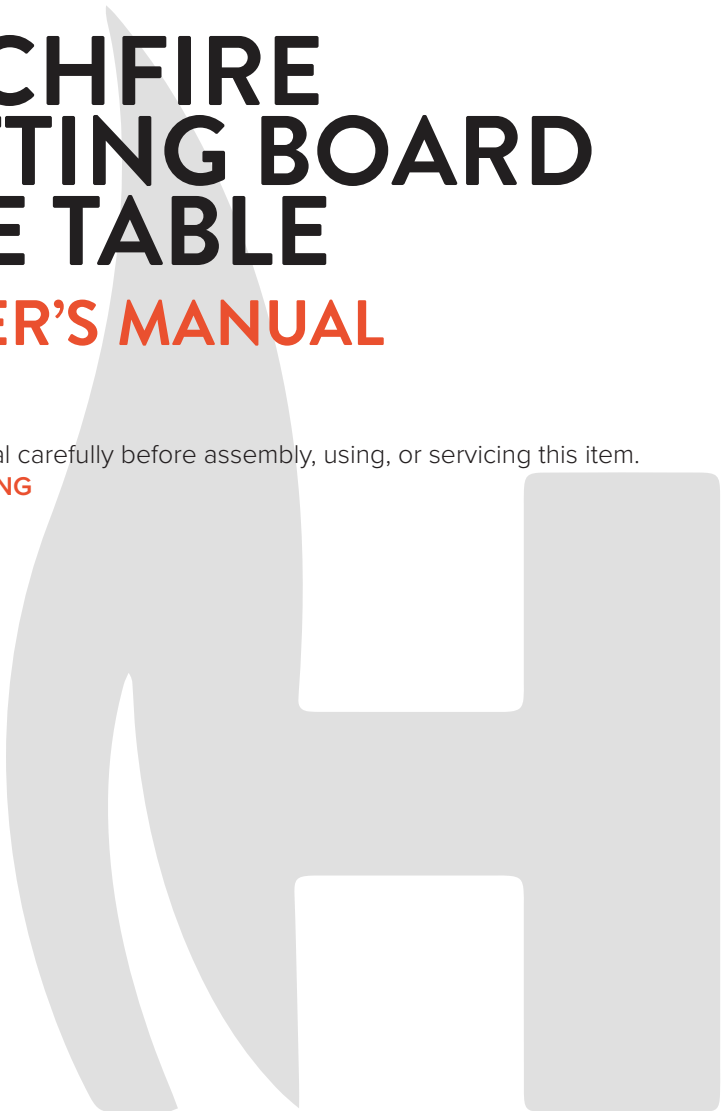

TABLE OF CONTENTS

OPERATING INSTRUCTIONS	4
PARTS LIST	5
ASSEMBLY INSTRUCTIONS	6
LIMITED WARRANTY	8



OPERATING INSTRUCTIONS

1. Remove the Cutting Board Side Table from weather proof carrying case and place top down on a flat surface.
2. Using the provided allen wrench, unscrew bolts holding legs to the bottom baseplate of the board being sure not to misplace them as they will be used to mount the board to the Swing Arm.
3. Locate the holes on the side of the lower arm of the swing arm. Set the curved end of one of the cutting board legs on the lower arm of the swing arm and thread one of the bolts through the leg hole and into the swing arm. Tighten.
4. Repeat step three for the second leg.
5. With both legs standing up on the lower arm of the swing arm, align the two square holes on the bottom of the cutting board baseplate with the legs on the swing arm. Use the remaining two allen bolts to secure the cutting board baseplate by tightening them down through the threaded hole on the sides of the square mounting holes on the bottom of the baseplate.
6. The bottom of the cutting board has two small silver latches to hold the baseplate in place. For best use, use a small Phillips head screwdriver to securely mount the cutting board to the baseplate.

PARTS LIST



Cutting Board (Top)



Cutting Board Bottom
(Baseplate & Legs Attached)

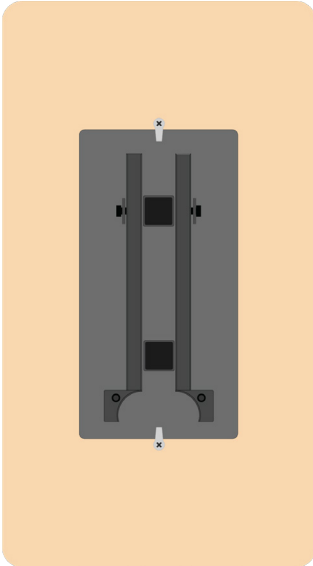

BASEPLATE ASSEMBLY

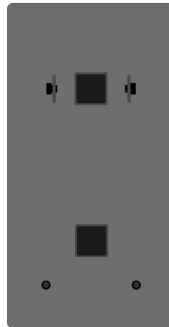

Baseplate

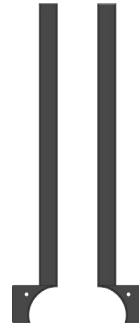

Legs x2

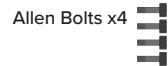

Allen Bolts x4

ASSEMBLY - ATTACHING THE CUTTING BOARD

- 1** Slide the swing away arm assembly into your hitch and secure it with the hitch stabilizer bolt.

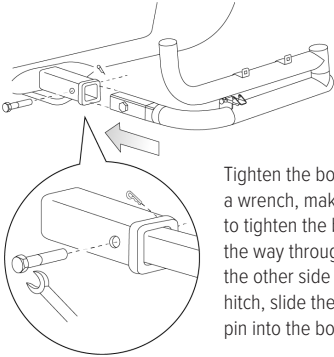

Tighten the bolt using a wrench, make sure to tighten the bolt all the way through to the other side of the hitch, slide the cotter pin into the bolt.

⚠ DO NOT MOVE VEHICLE UNLESS THE SWING AWAY ARM ASSEMBLY IS SECURELY BOLTED ONTO THE HITCH.

- 2** **A.** Pull out and twist the hinge spring lock. **B.** Release the slam-latch by pressing down on the lever.

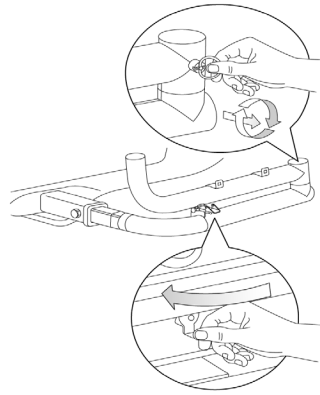

- 3** Swing the arm away from the vehicle and lock at the 90 degree position for stability.

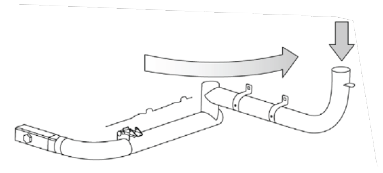

- 4** Using two allen bolts, mount legs to the lower arm of the swingarm.

Once legs are secure, place cutting board on top of legs and screw bolts in to secure surface.

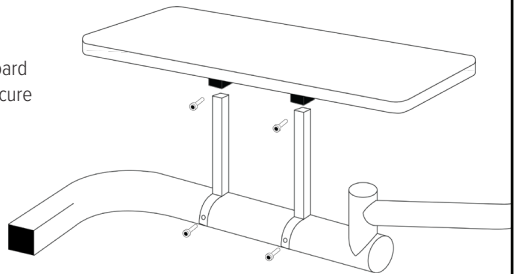



LIMITED WARRANTY

What Is Covered

HitchFire, warrants to the original purchaser that its products listed below are free from defects in material and workmanship, for the term described, except as qualified below. The life of the product is determined from the date of purchase until such time as the product is no longer serviceable due to normal wear and tear.

Steel & Aluminum Castings
All Remaining Parts

When Assembled and operated in accordance with the accompanying printed instructions.

What Is Not Covered

HitchFire shall not be responsible for the natural breakdown of materials that occurs inevitably with extended use (e.g., Ultra Violet (UV) light damage on grill, or defects caused by accident, abuse, alteration, animal attack, storm damage, misuse or improper care, vandalism, improper installation improper maintenance or service, failure to perform normal and routine maintenance, including but not limited to, damage caused by insects within the burner tubes, as set out in this owner's manual warranty section.

Deterioration or damage due to severe weather conditions such as hail, hurricanes, earthquakes, or tornadoes including rust, discoloration due to exposure to chemicals (including salt) either directly or in the atmosphere, or very high humidity, is not covered by this limited Warranty.

THERE ARE NO OTHER EXPRESS WARRANTIES BEYOND THE TERMS OF THIS LIMITED WARRANTY. IN NO EVENT SHALL HitchFire BE LIABLE FOR INCIDENTAL OR CONSEQUENTIAL DAMAGES.

Some states do not allow the exclusion or limitation of incidental or consequential damages, so the above limitation or exclusion may not apply to you.



What HitchFire Will Do

If after inspection we find that a product failed due to a manufacturing or material defect, we will repair or replace the product, at our option, without charge.

How To Obtain Warranty Service

Return the product, freight prepaid, to the HitchFire Dealer from whom it was purchased; or, contact HitchFire Customer Satisfaction Department for return authorization: toll free 1-800-515-5286. Collect shipments or shipments without return authorization cannot be accepted.

REPAIRS

If your HitchFire product needs service or repair due to normal wear and tear, animal attack, accident or some other reason that is not covered under the warranty we will provide the necessary service for a reasonable charge, plus shipping and handling. We require that products accepted for any repair be properly cleaned according to our recommended care instructions. Please send your product that requires repair, postage prepaid, along with a description of what needs attention. For service and repairs, please contact our Customer Satisfaction Department: toll free 1-800-515-5286

How State Law Relates To This Warranty

This warranty gives you specific legal rights, and you may have other rights that vary from state to state.

Warranty Term

Limited two year warranty applies to all components.

IMPORTANT USER/ CONSUMER:

This instruction manual contains important information necessary for the proper assembly and safe use of this appliance. Read and follow all warnings and instructions before assembling and using the appliance.

KEEP THIS MANUAL FOR REFERENCE

HITCH FIRE INC. (DBA HitchFire)

2510 Rosedale Ave.

Soquel, CA 95073

www.hitchfire.com

support@hitchfire.com

1-800-515-5286

[@Hitchfire](#) 