

MORryde Television Mounts

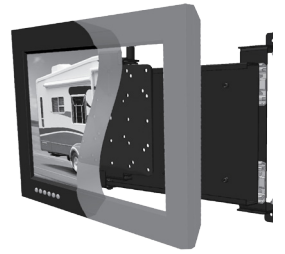

Installation Instructions for TV40-011H

Thank you for choosing a MORryde television mount. The TV40-011H is designed to mount flat panel televisions with VESA (Video Electronics Standards Association) hole patterns up to 200mm x 200mm* and weighing up to 35 lbs. The TV40-011H mounts to a vertical surface or wall, most commonly inside the RV. It can then slide out and swivel up to 180°.

*A 200mm x 400mm adaptor plate is available through MORryde customer service.

CAUTION: The size and weight of your television must be properly supported. The surface must be capable of supporting five times the weight of the television plus the mount. The structure of your RV may require additional reinforcement. MORryde is responsible for the design and manufacturing of our parts; we are not responsible for the structure it is mounted to. Improper installation may cause property damage or personal injury. MORryde cannot be liable for property damage or injury caused by incorrect mounting or incorrect use during travel or otherwise.

This television mount is not intended to be used in the extended or “out” position while the recreation vehicle is in motion.

If you do not understand these directions, or have any doubts about the safety of the installation, please call MORryde customer service at 574-293-1581. Our customer service representatives can assist you with installation questions and missing or replacement parts. Please call MORryde before returning products to the point of purchase.

NOTE: This mount is not intended for use on brick, concrete, or concrete block. It is up to the installer to verify the safety of any installation method or hardware that is not provided by or recommended by MORryde. We make every effort to assure all necessary television mounting hardware is included. If the television mounting hardware you need is not included please consult your local hardware store or call MORryde customer service.

SUPPLIED PARTS AND HARDWARE: Please note that you will not need all of the provided hardware to complete installation.

Hardware for mounting television: Refer to your television’s owners manual or select the appropriate bolt from the hardware provided.

M4



M4 Lock Washer (6)



M4x12mm Bolt (4)



M4x30mm Bolt (4)

M4/M5



#10 Washer (6)

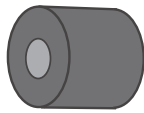

M4/M5 Spacer (4)
Optional*



M5 Lock Washer (6)



M5x30mm Bolt (4)

M6

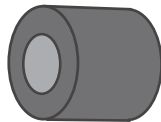

M6 Spacer (4)
Optional*

M5



M5x12mm Bolt (4)



M8x35mm Bolt (4)

M6



M6 Lock Washer (6)



M6x12mm Bolt (4)



M6x35mm Bolt (4)

M8



M8 Lock Washer (6)



M8x12mm Bolt (4)

*Spacers are for televisions with recessed mounting holes.

Hardware for securing bracket: Select the appropriate length based on the thickness of your mounting surface.

< best for metal applications >

< best for wood applications >



1/4" x 1" Self-drilling Screw (8)



1/4" x 1" Lag Bolt (8)



1/4" x 1-1/2" Lag Bolt (8)



1/4" ID Washer (8)

Prepare television for installation: If your television came with a stand, please remove the stand by referring to your television's owners manual and ensure the hardware has been removed from the mounting holes.

STEP 1 Secure the wall bracket to mounting surface:

Pre-drill holes using a 1/8" drill bit for use with 1/4" lag bolts. Use lag bolts or self drilling screws (depending on your mounting surface) with 1/4" washers to secure base of bracket to the mounting surface.

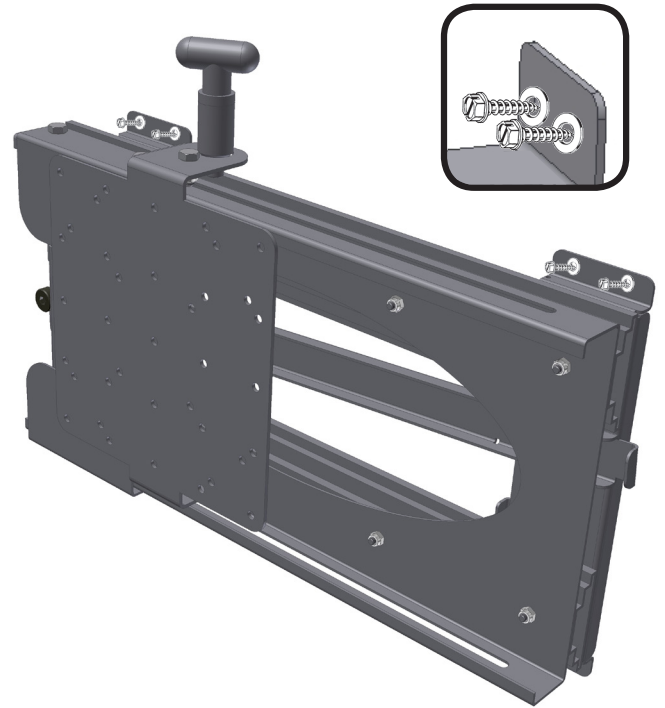

⚠ CAUTION: Using a screw or bolt length that is too long for your application may result in puncturing exterior structure.

STEP 2 Secure the television to mounting plate: Line up the hole pattern on your television with the matching hole pattern on the universal mounting plate as close to the center as possible. Using the appropriate mounting hardware, washers, and optional spacers, secure the television to the mounting plate. This can be done without removing the mounting plate, figures are shown without bracket for illustration purposes only.

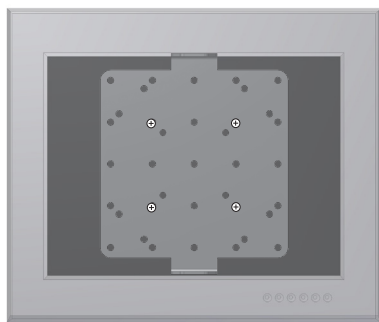
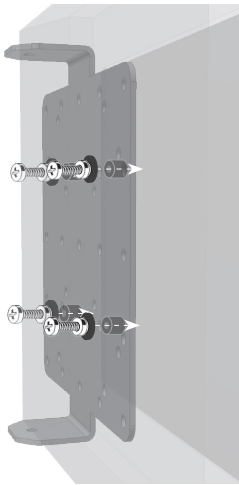

⚠ CAUTION: This step may require two people to lift the television onto the bracket and secure. MOR/ryde is not responsible for property damage and/or personal injury.