

MORryde

Television Mounts



Installation Instructions for TV1-080H

Thank you for choosing a MORryde television mount. The TV1-080H is designed to mount flat panel televisions or monitors with VESA (Video Electronics Standards Association) hole patterns up to 200mm x 200mm and weighing up to 25 lbs.

CAUTION: The size and weight of your television must be properly supported. The surface must be capable of supporting five times the weight of the television plus the mount. The structure of your RV may require additional reinforcement. MORryde is responsible for the design and manufacturing of our parts; we are not responsible for the structure it is mounted to or the construction method used to reinforce the mounting surface. Improper installation may cause property damage or personal injury. MORryde cannot be liable for property damage or injury caused by incorrect mounting or incorrect use during travel or otherwise.

If you do not understand these directions, or have any doubts about the safety of the installation, please call MORryde customer service at 574-293-1581. Our customer service representatives can assist you with installation questions and missing or replacement parts. Please call MORryde before returning products to the point of purchase.

NOTE: This mount is not intended for use on brick, concrete, concrete block, or steel surfaces. It is up to the installer to verify the safety of any installation method or hardware that is not provided by or recommended by MORryde. We make every effort to assure all necessary television mounting hardware is included. If the television mounting hardware you need is not included please consult your local hardware store or call MORryde customer service.

SUPPLIED PARTS AND HARDWARE: Please note that you will not need all of the provided hardware to complete installation.

Hardware for mounting television: Refer to your television's owners manual or select the appropriate bolt from the hardware provided.

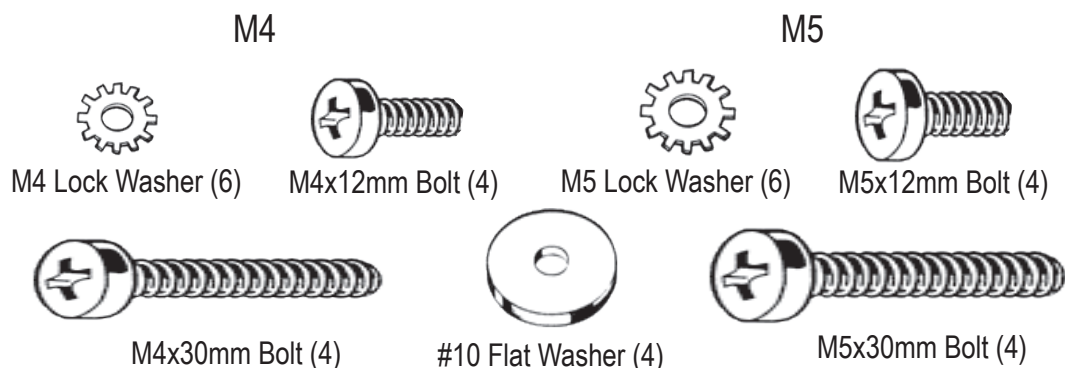

Hardware for securing bracket: Select the appropriate length based on the thickness of your mounting surface.

< best for wood applications >



Prepare television for installation: If your television came with a stand, please remove the stand by referring to your television's owners manual and ensure the hardware has been removed from the mounting holes.

CAUTION: Structure must be reinforced

- the size and weight of your television plus the weight of the mount must be properly supported. MORryde is responsible for the design and manufacturing of our parts; we are not responsible for the structure it is mounted to or the construction method used to reinforce the mounting surface.

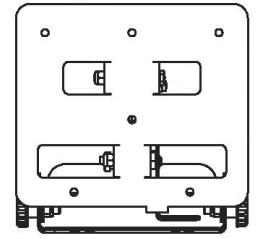
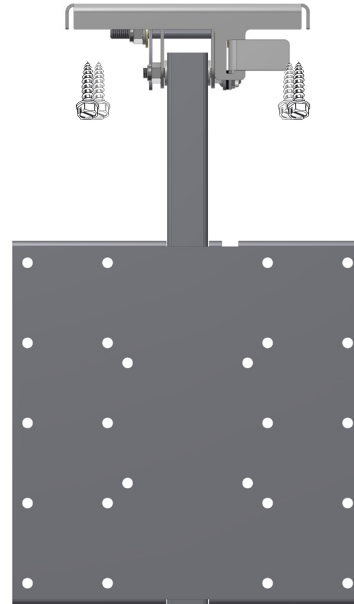

Top view of mounting holes.

STEP 1 Secure mount to reinforced ceiling or mounting surface:

Pre-drill holes using a 1/8" drill bit. Use lag bolts or appropriate hardware for the structure to secure the mount to the reinforced mounting surface.

CAUTION: Using a screw or bolt length that is too long for your application may result in puncturing exterior structure.

STEP 2 Secure the television or monitor to the mount:

Line up the hole pattern on your television with the matching hole pattern on the mounting plate. Using the appropriate mounting hardware and washers, secure the television to the mounting plate.

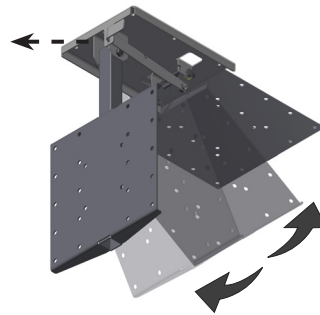
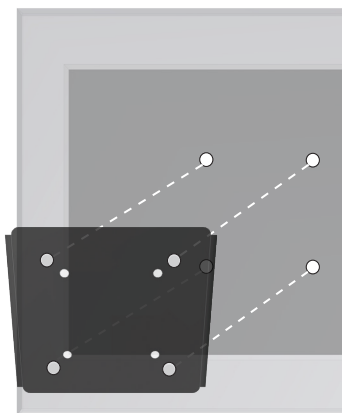
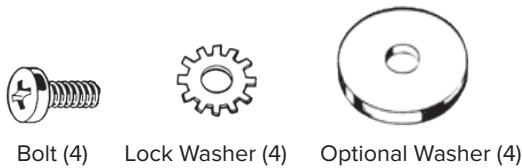

To Flip Down:
While supporting the TV with one hand, pull lever to release lock and gently guide TV into the vertical position.

To Flip Up:
Gently lift TV toward the ceiling and allow it to lock into place.

NOTE: This step may require two people. MORryde is not responsible for property damage and/or personal injury.