

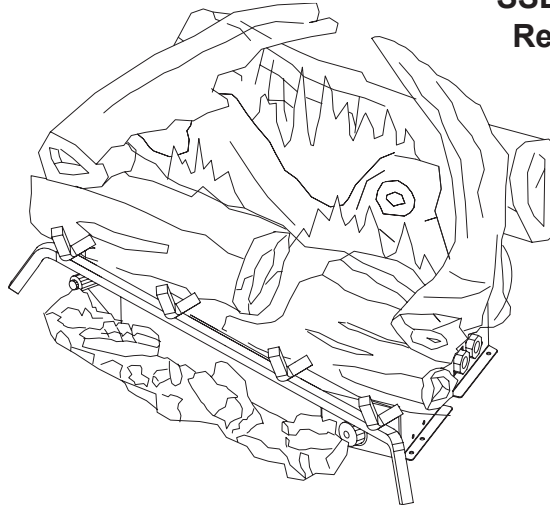

VENT-FREE GAS LOG
MODEL NO. ITEM NO.
SSD18TB 049699
SSD24TA 049801
SSD24TR 050092
SSD30TR 050409
Reverso en español

WARNING: This appliance is equipped for (Natural and Propane) gas. Field conversion is not permitted other than between natural or propane gases.



⚠ CAUTION - FOR YOUR SAFETY

⚠ WARNING: IF THE INFORMATION IN THIS MANUAL IS NOT FOLLOWED EXACTLY, A FIRE OR EXPLOSION MAY RESULT CAUSING PROPERTY DAMAGE, PERSONAL INJURY, OR LOSS OF LIFE.

-- Do not store or use gasoline or other flammable vapors and liquids in vicinity of this or any other appliance.

WHAT TO DO IF YOU SMELL GAS

- Do not try to light any appliance.
- Do not touch any electrical switch; do not use any phone in your building.
- Immediately call your gas supplier from a neighbor's phone. Follow the gas supplier's instructions.
- If you cannot reach your gas supplier, call the fire department.

-- Installation and service must be performed by a qualified installer, service agency or the gas supplier.

This is an unvented gas-fired heater. It uses air (oxygen) from the room in which it is installed. Provisions for adequate combustion and ventilation air must be provided. Refer to *Air For Combustion and Ventilation* section on page 8 of this manual.

INSTALLER: DO NO DISCARD THIS MANUAL – LEAVE FOR HOMEOWNER'S FUTURE REFERENCE

This appliance may be installed in an aftermarket, permanently located manufactured (mobile) home, where not prohibited by local codes. This appliance is for use with the type of gas indicated on the rating plate only. This appliance is not convertible for use with other gases.



Questions about installation, operation, or troubleshooting? Before returning to your retailer, contact our customer service department at 1-866-573-0674, 8:00 a.m.- 4:30 p.m., EST, Monday-Friday, or e-mail customerservice@usaprocom.com.

LS-WYL060-01-0805

TABLE OF CONTENTS

Important Safety Information	3
Air For Combustion and Ventilation	7
Installation	10
Operation.....	23
Care And Maintenance	30
Troubleshooting	31
Replacement Parts	34

⚠ WARNING: READ THE INSTALLATION & OPERATION INSTRUCTIONS BEFORE USING THIS APPLIANCE

IMPORTANT: Read instructions and warnings carefully before starting installation. Failure to follow these instructions may result in a possible fire hazard and will void the warranty.

PRODUCT SPECIFICATIONS

ITEM NO.	18 IN. VENT-FREE GAS LOGS		24 IN. VENT-FREE GAS LOGS	
Input Rating	30,000 BTU/Hr	30,000 BTU/Hr	32,000 BTU/Hr	32,000 BTU/Hr
Gas Type	Natural	LP/Propane	Natural	LP/Propane
Ignition	Electronic Piezo	Electronic Piezo	Electronic Piezo	Electronic Piezo
Manifold Pressure	4 in. W.C	9 in. WC.	4 in. W.C	9 in. WC.
Inlet Gas Pressure	*For purposes of input adjustment			
Maximum	10.5 in. W.C	14 in. W.C	10.5 in. W.C	14 in. W.C
Minimum*	5 in. W.C	11 in. W.C	5 in. W.C	11 in. W.C
ITEM NO.	24 IN. VENT-FREE GAS LOGS		30 IN. VENT-FREE GAS LOGS	
Input Rating	34,000 BTU/Hr	34,000 BTU/Hr	39,000 BTU/Hr	39,000BTU/Hr
Gas Type	Natural	LP/Propane	Natural	LP/Propane
Ignition	Electronic Piezo	Electronic Piezo	Electronic Piezo	Electronic Piezo
Manifold Pressure	4 in. W.C	9 in. WC.	4 in. W.C	9 in. WC.
Inlet Gas Pressure	*For purposes of input adjustment			
Maximum	10.5 in. W.C	14 in. W.C	10.5 in. W.C	14 in. W.C
Minimum*	5 in. W.C	11 in. W.C	5 in. W.C	11 in. W.C

IMPORTANT SAFETY INFORMATION

IMPORTANT: Read this owner's manual carefully and completely before trying to assemble, operate, or service this heater. Improper use of this heater can cause serious injury or death from burns, fire, explosion, electrical shock, and carbon monoxide poisoning.

WHAT TO DO IF YOU SMELL GAS

- Do not try to light any appliance.
- Do not touch any electrical switch; do not use any phone in your building.
- Immediately call your gas supplier from a neighbor's phone. Follow the gas supplier's instructions.
- If you cannot reach your gas supplier, call the fire department.

Installation and service must be performed by a qualified installer, service agency, or local gas supplier.

 **WARNING:** Do not store or use gasoline or other flammable vapors or liquids in the vicinity of this or any other appliance.

This appliance is for use with only the type of gas indicated on the rating plate. This appliance is not convertible for use with other gases.

CARBON MONOXIDE POISONING: Early signs of carbon monoxide poisoning resemble the flu, with headaches, dizziness, or nausea. If you have these signs, the heater may not be working properly. **Get fresh air immediately!** Have heater serviced. Some people are more affected by carbon monoxide than others. These include pregnant women, persons with heart or lung disease or anemia, those under the influence of alcohol, and those at high altitudes.

NATURAL AND PROPANE/LP GAS: Natural or propane/LP gas is odorless. An odor-producing agent is added to natural or propane/LP gas. The odor helps you detect a natural or propane/LP gas leak. However, the odor added to natural or propane/LP gas can fade. Natural or propane/LP gas may be present even though no odor exists. Make certain you read and understand all warnings. Keep this manual for reference. It is your guide to safe and proper operation of this heater.

 **WARNING:** Do not use a blower insert, heat exchanger insert or any accessory not approved for use with this log set.

 **WARNING:** Do not allow fans to blow directly into the heater. Avoid any drafts that alter burner flame pattern including ceiling fans. Altered burner patterns can cause sooting.

 **WARNING:** Any change to this heater or its controls can be dangerous.

 **WARNING:** Do not place clothing or other flammable material on or near the appliance. Never place any objects in or on the fireplace.

 **WARNING:** Due to high temperatures, place the log set of traffic and away from furniture and draperies.

 **WARNING:** The log set becomes very hot while running heater. Keep children and adults away from the hot surface to avoid burns or clothing ignition. Heater will remain hot for a short time after shut off. Allow surface to cool before touching.

 **WARNING:** Carefully supervise young children when they are in the same room with the heater.

 **WARNING:** Make sure a fireplace screen is in place before running the log set.

 **WARNING:** Do not install in bedrooms or bathrooms.

 **WARNING:** Keep the appliance area clear and free from combustible materials, gasoline, and other flammable vapors and liquids.

1. This appliance is for use with only the type of gas indicated on the rating plate. This appliance is not convertible for use with other gases.
2. Do not place propane/LP supply tank(s) inside any structure. Store propane/LP supply tank(s) outdoors.
3. This heater should not be installed in a bedroom or bathroom unless installed as a vented appliance.
4. Solid fuels should not be burned in a fireplace in which vent-free log set is installed.
5. Do not add extra logs or ornaments such as pine cones, vermiculite, or rock wool. Using these added items can cause sooting. Do not add lava rock around base. Rock and debris could fall into the control area of heater. After servicing, always replace screen before operating heater.
6. If fireplace has glass doors, never operate this heater with glass doors closed. If you operate heater with doors closed, heat will build up inside fireplace and cause glass to burst. If fireplace opening has vents at the bottom, you must open the vents before operating log set. Always operate heater with glass doors fully open.
7. This log heater is designed to be smokeless. If logs ever appear to be smoking, turn off heater and call a qualified service technician. **NOTE:** During initial operating, slight smoking could occur due to log curing and heater burning off manufacturing residues.
8. To prevent the creation of soot, follow the instructions (see *Care and Maintenance* page 30).
9. Before using furniture polish, wax, carpet cleaner, or similar products, turn heater off. If heated, the vapor from these products may create a white powder residue within burner box or on adjacent walls and furniture.
10. This heater needs fresh, outside air ventilation to run properly. This heater has an Oxygen Depletion Sensor (ODS) safety shutoff system. The ODS shuts down the heater if not enough fresh air is available. (See *Air For Combustion And Ventilation*, pages 7-9)

11. Do not run heater where flammable liquids or vapors are used or stored under dusty conditions.
12. Turn off heater before using furniture polish, wax, carpet cleaner, or similar products.
13. Do not use heater if any part has been underwater. Immediately call a qualified service technician to inspect the room heater and replace any part of the control system and any gas control which has been underwater.
14. Turn off and let cool before servicing. Only a qualified service technician should service and repair heater.
15. Operating heater above elevations of 4,500 feet could cause pilot outage.
16. Do not use this heater if any log is broken. Do not operate heater if a log is chipped (dime-size or larger).
17. Do not use this heater to cook food or burn paper or other objects.

QUALIFIED INSTALLING AGENCY

Installation and replacement of gas piping, gas utilization equipment or accessories and repair and servicing of equipment should be performed only by a qualified agency. The term "qualified agency" means any individual, firm, corporation, or company that either in person or through a representative is engaged in and is responsible for:

- a) The installation, testing, or replacements of gas piping or
- b) The connection, installation, testing, repair, or servicing of equipment; that is experienced in such work; that is familiar with all precautions required; and that has complied with all the requirement of the authority having jurisdiction.

In areas that prohibit the use of vent-free heaters, the log set has been tested and approved to the ANSI Z21.60 standard for Vented Decorative Logs.

PRODUCT FEATURES:

This log set has been tested and approved to ANSI Z21.11.2 standard for Unvented Heaters and can be operated with the flue damper closed. State and local codes in some areas prohibit the use of vent-free heaters.

SAFETY PILOT

This heater has a pilot with an Oxygen Depletion Sensing (ODS) safety shutoff system. The ODS/pilot shuts off the heater if there is not enough fresh air.

THERMOSTAT HEAT CONTROL

The control automatically cycles the burner on and off to maintain a desired room temperature. See page 25.

PIEZO IGNITION SYSTEM

This heater is equipped with an electronic piezo ignitor. This system requires AAA batteries (provided).

CAUTION: Do not remove the metal data plates from the grate assembly. The data plates contain important product information.

2 FUEL OPTIONS CAPABLE

Your log heater is equipped to operate on either propane or natural gas. The fireplace is shipped from the factory ready for connecting to propane. The fireplace can easily be changed to natural gas by having your qualified installer follow the instructions on page 18 and the markings on the fireplace.

LOCAL CODES

Install and use heater with care. Follow all local codes. In the absence of local codes, use the latest edition of *The National Fuel Gas Code, ANSI Z223.1/NFPA 54*.

*Available from:

American National Standards Institute, Inc.
1430 Broadway
New York, NY 10018

National Fire Protection Association, Inc.
1 Batterymarch Park
Quincy, MA 02269-9101

State of Massachusetts: The installation must be made by a licensed plumber or gas fitter in the Commonwealth of Massachusetts. Sellers of unvented propane or natural gas-fired supplemental room heaters shall provide to each purchaser a copy of 527 CMR 30 upon sale of the unit. In the state of Massachusetts, unvented propane or natural gas-fired space heaters shall be prohibited in bedrooms and bathrooms.

In the State of Massachusetts the gas cock must be a "T" handle type. The State of Massachusetts requires that a flexible appliance connector cannot exceed three feet in length.

PREPARING FOR INSTALLATION

Before beginning assembly or operation of the product, make sure all parts are present. Compare parts with package contents list and diagram above. If any part is missing or damaged, do not attempt to assemble, install or operate the product. Contact customer service for replacement parts.

Estimated Assembly Time: 1 to 2 hours

Tools Required for Assembly:

Before installing heater, make sure you have the the following:

- Hardware package (provided with heater)
- Approved flexible gas hose (not provided) if allowed by local codes
- Sealant (resistant to natural or propane/LP gas, not provided)
- Electric drill with 3/16- in. drill bit
- Phillips screwdriver
- External regulator (supplied by installer)
- Piping (check local codes)
- Equipment shutoff valve
- Test gauge connection
- Sediment trap
- Tee joint
- Pipe wrench

UNPACKING

1. Remove logs and burner base assembly from carton. **NOTE:** Do not pick up burner base assembly by burners as this could damage heater. Always handle base assembly by grate.
2. Remove all protective packaging applied to logs and heater for shipment.
3. Check all items for any shipping damage. If damaged, promptly inform dealer where you purchased the heater.

WATER VAPOR: A BY-PRODUCT OF UNVENTED ROOM HEATERS

Water vapor is a by-product of gas combustion. An unvented room heater produces approximately one (1) ounce (30 mL) of water for every 1,000 BTUs (.3KW) of gas input per hour. Unvented room heaters are recommended as supplemental heat (a room) rather than a primary heat source (an entire house). In most supplemental heat applications, the water vapor does not create a problem. In most applications, the water vapor enhances the low humidity atmosphere experienced during cold weather.

The following steps will help insure that water vapor does not become a problem:

1. Be sure the heater is sized properly for the application, including ample combustion air and circulation air.
2. If high humidity is experienced, a dehumidifier may be used to help lower the water vapor content of the air.
3. Do not use an unvented room heater as the primary heat source.

AIR FOR COMBUSTION AND VENTILATION

⚠ WARNING: This heater shall not be installed in a confined space or unusually tight construction unless provisions are provided for adequate combustion and ventilation air. Read the following instructions to ensure proper fresh air for this and other fuel-burning appliances in your home.

PRODUCING ADEQUATE VENTILATION

The following are excerpts from *National Fuel Gas Code, NFPA 54/ANS Z223.1. Air for Combustion and Ventilation*. All spaces in homes fall into one of the three following ventilation classifications:

1. Unusually Tight Construction
2. Unconfined Space
3. Confined Space

The information on pages 7 through 9 will help you classify your space and provide adequate ventilation.

Confined and Unconfined Space

The National Fuel Gas Code, ANS Z223.1 defines a confined space as a space whose volume is less than 50 cu. ft. per 1,000 BTU/hr (4.8 m³ per kw) of the aggregate input rating of all appliances installed in that space and an unconfined space as a space whose volume is not less than 50 cu. ft. per 1,000 BTU/hr (4.8 m³ per kw) of the aggregate input rating of all appliances installed in that space. Rooms communicating directly with the space in which the appliances are installed*, through openings not furnished with doors, are considered a part of the unconfined space.

This heater shall not be installed in a confined space or unusually tight construction unless provisions are provided for adequate combustion and ventilation air.

* Adjoining rooms are connecting only if there are doorless passageways or ventilation grills between them.

Unusually Tight Construction

The air that leaks around doors and windows may provide enough fresh air for combustion and ventilation. However, in buildings of unusually tight construction, you must provide additional fresh air.

Unusually tight construction is defined as construction where:

- a) walls and ceilings exposed to the outside atmosphere have a continuous water vapor retarder with a rating of one perm (6×10^{-11} kg per pa-sec- m^2) or less with openings gasketed or sealed and
- b) Weather stripping has been added on openable windows and on doors and
- c) Caulking or sealants are applied to areas such as joints around window and door frames, between sole plates and floors, between wall ceiling joints, between wall panels, at penetrations for plumbing, electrical, and gas lines, and at other openings.
- d) If your home meets all of the three criteria above, you must provide additional fresh air. See "Ventilation Air From Outdoors". If your home does not meet all of the three criteria above, proceed to "Determining Fresh-Air Flow For Heater Location".

DETERMINING FRESH-AIR FLOW FOR HEATER LOCATION

Determining if You Have a Confined or Unconfined Space

Use this worksheet to determine if you have a confined or unconfined space.

Space: Includes the room in which you will install heater plus any adjoining rooms with doorless passageways or ventilation grills between the rooms.

1. Determine the volume of the space

Length \times Width \times Height = _____ cu. ft. (volume of space)

Example: Space size 20 ft. (length) \times 16 ft. (width) \times 8 ft. (ceiling height) = 2560 cu. ft. (volume of space)

If additional ventilation to adjoining room is supplied with grills or openings, add the volume of these rooms to the total volume of the space.

2. Divide the space volume by 50 cubic feet to determine the maximum BTU/hr the space can support.

_____ (volume of space) \div 50 cu. ft. = (Maximum BTU/hr the space can support)

3. Add the BTU/hr of all fuel burning appliances in the space.

Vent-free heater

Gas water heater* _____ BTU/hr

Gas furnace _____ BTU/hr

Vented gas heater _____ BTU/hr

Gas heater logs _____ BTU/hr

Other gas appliances* + _____ BTU/hr

Total = _____ BTU/hr

_____ BTU/hr

Example:

Gas water heater 40,000 BTU/hr

Vent-free heater + 31,500 BTU/hr

Total = 71,500 BTU/hr

*Do not include direct-vent gas appliances. Direct-vent draws combustion air from the outdoors and vents to the outdoors.

4. Compare the maximum BTU/hr the space can support with the actual amount of BTU/hr used

_____ BTU/hr (maximum the space can support)

_____ BTU/hr (actual amount of BTU/hr used)

Example : 51,200 BTU/hr(maximum the space can support)

71,000 BTU/hr(actual amount of BTU/hr used)

The space in the above example is a confined space because the actual BTU/hr used is more than the maximum BTU/hr the space can support. You must provide additional fresh air. Your options are as follows:

- a) Rework worksheet, adding the space of an adjoining room. If the extra space provides an unconfined space, remove door to adjoining room or add ventilation grills between rooms. See "Ventilation Air From Inside Building", page 9.
- b) Vent room directly to the outdoors. See "Ventilation Air From Outdoors", page 9.
- c) Install a lower BTU/hr heater, if lower BTU/hr size makes room unconfined. If the actual BTU/hr used is less than the maximum BTU/hr the space can support, the space is an unconfined space. You will need no additional fresh air ventilation.

⚠ NOTE: If the area in which the heater may be operated is smaller than that defined as an unconfined space or if the building is of unusually tight construction, provide adequate combustion and ventilation air by one of the methods described in the *National Fuel Gas Code, ANS Z223.1/NFPA. Air for combustion and ventilation or applicable local codes.*

Ventilation Air From Inside Building

This fresh air would come from adjoining unconfined space. When ventilating to an adjoining unconfined space, you must provide two permanent openings: one within 12 inches of the wall connecting the two spaces (see options 1 and 2, Figure 1). You can also remove door into adjoining room (see option 3, Figure 2). Follow the National Fuel Gas Code NFPA 54/ANS Z223.1. *Air for Combustion and Ventilation* for required size of ventilation grills or ducts.

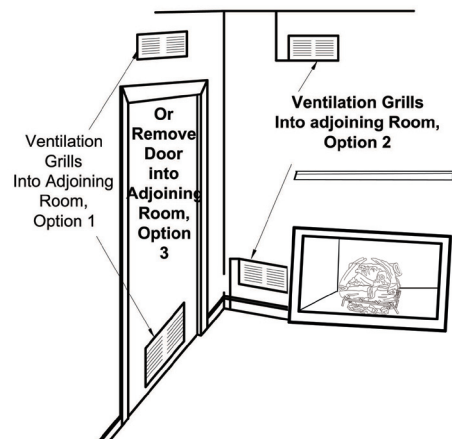

Figure 1 - Ventilation Air from Inside Building

Ventilation Air From Outdoors

Provide extra fresh air by using ventilation grills or duct. You must provide two permanent openings: one within 12 inches of the ceiling and one within 12 inches of the floor. Connect these items directly to the outdoors or spaces open to the outdoors. These spaces include attics and crawl spaces. Follow the National Fuel Gas Code NFPA 54/ANS Z223.1., *Air for Combustion and Ventilation* for required size of ventilation grills or ducts.

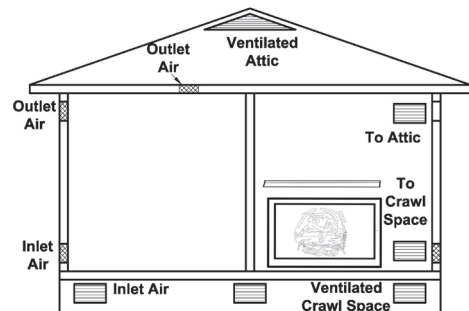

Figure 2 - Ventilation Air from Outdoors

⚠ IMPORTANT: Do not provide openings for inlet or outlet air into attic if attic has a thermostat controlled power vent. Heated air entering the attic will activate the power vent. Rework worksheet, adding the space of the adjoining unconfined space. The combined spaces must have enough fresh air to supply all appliances in both spaces.

INSTALLATION

⚠ NOTICE: This heater is intended for use as supplemental heat. Use this heater along with your primary heating system. Do not install this heater as your primary heat source. If you have a central heating system you may run the system's circulating blower while using the heater. This will help circulate the heat throughout the house. In the event of power outage, you can use this heater as your primary heat source.

⚠ WARNING: A qualified technician must install heater. Follow all local codes.

⚠ WARNING: Before installing in a solid flue burning firebox, the chimney flue and firebox must be cleaned of soot, creosote, ashes and loose paint by a qualified chimney cleaner. Creosote will ignite if highly heated. A dirty chimney flue may create and distribute soot within the house. Inspect chimney flue for damage.

⚠ WARNING: Maintain the minimum clearances. If possible, provide greater clearances from the floor, ceiling, and adjoining wall than required.

Minimum Fireplace Clearance to Combustible Materials		
Log size	Side wall	Ceiling
18 in., 24 in., 30 in.	16 in.	42 in.

⚠ WARNING: Seal any fresh air vents or ash clean-out doors located on the floor or wall of fireplace to prevent drafting caused by pilot outage or sooting. Use a heat-resistant sealant. Do not seal chimney flue damper.

⚠ CAUTION: This heater creates warm air currents. These currents move heat to wall surface next to heater. Installing heater next to vinyl or cloth wall coverings or operating heater where impurities (such as tobacco smoke, aromatic candles, cleaning fluids, oil or kerosene lamps, etc.) in the air exist may discolor walls.

⚠ NOTICE: State or local codes may only allow operation of this appliance in a vented configuration. Check your state or local codes.

⚠ IMPORTANT: Vent-free heaters add moisture to the air. Although this is beneficial, installing heater in rooms without enough ventilation air may cause mildew to form from too much moisture. See *Air for Combustion and Ventilation*, pages 8 through 10.

CHECK GAS TYPE

Make sure your gas supply is correct for your log set. If supply is not correct, do not install heater. Call dealer where you purchased heater for proper gas log set.

LOG SIZING REQUIREMENTS				
Log Size	Minimum Firebox Size			
	Height	Depth	Front Width	Rear Width
SSD18TB	20 in.	13 in.	29 in.	23 in.
SSD24TA	20 in.	14 in.	30 in.	22 in.
SSD24TR	20 in.	14 in.	30 in.	22 in.
SSD30TR	20 in.	14 in.	34 in.	24 in.

⚠ WARNING: This appliance is designed for installation in only a solid-fuel burning masonry or UL 127 factory-built fireplace or in a listed ventless firebox enclosure. Exception: DO NOT install this appliance in a factory-built fireplace that includes instructions stating it has not been tested or should not be used with unvented gas logs.

**MINIMUM CLEARANCE FOR SIDE
Combustible Material, Side Wall, and Ceiling.**

- A. Clearance from the side of the fireplace opening to any combustible material and wall should follow diagram in Figure 3.
- B. Clearance from the top of the fireplace opening to the ceiling must not be less than 42 inches.

**MINIMUM NONCOMBUSTIBLE MATERIAL CLEARANCE
If Not Using Mantel**

You must have noncombustible material(s) above the fireplace opening. Noncombustible materials (such as slate, marble, tile, etc.) must be at least 1/2 in. thick. With sheet metal, you must have noncombustible material behind it, such as a noncombustible fireplace hood accessory. See Figure 5 next page for minimum clearance requirements.

⚠ NOTICE: This heater may be used as a vented product. If so, you must always operate log set with chimney flue damper open. If running log set with damper open, noncombustible material above fireplace opening is not needed. Go to *Installing Damper Clamp Accessory for Vented Operation*, page 13.

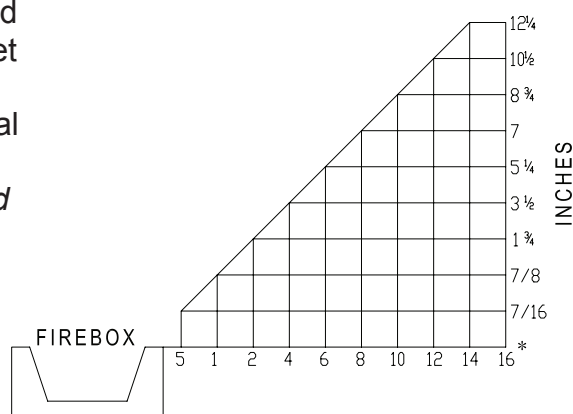

Figure 3 - Minimum Clearance for Combustible to Wall

If Using Mantel

You must have noncombustible material(s) (such as slate, marble, tile, etc.) at least 1/2 in. thick. With sheet metal, you must have noncombustible material behind it. Noncombustible material must extend at least 8 inches up. If noncombustible material is less than 12 in., you must install the fireplace hood accessory. Even if noncombustible material is more than 12 in., you may need the hood accessory to deflect heat away from mantel shelf. See Figures 4, 5 and 6 for minimum clearances requirements.

⚠ IMPORTANT: If these minimum clearances are not met, you must operate heater with chimney flue damper open. Go to “Installing Damper Clamp Accessory for Vented Operation,” page 13.

MANTEL CLEARANCES

In addition to meeting noncombustible material clearances, you must also meet required clearances between fireplace opening and mantel shelf. If the clearances listed below are not met, you will need a hood.

Determining Mantel Clearances

If you meet minimum clearance requirements between mantel shelf and top of fireplace opening, a hood is not necessary (see Figure 5).

Noncombustible Material Distance	Requirements for Safe Installation
8 inches or more	Noncombustible material okay.
Less than 8 inches	Noncombustible material must be extended to at least 8 inches and 12 inches above. If you can not extend material, you must operate heater with flue damper open.

Determining Minimum Mantel Clearance When Using a Hood

If minimum clearances in Figure 6 are not met, you must have a hood. When using a hood there are still certain minimum mantel clearances required. Follow minimum clearances shown in Figure 6 when using a hood.

⚠ NOTICE: Surface temperature of adjacent walls and mantels become hot during operation. Walls and mantels above the firebox may become too hot to touch. If installed properly, these temperatures meet the requirement of the national product standard. Follow all minimum clearances shown in this manual.

⚠ NOTICE: If your installation does not meet the minimum clearances shown, you must do one of the following: Operate the logs with the flue damper open only. Raise the mantel to an acceptable height.

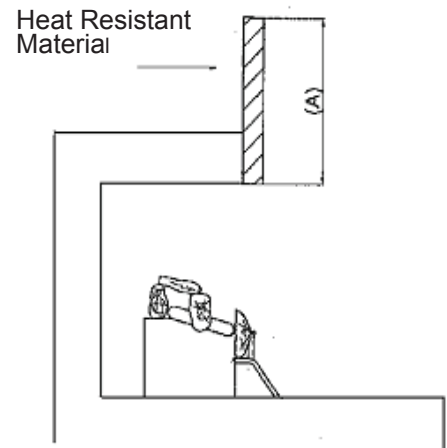

Figure 4 - Heat resistant material (slate, marble, tile, etc.) above fireplace

FLOOR CLEARANCES

- If installing appliance on floor level, you must maintain the minimum distance of 14 inches to combustibles (see Figure 7).
- If combustible materials are less than 14 inches to the fireplace, you must install appliance at least 5 inches above the combustible flooring (see Figure 8).

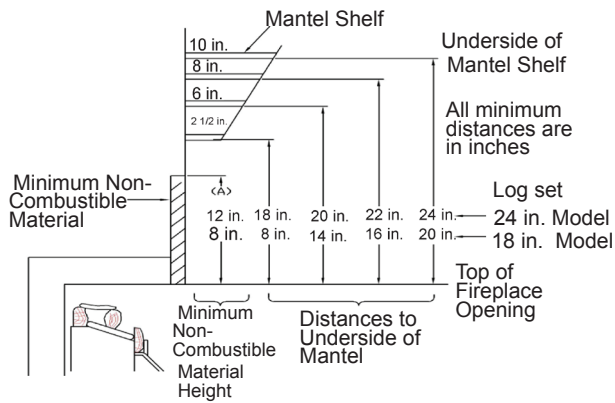

Figure 5 - Minimum mantel clearances without using hood

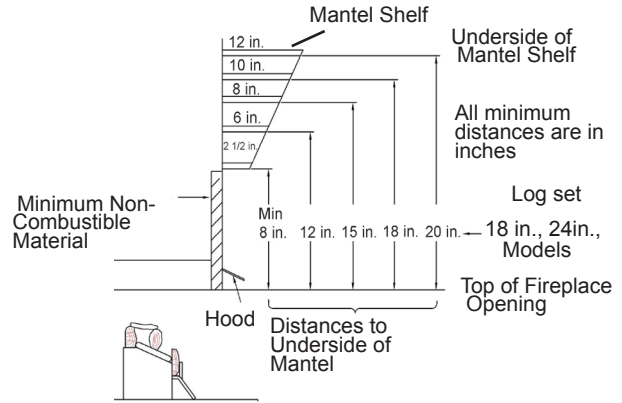

Figure 6 - Minimum mantel clearances when using hood

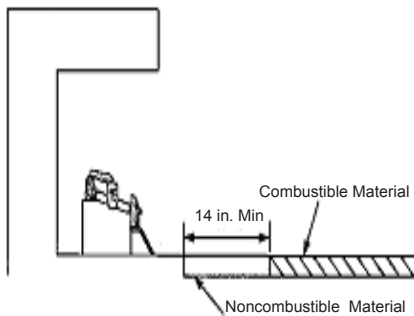

Figure 7- Minimum fireplace clearances if installed at floor level

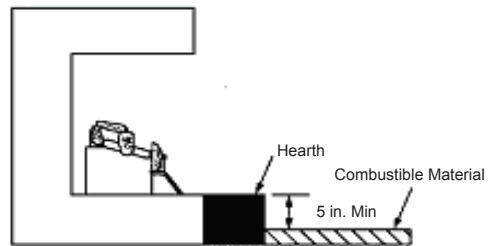

Figure 8 - Minimum fireplace clearances above combustible flooring

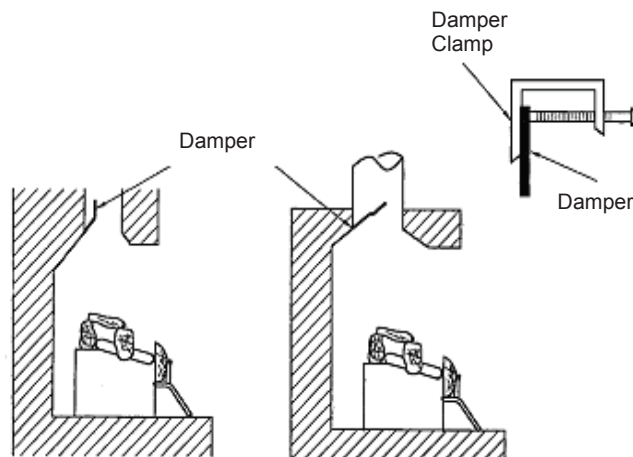

Figure 9 - Attach Damper to Fireplace

INSTALLING DAMPER CLAMP ACCESSORY FOR VENTED OPERATION

NOTE: When used as a vented heater, appliance must be installed only in a solid-fuel burning fireplace with a working flue constructed of noncombustible material. You may use this heater as a vented product. There are three reasons for operating your heater as a vented model:

1. The fireplace does not meet the clearance requirements for vent-free operation.
2. State or local codes do not permit vent-free operation.
3. You prefer vented operation.

If reasons number 1 or 2 above apply to you, you must permanently open chimney flue damper. You must install the damper clamp accessory (not provided). This will ensure vented operation (see Figure 9). The damper clamp will keep damper open. Installation instructions are included with clamp accessory.

See chart below for the minimum permanent flue opening you must provide. Attach damper clamp so the minimum permanent opening will be maintained at all times.

Chimney Height (ft.)	Minimum Permanent Flue Opening (sq. in)
6 ft to 15 ft	39 sq. in.
15 ft to 30 ft	29 sq. in.

Area of Various Standard Round Flues	
Diameter (in.)	Area (sq. in.)
5 in.	20 sq.in.
6 in.	29 sq.in.
7 in.	39 sq in.
8 in.	51 sq in.

INSTALLING HEATER BASE ASSEMBLY

CAUTION: Do not remove the metal data plates attached to the heater base assembly. The data plates contain important warranty information.

WARNING: You must secure this heater to fireplace floor. If not, heater will move when you adjust controls. Moving heater may cause a gas leak.

WARNING: If installing in sunken fireplace, special care is needed. You must raise the fireplace floor to allow access to heater control panel. This will insure adequate air flow and guard against sooting. Raise fireplace floor with noncombustible material.

CAUTION: Do not pick up heater base assembly by the burner. This could damage heater. Handle base assembly only by grates.

IMPORTANT: Make sure the heater burners are level. If heater is not level, heater will not work properly. Avoid damage to thermostat bulb. Avoid nicks or sharp bends in thermostat bulb wire. Keep thermostat bulb in mounting bracket.

CONNECTING TO GAS SUPPLY

⚠ WARNING: A qualified service technician must connect heater to gas supply. Follow all local codes.

⚠ WARNING: This appliance requires 1/2-inch NPT (National Pipe Thread) inlet connection to the pressure regulator.

⚠ WARNING: Never connect heater to private (non-utility) gas wells. This is commonly known as well-head gas.

⚠ CAUTION: Never connect heater directly to the natural or propane/LP supply. This heater requires an external regulator (not supplied). Install the external regulator between the heater and natural or propane/LP supply.

1. Apply pipe joint sealant lightly to fitting threads. Connect approved flexible gas hose to gas regulator of heater (see Figure 11).

NOTE: Never apply pipe sealant to flare fitting threads.

⚠ IMPORTANT: Hold gas regulator with wrench when connecting flexible gas hose.

2. Locate masonry screws in hardware package.
3. Position heater base assembly in fireplace.
4. Place logs in their proper position on heater base.
5. Center heater base and logs front-to-front and side-to-side in fireplace.
6. Carefully remove logs without moving heater base.
7. Mark screw locations through holes in mounting brackets (see Figure 11). If installing in a brick-bottom fireplace, mark screw locations in mortar joint of bricks.
8. Remove heater base from fireplace.
9. Drill holes at marked locations using 3/16-inch drill bit.
10. Attach base assembly to fireplace floor using two masonry screws (in hardware package) (see Figure 10).

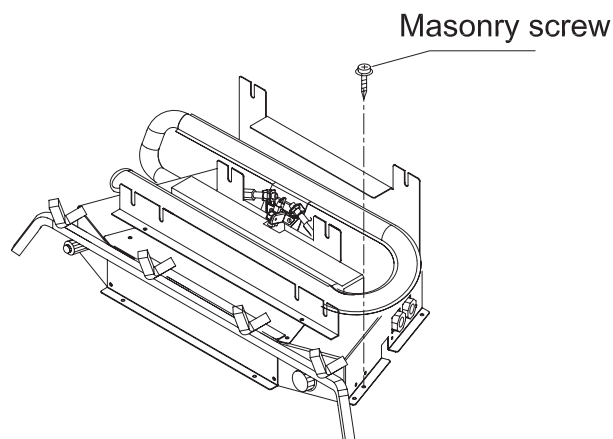

Figure 10 - Attaching Heater Base to Fireplace Floor

A CSA/AGA design-certified equipment shutoff valve with 1/8-inch NPT tap is an acceptable alternative to test gauge connection. Purchase the optional CSA/AGA design-certified equipment shutoff valve from your dealer.

The installer must supply an external regulator. The external regulator will reduce incoming gas pressure. You must reduce incoming gas pressure to minimum allowable on rating label. If you do not reduce incoming gas pressure, heater regulator damage could occur. Install external regulator with the vent down as shown in Figure 12. Pointing the vent down protects it from freezing rain or sleet.

Installation must include equipment shutoff valve, union, and plugged 1/8-inch NPT tap. Locate NPT tap within reach for test gauge hook up. NPT tap must be upstream from heater (see Figure 13). To prevent performance problems, Propane/LP tank of less than 100 lb. capacity is not recommended.

⚠ IMPORTANT: Install an equipment shutoff valve in an accessible location. The equipment shutoff valve is for turning on or shutting off the gas to the appliance. Apply pipe joint sealant lightly to male threads. This will prevent excess sealant from going into pipe. Excess sealant in pipe could result in clogged heater valves.

⚠ CAUTION: Use only a new, black iron or steel pipe. Internally-tinned copper tubing may be used in certain areas. Check your local codes. Use pipe of large enough diameter to allow proper gas volume to heater. If pipe is too small, undue loss of pressure will occur.

⚠ CAUTION: Use pipe joint sealant that is resistant to natural gas (NG) or liquid petroleum (LP) gas.

We recommend that you install a sediment trap in the supply line as shown in Figure 13. Place sediment trap where it is within reach for cleaning and where trapped matter is not likely to freeze. A sediment trap traps moisture and contaminants. This keeps them from going into heater controls. If sediment trap is not installed or is installed incorrectly, heater may not run properly.

⚠ IMPORTANT: Hold pressure regulator with wrench when connecting it to gas piping and/or fittings.

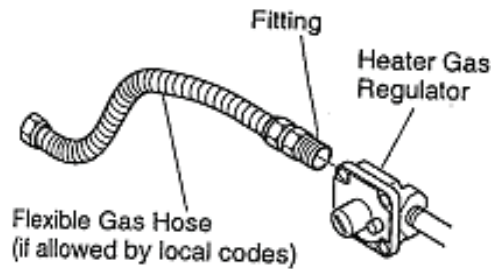

Figure 11 - Attaching Flexible Gas Hose to Heater Gas Regulator

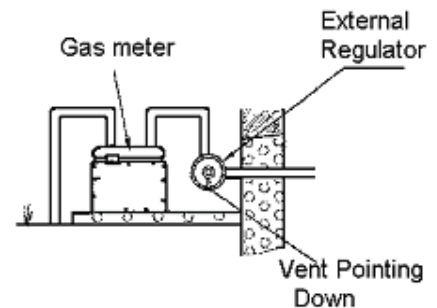

Figure 12-A - External Regulator with Vent Pointing Down For NG

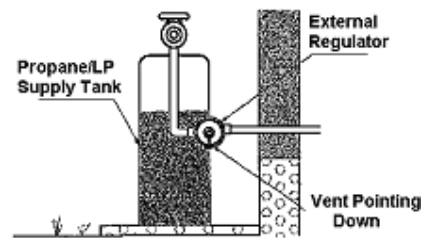

Figure 12-B - External Regulator with Vent Pointing Down For LP

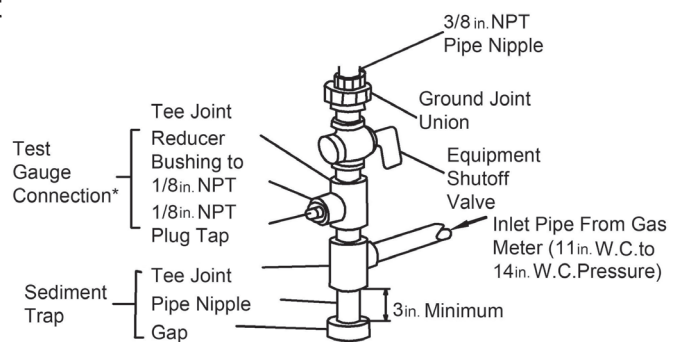



Figure 13 - Gas Connection

CAUTION: Two gas line installation at the same time is forbidden.

Heater is pre-set at factory for propane gas, no changes are required for connecting to propane. Only a qualified installer or service technician can perform gas selection and connecting to gas supply.

For changing from propane to natural gas supply:

1. Overturn chassis, See Figure 14.
2. For NATURAL GAS, press knob using a flat screwdriver with a blade the thickness of a quarter and turn knob clockwise  until the knob locks into the NG position (see Figure 15). Selection valve must be locked in the NG position. Do not operate heater between locked positions!
3. Remove hex plug (with wrench provided) from natural gas inlet of regulator and install into LP inlet of regulator; use thread sealant to assure there are no leaks.

CAUTION: To avoid gas leakage at the inlet of regulator, a qualified installer or service technician must use hex plug with sealant.

For changing from natural gas supply to propane supply:

1. Overturn chassis, See Figure 14.
2. For propane gas, press in knob using a flat screwdriver with a blade the thickness of a quarter and turn knob counterclockwise  until the knob locks into the LP position, see Figure 16. Selection valve must be locked in the LP position. Do not operate heater between locked positions.
3. Remove hex plug from liquid propane inlet of regulator and install into NG inlet of regulator; use thread sealant to assure there are no leaks.

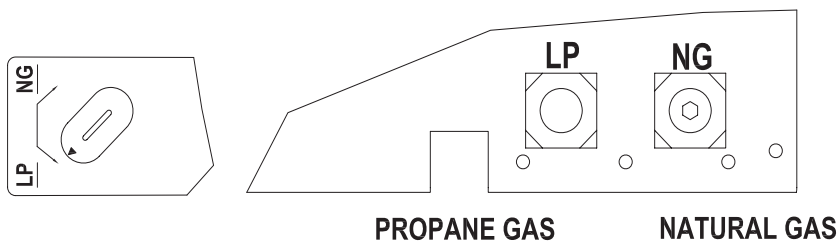

Figure 14

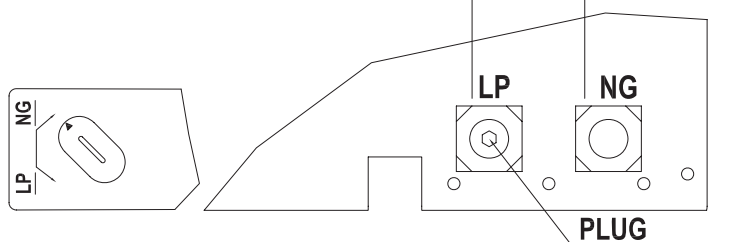

Figure 15

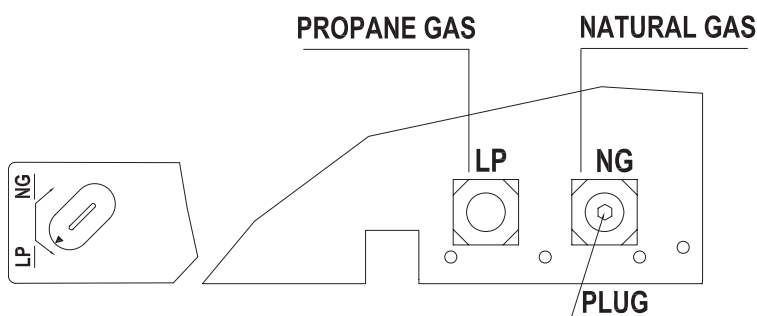

Figure 16

CHECKING GAS CONNECTIONS

⚠ WARNING: Test all gas piping and connections for leaks after installing or servicing. Never use an open flame to check for leaks. Apply a mixture of liquid soap and water to all joints. Bubbles forming indicate a leak. Correct all leaks immediately.

Pressure Testing Gas Supply Piping System

Test Pressure in Excess Of 1/2 PSIG (3.5 K Pa)

1. Disconnect appliance with its appliance main gas valve (control valve) and equipment shutoff valve from gas supply piping system. Pressure in excess of 1/2 psig will damage heater regulator.
2. Cap off open end of gas pipe where equipment shutoff valve was connected.
3. Pressurize supply piping system by either using compressed air or opening main gas valve located on or near gas tank.
4. Check all joints of gas supply piping system. Apply a mixture of liquid soap and water to gas joints. Bubbles forming indicate a leak.
5. Correct all leaks immediately.
6. Reconnect heater and equipment shutoff valve to gas supply. Check reconnected fittings for leaks.

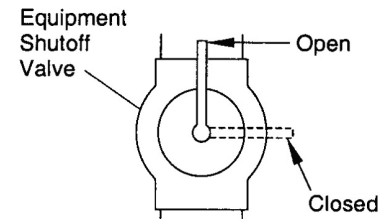

Figure 17- Equipment Shutoff Valve

Test Pressures Equal To or Less Than 1/2 PSIG

1. Close equipment shutoff valve (see Figure 17).
2. Pressurize supply piping system by either using compressed air or opening main gas valve located on or near gas supply tank.
3. Check all joints from gas tank to equipment shutoff valve (see Figure 18). Apply mixture of liquid soap and water to gas joints. Bubbles forming show a leak.
4. Correct all leaks immediately.

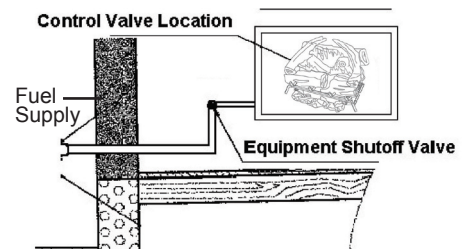

Figure 18 Checking Gas Joints

Pressure Testing Heater Gas Connections

1. Open equipment shutoff valve (see Figure 17).
2. Open main gas valve located on or near gas tank.
3. Make sure control knob of heater is in the OFF position.
4. Check all joints from equipment shutoff valve to control valve (see Figure 18). Apply mixture of liquid soap and water to gas joints. Bubbles forming show a leak.
5. Correct all leaks immediately.
6. Light heater (see *Operation*, pages 23 through 28). Check the rest of the internal joints for leaks.
7. Turn off heater (see "To Turn Off Gas to Appliance," page 24).

INSTALLING LOGS

18 IN. VENT-FREE GAS LOGS

⚠ WARNING: Failure to position the parts in accordance with these diagrams or failure to use only parts specifically approved with this heater may result in property damage or personal injury.

⚠ CAUTION: After installation and periodically thereafter, check to ensure that no yellow flame comes in contact with any log. With the heater set to High, check to see if yellow flames contact any log. If so, reposition logs according to the log installation instructions in this manual. Yellow flames contacting logs will create soot.

It is very important to install the logs exactly as instructed. Do not modify logs. Use only logs supplied with heater.

Each log is marked with a number. This number will help you to identify the logs when installing.

After installing logs, add decorative cinders around the grate base, do not place any decorative cinders on logs or burner.

Provided Logs: 7

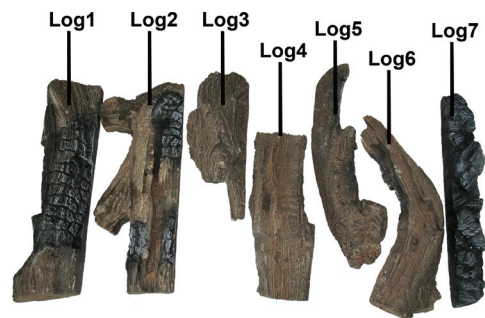

1. Insert log #1 into slots in rear log bracket on grate base, and tighten nuts.



Figure 19 - Installing Log #1

2. Insert log #2 into slots in middle grate bracket and tighten nuts.



Figure 20 - Installing Log #2

3. Insert log #3 into slots in front log bracket on grate base and tighten nuts.



Figure 21 - Installing Log #3

4. Insert log #4 into slots in front log bracket on grate base and tighten nuts.



Figure 22 - Installing Log #4

5. Insert the recessed hole on the bottom of log #5 onto pin on log #1, with the other end placed on log #4.



Figure 23 - Installing Log #5

6. Insert the recessed hole on the bottom of log #6 onto pin on log #1, with the other end placed on log #3.

Position #7 log on fireplace bottom in front of controls.

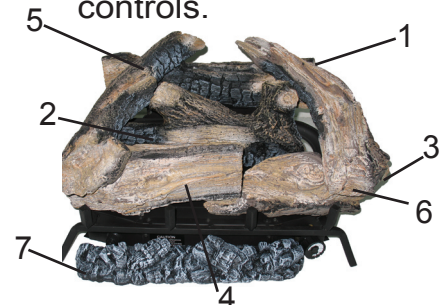

Figure 24 - Installing Log #6, and Log #7

INSTALLING LOGS

24 IN. VENT-FREE GAS LOGS

⚠ WARNING: Failure to position the parts in accordance with these diagrams or failure to use only parts specifically approved with this heater may result in property damage or personal injury.

⚠ CAUTION: After installation and periodically thereafter, check to ensure that no yellow flames contact any log. If so, reposition logs according to the log installation instructions in this manual. Yellow flames contacting logs will create soot.

It is very important to install the logs exactly as instructed. Do not modify logs. Use only logs supplied with heater.

Each log is marked with a number. This number will help you to identify the logs when installing.

After installing logs, add decorative cinders around the grate base, do not place any decorative cinders on logs or burner.

Provided Logs: 5



1. Insert log #1 into slots in rear log bracket on grate base, and tighten nuts.



Figure 25 - Installing Log #1

2. Insert log #2 into slots in middle grate bracket and tighten nuts.



Figure 26 - Installing Log #2

3. Insert log #3 into slots in front log bracket on grate base and tighten nuts.



Figure 27 - Installing Log #3

4. Insert log #4 into slots in front log bracket on grate base and tighten nuts.



Figure 28 - Installing Log #4

5. Insert the recessed hole on the bottom of log #5 onto the pin on log #1, with the other end placed on log #2.



Figure 29 - Installing Log #5

INSTALLING LOGS

24 IN. VENT-FREE GAS LOGS & 30 IN. VENT-FREE GAS LOGS

⚠ WARNING: Failure to position the parts in accordance with these diagrams or failure to use only parts specifically approved with this heater may result in property damage or personal injury.

⚠ CAUTION: After installation and periodically thereafter, check to ensure that no yellow yellow flames contact any log. If so, reposition logs according to the log installation instructions in this manual. Yellow flames contacting logs will create soot.

It is very important to install the logs exactly as instructed. Do not modify logs. Use only logs supplied with heater.

Each log is marked with a number. This number will help you to identify the logs when installing.

After installing logs, add decorative cinders around the grate base, do not place any decorative cinders on logs or burner.

Provided Logs: 7

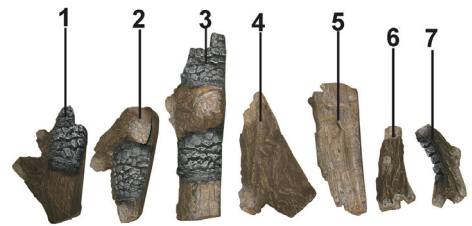

1. Insert log #3 into slots in middle grate, and tighten nuts.



Figure 30 - Installing Log #3

2. Insert log #2 into slots in rear log bracket on grate base, and tighten nuts.



Figure 31 - Installing Log #2

3. Insert log #1 into slots in rear log bracket on grate base, and tighten nuts.



Figure 32 - Installing Log #1

4. Insert log #4, log #5 into slots in front log bracket on grate base and tighten nuts.

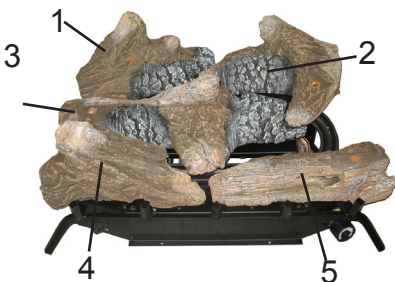

Figure 33 - Installing Log #4 and loge #5

5. Insert the recessed hole on the bottom of log #6 onto pin on log #1, with the other end placed on log #3.

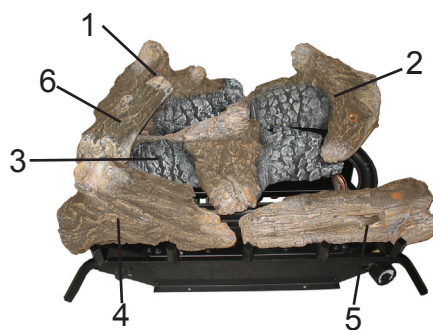

Figure 34 - Installing Log #6

6. Insert the recessed hole on the bottom of log #7 onto pin on log #2, with the other end placed on log #5.

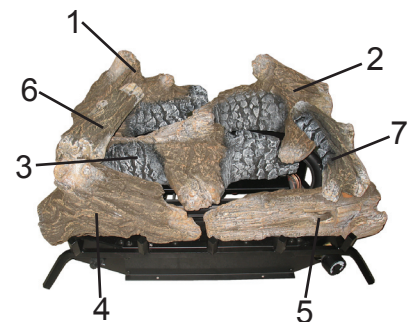

Figure 35 - Installing Log #7

INSTALLING REMOTE RECEIVER MODELS SSD24TR AND SSD30TR

The remote receiver operates on four 1.5V AA-size batteries. Use ALKALINE batteries for longer battery life and maximum microprocessor performance.

IMPORTANT: New or fully charged batteries are essential for proper operation of the remote receiver as the solenoid power consumption is higher than standard remote control systems.

1. Remove battery cover along the direction shown on the battery box, and install four 1.5V AA-size batteries into the box. (See Figure 36)
2. Rotate the log set and connect two wires (black and red) with two wires from AF-1100 valve. (See Figure 37)
3. With receiver wired to the valve, place receiver to the side of the log set. (See Figure 38)

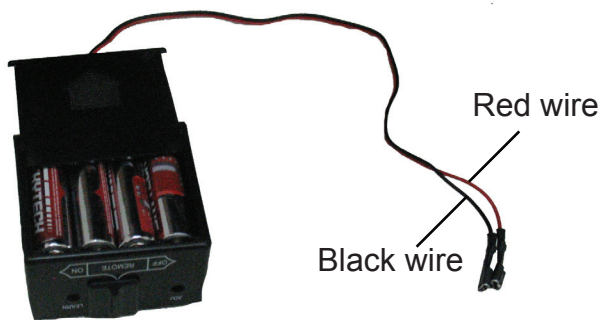

Figure 36

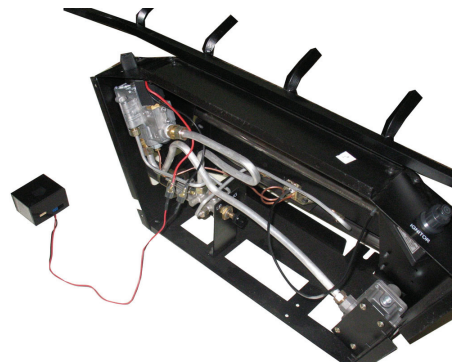

Figure 37



Figure 38

OPERATION

Avoid any drafts that alter burner flame patterns. Do not allow fans to blow directly into the fireplace. Do not place a blower inside the burn area of the firebox. Ceiling fans may create drafts that alter flame patterns. Sooting and improper burning will result.

During manufacturing, fabricating and shipping, various components of this appliance are treated with certain oils, films or bonding agents. These chemicals are not harmful but may produce annoying smoke and smells as they are burned off during the initial operation of the appliance, possibly causing headaches or eye or lung irritation. This is a normal and temporary occurrence.

The initial break-in operation should last two to three hours with the burner at the highest setting. Provide maximum ventilation by opening windows or doors to allow odors to dissipate. Any odors remaining after this initial break-in will be slight and will disappear with continued use.

This appliance must not be used with glass doors in the closed position. This can lead to pilot outages and severe sooting outside the fireplace.

Always operate heater with glass doors fully open.

FOR YOUR SAFETY READ BEFORE LIGHTING

⚠ WARNING: If you do not follow these instructions exactly, a fire or explosion may result causing property damage, personal injury or loss of life.

- A. When lighting the pilot, follow these instructions exactly.
- B. BEFORE LIGHTING smell all around the appliance area for gas. Be sure to smell next to the floor because some gas is heavier than air and will settle on the floor.

WHAT TO DO IF YOU SMELL GAS

- Do not try to light any appliance.
 - Do not touch any electrical switch; do not use any phone in your building.
 - Immediately call your gas supplier from a neighbor's phone. Follow the gas supplier's instructions.
 - If you cannot reach your gas supplier, call the fire department.
- C. Use only your hand to push control. Never use tools. If the appliance does not operate, don't try to repair it; call a qualified service technician or gas supplier. Forced or attempted repair may result in a fire or explosion.
 - D. Do not use this appliance if any part has been under water. Immediately call a qualified service technician to inspect the appliance and to replace any part of the control system and any gas control which has been under water.

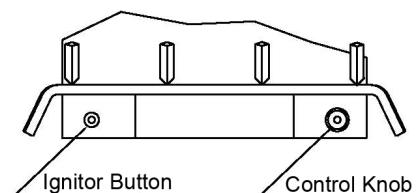



Figure 39 - Control Knob and Ignitor Button Location

LIGHTING INSTRUCTIONS

18 IN. VENT-FREE GAS LOGS & 24 IN. VENT-FREE GAS LOGS

⚠ CAUTION: Do not try to adjust heating levels by using the equipment shutoff valve.

1. Unscrew ignitor cap and install a AAA type battery with the anode (+) pointing out. Replace cap.
2. STOP! Read the safety information on front and back of the warning plate.
3. Make sure manual shutoff valve is fully, open.
4. Push in gas control knob slightly and turn clockwise  to the OFF position.
5. Wait five (5) minutes to clear out any gas. Then smell for gas, including near the floor. If you smell gas, STOP! Follow "B" in the safety information label. If you do not smell gas, go to the next step.
6. Push in gas control knob slightly and turn counterclockwise  to "PILOT" and depress for five (5) seconds. **NOTE:** The first time the heater is operated after connecting the gas supply, the control knob should be depressed for about thirty(30) seconds. This will allow air to bleed from the gas system.
7. With control knob pushed in, press and hold ignitor button, located on the other side of front panel. This will light the pilot. If needed, keep ignitor button pressed until pilot lights.
8. Continue pushing the control knob in for a further 60 seconds to allow thermocouple to warm up. Release the control knob.
Note: If pilot goes out, repeat steps 3 through 7. This heater has a safety interlock system. Wait one (1) minute before lighting pilot again.
9. Turn control knob counterclockwise to desired heating level. The main burner should light. Set control knob to any heat level between 1 and 5.

TO TURN OFF GAS TO APPLIANCE

Shutting Off Heater

Turn control knob clockwise  to the OFF position.

Shutting Off Burner Only (pilot stays lit)

Turn control knob clockwise  to the PILOT position.

MATCH LIGHTING INSTRUCTIONS

1. Remove any items necessary for easy access to the pilot (for example: logs, screens, etc.).
2. Follow appropriate lighting instructions found above. Instead of pushing the **piezo button**, light a match and hold the flame to the end of the pilot and ignite the pilot.
3. After control knob has been released and pilot stays lit, reinstall any items that were removed for pilot access.
4. Call a qualified service technician for repair or replacement of the piezo ignitor.

THERMOSTATIC CONTROL OPERATION



18 IN. VENT-FREE GAS LOGS & 24 IN. VENT-FREE GAS LOGS

The thermostatic control used on this model differs from standard thermostats. Standard thermostats simply turn the burner on and off. The thermostat used on this heater senses the room temperature. At times the room may exceed the set temperature. If so, the burner will shut off. The burner will cycle back on when room temperature drops below the set temperature. The control knob can be set to any comfort level.

Note: The thermostat sensing bulb measures the temperature. The thermostatic control used on this model differs from standard thermostats. Standard thermostats simply turn the burner on and off. The thermostat used on this heater senses the room temperature. At times the room may exceed the set temperature. If so, the burner will shut off. The burner will cycle back on when room temperature drops below the set temperature. The control knob can be set to any comfort level between HIGH (5) and LOW (1).

LIGHTING INSTRUCTIONS MODELS

24 IN. VENT-FREE GAS LOGS & 30 IN. VENT-FREE GAS LOGS

1. STOP! Read the safety information on front and back of the warning plate.
2. Make sure manual shutoff valve is fully open, and install three 1.5 V batteries in the transmitter.
3. Push in control knob slightly and turn clockwise  to the OFF position. If the switch is on ON or OFF position, adjust it to REMOTE position.
4. Wait five (5) minutes to clear out any gas. Then smell gas around heater and near floor. If you smell gas, STOP! Follow "B" in the safety information on Warning plate. If you don't smell gas, go to the next step.
5. Push in the control knob slightly and turn counterclockwise  to "PILOT" and depress for five (5) seconds. NOTE: The first time the heater is operated after connecting the gas supply, the control knob should be depressed for about thirty (30) seconds. This will allow gas to bleed from the gas system.
6. With the control knob pressed in, push down and release the ignitor button. This will light the pilot. If needed, keep pressing ignitor button until pilot lights.
7. Keep the control knob depressed for ten (10) seconds after lighting pilot. If pilot goes out, repeat step 5,6 and 7.
8. Rotate counterclockwise  to ON position, and then press button to light burner.
Note: You may be operating this heater for the first time after hooking up to gas supply. If so, the lighting will be lasted for 30 seconds. This will allow air to bleed from the gas system.
Note: If you miss your transmitter, adjust switch to ON position to light burner from the gas system.

TO TURN OFF GAS TO APPLIANCE

Shutting off heater

1. Press the **OFF** button to let pilot stay.
2. Turn gas control knob clockwise  to OFF position to shut off burner.

MATCH LIGHTING INSTRUCTIONS

1. Remove any items necessary for easy access to the pilot (for example: logs, screens, etc.).
2. Follow appropriate lighting instructions found previously. Instead of pushing the **piezo button**, light a match and hold the flame to the end of the pilot and ignite the pilot.
3. After control knob has been released and pilot stays lit, reinstall any items that were removed for pilot access.
4. Call a qualified service technician for repair or replacement of the piezo ignitor.

REMOTE CONTROL OPERATION

This appliance must not be used with glass doors in the closed position. This can lead to pilot outages and severe sooting outside the fireplace.

The transmitter operates on a (2) 1.5V AAA batteries.



Figure 40 - Transmitter

KEY SETTINGS

- ON** - Operates unit to on position, Manually operated solenoid ON.
- OFF** - Operates unit to off position, Manually operated solenoid OFF.
- MODE** - Changes unit from manual mode to thermo mode.
- SET** - Sets temperature in thermo mode.

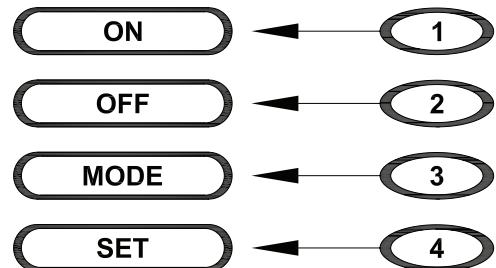

Figure 41

LCD Liquid Crystal Display

1. **DISPLAY** Indicates CURRENT room temperature.
2. **°F OR °C** Indicates degrees Fahrenheit or Celsius.
3. **FLAME** Indicates burner/valve in operation.
4. **ROOM** Indicates remote is in THERMO operation.
5. **TEMP** Appears during manual operation.
6. **SET** Appears during time the of setting the desired temperature in the thermo operation.

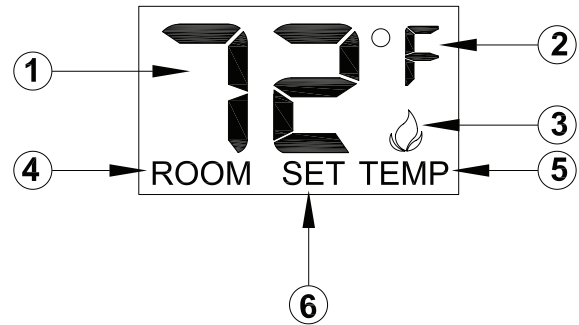

Figure 42

SETTING °F/°C SCALE

The factory setting for temperature is °F. To change this setting to °C ,
First

- Press the ON key and the OFF key on the transmitter at the same time this will change from °F to °C. Follow this same procedure to change from °C back to °F.

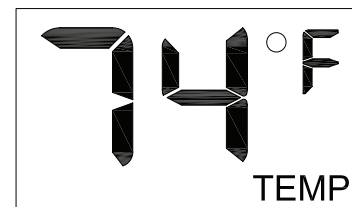

Figure 43

MANUAL FUNCTION

To operate the system in the manual "MODE" do the following.

ON OPERATION

Press the ON key and the appliance flame will come on. During this time the LCD screen will show ON (Figure 44). After 3 seconds the LCD screen will default to display room temperature and the word TEMP will show (Figure 45). (Flame icon will appear on LCD screen in manual on mode).



Figure 44

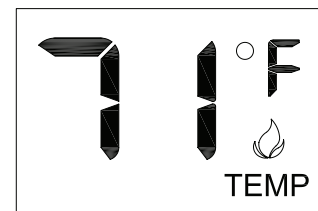

Figure 45

OFF OPERATION

Press the OFF key and the appliance flame will shut off. During this time the LCD screen will show OF (figure 46). After 3 seconds the LCD screen will default to display room temperature and the word TEMP will show (figure 47).

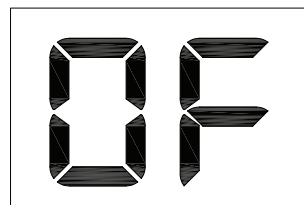

Figure 46

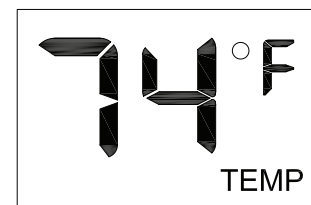

Figure 47

THERMOSTAT FUNCTION

SETTING DESIRED ROOM TEMPERATURE

This remote control system can control the thermostat when the transmitter is in the THERMO mode (The word **ROOM** must be displayed on the screen). To set the THERMO MODE and desired room temperature, Press the MODE

key until the LCD screen shows the word ROOM. Then the remote is in the thermostatic mode. Press and hold the SET key until the desired set temperature is reached. (By pressing and holding the set key the LCD screen set numbers will increase from 45° to 99° and then restart over at 45°) Next release the SET key. The LCD screen will display the set temperature for 3 seconds and the LCD screen will flash the set temperature for 3 seconds. Then the LCD screen will default to display the room temperature.

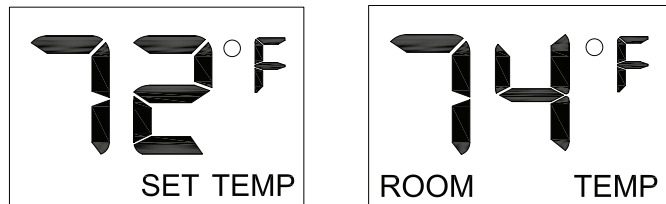

Figure 48

TO CHANGE THE SET TEMPERATURE

Press and hold the SET key until the desired set temperature is reached. (By pressing and holding the set key the LCD screen set numbers will increase from 45° to 99° then restart over at 45°). Next release the SET key. The LCD screen will display the set temperature for 3 seconds. Then

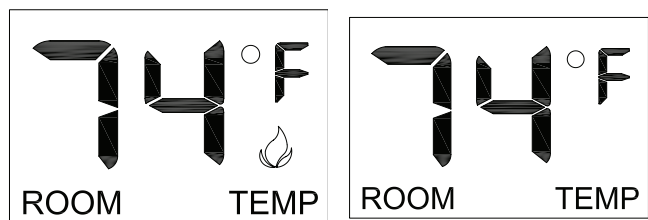

Figure 49

will flash the set temperature for 3 seconds. Then the LCD screen will default to display the room temperature. Press the MODE key to disengage the thermo mode. The word ROOM on the LCD screen will not show when the thermo is not in operation.

NOTE: The highest SET temperature is 99°F (32°C) and the lowest temperature is 45°F (6°C)

REMOTE CONTROL OPERATION NOTES:

The Thermo Feature on the transmitter operates the appliance whenever the ROOM TEMPERATURE varies a certain number of degrees from the SET TEMPERATURE. This variation is called the "SWING" or TEMPERATURE DIFFERENTIAL. The normal operating cycle of an appliance may be 2-4 times per hour depending on how well the room or home is insulated from the cold or drafts. The factory setting for the "swing number" is 2. This represents a temperature variation of +/-2°F (1°C) between SET temperature and ROOM temperature, which determines when the fireplace will be activated.

The transmitter has ON and OFF manual functions that are activated by pressing either button on the face of the transmitter. When a button on the transmitter is pressed the word ON or OF will appear on the LCD screen to show while the signal is being sent. Upon initial use, there may be a delay of three seconds before the remote receiver will respond to the transmitter. This is part of the system's design.

NOTE: This equipment has been tested and found to comply with the limits for Class B digital device, pursuant to part 15 of the FCC Rules. These limits are designed to provide reasonable protection against harmful interference in a residential installation. This equipment generates, uses and can radiate radio frequency energy and, if not installed and used in accordance with the instructions, may cause harmful interference to radio or television reception, which can be determined by turning the equipment off and on, the user is encouraged to try to correct the interference by one or more of the following measures:

- Reorient or relocate the receiving antenna.
- Increase the separation between the equipment and the receiver.
- Connect the equipment into an outlet on a circuit different from that to which the receiver is connected.
- Consult the dealer or an experienced radio/TV technician for help.

MATCHING SECURITY CODES

Program the remote receiver to LEARN a new security code by pushing in the LEARN button the top of the remote receiver and then pressing any button on the transmitter.

INSPECTING BURNERS

Check pilot flame pattern and burner flame patterns often.

PILOT FLAME PATTERN

Figure 50 shows a correct pilot flame pattern. Figure 51 shows an incorrect pilot flame pattern. The incorrect pilot flame is not touching the thermocouple. This will cause the thermocouple to cool. When the thermocouple cools, the heater will shut down.

If pilot flame pattern is incorrect, as shown in Figure 51:

- Turn heater off (see “To Turn Off Gas To Appliance”).
- See *Troubleshooting*, page 31.

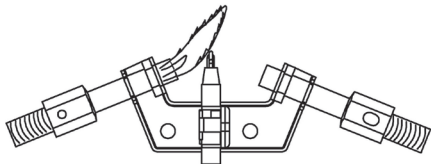

Figure 50 – Correct Pilot Flame Pattern

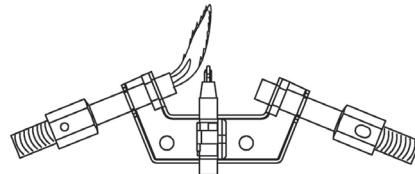

Figure 51– Incorrect Pilot Flame Pattern

BURNER FLAME PATTERN

Figure 52 shows a correct burner flame pattern. Figure 53 shows an incorrect burner flame pattern. If burner flame is incorrect, as shown in Figure 53:

- Turn heater off.
- See *Troubleshooting*, page 31.

Approx. 3 to 6 in. above top of logs



Figure 52– Correct Flame Pattern with Control Knob Set to High Flame

More than 8 in. above top of logs



Figure 53– Incorrect Flame Pattern with Control Knob Set to High Flame

CARE AND MAINTENANCE

⚠ WARNING: Turn off heater and let cool before cleaning.

⚠ CAUTION: You must keep control areas, burner, and circulating air passageways of heater clean. Inspect these areas of heater before each use. Have heater inspected yearly by a qualified service technician. Heater may need more frequent cleaning due to excessive lint from carpeting, bedding material, pet hair, etc.

The primary air inlet holes allow the proper amount of air to mix with the gas. This provides a clean burning flame. Keep these holes clear of dust, dirt and lint. Clean these air inlet holes prior to each heating season. Blocked air holes will create soot. We recommend that you clean the unit every 500 hours of operation or every three months.

CLEANING BURNER PILOT AIR INLET HOLE

We also recommend that you keep the burner tube and pilot assembly clean and free of dust and dirt. To clean these parts we recommend using compressed air no greater than 30 PSI. Your local computer store, hardware store, or home center may carry compressed air in a can, or you can use a vacuum cleaner in the blow position. If using compressed air in a can, please follow the directions on the can, or you could damage the pilot assembly.

1. Shut off the unit, including the pilot. Allow the unit to cool for at least thirty minutes.
2. Inspect burner, pilot, and primary air inlet holes on injector holder for dust and dirt (see Figure 54).
3. Blow air through the ports/slots and holes in the burner.
4. Check the injector holder located at the end of the burner tube again. Remove any large particles of dust, dirt, lint, or pet hairs with a soft cloth or vacuum cleaner nozzle.
5. Blow air into the primary air holes on the injector holder.
6. In case any large clumps of dust have now been pushed into the burner repeat steps 3 and 4.

Also clean the pilot assembly. A yellow tip on the pilot flame indicates dust and dirt in the pilot assembly. There is a small pilot air inlet hole about two inches from where the pilot flame comes out of the pilot assembly (see Figure 55). With the unit off, lightly blow air through the air inlet hole. You may blow through a drinking straw if compressed air is not available.

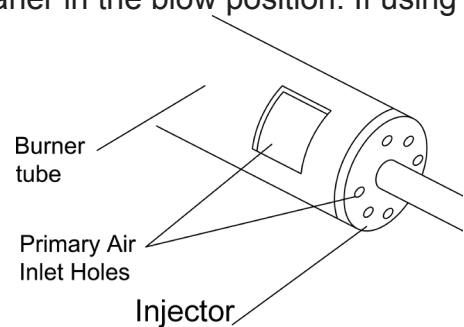

Figure 54– Injector Holder On Outlet Burner Tube

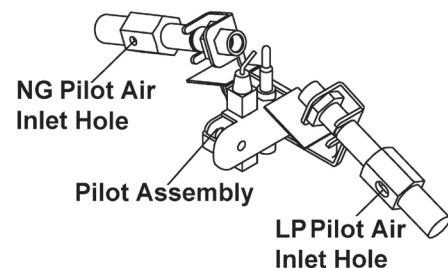

Figure 55– Pilot Inlet Air Hole

LOGS

- If you remove logs for cleaning, refer to "Installing Logs" to properly replace logs.
- Replace log(s) if broken or chipped (dime-size or larger).

MAIN BURNER

Periodically inspect all burner flame holes with the heater running. All slot burner flame holes should be open with yellow flame present.

All round burner flame holes should be open with a small blue flame present. Some burner flame holes may become blocked by debris or rust, with no flame present. If so, turn off heater and let cool. Either remove the blockage or replace the burner. Blocked burner flame holes will create soot.

TROUBLESHOOTING



WARNING: If you smell gas

- Shut off gas supply.
- Do not try to light any appliance.
- Do not touch any electrical switch; do not use any phone in your building.
- Immediately call your gas supplier from a neighbor's phone. Follow the gas supplier's instructions.
- If you cannot reach your gas supplier, call the fire department.



IMPORTANT: Operating heater where impurities in air exist may create odors. Cleaning supplies, paint, paint remover, cigarette smoke, cements and glues, new carpet or textiles, etc., create fumes. These fumes may mix with combustion air and create odors.



WARNING: Only a qualified service technician should service and repair heater.



CAUTION: Never use a wire, needle, or similar object to clean ODS/pilot. This can damage ODS/ pilot unit.

NOTE: All troubleshooting items are listed in order of operation.

TROUBLESHOOTING

PROBLEM	POSSIBLE CAUSE	REMEDY
When ignitor button is pressed in, there is no spark at ODS/pilot.	<ol style="list-style-type: none"> 1. Ignitor electrode positioned wrong. 2. Ignitor electrode broken. 3. Ignitor electrode not connected to ignitor cable. 4. Ignitor cable pinched or wet. 5. Broken ignitor cable. 6. Bad piezo ignitor. 7. Battery too low. 	<ol style="list-style-type: none"> 1. Replace electrode. 2. Replace electrode. 3. Reconnect ignitor cable. 4. Free ignitor cable if pinched by any metal or tubing. Keep ignitor cable dry. 5. Replace ignitor cable. 6. Replace ignitor. 7. Replace battery.
ODS/pilot lights but flame goes out when control knob is released.	<ol style="list-style-type: none"> 1. Gas supply turned off or equipment shutoff valve closed. 2. Control knob not fully pressed in while pressing ignitor button. 3. Air in gas lines when installed. 4. ODS/pilot is clogged. 5. Control knob not in pilot position. 6. Gas regulator setting is not correct. 	<ol style="list-style-type: none"> 1. Turn on gas supply or open equipment shutoff valve. 2. Fully press in control knob while pressing ignitor button. 3. Continue holding down control knob. Repeat igniting operation until air is removed. 4. Clean ODS/pilot (see <i>Care and Maintenance</i> page 30). or replace ODS/pilot assembly. 5. Turn control knob to pilot position. 6. Replace gas regulator.
When ignitor button is pressed in, there is a spark at ODS/pilot but no ignition.	<ol style="list-style-type: none"> 1. Control knob not fully pressed in. 2. Control knob not pressed in long enough. 3. Equipment shutoff valve not fully open. 4. Thermocouple connection loose at control valve. 5. Pilot flame not touching thermocouple, which allows thermocouple. This problem could be caused by one or both of the following: <ol style="list-style-type: none"> a) Low gas pressure. b) Dirty or partially clogged ODS/pilot 6. Control valve damaged. 	<ol style="list-style-type: none"> 1. Pressed in control knob fully. 2. After ODS/pilot lights, keep control knob pressed in 30 seconds. 3. Fully open equipment shutoff valve. 4. Hand tighten until snug, and then tighten 1/4 turn more. 5. <ol style="list-style-type: none"> a) Contact local natural or propane/LP gas company. b) Clean ODS/pilot (see <i>Care and Maintenance</i> page 30), or replace ODS/pilot assembly. 6. Replace control valve.

PROBLEM	POSSIBLE CAUSE	REMEDY
Burner(s) does not light after ODS/pilot is lit.	<ol style="list-style-type: none"> 1. Burner orifice is clogged. 2. Burner orifice diameter is too small. 3. Inlet gas pressure is too low. 	<ol style="list-style-type: none"> 1. Clean burner orifice (see <i>Care and Maintenance</i> page 30) or replace burner orifice. 2. Replace burner orifice. 3. Contact local natural or propane/LP gas company.
Delayed ignition of burner(s).	<ol style="list-style-type: none"> 1. Manifold pressure is too low. 2. Burner orifice is clogged. 	<ol style="list-style-type: none"> 1. Contact local natural or propane/LP gas company. 2. Clean burner (see <i>Care and Maintenance</i> page 30) or replace burner orifice.
Burner backfiring during combustion.	<ol style="list-style-type: none"> 1. Burner orifice is clogged or damaged. 2. Burner damaged. 3. Gas regulator defective. 	<ol style="list-style-type: none"> 1. Clean burner orifice (see <i>Care and Maintenance</i> page 30) or replace Burner orifice. 2. Replace burner. 3. Replace gas regulator.
Slight smoke or odor during initial operation.	<ol style="list-style-type: none"> 1. Residues from manufactory. 2. Not enough combustion/ventilation air. 	<ol style="list-style-type: none"> 1. Problem will stop after a few hours. 2. Refer to air for combustion and ventilation requirements.
White powder residue forming within burner box or on adjacent walls or furniture.	<ol style="list-style-type: none"> 1. When heated, vapors from furniture polish, wax, carpet cleaners, etc., turn into white powder residue. 	<ol style="list-style-type: none"> 1. Turn heater off when using furniture polish, wax, carpet cleaner or similar products.
Heater produces a clicking/ticking noise just after burner is lit or shut off.	<ol style="list-style-type: none"> 1. Metal expanding while heating or contracting while cooling. 	<ol style="list-style-type: none"> 1. This is common with most heaters. if noise is excessive, contact qualified service technician.
Heater produces unwanted odors.	<ol style="list-style-type: none"> 1. Heater burning vapors from paint, hair spray, glues, cleaners, chemicals, new carpet, etc. (See IMPORTANT, page 31). 2. Gas leak. See “Warning ” statement, page 31. 	<ol style="list-style-type: none"> 1. Open window and ventilate room. Stop using. 2. Locate and correct all leaks (see “Checking Gas Connections ” page 18).

PROBLEM	POSSIBLE CAUSE	REMEDY
Heater shuts off in use (ODS operates).	<ol style="list-style-type: none"> 1. Not enough fresh air is available. 2. Low line pressure. 3. ODS/pilot is partially clogged. 	<ol style="list-style-type: none"> 1. Open window and/or door for ventilation. 2. Contact local natural or propane/LP gas company. 3. Clean ODS/pilot (see <i>Care and Maintenance</i> page 30).
Gas odor even when control knob is in OFF position.	<ol style="list-style-type: none"> 1. Gas leak. See Warning statement, page 31. 2. Control valve defective. 	<ol style="list-style-type: none"> 1. Locate and correct all leaks(see "Checking Gas Connections" page 18. 2. Replace control valve.
Gas odor during combustion.	<ol style="list-style-type: none"> 1. Foreign matter between control valve and burner. 2. Gas leak. See Warning statement page 31. 	<ol style="list-style-type: none"> 1. Take apart gas tubing and remove foreign matter. 2. Locate and correct all leaks (see "<i>Checking Gas Connections</i>" page 18.)

REPLACEMENT PARTS

NOTE: Use only original replacement parts. This will protect your warranty coverage for parts replaced under warranty.

PARTS UNDER WARRANTY

Contact authorized dealers of this product. If they can't supply original replacement parts, call Customer Service toll free at (1-866-573-0674) for referral information.

When calling Customer Service or your dealer, have ready:

- Your name
- Your address
- Model and serial number of your heater
- How heater was malfunctioning
- Type of gas used (Propane/LP or Natural gas/NG)
- Purchase date
- Usually, we will ask you to return the defective part to the factory

PARTS NOT UNDER WARRANTY

Contact authorized dealers of this product. If they can't supply original replacement part(s) call Customer Service toll free at (1-866-573-0674) for referral information.

When calling Customer Service have ready:

- Model number of your heater
- The replacement part number

18 IN. VENT-FREE GAS LOGS

This list contains replaceable parts for your heater. When ordering replacement parts, follow the instructions listed under Replacement Parts on page 34 of this manual.

KEY NO	PART NUMBERS	DESCRIPTION	QTY
1	WYL001-01DT	Back Side Panel	1
2	WYL002-01DT	Left Side Panel	1
3	WYL003-01DT	Right Side Panel	1
4	WYL004-01	Front Side panel	1
5	WYL005-01	Front Log Bracket	1
6	WYL006-01D	Middle Log Bracket	1
7	AL092-01	Ignitor	1
8	WYB002-01	Log Fence Assembly	1
9	WYL008-01	T-Stat Valve Bracket	1
10	WYL007-01D	Regulator Bracket	1
11	SIT545	SIT545 T-Stat Valve Bracket	1
12-A	RV83FI (L) (S)	Dual Fuel Regulator	1
12-B	PF120820	Regulator Plug	1
13	WYB204-01D	ODS Inlet Tube Assembly	1
14	WYB202-01D	Inlet Tube Assembly	1
15	WYB203-01D	Outlet Tube Assembly	1
16	WYB204-01DN	ODS Outlet Tube Assembly (NG)	1
17	WYB204-01DL	ODS Outlet Tube Assembly (LP)	1
18	ML029-01	Main Valve Nut	1
19	MDL304B	Knob	1
20	NBY28D-160	Burner	1
21	NDD0308	Dual fuel ODS	1
22	WYL501-01	Log 1	1
23	WYL502-01	Log 2	1
24	WYL503-01	Log 3	1
25	WYL504-01	Log 4	1
26	WYL505-01	Log 5	1
27	WYL506-01	Log 6	1
28	WYL507-01	Log 7	1

18 IN. VENT-FREE GAS LOGS

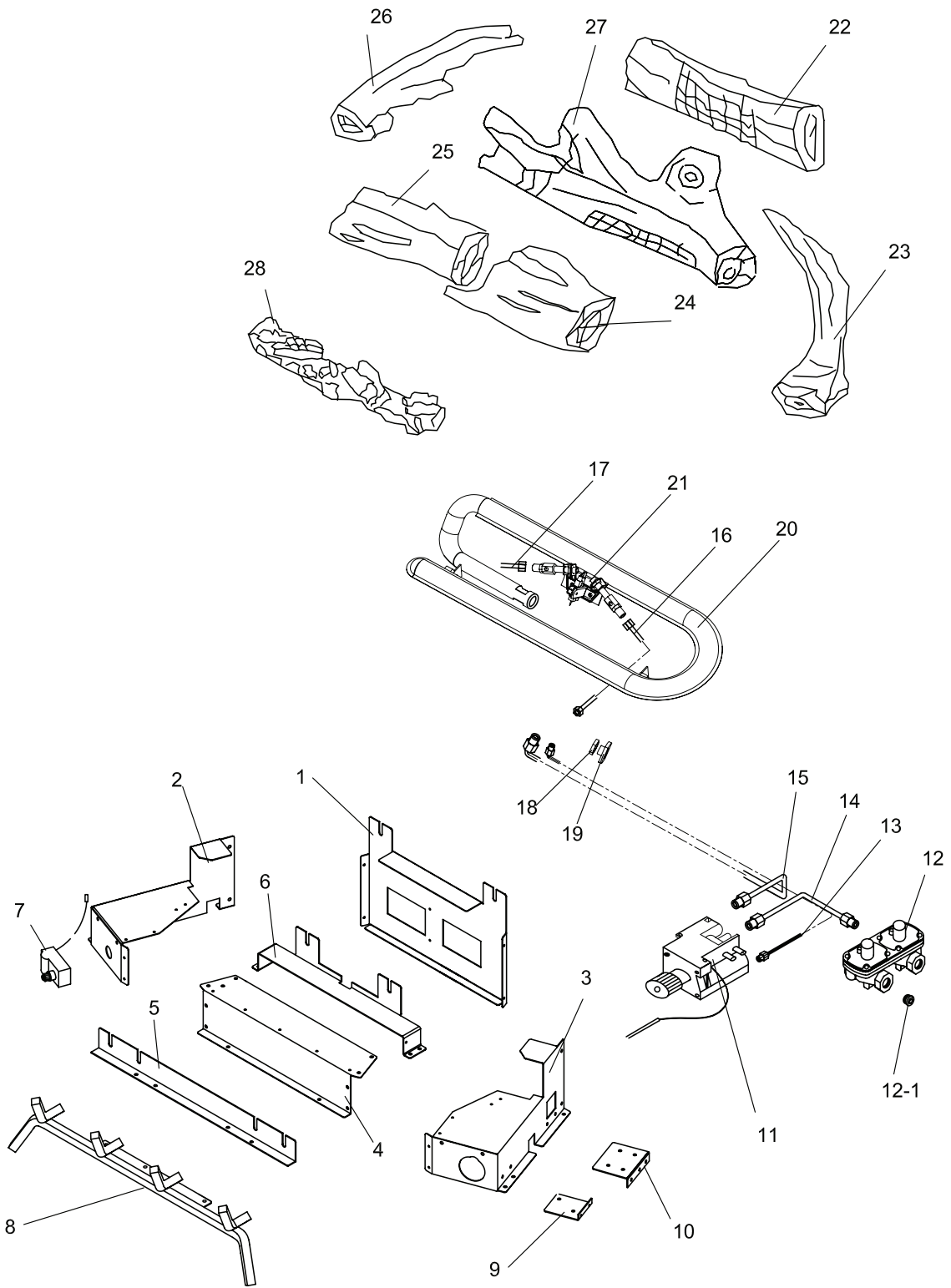

24 IN. VENT-FREE GAS LOGS

This list contains replaceable parts for your heater. When ordering replacement parts, follow the instructions listed under Replacement Parts on page 34 of this manual.

KEY NO	PART NUMBERS	DESCRIPTION	QTY
1	WYL001-02DT	Rear Chassis Panel	1
2	WYL002-01DT	Left Chassis Panel	1
3	WYL003-01DT	Right Chassis Panel	1
4	WYL004-02	Front Chassis Panel	1
5	WYL005-01F	Front Log Bracket	1
6	WYL006-02D	Mid Log Bracket	1
7	AL092-01	Piezo Ignitor	1
8	WYB002-02	Grate Assembly	1
9	WYL008-01	T-STAT Valve Bracket	1
10	WYL007-01D	Regulator Bracket	1
11	SIT545	SIT545 T-STAT Valve	1
12-A	RV83FI(L)(S)	DF Regulator	1
12-B	PF120820	Regulator Plug	1
13	WYB204-02D	ODS/Pilot Gas Tube Assembly	1
14	WYB202-02D	Main Inlet Tube ASSEMBLY	1
15	WYB203-02D	Main Outlet Tube Assembly	1
16	WYB204-02DN	ODS Outlet Tube	1
17	WYB204-02DL	ODS Outlet Tube	1
18	ML029-01	Gas Selector Retainer Nut	1
19	MDL304B	Gas Selector Knob	1
20	NBY39A-D160	Burner	1
21	NDD0308	DF ODS	1
22	WYL524-1	Log 1	1
23	WYL524-2	Log 2	1
24	WYL524-3	Log 3	1
25	WYL524-4	Log 4	1
26	WYL524-5	Log 5	1

24 IN. VENT-FREE GAS LOGS

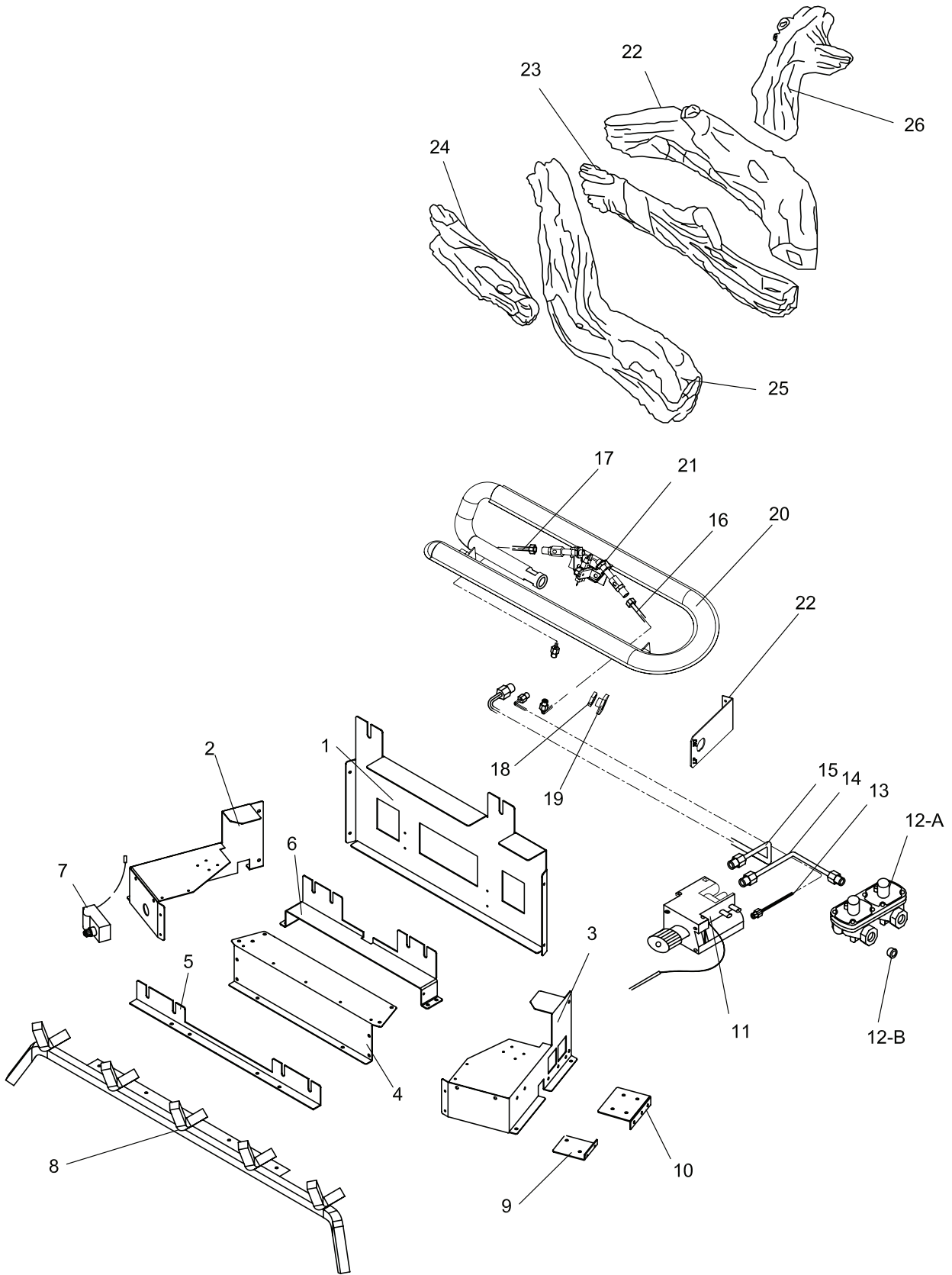

24 IN. VENT-FREE GAS LOGS & 30 IN. VENT-FREE GAS LOGS

This list contains replaceable parts for your heater. When ordering replacement parts, follow the instructions listed under Replacement Parts on page 34 of this manual.

KEY NO	PART NUMBERS FOR		DESCRIPTION	QTY
	24 IN. VENT-FREE GAS LOGS	30 IN. VENT-FREE GAS LOGS		
1	WYL001-02DT	WYL001-02DT	Rear Chassis Panel	1
2	WYL002-01DF	WYL002-01DF	Left Chassis Panel	1
3	WYL003-01DF	WYL003-01DF	Right Chassis Panel	1
4	WYL004-02	WYL004-02	Front Chassis Panel	1
5	WYL005-01F	WYL005-01F	Front Log Bracket	1
6	WYL006-02D	WYL006-02D	Mid Log Bracket	1
7	AL092-01	AL092-01	Piezo Ignitor	1
8	WYB002-02	WYB002-03	Grate Assembly	1
9	WYL009-01	WYL009-01	AF Valve Bracket	1
10	WYL007-01D	WYL007-01D	Regulator Bracket	1
11	RG01-2M	RG01-2M	Control Case	1
12	CON1001TH	CON1001TH	Remote Control	1
13	AF-1110	AF-1110	Control Valve	1
14-A	RV83F1(L)(S)	RV83F1(L)(S)	DF Regulator	1
14-B	PF120820	PF120820	Regulator Plug	1
15	WYB202-02DF	WYB202-02DF	Main Inlet Tube ASSEMBLY	1
16	WYB203-02DF	WYB203-02DF	Main Outlet Tube Assembly	1
17	WYB204-02DF	WYB204-02DF	ODS/Pilot Gas Tube Assembly	1
18	WYB204-02DFN	WYB204-02DFN	ODS Outlet Tube	1
19	WYB204-02DFL	WYB204-02DFL	ODS Outlet Tube	1
20	ML029-01	ML029-01	Gas Selector Retainer Nut	1
21	MDL304B	MDL304B	Gas Selector Knob	1
22	NB39B-D160	NB39B-D160	Burner	1
23	NDD0308	NDD0308	DF ODS	1
24	WYL522-1	WYL532-1	Log 1	1
25	WYL522-2	WYL532-2	Log 2	1
26	WYL522-3	WYL532-3	Log 3	1
27	WYL522-4	WYL532-4	Log 4	1
28	WYL522-5	WYL532-5	Log 5	1
29	WYL522-6	WYL532-6	Log 6	1
30	WYL522-7	WYL532-7	Log 7	1

24 IN. VENT-FREE GAS LOGS & 30 IN. VENT-FREE GAS LOGS

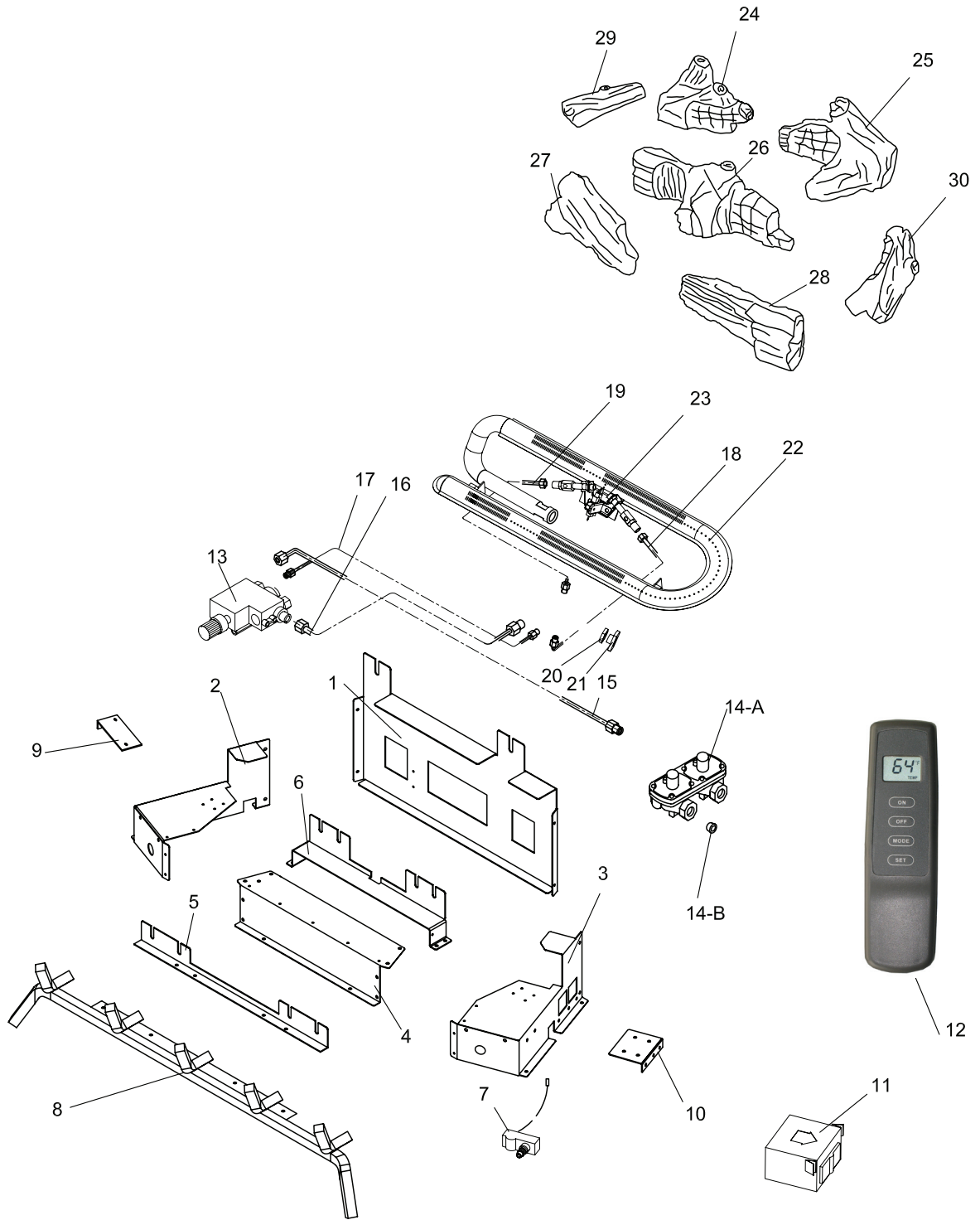

3-YEAR LIMITED WARRANTY

The manufacturer warrants this product to be free from defects in workmanship and material present at time of shipment from the factory for three (3) years from the date of purchase. This warranty applies only to the original purchaser. The manufacturer agrees to correct such defect at no charge or, at our option, replace the product with a comparable or superior model.

To obtain warranty service, call our customer service department at 1-866-573-0674 for return authorization and shipping instructions. You may be required to present a copy of your sales receipt as proof of purchase. All costs of removal and reinstallation are the expressed responsibility of the purchaser. Any damage to the product by accident, misuse or improper installation, or by affixing accessories not produced by the manufacturer, are the purchaser's responsibility. The manufacturer assumes no responsibility whatsoever for installation during the warranty period.

There is no further expressed warranty. The manufacturer disclaims any and all implied warranties. The manufacturer shall not be liable for incidental, consequential or special damages arising at or in connection with product use or performance except as may otherwise be accorded by law. This warranty gives you specific legal rights, and you also have other rights which vary from state to state. This warranty supersedes all prior warranties.

Distributed by:

L G Sourcing, Inc.

P.O. Box 1535

N. Wilkesboro, NC 28659 USA