

PIPE DECOR[®] PIPE BRIDGE TABLE 365KT2

We take pride in our customer service and your satisfaction is very important to us. If you have any questions or problems please contact us right away at help@jsupplies.com. Thank you for your business!

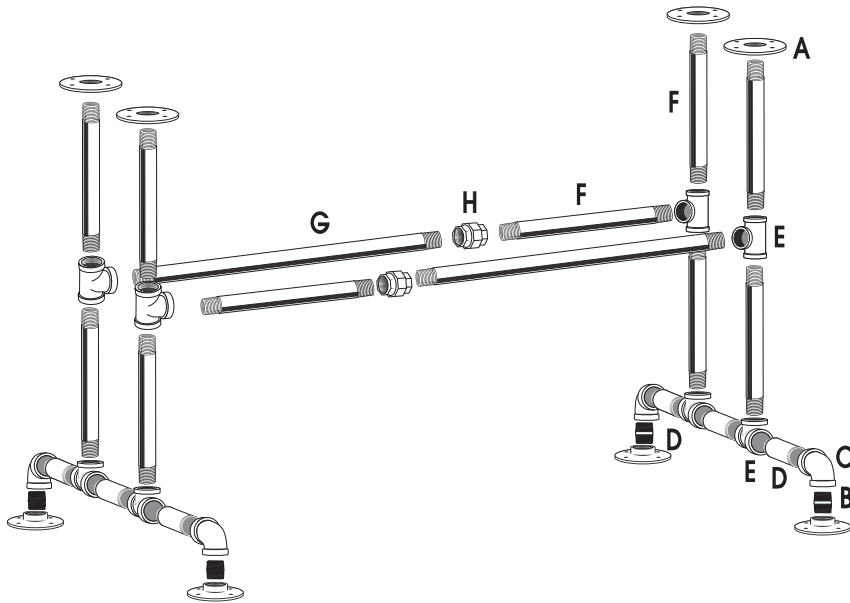

This kit is made of industrial grade authentic pipe. It is coated in oil post production to prevent rust. The kit should be cleaned and sealed to prevent rusting. See Clean and Seal sheet for more information on cleaning and sealing your pipe kit.

1. Assemble Each Leg with a 2 X FLANGE (A) 2 X CONNECTORS (B), 2 X ELBOW (C), 3 X 5 IN PIPE (D), and 2 X TEES (E) as shown in Box. Repeat with other leg
2. Connect 2 X 12 IN PIPE (F), 1 X TEE (E), and 1 X FLANGE to Each TEE on the legs.
3. Connect the sides with each other using 2 X 12 IN PIPE, 1 X UNIONS(H), and 1 X 18 IN PIPE (G). Screw in the 12 IN and 18 IN PIPE into the union as tight as you can. Screw in one side into a TEE as tight as you can. Loosen the union and screw in the the other side into the other TEE until tight. Repeat with other side.
4. Loosen or tighten flanges to level table, and screw into table top.

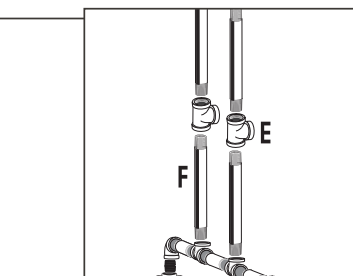
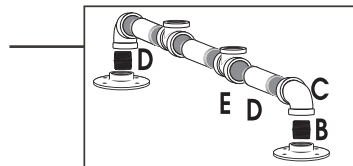

A - 8 X FLANGES(3/4 IN)

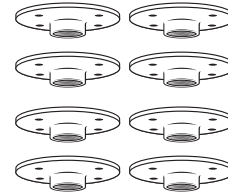

B - 4 X CONNECTORS(3/4 IN)



C - 4 X ELBOWS(3/4 IN)



D - 6 X 5" PIPE(3/4 IN)

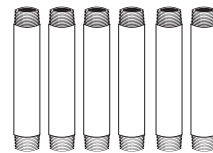

E - 8 X TEES(3/4 IN)

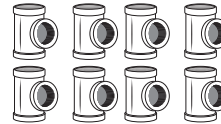

F - 10 X 12" PIPE(3/4 IN)

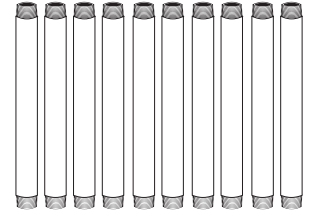

G - 2 X 18" PIPE(3/4 IN)



H - 2 X UNION(3/4 IN)



I - 16 X HARDWARE SCREWS

RECOMMENDED TOOLS

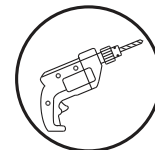

RECOMMENDED FOR ATTACHING LEGS TO TABLE TOP

LOOSEN UNION



USE BOLT TO TURN THE PIPE FOR CONNECTION 4

Connect parts in the following order



Flanges may scratch floor and pads are recommended.