

## ROLLING CLOTHING RACK - 2 TIER

NEED HELP OR ADVICE PUTTING THIS KIT TOGETHER? MISSING PIECES?  
EMAIL US AT [SUPPORT@PIPE-DECOR.COM](mailto:SUPPORT@PIPE-DECOR.COM) FOR ANY QUESTIONS

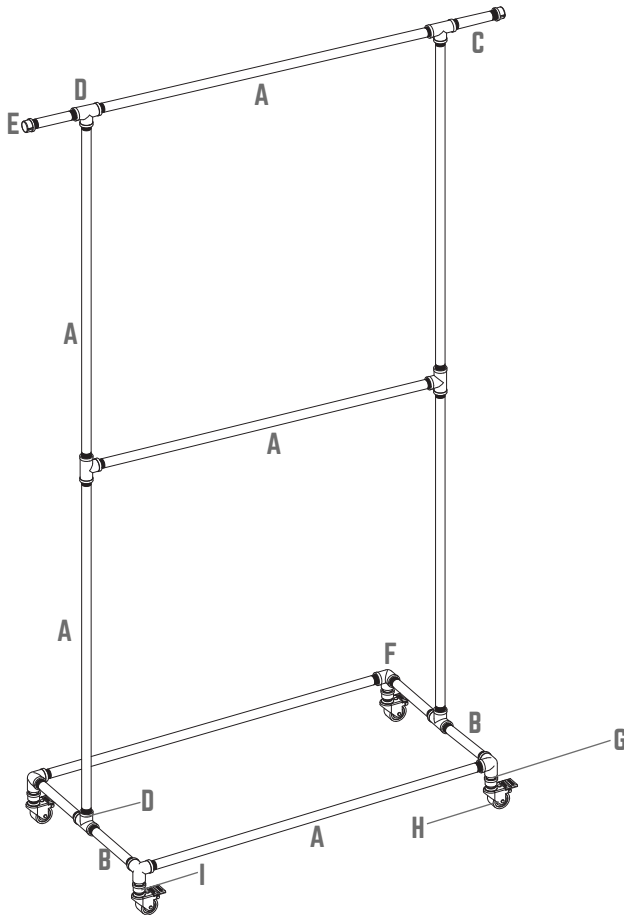

### RECOMMENDED TOOLS FOR INSTALLATION

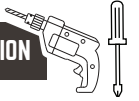

PART	DESCRIPTION	QTY
A	36" PIPE	8
B	8" NIPPLE	4
C	4" NIPPLE	2
D	1/2" TEE	6
E	1/2" CAP	2
F	1/2" SIDE OUTLET ELBOW	4
G	1-1/2" NIPPLE	4
H	CASTER WITH BRAKE	4
I	1/2" TAPPED CAP	4



### HOW TO PREVENT PIPE CORROSION

PIPE DECOR industrial-grade black pipes and fittings are coated with a rust-preventive oil during manufacturing. For best results, **SEAL THE PIPES TO AVOID ANY RUSTING** after cleaning the kit.

#### CLEAN AND SEAL INSTRUCTIONS:

- CLEAN:** Recommended supplies: regular degreasing dish soap, washcloths, gloves (optional)
1. Wash your pipes and fittings with warm water and dish soap until the oil is completely removed.
  2. Wipe the pipes with a dry washcloth and wait until the pipes are completely dry.

**IMPORTANT: THE PIPES MUST BE COMPLETELY DRY BEFORE YOU START THE SEALING PROCESS.**

**SEAL:** **IF USING POLYURETHANE SPRAY:** Spray each dry pipe and fitting with a polyurethane matte or satin finishing spray and let it dry before assembling the kit.

**IF USING FINISHING WAX:** Coat each dry pipe with a finishing wax. Wait for 20 minutes, then polish the pipe with a dry washcloth by wiping them down. Faster wiping will result in a shinier finish.

## ROLLING CLOTHING RACK - 2 TIER

**STEP 1** Start with the top pipe (36")

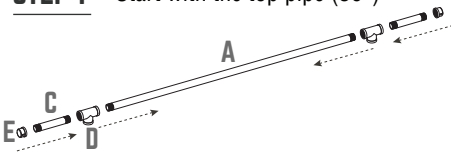

**STEP 2**

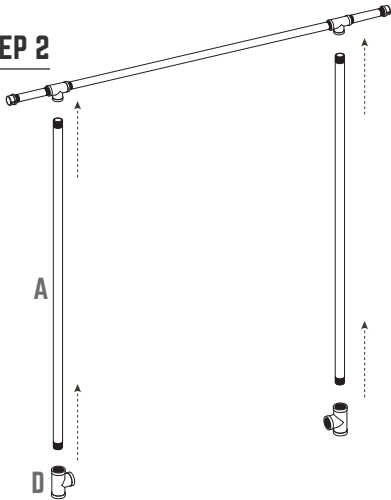

**STEP 5**

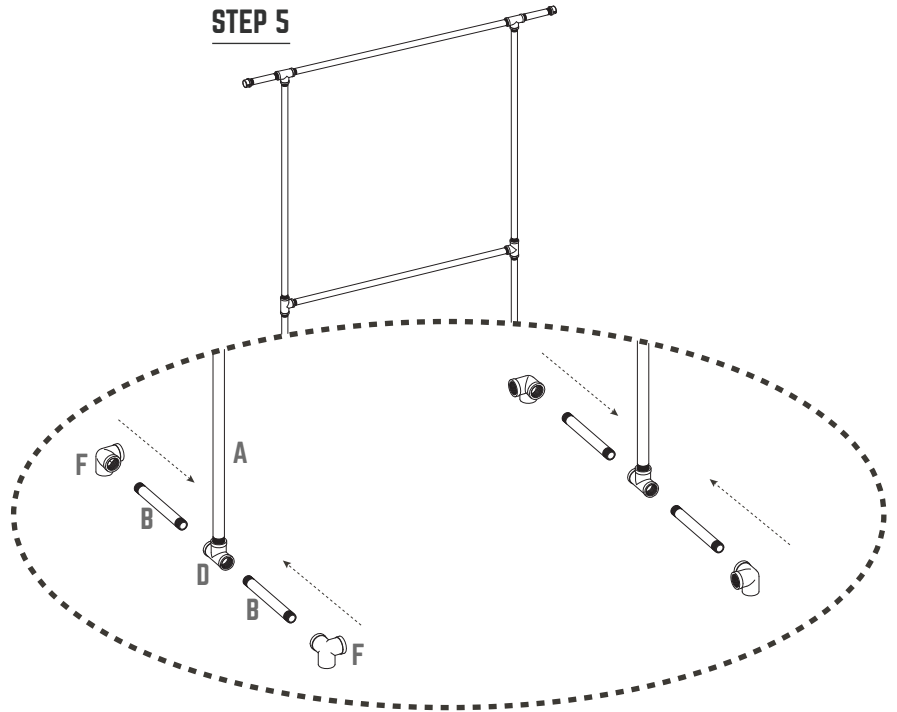

**STEP 3** **1** → Hand tighten A into D as hard as you can.

**2** → Then unscrew the A (in **1**) into the the opposite D (in **2**). It will be loose, but the connection is good.

**STEP 6**

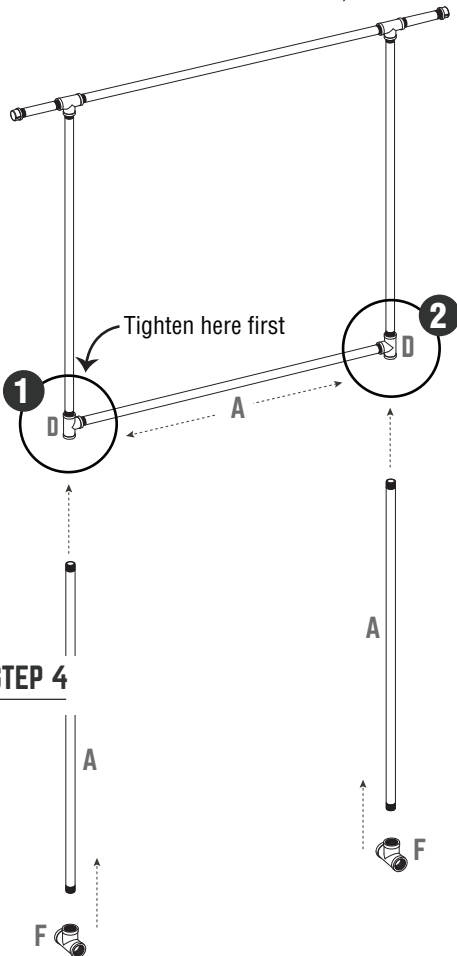

**STEP 4**

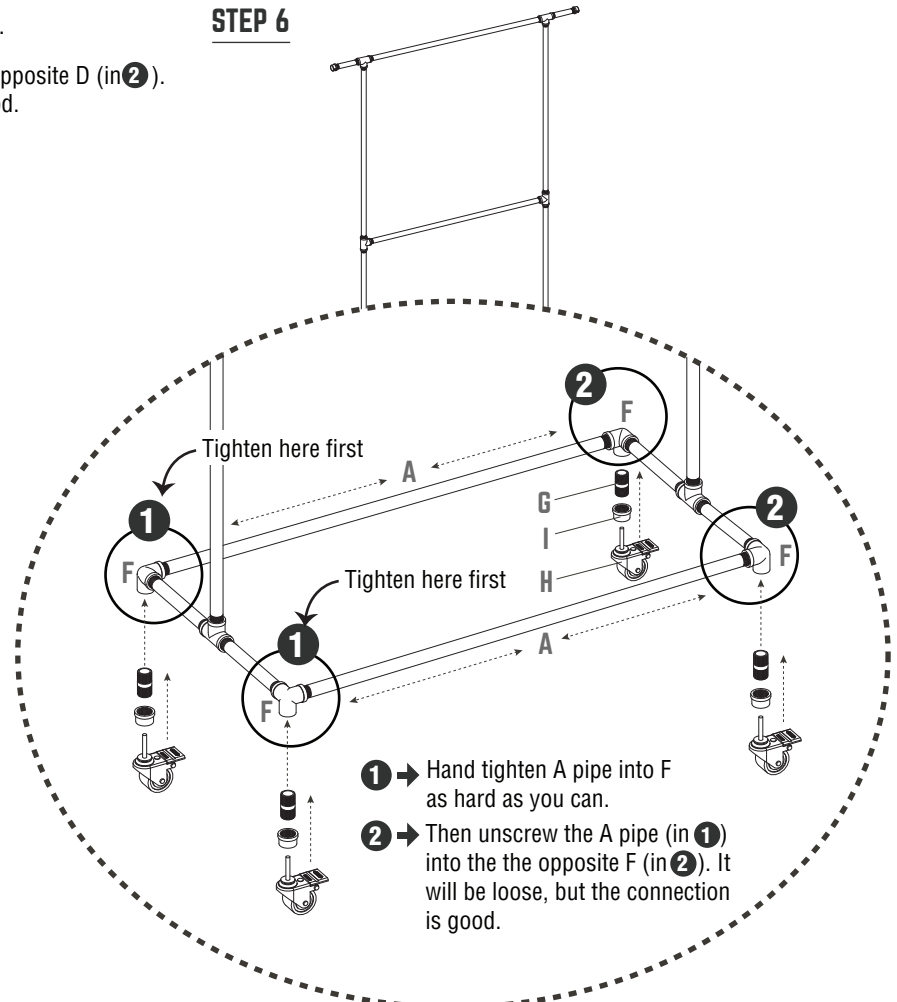

**1** → Hand tighten A pipe into F as hard as you can.

**2** → Then unscrew the A pipe (in **1**) into the the opposite F (in **2**). It will be loose, but the connection is good.