

## 4" DOUBLE FLANGE SHELF BRACKET (4 PACK)

NEED HELP OR ADVICE ON PUTTING THIS KIT TOGETHER? MISSING PIECES?  
EMAIL US AT [SUPPORT@PIPE-DECOR.COM](mailto:support@pipe-decor.com) FOR ANY QUESTIONS

### RECOMMENDED TOOLS FOR INSTALLATION

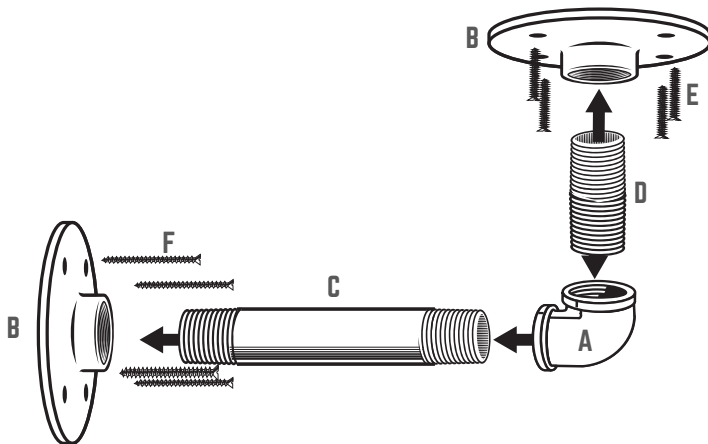
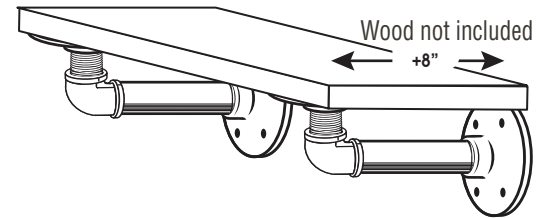

PART	DESCRIPTION	QTY
A	1/2" 90° ELBOW	2
B	1/2" FLANGE	3
C	4" NIPPLE	1
D	1" CONNECTOR	1
E	#10 X 3/4" SCREWS	16
F	#10 X 1-3/4" SCREWS	16
G	ANCHORS	16

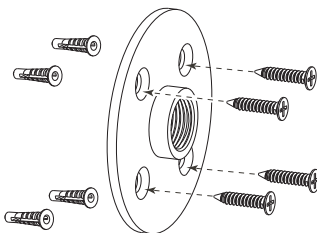

- Place flange against wall in desired location and mark holes with pencil
- Using stud finder, locate and mark wall stud if found
  - A) If a wall stud is present, attach flange to wall with included screws
  - b) If no wall stud is present:
    - Drill pilot holes in wall using 1/4" drill bit
    - Insert anchor fully into pilot hole using hammer and Phillips screwdriver as needed
    - Attach flange to wall using included screws



## HOW TO PREVENT PIPE CORROSION

PIPE DECOR industrial-grade black pipes and fittings are coated with a rust-preventive oil during manufacturing. For best results, **SEAL THE PIPES TO AVOID ANY RUSTING** after cleaning the kit.

### CLEAN AND SEAL INSTRUCTIONS:

- CLEAN:** Recommended supplies: regular degreasing dish soap, washcloths, gloves (optional)
1. Wash your pipes and fittings with warm water and dish soap until the oil is completely removed.
  2. Wipe the pipes with a dry washcloth and wait until the pipes are completely dry.

**IMPORTANT: THE PIPES MUST BE COMPLETELY DRY BEFORE YOU START THE SEALING PROCESS.**

- SEAL:** **IF USING POLYURETHANE SPRAY:** Spray each dry pipe and fitting with a polyurethane matte or satin finishing spray and let it dry before assembling the kit.

**IF USING FINISHING WAX:** Coat each dry pipe with a finishing wax. Wait for 20 minutes, then polish the pipe with a dry washcloth by wiping them down. Faster wiping will result in a shinier finish.