

# PIPE DECOR®

# 365 340HL / 365 340HL2PK

## 3/4" H-LEG OUTSIDE TABLE KIT

NEED HELP OR ADVICE PUTTING THIS KIT TOGETHER? MISSING PIECES?  
EMAIL US AT [SUPPORT@PIPE-DECOR.COM](mailto:SUPPORT@PIPE-DECOR.COM) FOR ANY QUESTIONS

### # 365 340HL (1 PACK)

PART	DESCRIPTION	QTY
A	3/4" FLANGE	4
B	3/4" TEE	2
C	8" PIPE	2
D	18" PIPE	2
E	16" PIPE SCREWS	1
F	SCREWS	8

### # 365 340HL2PK (2 PACK)

PART	DESCRIPTION	QTY
A	3/4" FLANGE	8
B	3/4" TEE	4
C	8" PIPE	4
D	18" PIPE	4
E	16" PIPE SCREWS	2
F	SCREWS	16

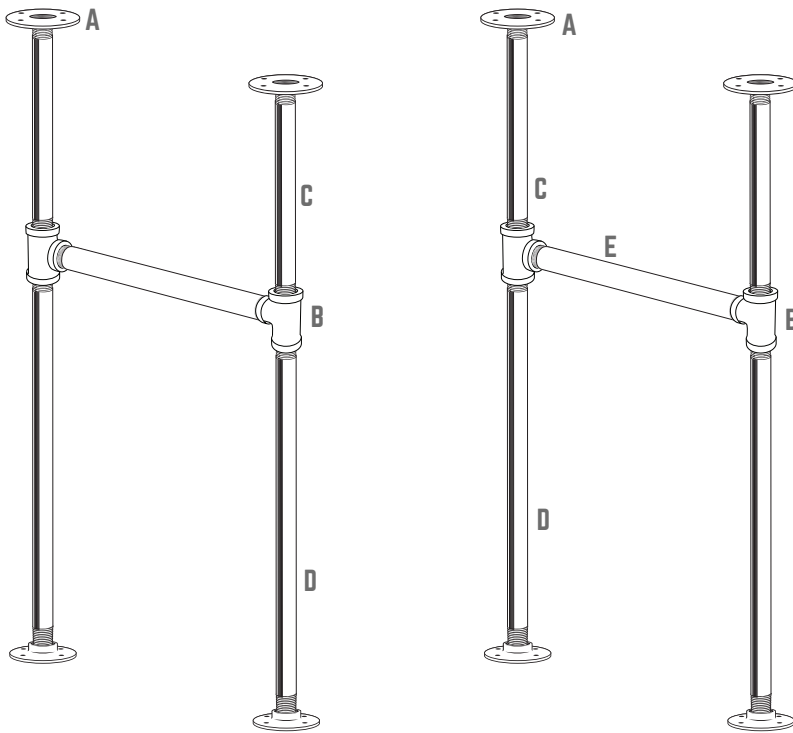

## HOW TO PREVENT PIPE CORROSION

PIPE DECOR industrial-grade black pipes and fittings are coated with a rust-preventive oil during manufacturing. For best results, **SEAL THE PIPES TO AVOID ANY RUSTING** after cleaning the kit.

### CLEAN AND SEAL INSTRUCTIONS:

- CLEAN:** Recommended supplies: regular degreasing dish soap, washcloths, gloves (optional)
1. Wash your pipes and fittings with warm water and dish soap until the oil is completely removed.
  2. Wipe the pipes with a dry washcloth and wait until the pipes are completely dry.

**IMPORTANT: THE PIPES MUST BE COMPLETELY DRY BEFORE YOU START THE SEALING PROCESS.**

**SEAL:** **IF USING POLYURETHANE SPRAY:** Spray each dry pipe and fitting with a polyurethane matte or satin finishing spray and let it dry before assembling the kit.

**IF USING FINISHING WAX:** Coat each dry pipe with a finishing wax. Wait for 20 minutes, then polish the pipe with a dry washcloth by wiping them down. Faster wiping will result in a shinier finish.

# PIPE DECOR<sup>®</sup> 3/4" H-LEG OUTSIDE TABLE KIT

\*Repeat step 1 to step 3 other other leg.

**STEP 1:**

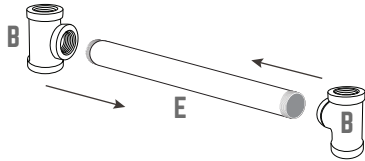

**STEP 2:**

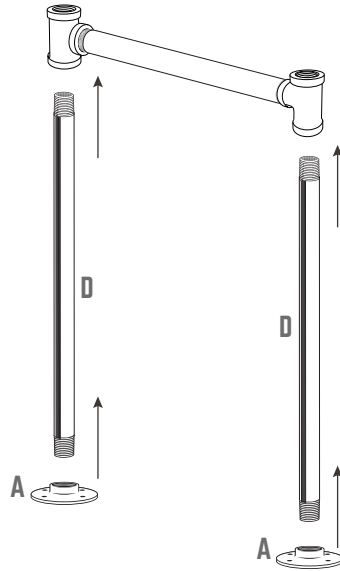

**STEP 3:**

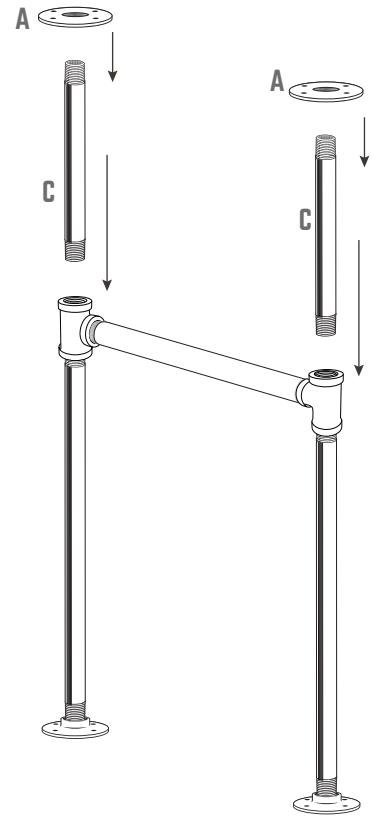

**STEP 4:**

Screw into table top (not provided) with the provided screws.

